

# Investigation of Silver Biocide as a Disinfection Technology for Spacecraft – An Early Literature Review

Wenyan Li<sup>1</sup> and Luz M. Calle<sup>2</sup>  
NASA, Kennedy Space Center, FL, 32899

and

Anthony J. Hanford<sup>3</sup>, Imelda Stambaugh<sup>4</sup> and Michael R. Callahan<sup>5</sup>  
NASA Johnson Space Center, Houston, TX, 77058

**An ideal spacecraft water disinfection system should prevent or control microbial growth, inhibit or prevent biofilm formation, and prevent microbial-induced corrosion. In addition, the selected biocide system should be chemically compatible with materials used in the water storage and distribution system, have minimal maintenance requirements, especially for long-duration missions, and should be safe for crew consumption at levels appropriate for biocidal control. Silver ion is a proven broad spectrum biocide. There has been an increased interest in the biocidal function of silver, both due to its potential to control biocide resistant species and due to advances in silver and nanosilver biocide technologies. NASA is considering silver as the future biocide for exploration over the iodine biocide system. In order to select and design a successful silver biocide delivery system to meet NASA's requirements, it is essential to understand the advantages and disadvantages of moving to a silver disinfection system. To enhance the knowledge base for the application of silver biocides in spacecraft water systems, this paper provides a first compilation of review data related to: (1) Silver as a biocide technology, (2) Options and concepts for silver biocide delivery, and (3) Silver biocide compatibility studies for spacecraft systems.**

## Nomenclature

<i>AgNPs</i>	= silver nanoparticles
<i>ATV</i>	= Automated Transfer Vehicle
<i>DNA</i>	= deoxyribonucleic acid
<i>EDTA</i>	= ethylenediaminetetraacetic acid
<i>FEP</i>	= perfluoroelastomer
<i>ISS</i>	= International Space Station
<i>LBC</i>	= low biocide concentration
<i>PWD</i>	= potable water dispenser
<i>RNA</i>	= ribonucleic acid
<i>ROS</i>	= reactive oxygen species
<i>TEM</i>	= transmission electron microscopy
<i>UV</i>	= ultraviolet
<i>WHO</i>	= World Health Organization

---

<sup>1</sup> Research Scientist, URS Federal Services, Inc., Mail Code: LASSO-001

<sup>2</sup> Senior Research Scientist, Science and Technology Programs Division, Mail Code: UB-R2

<sup>3</sup> HX5, LLC, JETS Contract, 2224 Bay Area Blvd., Mailstop JE-5EA, Houston, Texas, 77058.

<sup>4</sup> NASA, Analyst Lead, Crew and Thermal Systems Division, 2101 NASA Parkway/EC2, Houston, Texas, 77058.

<sup>5</sup> NASA, Water Technology Lead, Crew and Thermal Systems Division, 2101 NASA Parkway/EC3, Houston, Texas, 77058.

## I. Introduction

SILVER is a proven broad spectrum biocide. There has been an increased interest in the biocidal function of silver, due to the recent advance in silver and nanosilver biocide technologies, and their potential to address antimicrobial resistance in clinically relevant organisms. NASA is interested in adopting silver biocide as replacement for the iodine water treatment system for long duration exploration missions. Although iodine treated water has been used successfully with the International Space Station (ISS), its use requires that the iodine be removed before being consumed by astronauts due to its adverse effects on the thyroid. An ideal biocide or water disinfectant should have no adverse effect on humans, prevent microbial growth, biofilm formation, and microbial-induced corrosion in the water storage and distribution systems while minimizing maintenance requirements. It is essential to understand the biocidal mechanism of silver ions, as well as the different advantages and disadvantages of the various potential delivery systems in order to design or select biocide delivery systems to meet these requirements. This paper presents a brief review of silver biocides and of various silver biocide delivery systems.

## II. Overview of Water Treatment Technologies

### A. Types of Contaminations

Three types of pathogenic microorganisms are the main concerns for drinking water: protozoa, bacteria, and viruses.<sup>1</sup> Their characteristics are shown in Table 1. Besides these three germs, there are a large number of additional pathogens known. However, according to the World Health Organization (WHO), their pathogenic action is only slight or they are primarily absorbed along with food.

**Table 1. Pathogenic microorganisms in water.**

Type (Examples)	Characteristics
<b>Protozoa</b> ( <i>Amoebae</i> , <i>Giardia lamblia</i> , <i>Cryptosporidia</i> )	<ul style="list-style-type: none"><li>• Animal single-cell organisms, 1-15 microns in size.</li><li>• Contaminate water through animal and human feces.</li><li>• Form cysts, which lead to acute gastrointestinal diseases in human.</li><li>• A single cell can cause an infection.</li></ul>
<b>Bacteria</b> ( <i>E. coli</i> , <i>Salmonella</i> , <i>Vibrio cholerae</i> )	<ul style="list-style-type: none"><li>• Single-cell organism, 0.5 – 5 microns in size.</li><li>• Contaminate water through animal and human feces.</li><li>• Propagate quickly in warm environments and, particularly in water, become dangerous when mixed together with human and animal feces in the drinking water.</li></ul>
<b>Viruses</b> (Hepatitis A, Norwalk virus, Rota virus, Polio virus)	<ul style="list-style-type: none"><li>• An infective agent, 0.02-0.2 microns in size.</li><li>• Can only propagate in living cells since they do not possess their own metabolism.</li><li>• Contaminate water through animal and human feces near populated areas where wastewater can get into drinking water.</li></ul>

### B. Types of Treatments

Different water treatment technologies are available for various types of water sources, the quality, and flow rate of the water to be treated. Factors to be considered are: Is the water cloudy or clear? Is the water loaded with chemicals? How much drinking water is needed and how rapidly? Do viruses, as well as bacteria and protozoa, have to be eliminated?<sup>2</sup> Among all the available water treatment technologies, adsorption (active carbon) and ion exchange are not effective for disinfection, but reduce chemical contaminants and improve the taste of the water. Various filtration techniques remove germs and suspended solids that are bigger than their pore size, so it is challenging to remove viruses from water due to their extremely small sizes. Only ultraviolet (UV) devices and chemical biocides kill germs of all sizes, but they do not improve the taste or appearance of the drinking water. Silver (Ag) is one of the trusted chemical biocides for water treatment.

## III. Biocidal Activity of Silver Ion and Nanosilver

Though the antibacterial function of silver compounds is well known, their biocidal mechanisms are not completely understood. This is likely due to the versatility of the silver biocides that compounds the already complex nature of the interaction between biological organisms and their environment. Several overviews on silver

biocides have provided great insight on the subject, including the Case Study by the Environmental Protection Agency<sup>3</sup> and a literature review published by WHO.<sup>4</sup>

### A. Silver and its Physicochemical Properties

In nature, silver metal ( $\text{Ag}^0$ ) and silver ion ( $\text{Ag}^+$ ) are the most common states of silver. The most abundant silver compounds in the environment are silver sulfide ( $\text{Ag}_2\text{S}$ , Argentite), silver nitrate ( $\text{AgNO}_3$ ), and silver chloride ( $\text{AgCl}$ , Cerargyrite). Earth's crust contains 0.08 ppm of silver, while urban soil contains about 0.3 ppm silver.<sup>5</sup> Besides composition, there are other important physicochemical properties that influence the biocidal properties of silver, such as solubility, size (and dispersibility), morphology (shape and crystal structure), surface area, and electrical, magnetic, and optical properties.

Solubility determines the dissolution of the silver compounds and release of silver ions (as shown in Table 2). It is an important factor that influences the bioavailability of silver and its biocidal efficiency. Solubility in water also reflects the strength of the covalent bonds between silver and other elements, which in turn determine its biocidal efficiency. For instance, the electronegativity values (by Pauling's scale) of Ag, sulfur (S), chlorine (Cl), oxygen (O), and fluorine (F) are 1.93, 2.58, 3.16, 3.44, and 3.98, respectively. Based on the difference in electronegativity, the Ag-S bond is less polar than the Ag-Cl bond, and very stable in water ( $K_{sp}$  of  $\text{Ag}_2\text{S}$  is about  $10^{-49}$ , while the  $K_{sp}$  of  $\text{AgCl}$  is about  $10^{-10}$ , and that of  $\text{AgOH}$  is about  $10^{-8}$ ); on the other hand,  $\text{AgF}$  is highly soluble in water, with a solubility of 182 g/100 mL at 15.5°C.<sup>6</sup> This is consistent with one of the main silver biocidal mechanisms: through the strong interaction of silver with the thiol ( $-\text{SH}$ ) group of the biological systems.

**Table 2. Solubility product constants for various silver compounds.<sup>7,8</sup>**

Silver compound	Formula	Solubility product constant ( $K_{sp}$ ) at 25°C
Silver	Ag	Insoluble
Silver sulfide ( $\alpha$ -form)	$\text{Ag}_2\text{S}$	$6.69 \times 10^{-50}$
Silver sulfide ( $\beta$ -form)	$\text{Ag}_2\text{S}$	$1.09 \times 10^{-49}$
Silver arsenate	$\text{Ag}_3\text{AsO}_4$	$1.03 \times 10^{-22}$
Silver iodide	AgI	$8.51 \times 10^{-17}$
Silver phosphate	$\text{Ag}_3\text{PO}_4$	$8.89 \times 10^{-17}$
Silver bromide	AgBr	$5.35 \times 10^{-13}$
Silver chromate	$\text{Ag}_2\text{CrO}_4$	$1.12 \times 10^{-12}$
Silver oxalate	$\text{Ag}_2\text{C}_2\text{O}_4$	$5.40 \times 10^{-12}$
Silver carbonate	$\text{Ag}_2\text{CO}_3$	$8.46 \times 10^{-12}$
Silver chloride	AgCl	$1.77 \times 10^{-10}$
Silver sulfate	$\text{Ag}_2\text{SO}_4$	$1.20 \times 10^{-5}$
Silver bromate	$\text{AgBrO}_3$	$5.34 \times 10^{-5}$
Silver nitrate	$\text{AgNO}_3$	Highly soluble
Silver fluoride	AgF	Highly soluble

### B. Bioavailability

Exposure to a biocide requires contact between the biocide and the surface of an organism via the environmental media. For internal exposure to occur, the biocide must penetrate the organism's cellular walls, membranes, or other barriers. Bioavailability of silver is likely to be a function of its form, the characteristics of the environmental exposure medium, and those of the organism.

Different attributes of an organism can influence bioavailability of silver biocides. The type of organism, its structure, and its physiology are key determinants of its biocide uptake mechanism. Whether the organism is prokaryote (a microscopic single-celled organism without a distinct nucleus or other specialized organelles) or eukaryote (an organism consisting of a cell or cells with a distinct nucleus), its cell size, cell wall or membrane construction, type of circulatory system, respiratory physiology, and other major aspects of its physiology can play important roles in the biocide uptake process.

It should be mentioned that if silver nanoparticles ( $\text{AgNPs}$ ) adhere to an organism's external surface and release silver ions, the concentration of silver ions in the immediate vicinity of the organism might be higher than that in the surrounding medium; this "local" silver concentration is more relevant than the overall silver concentration, but it is challenging to measure.

For water treatment applications, the properties of water, including trace inorganic and organic matter content, will play important roles in changing the bioavailability of silver. This likely happens through aggregation of AgNPs and complexing of nanosilver or silver ions with organic or inorganic materials to form larger particles or insoluble precipitates.

Many ligands exist for silver ions, including inorganic ligands (chloride, bicarbonate, thiosulfate), simple organic ligands (amino acids and ethylenediaminetetraacetic acid, EDTA), and complex polydispersed organic ligands (humic and fulvic acids). Silver binds very strongly with sulfide ( $S^{2-}$ ) and only forms relatively insoluble AgCl with the chloride anion ( $Cl^-$ ). The abundance of  $Cl^-$  favors the formation of soluble silver chloro complexes.

Nanosilver bioavailability is likely related to that of silver ions, but studies are often carried out for its toxicity, rather than specifically for its bioavailability. From the results of toxicity tests, the release rate of silver ions generally decreases with increasing particle size, due to the surface-volume relationship. Release of silver ions from nanosilver is also enhanced in oxidative conditions. The bioavailability and toxicity of AgNPs for bacterial and mammalian cells increases with increasing concentration of hydrogen peroxide ( $H_2O_2$ ). Among  $S^{2-}$ , sulfate ( $SO_4^{2-}$ ),  $Cl^-$ , phosphate ( $PO_4^{3-}$ ), and EDTA,  $S^{2-}$  is the most effective ligand in reducing AgNP toxicity to nitrifying bacteria.<sup>9</sup> In seawater, the high ionic strength and high  $Cl^-$  content can lead to the formation of nanosilver clusters, and/or the formation of soluble silver chloro complexes; either process can dominate depending on the water chemistry, presence of organic matter, and AgNP surface treatment.<sup>10</sup> The addition of natural organic compounds or thiols enhances the nanosilver presence in solution.

### C. Biocidal Activity of Silver Ion

Silver ions are highly toxic to all microorganisms, probably due to poisoning of the membrane respiratory electron transport chains and components of DNA replication.<sup>11</sup>  $Ag^+$  affects the function of membrane-bound enzymes, such as those in the respiratory chain.<sup>12</sup> It has been shown that after  $Ag^+$  treatment, DNA loses its replication ability and proteins become inactivated.<sup>13</sup> The antimicrobial action of silver ion is closely related with its interaction with the thiol group in enzymes and proteins. Recent work also showed that  $Ag^+$  treatment promotes reactive oxygen species (ROS) production, which results in an enhanced antibacterial effect, as ROS are highly toxic oxidants that cause damage to proteins, DNA, RNA, and lipids.<sup>14</sup> A summary of the antimicrobial effects of silver is illustrated in Figure 1. Detailed discussion on the mechanism of the antimicrobial actions of the silver ion can be found in references 15 and 16.

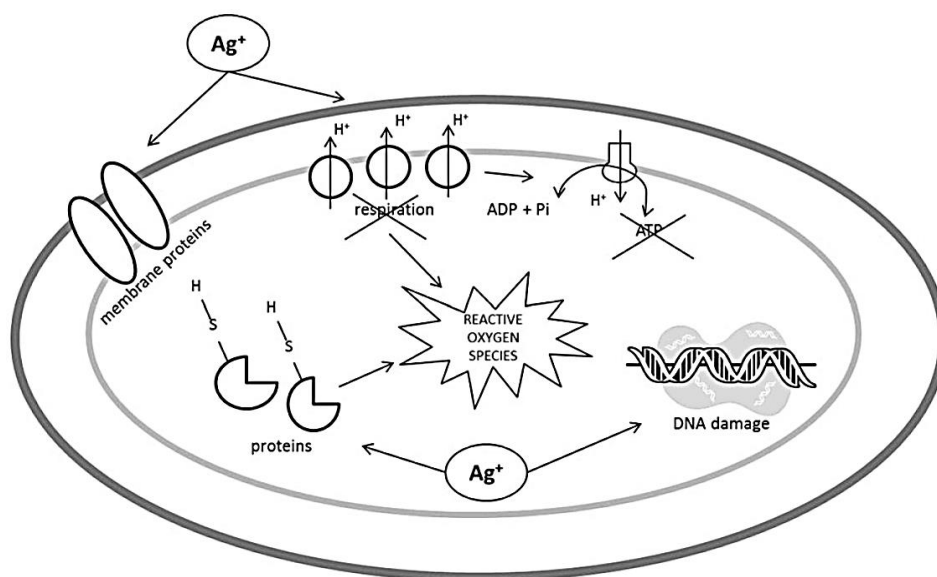

**Figure 1. Antimicrobial effects of  $Ag^+$ : Interaction with membrane proteins, blocking respiration and electron transfer; inside the cell,  $Ag^+$  ions interact with DNA, proteins, and induce ROS production.** Reprinted by permission from: Nature/Springer/Palgrave.<sup>13</sup>

#### **D. Uptake and Biocidal Activity of Nanosilver Biocide**

Bacteria readily take up nanosilver, which is consistent with its well-known antibacterial properties. It has been shown that only oxidized AgNPs function as biocide (reduced nanosilver is easily oxidized).<sup>17</sup> The antimicrobial effect of nanosilver is likely due to a combination of nanosilver, which can anchor to and penetrate the cell wall, and the silver ions that are chemisorbed on the surface.

The membrane structures of bacteria are classified into two groups: gram-positive and gram-negative. The cell wall of gram-positive bacteria includes a 30-nm-thick peptidoglycan layer, while the cell wall of gram-negative bacteria includes only a thin, 2- to 3-nm layer of peptidoglycan. The gram-negative cell wall also contains an additional outer membrane composed of phospholipids and lipopolysaccharides facing the external environment. The largest pores in the outer membrane of gram-negative bacteria secrete bacterial proteins out of the cell and can measure almost 10 nm in diameter. These pores are likely to “open” only as needed for protein transport across the membrane. Fixed porins, which allow diffusion of smaller molecules in both directions across the outer cell membrane, are smaller, with effective diameters for solutes of 1–2 nm. Despite the small pore sizes of both membranes, nanoparticles up to 80 nm can enter some bacterial cells. Furthermore, bacteria can then extrude these nanoparticles through the living cell membranes via an extrusion pump, consisting of two outer membrane proteins and one inner membrane protein, even though the pores associated with this extrusion pump are more than 50 times smaller than the nanoparticles they extrude. Cellular invasion and extrusion mechanisms of these larger nanoparticles are not well understood.

Nanosilver can anchor and penetrate the cell wall of gram-negative bacteria. It has been suggested that this could increase its permeability and result in uncontrolled transport of materials; it has also been proposed that the antibacterial mechanism of nanosilver is the formation of free radicals that damage the membrane; still, others proposed that a synergistic toxic effect with nanosilver adsorbed to the bacterial cell wall surface, silver ions can move into the cells and produce ROS.

Experimental results have provided strong support to the anchoring function of nanosilver. Pal and his coworkers evaluated the toxicity of nanosilver with various different shapes along with AgNO<sub>3</sub>. It was found that truncated triangular nanoparticles (with [111] facet) exhibited the strongest antibacterial activity. Transmission electron microscopy (TEM) showed that many triangular nanoparticles adhered to the cell surface.<sup>18</sup> Though not a conclusive study, the mechanism of AgNPs as a disinfectant has been summarized in some references.<sup>19</sup>

#### **E. Human Exposure and Toxicity**

Due to the long history of silver usage as a biocide and lack of known toxic effects, silver is generally considered safe to humans at the effective biocidal level. However, the growing use of nanosilver and silver colloid products has raised some concern recently. Some highlights on human exposure are summarized below and more detailed information can be found in references 3, 4, and 20.

The degree to which exposure leads to absorption, distribution, metabolism, or excretion (clearance) in humans depends on particle properties and the route of exposure. Current data suggest that silver from nanosilver can be taken up via inhalation, oral exposure pathways, and subsequently crosses biological barriers to accumulate in tissues, including lungs, liver, kidneys, stomach, brain, and blood. In animal studies, elevated silver concentrations in lung and blood were found following inhalation. The highest silver concentration was found in the lungs, suggesting that translocation to other tissues is not extensive. Whether conventional silver can cross the blood-brain barrier in humans is controversial. No evidence to date indicates that AgNPs, even those as small as 1–2 nm, can penetrate the blood-brain barrier in mammals.

Treatment of burn wounds in humans has resulted in kidney, liver, and skin accumulation of silver. Silver absorption across healthy human skin was demonstrated when exposed to suspensions of nanosilver, though it is not clear if this is through transport of silver nanoparticles or ions released. Damaged skin showed higher rate of silver absorption. Only in one case, neurological effects were observed, suggesting that silver might have entered the brain, but the case is complicated due to the preexisting kidney condition of the patient. Ingestion exposures to nanosilver appear to result in lower relative absorption and subsequent dose compared to other exposure pathways. Conventional silver has been demonstrated to cross the intestinal barrier following ingestion exposure. The limited data for nanosilver suggests that particle characteristics, including surface modification, affect whether nanosilver is absorbed or excreted following ingestion.

#### **F. Resistance to Silver Biocide**

There are not many studies on the resistance to silver systems and most studies on silver biocide were not long enough to create resistance. However, bacteria are the most adaptive organisms known and have been shown to

develop resistance to the spectrum of bactericidal agents, including antibiotics and heavy metals. Many metal resistance mechanisms in bacteria are recognized.<sup>21</sup> Bacteria generate cell surface proteins that bind heavy metals, producing a barrier to metals entering the cell. Other metal detoxification proteins are produced in the cytoplasm of bacteria and other organisms. These proteins are simple products of single genes that can easily be amplified to develop increased metal resistance. Bacteria also can exclude silver that has reached the cell's interior through efflux pumps, which bind to the silver ions and transport them to the cell surface where they are ejected. Plasmids that encode resistance for metals, including silver, have been isolated from bacteria.<sup>22</sup> Development of resistant strains can be expected when the exposure continues for several years, such as in the extended study of the effects of silver/copper disinfection on *Legionella* in a German hospital water system.<sup>23</sup> A detailed review on the bacterial resistance to silver can be found in references 24 and 25. The possible resistance mechanisms were proposed, but experimental work failed to produce strong support for them. A thorough understanding of silver resistance is yet to be achieved.

To cope with silver resistance, the following recommendations have been made: First, look for a different disinfectant that will complement the silver system and that can be alternated with it on a regular basis. Secondly, considering that any population of bacteria would be expected to develop resistance, after a period of exposure, it may be best to periodically eliminate the entire bacterial population. Where possible, water systems should be drained, cleaned and shocked with chlorine, ozone, or another aggressive disinfectant. As it is difficult to completely sterilize the system, a regular drain and shock program is not a replacement for biocide alternation, and both of these approaches should be utilized.<sup>26</sup>

#### **IV. Silver Dosing Systems: State-of-the-Art**

To use silver biocide in a drinking water system, the silver ion supplied to the water system should be sufficient to obtain complete sterilization, without exceeding the toxic concentration limit, and the residual silver should be enough to serve as a reserve after sterilization, to prevent further contamination. In other words, a dosing/delivery system is needed to design an effective water treatment process using silver as a biocide.

Considering the long history of silver ion as a biocide and the renewed interest in silver, there are surprisingly few publications on silver ion delivery methods. However, a patent search proved to be fruitful. The following section provides a short review on silver delivering/dosing systems.

##### **A. Silver Coated Filtrating Media**

Metallic silver was one of the first silver biocides considered for water treatment. To increase the contact surface, silver is used to coat filtrating media, such as sand and activated carbon.

###### *1. Silver Coated Sand*

In US patent 1642089 (1927), Schreier described a method to coat sand particles with silver, and use it as a filtration medium to sterilize liquid for human consumption.<sup>27</sup> A formula for preparation of the silver coating is the following: 7 parts by weight of 0.1 normal solution of silver nitrate are diluted with 3 parts of distilled water. 0.3 parts of a 40% formaldehyde solution is added into the mixture. Then 4.7 parts of 0.1 normal ammonia solution are added and mixed under agitation. This solution is mixed with washed and cleaned quartz sand while stirring. After a short time, the liquid and the grains darken. The amount of sand or its grain size are not specified in the patent. The silver coated sand is used as filtration media to sterilize liquids for human consumption. No example is given in the patent.

In US patent 1,988,246 (1935), one of the early patents on the "oligodynamic action" (ability to exert a bactericidal effect at minute concentration) of silver biocide, Krause introduced a two-step process for water sterilization.<sup>28</sup> First, the contaminated water (with *B. Coli*, half million communities per cubic cm) was filtered through silver coated quartz sand; the sand (300 grams) was coated with 30 grams of silver by wetting it with silver nitrate solution and then heating in a muffle furnace at 400°C. The quartz sand was placed in a suction-filter and 5 liters of contaminated water were passed through per minute. The filtration did not completely filter out the bacteria and still contained 15,000 bacilli per cubic cm. Second, the water was left to stand in a container and, after 10 hours, complete sterility was ensured. Though not specified, the sterilization was likely achieved by the action of silver ion released from the silver coated sand. This setup was used to process 1500 liters of water and achieved total sterilization, as shown in the examples.

###### *2. Activated Carbon with Impregnated Silver*

Activated carbon is one of the most used filtration materials. It can be impregnated with an aqueous  $\text{AgNO}_3$  solution. After the water is evaporated and the product is heated to a higher temperature, the  $\text{AgNO}_3$  will be

converted to metallic silver. This procedure often results in an impregnation that is not very uniform, due to the premature reduction of  $\text{AgNO}_3$  by carbon and the formation of large silver crystals.

In US patent 3,294,572 (1966), Piccione *et al.* disclosed a method to prepare a more uniform silver impregnated carbon.<sup>29</sup> First, the activated carbon was soaked in a strongly acidic solution of  $\text{AgNO}_3$ , then the slurry was heated at 70 to 80°C to evaporate water until the carbon was just wet; then, it was transferred to a flask and heated at higher temperature (up to 500°C) in a nitrogen atmosphere to form metallic silver.

Silver impregnated active carbon, when properly prepared, has the potential for widespread use in sterilization and purification of liquid; yet, due to organic substances accumulated on the surface of the material, these filter materials can be rapidly spent, and their applications are limited. US patent 4,045,553 (1977) disclosed a process to restore the sterilization and purification properties of these materials through periodical treatment with steam.<sup>30</sup> The surface fouling of activated carbon filtering materials is similar to heterogeneous catalyst deactivation, though possibly in a less complicated manner.<sup>31</sup> It is not surprising that similar techniques are used for the regeneration of these materials.

## **B. Silver Compounds with Various Solubilities**

The use of solutions of silver compounds, as a source of silver ions, has been suggested. In some cases, the compounds are more toxic than silver ion itself; but mostly, it is difficult to dissolve at a rate sufficient to reach, but not exceed, the required silver biocide concentration. Nevertheless, different silver compounds are incorporated into water filtration systems.

### *1. Silver Chloride, Silver Oxide, and Silver Sulphocyanate*

In US patent 1,473,331 (1923),<sup>32</sup> H. Bechhold disclosed filters and filtering systems to prevent or retard infection by impregnating filtering masses, such as layers of sand or coke on a large scale, with noble metals or their compounds that are insoluble or of low solubility. The suitable filtering materials include diatomaceous earth, cellulose, and clay, among other suitable materials. The filtering systems, having beds or layers of sand, gravel, coke or the like, were utilized for filtration on a large scale. They retained micro-organisms for a certain time, yet the microorganisms can grow through the pores of the filters, so the filtered liquid would become infected in a few days. To prevent this process, disinfectants were used, including silver,  $\text{AgCl}$ , silver oxide, and silver sulphocyanate. Excellent results were obtained when activators, such as gold and platinum, were also used. For instance, a diatomaceous earth filter was impregnated with silver (2%) and platinum (a small fraction of the silver). Water infected with *B. Coli* was passed through this filter and also through a similar one untreated. Whereas the latter yielded a filtrate which only remained sterile for two days, the treated filter supplied sterile water for a long time. A similar effect was obtained when  $\text{AgCl}$  was used as the disinfectant and gold as the activator.

For filtering systems with filtering masses, such as layers of sand or coke, the individual particles of these materials, impregnated with the disinfectants could be used. To achieve effective filtration and disinfection, the impregnation method is important. The impregnation process should ensure the uniform distribution and limit the leaching of disinfectants within the filtering mass. For instance, a filter was first treated with vaporized ammonium chloride, which precipitated uniformly in the pores of the filter. Then, the filter was treated in the vacuum with a  $\text{AgNO}_3$  solution to allow  $\text{AgNO}_3$  to penetrate into all pores.  $\text{AgCl}$  was precipitated and fixed into the filtering mass in uniform distribution. Another method was to soak the filter with a salt of low osmotic pressure, and then bring it into a solution of higher osmotic pressure. The two will react without forming a semi-permeable membrane that leads to uniform impregnation of disinfectant throughout the filter. For instance, a filter is first soaked with a diluted solution of  $\text{AgNO}_3$  and brought into a solution of sodium chloride (with higher osmotic pressure). The filter will be uniformly impregnated with  $\text{AgCl}$ .

### *2. Silver Chloride, Silver Sulfide*

In US patent 2,595,290 (1952),<sup>33</sup> D. H. Quinn discloses the purification of water by means of a two-step processes: the first step is mechanical filtration, preferably using a ceramic filter of fine porosity, such as that in patent US 2,566,371;<sup>34</sup> in the second step, which combines adsorptive and chemical treatment, the water is passed through a three component system: a granular mass comprising an admixture of adsorptive granules, granules of an ion exchange synthetic resin, and granules coated with a bactericide of very low water solubility.

In the first step, mechanical filtration is used to remove solid particles and bacteria from the water. In the second step, the combined adsorption and chemical treatment, each one of the three components provides a complimentary function. The adsorptive granules act by capillary action to remove impurities such as chlorine, bacterial toxins, and others that impart objectionable odors and taste. For this function, both activated carbon and silica gel can be used, with activated carbon as the preferred material. The ion exchange granules act chemically on similar impurities. The combination provides a more effective action. For example, it was found that bacterial toxins, such as botulinum,

staphylococcus, and diphtheria were effectively removed from water by such treatment. Any known ion exchange synthetic resin, such as those under the trade names Amberlite™ and Duolite™, can be used. The last component, the slightly soluble bactericide, with which certain of the granules are coated, has the function of rendering sterile any water that remains in the apparatus for a longer period. It might be possible for bacteria deposited on the mechanical filter to produce spores that penetrate the filter. The slight soluble bactericide is released into the water, at a rate adequate to kill any vagrant bacteria, but low enough to be safe for human consumption. The preferred bactericide is AgCl, coated to only a few of the granules, because the coated granules have little adsorptive capacity, and serve only as bactericide carries. Carbon granules or siliceous material, such as fine sand, can be used as carrier materials. The loading of the bactericide should be sufficient for a long lasting effect. Bactericide can also be used in granular form, with suitable mechanical properties, rather than as a surface coating on carrier granules. One component being a carrier, coated with either AgCl or Ag<sub>2</sub>S. However, the use of rather soluble AgCl or silver oxide (Ag<sub>2</sub>O) for water sterilization still requires careful control of the amount of the compound dissolved to maintain the silver ion concentration below the toxic limit. Moreover, silver thiocyanate is extremely toxic due to the thiocyanate ion. Thus, these processes also require a supplemental step for removal of excess silver ion after sterilization has been effected. On the other hand, Ag<sub>2</sub>S is extremely insoluble and a saturated Ag<sub>2</sub>S solution will not contain enough silver ion to obtain complete sterilization.

### 3. Silver Bromide

Pall *et al.*,<sup>35</sup> in US patent 3,257,315 (1966), claims to supply silver ions to water, intended for human consumption, in an amount sufficient to obtain complete sterilization without exceeding the toxic concentration limit and with enough silver supplied to the water to serve as a reserve after sterilization, to prevent further contamination. The inventors claim that both concentration control and subsequent contamination elimination can be achieved in one step. The silver source used is AgBr, in a “surface condition,” and the contact time should be sufficient to dissolve enough AgBr to ensure a silver ion concentration of 10 to 50 ppb, preferably at least 20 ppb. To achieve the large surface area of AgBr, it can be mixed with a filter media with large surface area, such as sand, charcoal, diatomaceous earth, among other examples, to form a filtration bed or column, through which water can be flowed. Or AgBr can be made into tablets, with suitable extender and binder; these tablets can be placed in the water, inside a water permeable container preventing solid particles of AgBr from escaping.

In the example of this patent, AgBr was coated on sand by mixing at 550°C with stirring to ensure uniform coating. The coated sand was placed in a tower as shown in Figure 2. Water is pumped into the bottom of tank (6), and emerges with 10 to 50 ppb silver at outlet (7), passing to the bottom of storage tank (10) and emerging finally from the system in purified and sterilized condition. The water is retained for sufficient time to allow sufficient silver ion to dissolve in tank (6) and to kill all bacteria in tank (10). For example, contaminated water containing *E. coli* was passed through the bed, slowing at room temperature, to ensure a contact time of 20 minutes and was passed through a retention tank with a retention time of 2 hours. The water emerging from the bed was tested, and found to be completely sterile. The concentration of silver in the water emerging from the retention tank was 17 ppb.

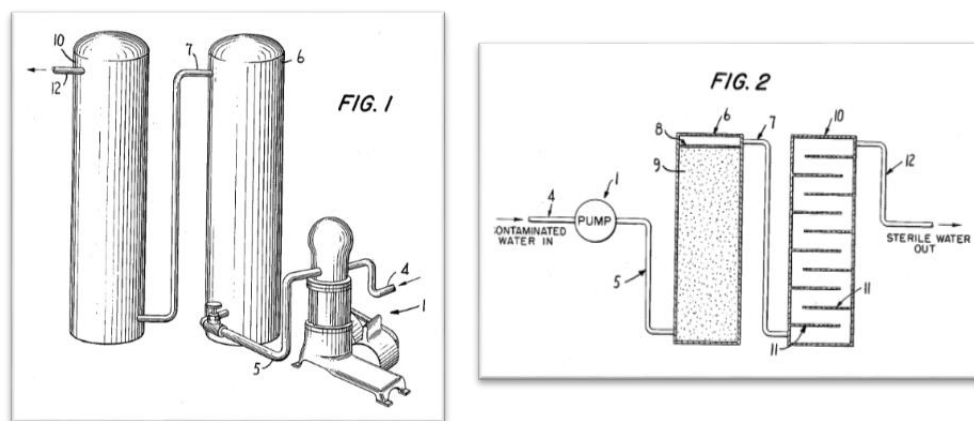

**Figure 2. Illustration of a combination pump and sterilization unit (left) and its cross-sectional view of the sterilization unit from US patent 3,257,315.<sup>32</sup>**



### C. Silver-Containing Ion Exchanger

#### 1. Anion Exchange Resin

G. P. Ham in US patent 2,434,190 (1951)<sup>36</sup> discloses the preparation of a “silvered” anion exchange resin. An anion exchange resin, the sodium form, may be treated with a  $\text{AgNO}_3$  solution to load the resin with silver ions. The resin is then treated with a reducing agent such as potassium metabisulfite to form metallic silver. The incorporation of the “silvered” anion exchange resin enhances the resistance to bacteria of elastomers, such as those used in vehicle tires, rubber insulation, and water hoses.

#### 2. Cation Exchange Resin

W. Juda, in US Patent 2,692,855 (1954),<sup>37</sup> discloses a cation exchange resin in a silver ion form for disinfection of water. For example, a cation exchange resin in the hydrogen form may be treated with a silver salt solution to exchange silver ions for hydrogen ions, thereby producing a resin for disinfecting water. However, it is necessary to minimize release of silver ion to a safe level by passing water first through a cation exchange resin in the hydrogen form to demineralize the water.

#### 3. Chelating Resin

G. L. Marchin and J. L. Lambert,<sup>38</sup> in US patent 5,366,636 (1994), disclosed a method that uses a chelating resin containing an iminodiacetate acid group at the metal chelating sites (Trade name Chelex by Bio-Rad<sup>TM</sup>), in order to minimize the release of silver ions to a safe level. The resin composition contains less than 1 silver ion per two iminodiacetate groups. The silver ions are retained within the resin bead while effectively killing microorganisms and/or removing iodide from the water. As a comparison, silver sulfonic acid resin and silver-zeolites are also prepared. Under the testing conditions described in the patent, after passing the Ag-Chelex resin, the free silver ion concentrations of eluates is  $0.9 \times 10^{-5}$  M using distilled water, and less than  $1 \times 10^{-6}$  M using tap water containing  $1 \times 10^{-5}$  M potassium iodide (KI), which correspond to 900 and 100 ppb silver ion, respectively. The Ag-sulfonic acid resin and Ag-zeolite releases 100 to 10,000 times more silver ion under the same test conditions.

#### 4. Inorganic Ion Exchanger-Based Biocidal Composite

Like ion exchange resins, silver containing inorganic ion exchangers have also been considered for biocidal applications. For example, zeolite particles of various sizes can be treated in a solution with silver ion at a pH that does not destroy the crystal structure of the zeolite.<sup>39,40</sup> Unlike polymer resins, inorganic ion exchangers lack structural integrity for long-term stable release. In addition to silver ion release, the dusting and loss of zeolite powder also result in a large variations in the silver elution amount and the silver concentration is not stable.

US Patent 4,911,898 discloses zeolite particles, incorporated into polymer articles made of Polyester or Nylon 6,<sup>41</sup> to improve the mechanical properties of silver. In the same patent, it is also mentioned that the zeolite particles should retain the bactericidal metal ion in an amount less than an ion-exchange saturation capacity of the zeolite. Otherwise, the bactericidal effect of the polymer particle is very poor. This is due to surface deposition of the metal in a form other than silver ion, such as  $\text{Ag}_2\text{O}$ , which is detrimental to the bactericidal function of the silver zeolite particle. To avoid this, metal ions may be supplied from a dilute metal ion solution, through repeated procedures.

Another inorganic ion exchanger investigated is zirconium phosphate, a well-known inorganic ion exchanger.<sup>42</sup> Silver-modified zirconium phosphate (Ag-ZrP) has been studied as an antimicrobial agent,<sup>43</sup> as well as a photocatalyst.<sup>44</sup> In international patent application WO2011114976,<sup>45</sup> the inventors disclose a polyamide resin composition containing Ag-ZrP to achieve continuous long term silver ion release, at a concentration that is effective for antimicrobial treatment and safe for human consumption. This composition contains a Ag-ZrP with a representative formula:  $\text{Ag}_a\text{M}_b\text{Zr}_c\text{Hf}_d(\text{PO}_4)_3 \cdot n\text{H}_2\text{O}$ , where M is an alkali metal ion, an alkaline earth metal ion, ammonium ion, at least one kind of ions selected from hydrogen ions, and the group consisting of oxonium ions; a, b, and c are positive and their values are restricted by the total charge being neutral. The 3-D crystalline zirconium phosphate is the preferred structure for this application, due to their superior thermal and chemical resistance. Silver-substituted hexagonal zirconium phosphate, obtained by substitution, not only exhibits excellent antibacterial properties, durability, and ion selectivity, but also exhibits superior properties during resin processing. A detailed synthesis process is described in the patent application. Several silver-containing antibacterial agents were synthesized, blended with various resins, and made into plates and pellets. Various samples have been tested for their silver release properties. Some compositions provided sustained release up to 90 days with daily water replacement.

### D. Electrolytic Generators and Electrochemical Method

Electrolytic generators are usually composed of a negatively charged cathode and a positively charged anode made of the metal to be ionized. The electrodes are contained in a chamber contains the water to be disinfected. A direct current (DC) power source (of a few volts) provides a current that causes the metal, such as silver, in the

anode to ionize and dissolve in the water. The concentration of metal ions in the water leaving the electrolytic cell depends on the current and water flow past the electrodes.

One of the earlier examples of this method is given in US patent 2,046,467 (1936),<sup>46</sup> which described a process to supply ionic silver to water by electrolysis, while the excess silver ion can be withdrawn or removed from the water electrolytically. This method was considered by NASA for its Apollo spacecraft water systems,<sup>47</sup> and now is being considered again by NASA for long duration missions.<sup>48</sup> A similar approach that does not require external power, is the electrochemical method, where water is purified with an immersed galvanic cell. The galvanic cell has a silver anode, which is electrically connected to a cathode made from a metal with higher electrochemical potential, such as platinum and palladium. Figure 3 depicts the top view and a cross-section view of the most preferred embodiment of the galvanic cell setup.<sup>49</sup> The figure depicts the layers of an anodic metal (14) positioned next to a cathodic metal (14a) sandwiched between two polyethylene or nylon layers forming a pouch.

In one of the examples, a strip of 2.5 cm by 5.0 cm silver metal and a 2.5 cm by 5.0 cm strip of platinized niobium expanded mesh was immersed in 200 mL of deionized (DI) water containing 5.25 ppm of sodium hypochlorite. The solution pH was 7.5. The silver and platinum strips were separated by a 0.5 mm thick polypropylene mesh and were electrically connected via a volt/ampere meter. The solution was agitated with a magnetic stirrer. The potential was 0.47 V and the current was 0.066 mA. The solution was analyzed for silver every 30 minutes using an atomic absorption spectrometer. The results are shown in Figure 4.

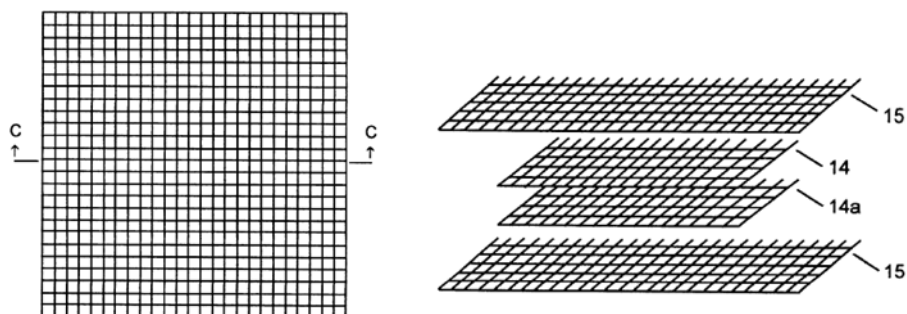

**Figure 3. Most preferred setup for a galvanic cell from US patent 6287450. The left is the top view, and the right is the cross section view, taken at aspect line C-C.**

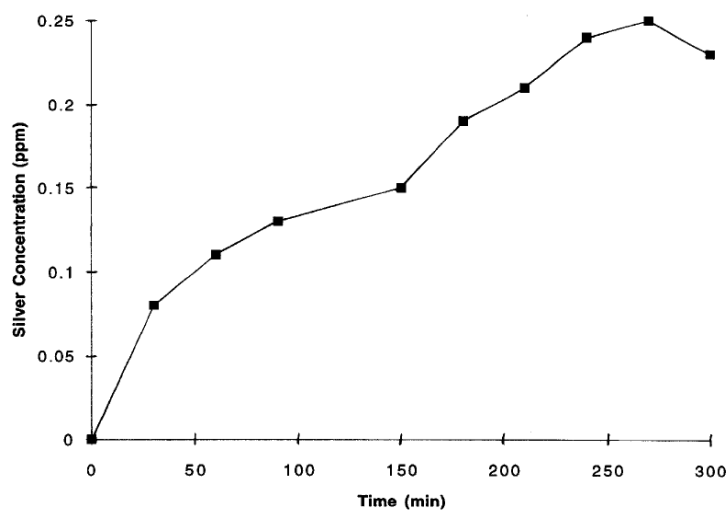

**Figure 4. A plot of the silver ion concentration as a function of time during the galvanic cell reaction between silver and platinum (US patent 6287450).**

## E. Polymer Nanocomposites

One way to make metal ions available is by incorporating metal nanoparticles into a polymer matrix. In contact with an aqueous environment, polymer-embedded nanoparticles are known to release metal ions due to corrosion and dissolution.<sup>50,51</sup>

AgNPs release ions quite efficiently because of their large specific surface area. The generation of silver ions occurs on the surface of the particles. Traces of gold or platinum in the AgNPs improve the silver ion release because the Au/Ag or Pt/Ag galvanic couple results in an enhanced oxidation of the silver.<sup>52</sup> The polymer properties also influence the silver ion release: the silver ion release rate increases with decreased crosslinking of the polymer, decreased hydrophobicity of the polymer, and the decreasing crystallinity of the matrix.

Damm and his coworkers<sup>50</sup> generated silver nanoparticles *in situ* in different polyamides by a thermal reduction of silver acetate during melting processing of the polymers. To prepare composites with a theoretical filler concentration of 2 wt%, 980 g of the polymer pellets were premixed with 31 g of silver acetate and then processed in a co-rotating twin-screw extruder. The processing temperatures ranged from 170 to 270°C for different polyamides. Figure 5 shows the transmission electron microscopy (TEM) micrographs of different polyamide/Ag nanocomposites. The long-term silver ions release increases with growing maximum water absorption of the polymer as well as the growing diffusion coefficient of water in the polymer.

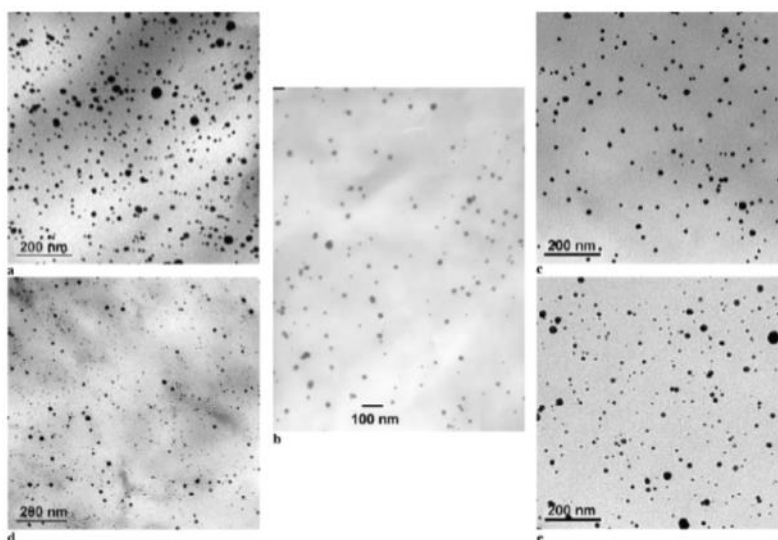

**Figure 5. TEM micrographs of polyamide/Ag nanocompositions.**<sup>50</sup>

Figure 6 shows the ion release behavior of the different silver nanocompositions. For hydrophilic polymers, plasticized by water, the silver ion release is a zero-order process (Figure 6a). For more hydrophobic polyamides, the silver ion release is governed by diffusion (Figure 6b).

The silver ion release tests were done by an indirect method. To investigate the silver ion release from the polyamide/Ag nanocomposites, rectangular silver specimens were immersed in distilled water. At defined times, the immersion liquid was exchanged completely. The concentration of silver ion in the solution was measured by anodic stripping voltammetry. This method is described briefly here, but more details can be found somewhere else.<sup>53</sup> A device consisting of a glassy carbon working electrode, a Ag/AgCl reference electrode, and a platinum wire counter electrode was used. The electrolyte was a 0.1M aqueous KNO<sub>3</sub> solution. In the first step of the experiment, a potential was applied to the working electrode that is more negative than the reduction potential of silver ions. During this first state of the experiment, the silver from the electrolyte is deposited on the working electrode. In the second stage, a potential scan is performed and the current is measured as a function of the potential. During the scan, the potential becomes more positive than the oxidation potential of silver, leading to a stripping of the silver

from the working electrode into the electrolyte. The silver ions released from the working electrode cause a peak in the current-potential curve. After a baseline correction, the area of the peak in the voltammogram is calculated. There is a linear relationship between the peak area and the silver ion concentration in solution. Thus, the silver ion concentration in the electrolyte can be determined from a calibration line.

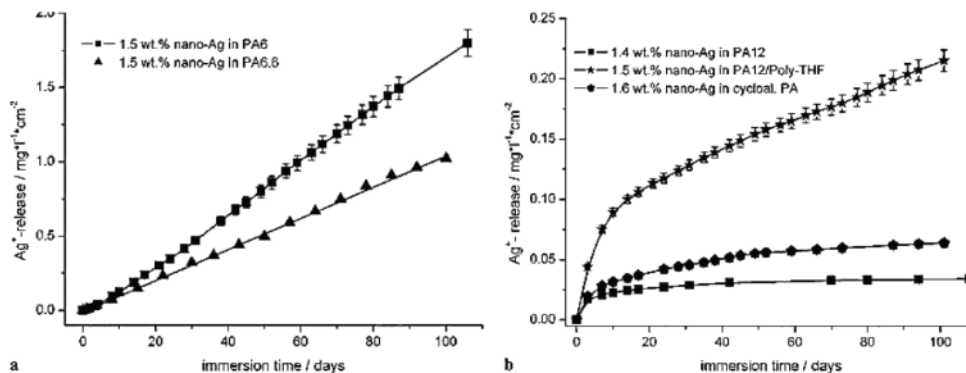

Figure 6. Cumulative silver ion release from the polyamide/Ag nanocompositions.<sup>47</sup>

## V. Silver Biocide Compatibility Studies for Spacecraft Systems

When using silver ion as a biocide, the choice of materials for the water system is important because surface reactions can reduce the biocide concentration below their effective range. There have been several investigations on this subject, some are summarized in Table 3. Alloys, such as stainless steel, Ni-based alloy, and titanium alloy, have been studied to determine material effect on silver depletion; different surface conditions were also compared to identify treatments to reduce silver loss; these studies were designed to represent the silver concentrations in potable water (200 to 500 ppb), and the conditional water (up to 500 ppm); different surface to volume ratios corresponding to the S/V range for water storage tank and tubing components in water distribution system were also examined.

Callahan *et al.*<sup>54</sup> studied stainless steel 21-6-9 tubing and Inconel 718 coupons using a solution containing 500 ppb silver ion, at S/V ratios 4.59 and 0.14. The effects of acid passivation and silver plating using 3 ppm silver ion solution (for 24 hours) was examined. It is clear that silver loss rates are slower at lower S/V ratios. Although surface passivation certainly has an effect on the silver depletion rate, the challenge in consistent passivation of small tubing must be overcome to achieve reliable results.

Roberts *et al.*<sup>55</sup> also compared stainless steel 21-6-9, 316L, and Inconel 718 coupons (acid passivated) for their effect on silver loss, using 500 ppb silver ion solution at S/V ratio 0.14, as a part of a microbial efficacy study. Although all three metals showed silver loss greater than 10% in three days, significant variations were observed across different metal types. After 21 days, the residual silver concentration is about 12%, 30%, and 70% for Inconel 718, SS 316L, and SS 21-6-9, respectively.

Adam<sup>56</sup> further studied the effect of S/V ratio using acid passivated stainless steel 316L and Inconel 718, as well as electropolished Inconel 718; tests were conducted using 500 ppb silver ion solution, at S/V ratios ranging from 0.2 to 8.2. This study clearly demonstrated that silver depletion rate increases with increasing S/V ratio, and, for Inconel 718, electropolishing is an effective surface treatment to reduce silver depletion.

Beringer *et al.*<sup>57</sup> disclosed some surface treatment methods to achieve long-term storage of silver biocide in portable water system in US patent 8,685,257. Through thermal oxidation at elevated temperature, such as 590°C for 2 hours, or silver plating by immersion using 50 or 25 ppm silver ion solutions, both Inconel 718 and stainless steel (E-Brite) can be treated to obtain surfaces that maintain a silver concentration about 0.35 to 0.39 ppm up to a year, at a low S/V ratio corresponding to full water tank configuration.

Recently, Petala and her coworkers<sup>58</sup> studied several substrates (Teflon, Ethylene propylene rubber, stainless steel 316L with different surface treatments, stainless steel 15-5 pH, and Ti6Al4V) in silver biocide solutions created by a silver ionization unit, at two silver ion levels, 0.5 ppm and 10 ppm, corresponding to the potable water and conditional water silver concentrations. A high S/V ratio (5) was selected to intensify the silver deposition

kinetics. It should also be noted that a mineral rich water formula, based on Russian ISS water, was used. All metallic samples resulted in complete or near complete depletion in the 0.5 ppm silver water, after 7 days of immersion. For the 10 ppm silver containing water, surface treatment had a greater impact on silver loss, with 316L passivated and electropolished surface resulting much less silver loss (21%), comparing to passivated 316L (95%). The XPS studies also showed that Ag<sup>0</sup> is the silver form on 316L sample surfaces,<sup>59</sup> while oxidized Ag present on the Ti6Al4V surface, the mechanism of the latter is yet to be determined.<sup>60</sup>

W. T. Wallace *et al.*<sup>61,62</sup> reported the effects of different surface treatments for Ti6Al4V and 316L on silver depletion using silver biocide solutions at different silver concentrations (0.4 ppm and higher). Both acid passivation and silver plating using high concentration (up to 500 ppm) silver solution can reduce silver loss rate for Ti6Al4V.

**Table 3. Summary of the Silver Compatibility Studies.**

Study	Testing Material			Testing Condition		Silver Loss Rate	
	Composition	Geometry	Surface Treatments	Silver Solution	S/V (cm <sup>-1</sup> )	Quantitative	Qualitative
Callahan <i>et al.</i> , 2007	SS 21-6-9	Tube	passivated	0.5 ppm (AgF)	4.59	10-20%/day	high
			passivated & Ag plated	0.5 ppm (AgF)	4.59	10-20%/day	high
	Inconel 718	washer	passivated	0.5 ppm (AgF)	0.14	1.5%/day	med
Roberts <i>et al.</i> , 2007	SS 21-6-9	Coupon 10×10×1.5 mm	passivated	0.5 ppm (AgF)	0.14	3% 1 <sup>st</sup> day; 30% after 21 days	med
	Inconel 718	same	passivated	0.5 ppm (AgF)	0.14	>10% first day; 88% after 21 days	high
	SS 316L	same	passivated	0.5 ppm (AgF)	0.14	>10% 1 <sup>st</sup> day; 70% after 21 days	high
Adam 2009	SS 316L	washer	passivated	0.5 ppm (AgF)	0.2, 0.5, 1.0, 5.0, 8.2	90% loss: 411, 190, 180, 63 hours for S/V 0.2, 0.5, 1.0, 5.0	high
	Inconel 718	washer	passivated	0.5 ppm (AgF)	0.2, 1, 8.2	90% loss (days): 32.1 (0.2), 1.4 (1.0)	high
	Inconel 718	washer	electropolished	0.5 ppm (AgF)	0.2, 1, 8.2	90% loss (days): 108.3 (0.2), 17.7 (1.0), 0.5 (8.2)	med & high
Beringer <i>et al.</i> , 2014	Inconel 718	Test panels	thermal oxidized & Ag plated	0.35 ppm (AgF)	0.14	maintain about 1 year	low
	SS (E-Brite)	Test panels	thermal oxidized & Ag plated	0.39 ppm (AgF)	0.14	maintain about 1 year	low
Petala <i>et al.</i> , 2016, 2017, 2018*	SS 316L	Test Panels 76×12.7×1.6 mm	120 grit sanded passivated (P) passivated & electropolished (P&E)	Electrolytic Ag 0.5 ppm	5.0	near 100% loss for all samples after 7 days	high
	SS 15-5	same	thermal oxidized	0.5 ppm	5.0	100% loss after 7 days	high
	Ti6Al4V	same		0.5 ppm	5.0	100% loss after 7 days	high
	FEP & PTFE	same		0.5 ppm	5.0	> 60% loss after 7 days	high
	EPR	same		0.5 ppm	5.0	Near 100% loss after 7 days	high
*Russian water formula with high mineral content	SS 316L	Test Panels 76×12.7×1.6 mm	120 grit sanded passivated (P) passivated & electropolished (P&E)	Electrolytic Ag 10 ppm	5.0	Ag loss after 7 days: 316L P&E (21%) vs 316L P (94.75%) 316L (97%)	high
	SS 15-5	same	thermal oxidized	10 ppm	5.0	loss after 7 days: 78%	high
	Ti6Al4V	same		10 ppm	5.0	loss after 7 days: 100%	high
	FEP & PTFE	same		10 ppm	5.0	loss after 7 days: FEP 15%, PTFE 5%	med
	EPR	same		10 ppm	5.0	loss after 7 days: 60%	high
Wallace <i>et al.</i> , 2016, 2017	SS 316L	Washer	passivated	0.4 ppm (AgF) After 100 ppm for 24 hours	0.61	residual Ag at 28 days (ppb): 25 (control 350)	high
	Ti6Al4V	Panel 0.7×0.5×0.12 in	passivated by 20% HNO <sub>3</sub>	Same as above	0.15	residual Ag at 28 days (ppb): 225 (control 350)	med
	Ti6Al4V	Panel 0.7×0.5×0.12 in	Ag plated at 500 ppm	Same as above	0.15	residual Ag at 28 days (ppb): 325 (control 350)	low

## VI. Microbial Control during Dormancy

Maintaining biocidal activity during periods of extended unattended configuration, commonly referred to as dormancy, is a challenge that must be addressed, based on lessons learned from the ISS first potable water dispenser (PWD) unit. This unit developed a major microbial contamination problem caused by system dormancy. Due to launch vehicle loading constraints, flight hardware must be delivered to the launch site several months before the launch. The first PWD unit was required to be delivered 6 months prior to the launch of STS-126 at the Kennedy Space Center in November 2008. The PWD system remained unpowered and stagnant from the time of delivery until activation aboard the ISS. Although the final fluid line disinfection at the Johnson Space Center, using 20-30 ppm iodine (I<sub>2</sub>), resulted in no detectable bacteria within the fluid lines at the time of disinfection, microbial growth

occurred during the dormancy period and was identified shortly after activation when samples were drawn from the PWD for analysis.<sup>63</sup>

Future crewed missions beyond lower Earth Orbit may include intermittent periods of dormancy. This has been identified as a critical issue for future missions, due to concerns of microbial growth or chemical degradation that would prevent water systems from operating properly when the mission began. The mission requirement includes the capability for life support systems to support crew activity, followed by a dormant period of up to one year, and subsequently for the life support systems to come back online for additional crewed missions. As such, it is critical that the water system be designed to accommodate this dormant period.<sup>64,65</sup> If technology development results in the delivery of materials or coatings that prevent plating of silver, then no additional measures will be required to sustain the potable tank during dormancy.

## VII. Summary

### A. Biocidal Activity of Silver

#### 1. Mechanism

Silver ion is a powerful broad spectrum biocide that is relatively safe to humans. A complete understanding of the biocidal activity of silver is yet to be achieved, but there is a general agreement that silver ions demonstrate versatile biocidal functions through different mechanisms, such as interaction with membrane proteins, blocking respiration and electron transfer across the cell wall, interaction with DNA and proteins inside the cell, and inducing ROS.

The biocidal effect of AgNPs originates from the silver ions on their surface and the increased bioavailability due to their large surface area. Some AgNPs, especially the ones with [111] facets, can anchor to and penetrate the cell wall, which greatly enhances their biocidal power.

#### 2. Human exposure

Silver can be considered safe to humans at the effective biocide level. Exposure to a high dose of silver ions can result in discoloration of the skin, but no further toxic effects have been validated so far. Caution should be taken when dealing with silver nanoparticles, due to their size and increased bioavailability.

#### 3. Silver Resistance

Silver resistance has been confirmed in different bacteria, though its mechanism(s) is not well understood. For long-term applications, it is important to take precautions to prevent the development of bacterial resistance to silver biocide. This requires identifying a complement biocide, alternating biocides on a regular basis, and periodically eliminating the entire bacterial population with a different biocide or UV device, or heat.

### B. Silver Ion Dosing Systems

Several classes of silver ion dosing systems have been reported in the literature: (1) silver or silver compounds coated filtrating media, (2) silver containing ion exchangers, (3) electrolytic generators and electrochemical methods, and (4) polymer/silver composites.

In the first category of dosing systems, silver compounds simply release silver ions through dissolution from the surface of filtrating media. The release rate is likely a combination of solubility, contact area, and contact time with water. The solubilities of different silver compounds vary vastly. The only compounds that have a solubility that is close to the target silver concentration are AgBr (~ 80 ppb) and AgCl (1400 ppb). In the case of AgNPs, the silver ion is likely released from the particle surface which is oxidized. It is worth noting that activators, such as a traces of gold and platinum, can be used to promote silver ion release.

The second category of dosing systems, silver-containing cation ion exchangers, relies on the ion exchange action to release silver. The release rate strongly depends on the ion concentration in the water, as it is to be expected. The release rate of a cation exchange resin in a silver form, such as Ag-sulfonic acid resin and Ag-zeolite, is often too high to be safe for human consumption, even in distilled water. Chelating resins can be used to reduce the ion release rate, often hundreds fold. Compared to ion exchange resins, inorganic ion exchangers lack structural integrity and their release rates are also too high, but when incorporated into a polymer matrix, these problems can be addressed and some of the composites show great potentials for long-term stable release, at a safe, yet effective, silver ion level.

The third category of dosing systems, electrolytic ion generators or electrochemical method, uses the corrosion process of silver metal with or without applied potential. The silver ion release rate is in proportion with the corrosion rate and the total surface area corroding.

The fourth category, polymer composite containing nanoparticles of silver or silver compound, takes advantage of the large surface area of AgNPs, for effective ion release, and the structure integrity of polymer matrix, which can also be tuned to control the release rate.

Essentially, each silver ion delivery system includes a silver ion source and a diffusion/transport media. The silver ion source can be a silver compound that is already in the ionic form, such as a silver compound coated filtrating media, silver containing ion-exchanger, and polymer/silver compound nanocomposite; or the silver ion source can be silver metal, that will go through a chemical or electrochemical oxidation process to become an oxide or other silver compound, such as silver coated filtrating media, silver electrode in electrolytic ion generator or electrochemical method, and polymer/silver nanocomposite. The media for silver ion release can be the filtrating media, the ion exchange resin, the inorganic ion exchanger, or the polymer matrix in polymer nanocomposites.

The release rate of each delivery system is a function of the properties of the silver ion source and the diffusion/transport media. Three properties of the silver ion source are critical to the release rate: (1) the solubility of the silver compound, (2) the surface/interfacial area where the silver ions are released, and (3) the conversion rate of silver metal to silver ion, if the silver ion source is metallic silver. The most important property of the diffusion media is the diffusion efficiency of silver ions and its counter ions, and in the case of cation ion exchanging resin, the diffusion efficiency and the concentration of the exchanging cations in the media and environment.

To avoid developing silver resistance, a connection can be built in the potable water system, so that it is possible to use heat to kill the entire microbe population periodically, and it is important not to use high dose silver ion to achieve this goal. To avoid biofilm growth, it is essential that the design of the potable water system allows physical cleaning by a method, such as sonication, to reduce the overall nutrient level inside the system. By combining physical cleaning and an alternative sterilization mechanism with a reliable silver ion delivery system, clean water can be enjoyed by the crew on their long-term duration exploration missions.

### C. Silver Biocide Compatibility

When using silver ion as a biocide, the choice of materials for the water system is important because surface reactions can reduce the biocide concentration below their effective range. There have been several investigations on this subject, some are summarized in Table 3.

### D. Microbial Control during Dormancy

Maintaining the effectiveness of silver as a biocide, during periods of stagnation, is a challenge that must be addressed when designing potable water systems for future crewed missions beyond lower Earth Orbit that may include intermittent periods of dormancy.

## Acknowledgments

The authors would like to acknowledge funding from the Advanced Exploration Systems (AES) Life Support Systems (LSS).

## References

---

<sup>1</sup> <https://www.katadyn.com/us/us/water-know-how/types-of-contamination>

<sup>2</sup> <https://www.katadyn.com/us/us/water-know-how/types-of-filters>

<sup>3</sup> "U.S. Nanomaterial Case Study: Nanoscale Silver in Disinfectant Spray (Final Report)," U. S. Environmental Protection Agency, Washington, DC, EPA/600/R-10/081F, 2012.

<sup>4</sup> Fewtrell, L., Silver: "Water Disinfection and Toxicity," WHO Centre for Research into Environment and Health, 2014.

<sup>5</sup> Alekseenko, V., and Alekseenko, A., "The abundances of chemical elements in urban soils," *Journal of Geochemical Exploration*, Vol 147, 2014, pp. 245-249.

<sup>6</sup> O'Neil, M.J. (Ed.), *The Merck Index: An Encyclopedia of Chemicals, Drugs, and Biologicals*, 13th ed. New Jersey: Merck, 2001.

<sup>7</sup> Lide, D.R. (Ed.), (2000-2001), *CRC Handbook of Chemistry and Physics* (82<sup>nd</sup> ed.), CRC Press, Boca Raton, FL.

<sup>8</sup> Comey, A. M. and Hahn, D. A., (1921), *A Dictionary of Chemical Solubilities: Inorganic* (2nd ed.), The MacMillan Company, New York, NY.

<sup>9</sup> Choi *et al.*, "Role of Sulfide and Ligand Strength in Controlling Nanosilver Toxicity," *Water Research*, Vol. 43, 2009, pp. 1879-1886.

- 
- <sup>10</sup> Maccuspie *et al.*, "Colloidal Stability of Silver Nanoparticles in Biologically Relevant Conditions," *Journal of Nanoparticle Research*, Vol. 13, 2011, pp. 2893-2908.
- <sup>11</sup> Silver, S., Phung, I., and Silver, G., "Silver as Biocides in Burn and Wound Dressings and Bacterial Resistance to Silver Compounds," *Journal of Industrial Microbiology and Biotechnology*, Vol. 33, No. 7, 2006, pp. 627-634.
- <sup>12</sup> Bragg, P. D. and Rainnie, D. J., "The Effect of Silver Ions on the Respiratory Chains of Escherichia Coli," *Can. J. Microbiol.*, Vol. 20, 1974, pp. 883-889.
- <sup>13</sup> Feng, Q. L., Chen, G. Q., Cui, F. Z., Kim T. N., and Kim, J. Q., "A Mechanistic Study of the Antibacterial Effect of Silver Ions on Escherichia Coli and Staphylococcus Aureus," *Journal of Biomedical Materials Research*, Vol. 52, No. 4, 2000, pp. 662-668.
- <sup>14</sup> Gordon, O., *et al.*, "Silver Coordination Polymers for Prevention of Implant Infection: Thiol Interaction, Impact on Respiration Chain Enzymes, and Hydroxyl Radical Induction," *Antimicrobial Agents and Chemotherapy*, Vol. 54, No. 10, 2010, pp. 4208-4218.
- <sup>15</sup> Milnendonckx, K., Leys, N., Mahillon, J., Silver, S., and Houdt, R. V., "Antimicrobial Silver: Uses, Toxicity and Potential for Resistance," *Biometals*, Vol. 26, No. 4, 2013, pp. 609-621.
- <sup>16</sup> McDonnell, G. and Russell, A. D., "Antiseptics and Disinfectants: Activity, Action, and Resistance," *Clinical Microbiology Reviews*, Vol. 12, No. 1, 1999, pp. 147-179.
- <sup>17</sup> Lok, C-N., Ho, C-M., Chen, R., He, Q-Y., Yu, W-Y., Sun, H., Tam, P.K-H., Chiu, J-F., and Che, C-M, "Silver nanoparticles: partial oxidation and antibacterial activities," *Journal of Biological Inorganic Chemistry*, Vol 12, 2007, pp.527-534.
- <sup>18</sup> Pal, S., Tak, Y. K., and Song, J. M., "Does the Antibacterial Activity of Silver Nanoparticles Depend on the Shape of the Nanoparticle? A Study of the Gram-Negative Bacterium Escherichia Coli," *Applied and Environmental Microbiology*, Vol. 73, No. 6., 2007, pp. 1712-1720.
- <sup>19</sup> Bashir, S., Chamakura, K., Perez-Ballesteros, R., Luo, Z., and J. Liu, "Mechanism of Silver Nanoparticles as a Disinfectant," *International Journal of Green Nanotechnology*, Vol. 3, No. 2, 2011, pp. 118-133.
- <sup>20</sup> Faust, R. A., "Toxicity Summary for Silver," Oak Ridge Reservation Environmental Restoration Program, 1992.
- <sup>21</sup> Bruins, M.R., Kapil, S., and Oehme, F. W., "Microbial Resistance to Metals in the Environment," *Ecotoxicology and Environmental Safety*, Vol. 45, No. 3, 2000, pp. 198-207.
- <sup>22</sup> Silver, S., and Phug, L. T., "Bacterial Heavy Metal Resistance: New Surprises," *Annual Review of Microbiology*, Vol. 50, 1996, pp. 753-89.
- <sup>23</sup> Rohr, U., Senger, M., Selenka, F., Turley, R. and Wilhelm, M., "Four Years of Experience with Silver-Copper Ionization for Control of Legionella in a German University Hospital Hot Water Plumbing System," *Clinical Infectious Diseases*, Vol. 29, No. 6, 1999, pp. 1507-11.
- <sup>24</sup> Clement, J. L. and Jarrett, P. S., "Antibacterial Silver," *Metal-Based Drugs*, Vol. 1, No. 5-6, 1994, pp. 467-482.
- <sup>25</sup> Trevors, J. T., "Silver Resistance and Accumulation in Bacteria," *Enzyme and Microbial Technology*, Vol. 9, No. 6, 1987, pp. 331-333.
- <sup>26</sup> Meyer, W. C., "Coping with Resistance to Copper/Silver Disinfection," *Water Engineering & Management*, November 2001, pp. 25-27.
- <sup>27</sup> Schreier, A., "Process and Material for Sterilization of Liquids," US Patent 1,642,089, Sept. 13, 1927.
- <sup>28</sup> Krause, G. A., "Process for the Sterilization of Liquids," US Patent 1,988,246, Jan. 15, 1935.
- <sup>29</sup> Piccione, S., "Impregnation of Carbon with Silver," US Patent 3,294,572, Dec. 27, 1966.
- <sup>30</sup> Mitsumori *et al.*, "Method of Treating Silver Impregnated Activated Carbon," US Patent 4,045,553, Aug. 30, 1977.
- <sup>31</sup> Argyle, M. D. and Bartholomew, C. H., "Heterogeneous Catalyst Deactivation and Regeneration: A Review," *Catalysts*, Vol. 5, 2015, pp. 145-269.
- <sup>32</sup> Bechhhhold, H., "Filter," US Patent 1,473,331, Nov. 6, 1923.
- <sup>33</sup> Quinn, D. H., "Water Purification," US Patent 2,595,290, May 6, 1952.
- <sup>34</sup> Quinn, D. H., "Water Filter," US Patent 2,566,371, Sep. 4, 1951.
- <sup>35</sup> Pall, D. B., "Sterilization of Water," US Patent 3,257,315, June 21, 1966.
- <sup>36</sup> Ham, G. P., "Bacteria-Resistant Elastomers Containing Silvered Anion-Exchange Resins," US Patent 2,578,186, Dec. 11, 1951.
- <sup>37</sup> Walter, J., "Method of and Apparatus for Sterilizing Liquids," US Patent 2692855, Oct. 26, 1954.
- <sup>38</sup> Marchin, G. L. and Lambert, J. L., "Method of Treating Water with Resin Bound Ionic Silver," US Patent 5,366,636, Nov. 22, 1994.
- <sup>39</sup> Calmon, C. and Grundner, W. T., "Preparation and Use of Silver Zeolites of Improved Exchange Capacity," US Patent 3382039, May 7, 1968.
- <sup>40</sup> Hu, P. C., "Biocidal Zeolite Particles," US Patent 5,256,390, Oct. 26, 1993.



- 
- <sup>41</sup> Hagiwara, Z. *et al.*, “Zeolite Particles Retaining Silver Ions Having Antibacterial Properties,” US Patent 4,911,898, March 27, 1990.
- <sup>42</sup> Troup, J. M. and Clearfield, A., “On the Mechanism of Ion Exchange in Zirconium Phosphates. 20. Refinement of the Crystal Structure of  $\alpha$ -Zirconium Phosphate,” *Inorganic Chemistry*, Vol. 16, No. 12, 1977, pp. 3311-3314.
- <sup>43</sup> Saengmee-anupharb, S., *et al.*, “Antimicrobial Effects of Silver Zeolite, Silver Zirconium Phosphate Silicate and Silver Zirconium Phosphate against Oral Microorganisms,” *Asian Pacific Journal of Tropical Biomedicine*, Vol. 3, No. 1, 2013, pp. 47-52.
- <sup>44</sup> Barhon, Z. *et al.*, “Effect of Modification of Zirconium Phosphate by Silver on Photodegradation of Methylene Blue,” *J. Mater. Environ. Sci.*, Vol. 3, No. 5, 2012, pp. 879-884.
- <sup>45</sup> Sugiura, K., “Antibacterial Processing Agent for Water Treatment, Method for Producing Antibacterial Processing Agent For Water Treatment, and Water Treatment Method,” WO 2011114976 A1, Sep 22, 2011.
- <sup>46</sup> Krause, G. A., “Sterilization of Liquids by Means of Oligodynamy,” US Patent 2,046467, July 7, 1936.
- <sup>47</sup> Albright, C. F., Nachum, R., and Lechtman, M. D., “Development of an Electrolytic Silver-Ion Generator for Water Sterilization in Apollo Spacecraft Water Systems,” NASA-CR-65738, REPT-67-2158, 1967.
- <sup>48</sup> Slote, B. M., Salley, E., Carr, D., Kimble, M. C., “Silver Ion Biocide Delivery System for Water Disinfection,” 46<sup>th</sup> International Conference on Environmental Systems, ICES-2016-136, 10-14 July 2016, Vienna, Austria.
- <sup>49</sup> Hradil, G., “Apparatus and Method for Purifying Water with an Immersed Galvanic Cell,” US Patent 6,287,450 B1, Sep. 11, 2001.
- <sup>50</sup> Damm, C. and Münstedt, H., “Kinetic Aspects of the Silver Ion Release from Antimicrobial Polyamide/Silver Nanocomposites,” *Applied Physics A*, Vol. 91, No. 3, 2008, pp. 479–486.
- <sup>51</sup> Hahn, Brandes, A., Wagner, G., and Barcikowski, P., S., “Metal ion Release Kinetics from Nanoparticle Silicone Composites,” *Journal of Controlled Release*, Vol. 154, No. 2, 2011, pp. 164-170.
- <sup>52</sup> Zaporojtchenko, V., Podschun, R., Schürmann, U., Kulkarni, A., and Faupel, F., “Physico-Chemical and Antimicrobial Properties of Co-Sputtered Ag–Au/PTFE Nanocomposite Coatings,” *Nanotechnology*, Vol. 17, 2006, pp. 4904-4908.
- <sup>53</sup> Damm, C., Munstedt, H., and Rosch, A., “Long-Term Antimicrobial Polyamide 6/silver-nanocomposites,” *J. Mater Sci*, Vol 42, 2007, pp.6067-6073.
- <sup>54</sup> Callahan, M. R., Adam, N. M., Roberts, M. S., Garland, J. L., Sager, J. C., and Pickering, K. D., “Assessment of Silver Based Disinfection Technology for CEV and Future US Spacecraft,” SAE Technical Paper 2007-01-3258, 2007
- <sup>55</sup> Roberts, M.S., Hummerick, M. E., Edney, S. L., Bisbee, P. A., Callahan, M. R., Loucks, S., Pickering, K. D., and Sager, J. C., “Assessment of Silver Based Disinfection Technology for CEV and Future US Spacecraft: Microbial Efficacy,” SAE Technical Paper 2007-01-3142, 2007
- <sup>56</sup> Adam, N. M., “Compatibility Study of Silver Biocide in Drinking Water with Candidate Metals for the Crew Exploration Vehicle Potable Water System,” SAE Technical Paper 2009-01-2459, 2009
- <sup>57</sup> Beringer, D. M., Steele, J. W., Nalette, T. A., “Long-Term Storage of Potable Water in Metallic Vessels,” US 8,685,257B2.
- <sup>58</sup> Petala, M., Tsiridis, V., Darakas, E., Mintsouli, I., Sotiropoulos, S., Kostoglou, M., Karapantsios, T., and Rebeyre, P., “Silver Deposition on Wetted Materials Used in the Potable Water Systems of the International Space Station,” 46<sup>th</sup> International Conference on Environmental Systems, ICES-2016, 10-14 July 2016, Vienna, Austria.
- <sup>59</sup> Petala, M., Tsiridis, V., Mintsouli, I., Pliatsikas, N., Spanos, T., Rebeyre, P., Darakas, E., Patsalas, P., Vourliasc, G., Kostoglou, M., Sotiropoulos, S., Karapantsios, T., “Silver Deposition on Stainless Steel Container Surface in Contact with Disinfectant Silver Aqueous Solutions,” *Applied Surface Science*, Vol 396, 2017, pp.1067-1075.
- <sup>60</sup> Mintsouli, I., Tsiridis, V., Petala, M., Pliatsikas, N., Rebeyre, P., Darakas, E., Kostoglou, M., Sotiropoulos, S., and Karapantsios, T., “Behavior of Ti-6Al-4 V surfaces after exposure to water disinfected with ionic silver,” *Applied Surface Science*, Vol 427, 2018, pp. 763-770
- <sup>61</sup> Wallace, W. T., *et al.*, “Effects of Material Choice on Biocide Loss in Orion Water Storage Tanks,” 46<sup>th</sup> International Conference on Environmental Systems, ICES-2016, 10-14 July 2016, Vienna, Austria.
- <sup>62</sup> Wallace, W., Wallace, S., Loh, L., Kuo, C., Hudson Jr., E., Marlar, T., Gazda, D., “Effects of Materials Surface Preparation for Use in Spacecraft Potable Water Storage Tanks,” *Acta Astronautica* Vol 141, 2017, pp. 30-35.
- <sup>63</sup> Maryatt, B. W. and Smith, M. J., “Microbial Growth Control in the International Space Station Potable Water Dispenser,” 47<sup>th</sup> International Conference on Environmental Systems, ICES-2017, 16-20 July 2017, Charleston, South Carolina.
- <sup>64</sup> Tabb, D. and Carter, D. L., “Water Recovery System Design to Accommodate Dormant Periods for Manned Missions,” 45<sup>th</sup> International Conference on Environmental Systems, ICES-2015, 12-16 July 2015, Bellevue, Washington.
- <sup>65</sup> Carter, D. L., Tabb, D., and M. Anderson, “Water Recovery System Architecture on Operational Concepts to Accommodate Dormancy,” 47<sup>th</sup> International Conference on Environmental Systems, ICES-2017, 17-20 July 2017, Charleston, South Carolina.