

Investigation into New Ground Based Communications Service Offerings in Response to SmallSat Trends

Scott Schaire, Serhat Altunc, Yen Wong, Obadiah Kegege, Marta Shelton, George Bussey
NASA Goddard Space Flight Center
Greenbelt, MD 20771, USA; 757-824-1646
scott.h.schaire@nasa.gov

Marcus Murbach
NASA Ames Research Center
Moffett Field, CA 94035; 650-604-3155
marcus.s.murbach@nasa.gov

Howard Garon
ASRC Federal Space and Defense
Beltsville, MD 20705; 301-286-4387
howard.garon@nasa.gov

Yudhajeet Dasgupta, Steve Gaines, Edward McCarty, Sean McDaniel
ATLAS Space Operations
Traverse City, MI 49684; 231-598-6184
ydasgupta@atlasground.com

Wesley Faler
Miles Space
Tampa, FL 33607; 475-282-3728
wes@miles-space.com

Peter Celeste, Trish Perrotto
Booz Allen Hamilton
Annapolis Junction, MD 20701; 321-972-4136
celeste_peter@bah.com

Matt Batchelor
Aerospace Engineering Student at Rensselaer Polytechnic Institute
Troy, NY 12180; 541-913-0030
batchm@rpi.edu

ABSTRACT

The number of NASA sponsored Small Satellite (SmallSat) missions is expected to continue to grow rapidly in the next decade and beyond. There is a growing trend towards more ambitious SmallSat missions, including formation flying (Constellation, Cluster, Trailing) SmallSats and SmallSats destined for lunar orbit and beyond. This paper will present an overview of new service offerings the NASA Near Earth Network (NEN) is currently investigating and demonstrating. It will describe the benefits that new service offerings such as Multiple Spacecraft Per Aperture (MSPA), Ground-based Phased Array (GBPA) antennas, Ground-based Aperture Arrays, and Ground-based Antenna Arraying could provide to individual or formation flying SmallSats anywhere from low-earth orbit to the Sun-Earth Lagrange point orbits. It will also present potential implementation options for future demonstrations at the NASA Goddard Space Flight Center (GSFC) Wallops Flight Facility (WFF) as well as goals and objectives of such demonstrations.

INTRODUCTION

The NASA Space Communication and Navigation (SCaN) Program Office manages three networks for telemetry, tracking, command and launch and early orbit support for NASA missions. The Deep Space Network (DSN) supports exploration missions to furthest points of the solar system. The Space Network (SN) consists of a constellation of geosynchronous (Earth orbiting) satellites named the Tracking and Data Relay Satellite (TDRS).

The Near Earth Network (NEN) is a ground network primarily concerned with supports from the Earth out to the moon and Lagrange points L1/L2, approximately 2 km from earth.

NEN assets include NEN-owned and commercial tracking stations, located throughout the world. The NEN-owned facilities are located at Wallops Island in Virginia; McMurdo Ground Station in Antarctica; White Sands in New Mexico; Kennedy Uplink Station and Ponce De Leon in Florida; and Alaska Satellite Facility in Fairbanks. Currently, the NEN provides support from 16 locations around the globe from over 35 different apertures See Figure 1.

The NEN currently supports about 40 NASA missions across all NASA Directorates. Although most of NEN's current missions are medium and large satellite, some are small satellite, such as the Time History of Events and Macroscale Interactions during Substorms (THEMIS) series of five small satellites. Launched in 2007, each spacecraft weighs 282 lbs. (128 kg), about the equivalent of 94U CubeSats (3lbs per U). The NEN is currently well positioned to service emerging Small Satellite (SmallSat) and CubeSat missions. The NEN continues to investigate additional capabilities that will make the NEN even more applicable to the SmallSat community.

With more and more SmallSats and CubeSats being launched by NASA and others, there is an increasing need to better manage and allocate ground station time within the NEN. High traffic areas require more

antennas driven by a need to have one antenna per satellite in view by the ground station site. For example, the NEN currently has 10 antennas by the north pole to provide simultaneous coverage to polar orbiting spacecraft. A low-cost solution for supporting multiple targets per antenna would be the ideal alternative to the addition of ground antennas.

The NEN antennas are typically 11-meter diameter and receive at X-band and S-band. The NEN does have an 18-meter antenna at White Sands for Ka-band and S-band and is in the process of adding additional Ka-band assets. While an 11-meter diameter provides adequate gain for spacecraft in low earth orbits, larger diameter antennas are needed for spacecraft at lunar and L1/L2 distances. Applying arraying technology (i.e. combining antennas) provides the performance of a much larger, more expensive antenna.

Use of NEN-compatible radios by SmallSats will allow SmallSats to utilize the NEN as it exists today as well as the new service offerings the NEN plans to implement in the future. One example of a NEN-compatible radio is the Commercial Off the Shelf (COTS) Ettus Research USRP B200mini radio. The USRP B200mini S-band radio will provide SmallSat projects a cost effective alternative radio option for missions at lunar, L1/L2, and Mars distances. The USRP B200mini radio will be used for communications by several upcoming NASA CubeSat missions. The USRP B200mini will fly on TechEdSat-8, which will operate in a low earth orbit. TechEdSat-8 is currently targeted for launch in December 2018. The USRP B200mini will also fly on the Team Miles CubeSat, a secondary payload on Exploration Mission 1 (EM-1) that is destined for an orbit close to Mars. The Team Miles CubeSat is targeted for a launch in December 2019, and the prior use of the USRP B200mini radio by TechEdSat-8 will result in a risk reduction for the Team Miles CubeSat.

This paper discusses various potential new service offerings including multiple spacecraft per aperture (MSPA), Ground-based Phased Array (GBPA), Ground-based Aperture Array, Ground-based Antenna Arraying as well as future demonstration of these technologies.

THE NEAR EARTH NETWORK PROJECT

National Aeronautics and Space Administration

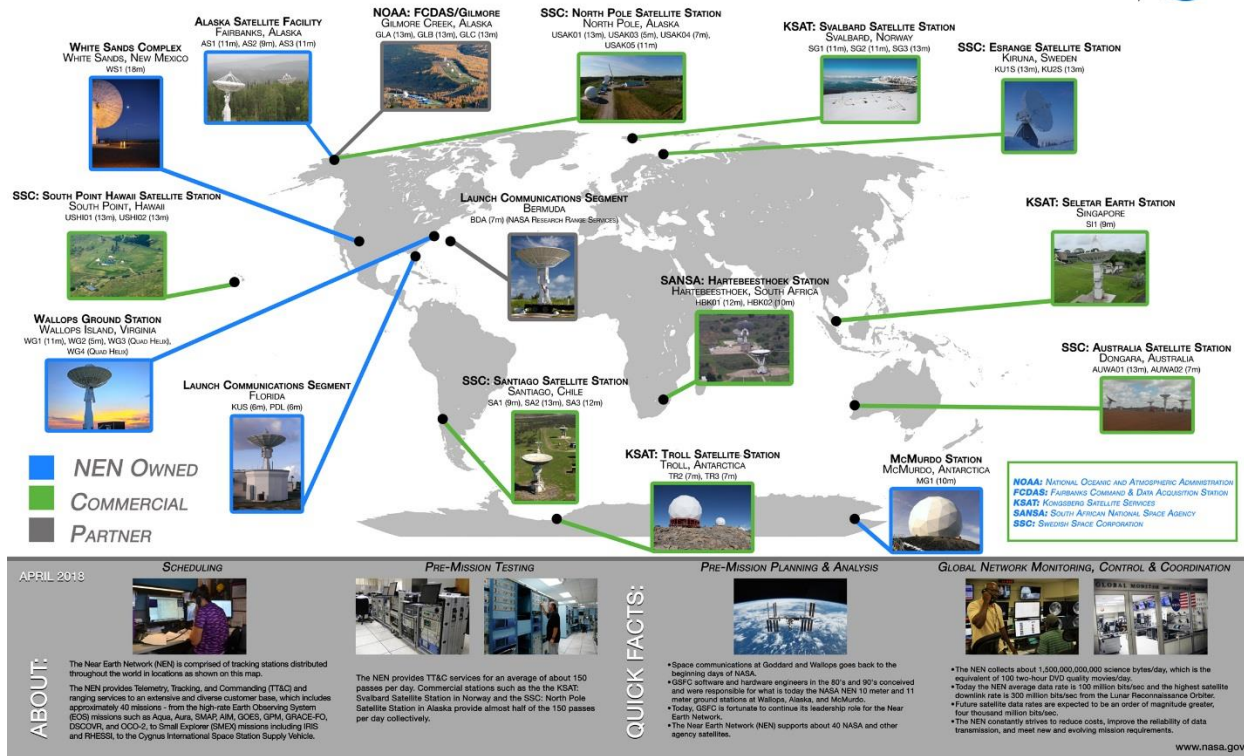

Figure 1 The NEN provides communication services for various low-Earth orbits (LEO), geosynchronous orbits (GEO), highly elliptical orbits (HEO), LaGrange orbits, lunar and suborbital, and launch trajectories.

OVERVIEW OF NEW SERVICE OFFERINGS BEING INVESTIGATED

The NEN has begun to investigate candidate options for enhancing its service offering related to capacity and performance. As mentioned in the Introduction, solutions that could increase the number of customers the NEN can support while minimizing the number of apertures required would potentially provide cost savings for the NEN and its customers while increasing the available antenna time for NEN customers. Likewise, advances in capabilities to increase NEN's performance without the need for additional large, and often more expensive, apertures could put the NEN in a better position to support satellites in lunar orbit and beyond. This added NEN capability would provide projects planning missions in the lunar and Lagrangian orbit regimes that will use NEN-compatible radios an alternative network to consider for prime or contingency support.

Simultaneous Support to Multiple Spacecraft

The number of NASA SmallSat/CubeSat missions is expected to grow rapidly in the next decade and beyond.¹ The significant increase in missions requiring support could become a resource allocation challenge for the NEN. The NEN is investigating different techniques that would potentially enable the NEN to reduce network loading and provide cost savings to upcoming customers, especially, SmallSat constellations and SmallSats flying in formation. Different techniques being explored include MSPA, GBPA, and Ground-based Aperture Array.

MSPA has been demonstrated by the DSN successfully and the NEN is working on a future demonstration. The Ground-based Phased Array section describes a demonstration conducted at NASA Goddard Space Flight Center (GSFC) Wallops Flight Facility (WFF) in 2004. NASA and ATLAS Space Operations are collaborating to test and develop Ground-based Aperture Array technology. A demonstration was

completed at NASA GSFC WFF in April 2018. The ATLAS LINKS, a Ground-based Aperture Array, can accept data from multiple spacecraft simultaneously, which could boost communications for SmallSats.

Antenna Arraying for Increased Performance

Ground-based Antenna Arraying can have multiple benefits. Scientists' aiming to return higher resolution data or increase the number of instruments on-board a spacecraft require higher data rates, and this drive goes hand in hand with the enabling technologies. A ground station having multiple smaller apertures has scheduling and cost benefits, while keeping beamwidths wide - a benefit to communications. Now, with technology that combines multiple ground station antennas, arraying can achieve the data rates and performance of a much larger antenna with the equivalent size of their combined areas. The improvement in the G/T of the antenna arraying is a function of the number of elements added. Assuming identical elements, the incremental improvement in array G/T ranges from 3 dB with 2 elements, to 12 dB with 16 elements.² Using multiple antennas arrayed together also increases reliability in case of loss of signal with one of the antennas.

MULTIPLE SPACECRAFT PER APERTURE

MSPA is a technique that has been used for over a decade to increase the efficient utilization of ground network assets while decreasing the antenna cost allocated to missions. The key requirements for MSPA are:

1. All spacecraft must be within the beamwidth of the requested station
2. All spacecraft must operate on different uplink and downlink frequencies and have polarizations consistent with the station antenna
3. Commands can only be sent to the spacecraft having the uplink
4. High quality tracking data can only be obtained from spacecraft operating in the coherent mode.

Given these requirements, the types of SmallSats that could benefit from MSPA include super tight trains or clusters within low earth orbit to constellation and formation flying SmallSats in more distant orbits. The "MSPA Antenna Beam Width Study" subsection provides the results of a NEN analysis looking at candidate orbits and mission types.

Figure 2 and Figure 3 illustrate the traditional MSPA and Opportunistic MSPA concepts.

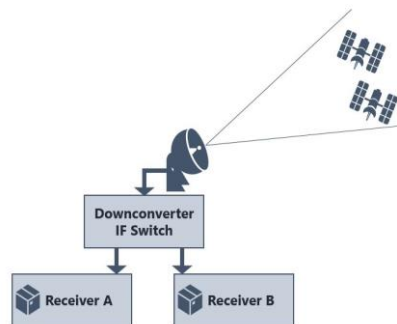

Figure 2 Traditional MSPA Signal Flow

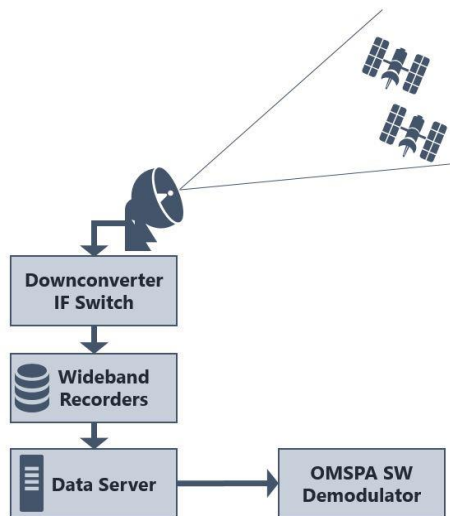

Figure 3 Opportunistic MSPA Signal Flow

With the traditional MSPA technique, each of the missions that will be within the same beamwidth of a ground antenna must be equipped with a separate receiver; for example, a ground antenna supporting two missions within the same beamwidth using traditional MSPA will require two receivers, a ground antenna supporting three missions simultaneously using traditional MSPA will require three receivers. With Opportunistic MSPA, a wideband recorder that is capable of capturing IF signals from each spacecraft in the antenna beam within the frequency bands of interest is employed at a station, rather than additional receivers. Spacecraft can opportunistically transmit open loop when in a host spacecraft's antenna beam. Via a server on an Internet site, the mission operators can then retrieve relevant data files from the wideband recorder for subsequent demodulation, decoding, and frame processing.

Today, NASA JPL has performed proof-of concept demonstrations of both traditional MSPA and OMSPA.³ In the OMSPA demonstration, Mars Odyssey was considered the SmallSat and Mars Reconnaissance

Orbiter was considered the host spacecraft. With the success of the proof-of-concept demonstration, JPL DSN is considering implementing OMSPA as an alternative downlink service in the future.

MSPA Antenna Beam Width Study

A study has been performed to investigate the possibility and suitability of NEN MSPA support using NEN station antenna beamwidth as a measure.

The study modeled NEN ground station antenna beamwidths at S and X bands for LEO, MEO, GEO and Lunar orbits. The results are shown in the tables below. The range in values in beamwidth calculations in Table 1 are based on spacecraft altitudes between 160 km (lower beamwidth) and 2,000 km (higher

beamwidth). Beamwidth calculations in Table 2 assume a spacecraft altitude of 20,350 km. Beamwidth calculations in Table 3 assume a spacecraft altitude of 35,786 km. Beamwidth calculations in Table 4 are based on a lunar distance of 384,400km, and percent lunar coverage is based on the dividing the beamwidth by the lunar diameter (i.e., 3,474 km).

There are large differences in beamwidths at different altitudes and elevations from the horizon. Dish diameters and frequencies were selected to best represent what is utilized by the NEN: 6.1-m, 11.3-m, and 13-m antennas considered; S-band (2290 MHz) and X-band (8500 MHz). Tracking was assumed to be acquired at 4 degrees above the horizon. Overhead and Horizon beamwidths were examined due to their being the extreme cases.

Table 1 LEO Beamwidth Results

	6.1m		11.3m		13m	
	On Horizon	Direct Over-flight	On Horizon	Direct Over-flight	On Horizon	Direct Over-flight
S-band Beam-width	30.0 km to 141.8 km	4.5 km to 56.7 km	16.2 km to 76.6 km	2.4 km to 30.6 km	14.1 km to 66.6 km	2.1 km to 26.6 km
X-band Beam-width	–	–	4.0 km to 19.1 km	0.6 km to 7.6 km	3.5 km to 16.6 km	0.5 km to 6.3 km

Table 2 MEO Beamwidth Results

	6.1m		11.3m		13m	
	On Horizon	Direct Over-flight	On Horizon	Direct Over-flight	On Horizon	Direct Over-flight
S-band Beam-width	732.2 km	576.8 km	390.1 km	311.1 km	339.3 km	270.6 km
X-band Beam-width	–	–	97.5 km	77.8 km	84.6 km	67.4 km

Table 3 GEO Beamwidth Results

	6.1m		11.3m		13m	
	On Horizon	Direct Over-flight	On Horizon	Direct Over-flight	On Horizon	Direct Over-flight
S-band Beam-width	1,168.9 km	1,014.4 km	630.5 km	547.1 km	548.4 km	475.9 km
X-band Beam-width	–	–	157.6 km	136.8 km	136.7 km	118.7 km

Table 4 Lunar Beamwidth Results

	6.1m		11.3m		13m	
	Beam-width	Lunar Surface Cov.	Beam-width	Lunar Surface Cov.	Beam-width	Lunar Surface Cov.
S-band Beam-width	–	–	5,112.0 km	100%	–	–
X-band Beam-width	1,354.6 km	39.0%	1,274.7 km	36.7%	–	–
Ka-band Beam-width	–	–	–	–	285.1 km	8.2%

Based on antenna beam width analysis as shown in these Tables, given the basic MSPA support requirement that all spacecraft must be within the

beamwidth of the requested station, the types of NASA missions suitable for NEN MSPA support are discussed in Table 5.

Table 5 Types of Mission Suitable for NEN MSPA Support

Orbit	Suitable Mission Types
LEO	Immediately post-deployment. Super tight trains or clusters, very small fractionated groups.
MEO	Conjunctions for small periods of time give more options (Possibly between separate missions with similar orbits). All formations feasible on small scale, except a constellation.
GEO	Support multiple geosynchronous spacecraft at once. Conjunctions slow or permanent, creating long windows of opportunity.
Lunar	Entire Moon and Low Lunar Orbit fits in the beam width at S band (All formations, including full constellations, are feasible. Can fit any number of craft, frequency allocation permitting). X band needs to be targeted more specifically.

Demonstration of MSPA at Wallops Station

A proof-of-concepts demonstration is being planned at NASA GSFC WFF station to show feasibility of the MSPA technique to support multiple spacecraft simultaneously with an existing antenna. Phase I will focus on traditional MSPA and OMSPA downlink telemetry and Phase II will include OMSPA uplink command and tracking services. The demonstration is an important milestone toward an operational MSPA system at NEN stations.

Analysis will be performed to explore NASA on-orbit spacecraft in LEO and/or Lunar orbit for suitability to support the MSPA demonstration. The goal is to select an opportunistic mission, such as a constellation mission containing multiple spacecraft with the spacecraft’s trajectory being within the beam width of a “host” spacecraft’s ground station antenna.

During Phase I, the demonstration will be performed using downlinks from at least two on-orbit spacecraft. One will be considered the host and the other(s) will be considered secondary spacecraft. Analysis will be performed to accurately identify the intervals of time when opportunities for MSPA exist.

For tradition MSPA, assuming only two spacecraft within the same beam width of the antenna at a time, two applicable receivers will be assigned to the antenna. As the uplink equipment can support only one signal at a time, the command uplink and ranging will be shared between the two spacecraft via time multiplexing. The downlinks for telemetry and ranging will be simultaneously supported with two receivers.

For OMSPA, the spacecraft that will be within the same beam width of the antenna can opportunistically transmit open loop. The signals will be captured on a wide band recorder. The recorded data will be played back to a secure server at Wallops. The appropriate

time and frequency portion of the recorded data is retrieved later for further processing with a software tool that accomplishes demodulation, decoding, and frame processing. The NEN does not currently have the software tool necessary to complete this function. JPL has developed the necessary tool and has committed to supporting the recorded data processing via a secure Internet site. Today, the JPL software tool is still in experimental mode and will be downloadable to a NEN site when it becomes operationally ready.

The objectives of the demonstration are:

1. Investigate MSPA approach: traditional MSPA vs OMSPA.
2. Perform proof-of-concept demonstration to show that traditional MSPA and OMSPA are operationally viable techniques for NEN to support multiple spacecraft simultaneously per station antenna.
3. Investigate NEN MSPA support requirements
4. Perform coverage and link analysis to explore NASA on-orbit spacecraft in LEO and/or Lunar orbit for suitability to support the MSPA demonstration; identify potential missions for NEN MSPA demonstration.
5. Based on STK tool analysis, accurately determine the intervals of time when the missions' spacecraft can do downlink telemetry data simultaneously to the NEN station and schedule the downlink time accordingly.
6. Perform an autonomous traditional MSPA support which is driven by the tracking schedule.
7. Retrieve the recorded telemetry data in the wide band recorder via a secure server and send it to JPL over the Internet for demodulation, decoding, and frame processing with the OMSPA software demodulator.
8. Validate results of the data from the assigned receivers for the traditional MSPA and those data produced by the OMSPA software demodulator/decoder by comparing the transfer frame with those from the mission project
9. Coordinate with GSFC WFF, JPL, and flight missions for demonstration support.

Future efforts after the demonstration will focus on Phase II to include uplink command and tracking in the

next OMSPA demonstration. The final goal is to add MSPA service to NEN stations.

JPL has demonstrated OMSPA successfully. As indicated in their final report, at least 99.95 percent of the transfer frames were successfully recovered from each demonstration recording. It is expected that the MSPA demonstration at GSFC WFF will be successful.

GROUND BASED PHASED ARRAY

The NEN is currently investigating partnerships with industry and universities to conduct future demonstrations of GPBA technology. Similar to MSPA technology, GBPA could afford the NEN the ability to support multiple spacecraft simultaneously from a single system. The goal of a future demonstration would be to develop a GBPA that is equivalent to at least a 6-meter antenna and capable of supporting five to six satellites simultaneously. Future demonstrations can begin to investigate a comparison between a GBPA and the traditional multiple aperture approach in the areas of performance, capability, cost, and operations.

NASA NEN has previously supported a Ball Aerospace and United States Air Force demonstration of a geodesic dome phased array antenna (GDPAA) at the NASA GSFC WFF back in 2004.⁴ During the demonstration six opportunities were presented to support multiple contacts to various vehicles and the boresite tower. The GDPAA steered four independent beams, two of which were transmitting and two which were receiving. Key features of the GDPAA antenna include:

1. Up to four contacts (8 beams) per antenna
2. Electronic scan
3. Built-in multi-band capability (L- & S-band)
4. Gain-on-demand for rapid anomaly resolution
5. Programmable
6. Low O&M cost: no mechanical movement

The GDPAA demonstrations proved the system was capable of supporting multiple targets simultaneously with significant performance. However, the technology at the time was considered expensive when compared with the cost of multiple traditional antennas. Recent advancements in technology development (e.g., FPGA beam former, software defined radios, high power workstation for beam former and transmitter/receiver implementation) and lower COTS equipment costs could show GBPAs are more favorable in cost compared to multiple traditional antennas. While there

has been a large gap in time since the last GBPA demo at NASA GSFC WFF, the NEN is investigating opportunities to restart GPBA demonstrations.

GROUND BASED APERTURE ARRAY

ATLAS Space Operations, Inc. has designed a mobile, rapidly deployable, electronically steered aperture array RF antenna system for satellite communications applications, see Figure 4. ATLAS LINKS array technology consists of an array of receivers, each with multiple antennas, that can receive signals from multiple sources across the entire sky without requiring moving parts or phase shift hardware. In an aperture array, phase shifts and gain changes due to spatial effects are compensated for in software. When configured as an array, the ATLAS LINKS system has the ability to process multiple satellite signals simultaneously. The array has overlapping views of the entire sky which are then combined using spatial filters to reconstruct a signal as if the array were electrically pointed at a target. The number of digitally formed beams depends upon the computing power rather than the number of antennas and phase shift hardware. It is the algorithm combination of phase and gain diversity that distinguish an aperture array from a phase array, where the former has the potential to match the performance of parabolic dish antennas. The lack of moving parts and the ease of assembly gives LINKS antenna array a distinctive advantage over large dish antennas. Commercial off-the-shelf components were used for its manufacture, which makes it highly cost competitive as well.



Figure 4 ATLAS Ground Based Aperture Array

As shown in Figure 5, each antenna unit consists of log-periodic antennas, software defined radios, and a down converter for processing of higher frequency signals. A four-antenna unit along with a CPU/GPU box with power and USB cables makes up one element. Mechanically, the arrangement is compact, enabling whole sky coverage from a man-portable unit. The design follows the computing-at-the-edge paradigm by combining the signals from all four antennas into a single output stream that is then fed as digital data to the next 4-antenna element. Each element holds its own schedule and can record satellite passes even if the network is down.

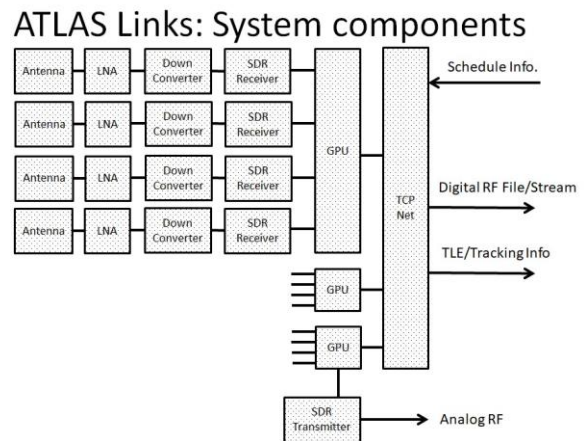

Figure 5 ATLAS LINKS Single Element System Components

A two-radio system was tested at the NASA Goddard Compatibility Test Lab in early 2018. Signal strength and noise levels were varied to emulate a wide range of satellite/ground ranges and geometries. The Bit Error Rate (BER) and Eb/N0 of the LINKS array was compared to that of the original signals, as shown in Figure 6.

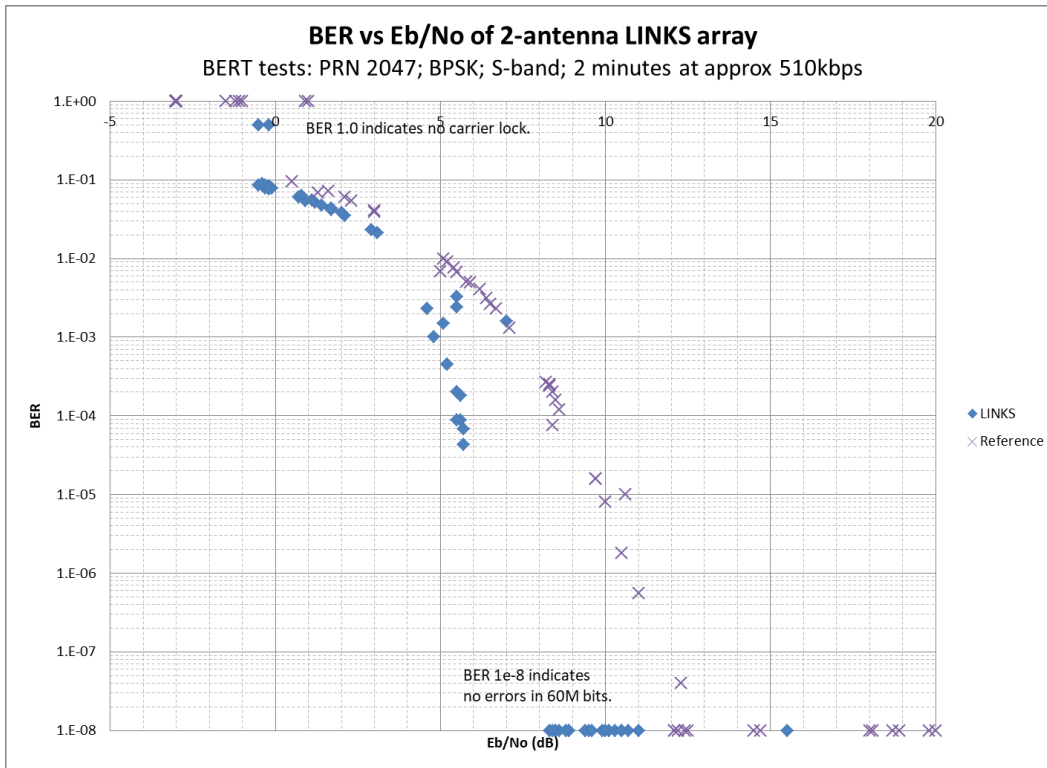

Figure 6 BER vs Eb/No chart of ATLAS LINKS for S-band Coded Downlink

The input signals, shown as diamonds and X's, adhere well to the theoretical BPSK BER curve. However, LINKS shows a different curve as opposed to the theoretical BER vs Eb/No curve for BPSK signals. LINKS achieve perfect BER with 4dB lower Eb/No (a nominal value of 1×10^{-8} is chosen for plotting purposes). LINKS is an aperture array, being unlike a phased array in that it brings not only phase but also gain information to the combining process and accounts for the improvement over a phased array.

ATLAS performed a demonstration at NASA GSFC WFF in April 2018 with a four-element (16 radio) array, where it successfully downlinked satellite passes from four representative satellites (see Figure 7). The sky was sampled with and without satellites during day and night, and work is in progress to calculate a traditional G/T measurement. Predicted G/T values for the tested array are shown in Figure 8.



Figure 7 ATLAS LINKS Array Demonstration at NASA Wallops Flight Facility

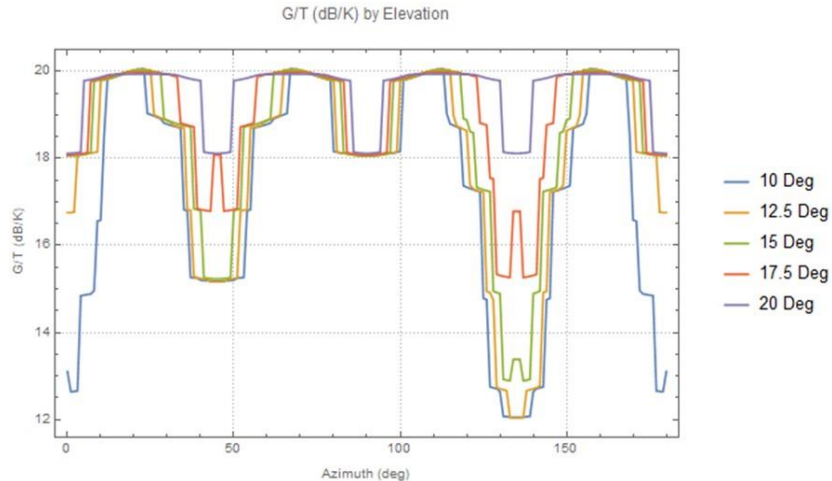

Figure 8 Predicted G/T values of ATLAS LINKS

GROUND-BASED ANTENNA ARRAYING

In Ground-based Antenna Arraying separate antennas capture different parts/frequency or time domains of the downlinked message. The challenge is how to re-assemble the message using different signal processing schemes. This can be accomplished by a variety of techniques: full spectrum combining (FSC), baseband combining (BC), symbol stream combining (SSC), complex-symbol combining (CSC) or carrier arraying (CA). With FSC, the phase and delay from multiple ground antennas has to be controlled and may be filtered before the signals can be combined. CSC uses Open Loop Carrier tracking, and it is by demodulating the subcarriers that the symbol synchronization is achieved before the streams reach the Symbol Combiner. In contrast, SSC requires locked tracking loops, and each datastream is delayed in a controlled manner compared to the other(s) in order to maintain time synchronization. For applications where a subcarrier is used, the harmonics of the subcarrier are used, and the baseband signal is weighted and combined (BC). The signal in this case from each antenna is carrier locked. In Carrier Arraying (CA) a global estimate of the optimal carrier synchronization is calculated by a central location, and this carrier-lock information has to be transmitted back to each antenna. Each technique has different requirements on the instrument, signal strength and antennas, and these will determine the optimal choice(s).

As an example, the DSN used FSC to increase the science data return from the Galileo mission. Another

test was conducted with the Cassini spacecraft, during which a 6 dB relative gain was measured through combining three 34-m antennas.^{5,6}

NEN High Rate Antenna Arraying

NEN is developing a new arraying system but based upon an approach that has been used many times previously: the coherent combination of signals derived from multiple directive antennas. The Deep Space Network (DSN), the Very Large Array (VLA) and Search for Extraterrestrial Intelligence (SETI) all exploit this classic principle. NEN differs in that it is taking advantage of some significant advances in digital hardware that will allow us to achieve coherent combining at data rates more than an order of magnitude greater than before. The cost of constructing and maintaining an antenna does not vary linearly with aperture size. The cost rises dramatically as antenna size increases. Coherent combining of signals from a number of small antennas can easily outperform a single large aperture antenna not only in radio-frequency performance but also in a substantial reduction of cost. There are other considerations as well. Since this is an improvement achieved solely on the ground, NEN will be able to increase their support for a variety of ongoing missions as well as those currently in planning. These range from CubeSats in relative low-altitude LEO orbit to missions at Cislunar orbits. The ability to provide more science data utilizing existing assets is always highly desirable with immediate benefits to both NEN and SCA/N.

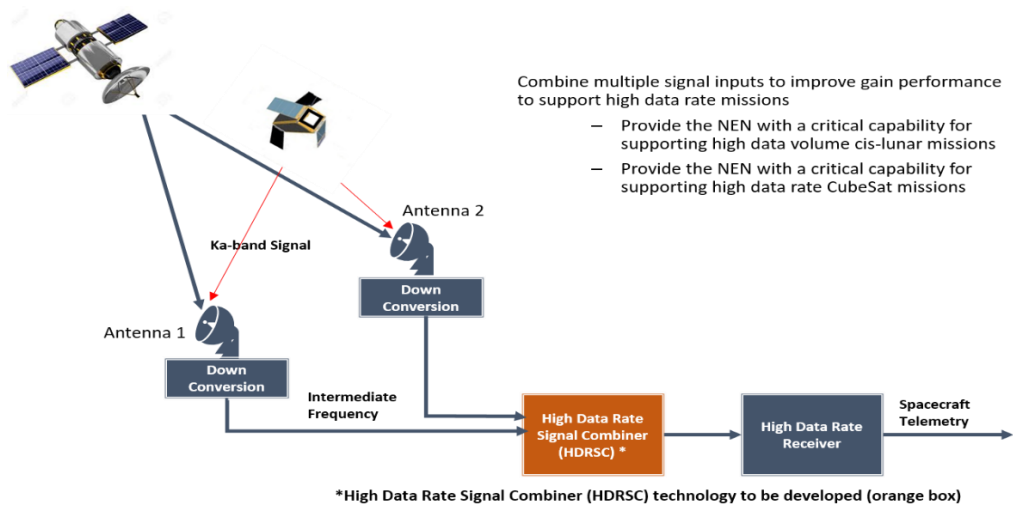

Figure 9 Antenna Arraying - High-Speed Signal Combiner (HSSC)

The high-speed arraying system under development (Figure 9) can be deployed to any ground site that currently has multiple antennas, thereby instantly increasing capability.

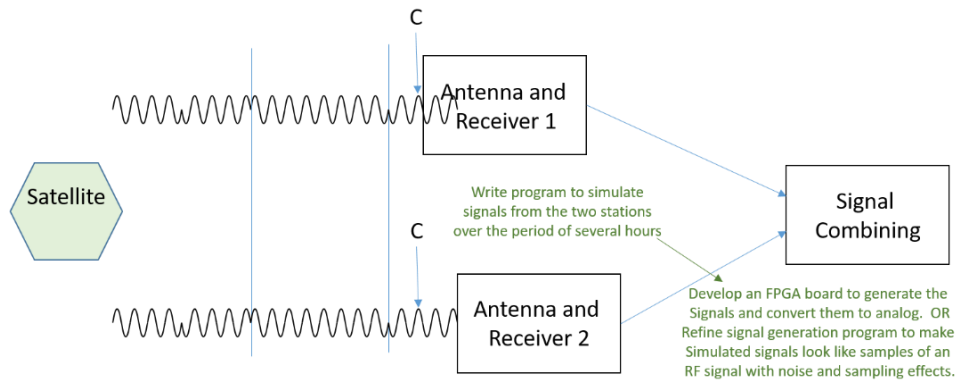

Figure 10 Signal Combining

When coherently combining just two signals there is ideally a doubling of power, I.e., a 3dB signal-to-noise improvement. As shown in Figure 10, RF cycle C is received at one station before the other. In order to do the signal combining, the signal from Receiver 1 must be delayed prior to combining the two signals. For a moving spacecraft the delay will vary continuously but monotonically.

A good example is having a spacecraft at Cislunar orbit transmitting Ka signal at 600 Mbps coming down to two 18-m antennas with an EIRP = to a 300 Mbps level, and an IF output from each antenna going into the arraying High-Speed Signal Combiner (HSSC). Result will be ~ 3 dB arraying gain to produce an output of 600 Mbps.

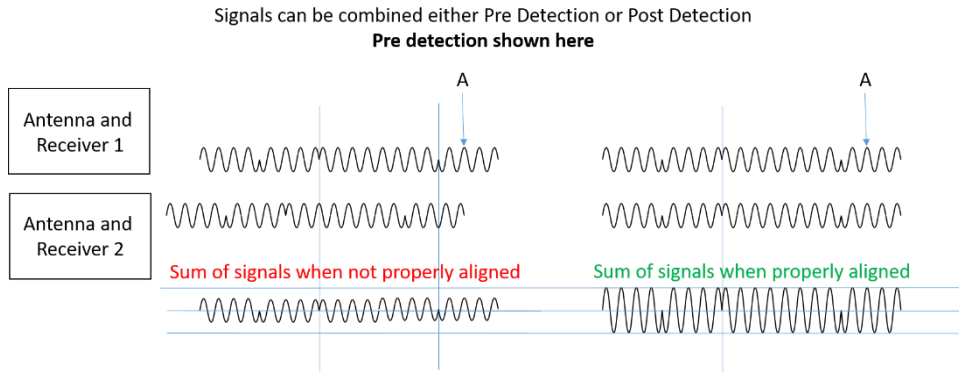

Figure 11 Pre-detection Signal Combining

Figure 12 demonstrates the effects of coherent combination of the received signals in pre-detection combining. With a real signal with noise, the distinction between properly aligned and not properly aligned is not simple. The correlation process is carefully planned. Using an approximate known delay between the stations, a correlation peak will be used to find proper alignment.

High-Speed Signal Combiner Studies and Concept Development

This arraying system was first studied and modeled using MATLAB/Simulink. As shown on the high-level block diagram (Figure 12), the Matlab/Simulink model is used as a basis for building the prototype processor – with a test source representing the spacecraft and channel impediments.

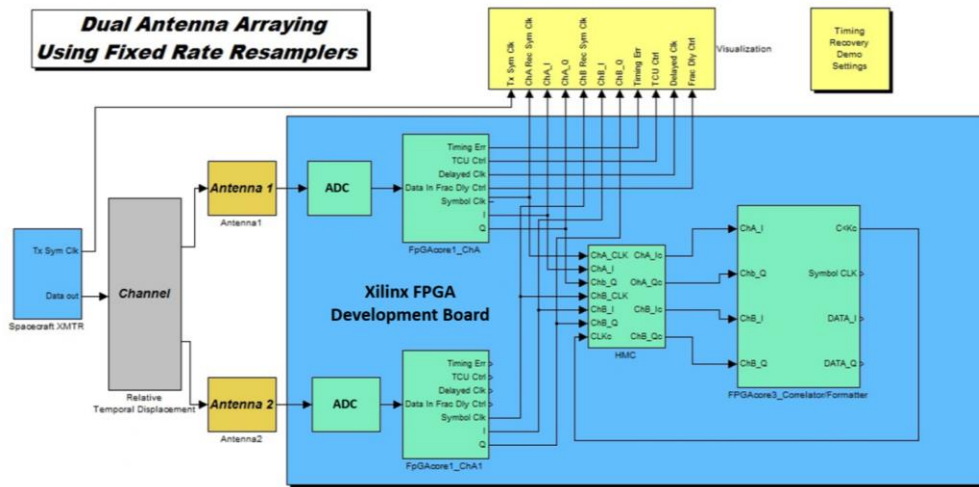

Figure 12 NEN Arraying MATLAB/Simulink Model

The model in Figure 12 shows only high-level details. There are other layers of details contained in the field-programmable gate array (FPGA) primary cores that define this model: the Channels A and B carrier and phase recovery cores, the correlator core, the output formatter core, and clock & timing recovery. Each core serves to generate the VHDL code needed to embed on the Xilinx development board. The spacecraft model already incorporates both carrier and phase instabilities. Similarly, the channel model provides for the relative

temporal displacement (both positive and negative) between the spacecraft and pair of antennas as well for the injection of uncorrelated AWGN noise.

After the concept in Figure 12 was successfully simulated, hardware development continued that includes a high-performance computer, Xilinx FPGA board, 10-bit ADCs, 10-bit DACs, high sample rate (5Gsp/s) connection between the RF frontend ADCs and the DACs, and high-speed interface between the ADCs

and FPGA board. The external interfaces include the dual IF/RF input and output, external 10MHz reference, and external timecode connectors. External 10MHz reference and external timecode are requirements for any instruments intended for installation at an operational ground facility

Target data rate in this design is 600 Mbps or greater for Cislunar missions and in Gbps for LEO missions. Other considerations in the design include the distance between the antennas to be arrayed and the existing hardware interfaces or upgrades required before arraying. The data rate and RF frequency will be coherent via the transmitter design. The IF will be coherent with the RF via the down converter design. The sampling will be coherent with the data via the receiver design. With a data aided circuit in the FPGA, the samples will be positioned to be within the bits, not on the bit transition. Once the delay offset is known, the samples for each phase unit will be added to achieve the arraying gain.

NANO-SATELLITES BEYOND LOW EARTH ORBIT- AND RELEVANCE TO NEN

With the advent of the recent launch of the twin 6U Mars Cube One (MarCO) interplanetary nano-satellites, the era of using this form factor in missions beyond LEO has begun in earnest.^{7,8} Though in closer proximity to cis-lunar space, these will be followed by a volley of 13 EM-1 (Exploration Mission 1) 6U nanosatellites on the forthcoming initial flight of the SLS-1 (Space Launch System -1) flight in early 2020. There is general attraction of the form-factor in that a) it would seem a logical extension to the heavy utilization currently seen in LEO, b) there is an attractive modularity of augmenting science missions, c) the modularity and relatively simple interfaces makes interplanetary space more ‘accessible’ to a wider number of science/technical development teams.

Despite the interest, there are some key challenges which remain – and are dependent on the mission architecture ‘topology.’ The challenges have much to do with the accommodation of a useful communications link at these lunar and Mars distances – and the related electrical power requirements in order to adequately power the radios. As an example, the MarCO X-band transceivers (IRIS) require 35 W input for 3.8 W RF output.⁹ This, coupled with the attitude control for pointing the antenna, makes it challenging to ‘close the design’ in the small 6U volume and yet retain useful science instruments.

In all of the mission cases, it would appear to be prudent to use the NEN capabilities (nominally to 2×10^6 km from the Earth) for either a) testing the nano-satellite communication subsystems prior to a commitment of a major mission launch, or b) direct communication to the Earth where applicable. At present, none of the nano-satellites have seen evolutionary testing in the LEO environment prior to the substantial commitment of performing mission operations at the prescribed long distances. In cis-lunar space the NEN offers an important back-up to the heavily subscribed DSN (Deep Space Network) capabilities.

In order to make better use of the NEN for evolutionary advancement, key (and relatively inexpensive) tests and demonstrations can occur first in LEO. As an example, this is the case of the TechEdSat-8 and successor nano-satellites which are designed as test-beds for critical communication and other technologies. The TechEdSat-8, intended for flight in late 2018, has critical elements of the EM-1 Miles Space payload S-band radio. Early demonstration of the 5W RF communication link will give confidence to controlling the major risk element of the particular EM-1 mission. In addition, it will provide an important demonstration of the vastly improved data volume that can be acquired simply by using the NEN assets. This may be viewed as a precursor to many such nano-satellites in LEO or in cis-lunar space.



Figure 13 TechEdSat-8 is a linear-6U Flight Demonstration Platform (Modulated Exo-Brake Drag Device) for Advancing Telemetry Experiments

CONCLUSION

NEN consists of tracking stations distributed around the globe that are strategically located to maximize the coverage provided to a variety of missions using NEN-compatible radios and operating in LEO, GEO, HEO, lunar, L1/L2 orbits and beyond. This paper presented the results of NEN investigations into the cutting-edge ground-based communications service offerings in

response to addressing unique current and future SmallSat needs.

NASA NEN has been collaborating with universities, government agencies and commercial companies to better understand the characteristics and requirements of different mission sets including SmallSat constellations. These mission requirements will be paving evolution of NEN service offerings that will provide effective and efficient support that can also enable a reduction in network loading and provide cost savings to customers. NEN has been investigating and researching whether new service offerings such as MSPA, GBPA antennas, ground-based antenna arraying, and other emerging capabilities could technically and cost-effectively support and benefit these SmallSat missions. Demonstration of these technologies are being performed and planned. In addition to these research activities, NEN is also investigating streamlining mission planning, integration, and compatibility test options for low budget and compressed schedule SmallSat missions and is evaluating cost-effective NEN-compatible radio options.

In summary, this paper presented results from the NEN's investigations into the increased trend of the current and future SmallSat and SmallSat formation flying missions. The paper discussed the benefits of MSPA, GBPA antennas, and ground-based antenna arraying. Also, potential implementation options for future demonstrations at the NASA NEN WFF were presented.

Acknowledgments

The authors wish to thank the NASA NEN and GSFC for funding investigations for improved space communications support for the Small Satellite community.

References

1. S. Schaire, S. Bundick, C. Roberts, L. Ambrose, J. Mason, S. Altunc, M. Lamberson, J. Baros, P. Celeste, P. Perrotto, M. Bollard, "Streamlining Ground Station Network Compatibility Test for Small Satellites" Proceedings of the 15th Annual Conference on Space Operations, Marseille, France, May, 2018.
2. Performance Analysis of a NASA Integrated Network Array, James A. Nessel, Glenn Research Center, Cleveland, Ohio, NASA/TM, 2012-217112.
3. Next-Generation Ground Network Architecture for Communications and Tracking of

Interplanetary Smallsats, Kar-Ming Cheung, et al, IPN Progress Report 42-202, August 15, 2015

4. H. Moore, "Geodesic Dome Phased Array Antenna (GDPA): An AFSCN Upgrade Option" Presentation at GSFC WFF, March 2, 2010.
5. Future Plans for the Deep Space Network (DSN) - September 1, 2009, Barry Geldzahler and Les Deutsch, JPL.
6. Antenna Arraying Techniques in the Deep Space Network, D. Rogstad, A. Mileant, T. Pham, JPL, 2003.
7. A. Klesh, J. Krajewski, "MarCO: Mars Cube One – Lessons Learned from Readyng the First Interplanetary Cubesats for Flight," 49th LPSC (Lunar and Planetary Science Conference) 2018 (LPI Contribution No. 2083), paper: 2923.pdf, The Woodlands, Texas, March 19–23, 2018.
8. Andrew Klesh, Joel Krajewski, "MarCO: CubeSats to Mars in 2016, Proceedings of the 29th Annual AIAA/USU Conference on Small Satellites, Logan, Utah, USA, August 8-13, 2015, paper: SSC15-III-3.
9. National Aeronautics and Space Administration Jet Propulsion Laboratory, "Iris V2.1 CubeSat Deep Space Transponder", JPL 400-1604, Initial Release, 2016