

National Aeronautics and
Space Administration

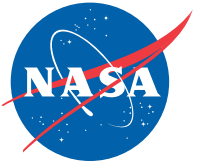

NASA/TM-2018-219958

Marshall Space Flight Center
RESEARCH AND TECHNOLOGY REPORT
2017

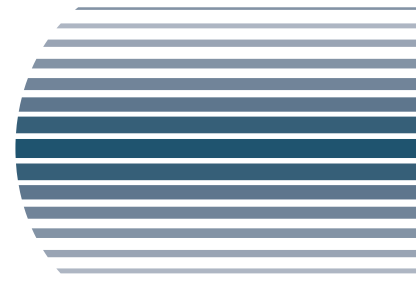

Marshall Space Flight Center
Research and Technology Report 2017

*A.S. Keys and H.C. Morris, Compilers
Marshall Space Flight Center, Huntsville, Alabama*

ACKNOWLEDGMENTS

The points of contact and coordinator at Marshall Space Flight Center (MSFC) for this Technical Memorandum (TM) are Andrew Keys (256-544-8038) and Heather Morris. The MSFC Office of Center Chief Technologist recognizes Janice Robinson, NiCarla Friend, and Kathy Jobczynski of the MSFC Scientific and Technical Information Group for assisting in the development of this report. The Former Center Chief Technologist Andrew Keys and Technologist Heather Morris provided the support, knowledge, insight, and decisions needed for the compilation of this TM.

TRADEMARKS

Trade names and trademarks are used in this report for identification only. This usage does not constitute an official endorsement, either expressed or implied, by the National Aeronautics and Space Administration.

For additional copies of this report contact:

NASA STI Information Desk
Mail Stop 148
NASA Langley Research Center
Hampton, VA 23681-2199, USA
757-864-9658

This report is available in electronic form at
<<http://www.sti.nasa.gov>>



FOREWORD

Marshall Space Flight Center is essential to human space exploration and our work is a catalyst for ongoing technological development. As we address the challenges facing human deep space exploration, we advance new technologies and applications here on Earth, expand scientific knowledge and discovery, create new economic opportunities, and continue to lead global space exploration.

Our investments in technology not only support NASA's current missions, but also enable new missions and scientific pursuits. Some of these projects will lead to a sustainable in-space architecture for human space exploration, such as developing and testing cutting-edge propulsion solutions for spacecraft and landers for the journey to Mars. Others are working on technologies that could support deep space habitats, which will enable humans to safely live and work in deep space and on the surface of Mars and other destinations across the solar system. Still others are developing new scientific instruments capable of providing an unprecedented glimpse into the early universe.

Our work is driven by the greater purpose of scientific progress and discovery.

While each project in this report seeks to advance new technology and challenge orthodoxies, it is important to recognize the diversity of activities supporting our mission. This report underscores the Center's capabilities and highlights the progress achieved over this past year. These scientists, researchers and innovators are why NASA will continue to be a world leader in innovation, exploration, and discovery for years to come.

I hope you enjoy reviewing this report. It has been an exciting year and has set the stage for even more progress in 2018.

Todd A. May
Director
Marshall Space Flight Center

INTRODUCTION

I am pleased to present to you this copy of the Marshall Space Flight Center Research and Technology Report 2017. Each year, the annual Research and Technology report is published with the purpose of highlighting the most novel and innovative work being accomplished by the scientists, engineers and technologists of NASA's Marshall Space Flight Center.

This report features over 60 technology development and scientific research efforts that collectively aim to enable new capabilities in spaceflight, expand the reach of human exploration, and reveal new knowledge about the universe in which we live. These efforts include a wide array of strategic developments: launch propulsion technologies that facilitate more reliable, routine, and cost effective access to space; in-space propulsion developments that provide new solutions to space transportation requirements; autonomous systems designed to increase our utilization of robotics to accomplish critical missions; life support technologies that target our ability to implement closed-loop environmental resource utilization; science instruments that enable terrestrial, solar, planetary and deep space observations and discovery; and manufacturing technologies that will change the way we fabricate everything from rocket engines to in situ generated fuel and consumables.

I trust that you will enjoy reviewing these research and technology accomplishments of 2017. May this report serve as inspiration for further innovations into 2018 and beyond.

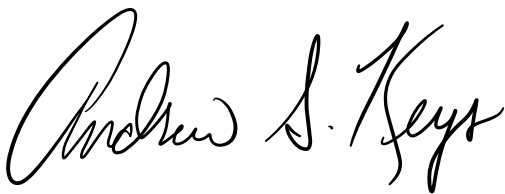

Andrew S. Keys, Ph.D.

Chief, Optics and Imaging Branch



TABLE OF CONTENTS

Propulsion Systems	1
Integrated Oxygen-Rich Test Article (IOTA)	2
Advanced Booster: Hydroxyl-Terminated Polyether (HTPE) Propellant Liner Insulation (PLI) System Development.....	4
Development of Floating Slosh Dampers for Propellant Tanks	6
Near Earth Asteroid Scout.....	8
Deep Space Engine.....	10
Technology Development of the Mars Ascent Vehicle Hybrid Fuel Grain.....	12
Fabrication and Characterization of a Grooved-Ring Fuel Element for a Nuclear Thermal Rocket.....	14
Pulsed Fission-Fusion (PuFF) Target Design and Containment System.....	16
Multiscale Nuclear Thermal Propulsion (NTP) Nuclear Fuel Material Simulation	18
Electric Sail Tether Deployment System.....	20
Liquid Oxygen (LOX) Expansion Cycle: A Dual Cooled-Expander Cycle Engine Using Hydrogen and Oxygen.....	22
Low-Cost Plasma Micropropulsion Using 3D Printing and Off-the-Shelf Components	24
Multimode Micropropulsion for Small Spacecraft.....	26
Dual-Mode Green Propulsion Proof of Concept: Providing Both Innovative Green Propulsion and Micropropulsion for Small Spacecraft.....	28
Autonomous Systems	31
Smartphone Video Guidance Sensor-Based Navigation of RINGS Onboard the International Space Station	32
Habitat Ground-Based Demonstrator: Auto-Operator for the Autonomous Fluid Transfer System (AFTS).....	34
Communication and Navigation	37
Programmable Ultra Lightweight System Adaptable Radio (PULSAR).....	38
Mars Ascent Navigation.....	40
Life Support and Environmental Monitoring	43
Ionic Liquids (ILs) Enabling Revolutionary Closed-Loop Life Support.....	44
Series-Bosch Oxygen Recovery Mix and Match Evaluations	46

In Situ Resource Utilization	49
In Situ Production of Cementitious Material from Martian Resources.....	50
Purification of Lunar Cold-Trapped Volatiles	52
Ionic Liquid (IL) Metals and Oxygen Extraction in Microgravity: A Prelude to Asteroid Mining	54
Additive Construction With Mobile Emplacement (ACME).....	56
Science Instruments	59
Advanced Microwave Precipitation Radiometer (AMPR)	60
CLASP2: The Chromospheric Layer Spectropolarimeter	62
Fly’s Eye Geostationary Lightning Mapper Simulator (FEGS).....	64
Fermi Gamma-Ray Burst Monitor (GBM)	66
Hinode	68
Hurricane Imaging Radiometer (HIRAD).....	70
Lightning Imaging Sensor (LIS).....	72
Lynx X-Ray Observatory Concept Study	74
Objective Estimation of Tropical Cyclone Intensity	76
Testing and Calibration of the Parker Solar Probe Mission SWEAP Solar Probe Cup	78
Snap-IMS: A Snapshot Hyperspectral Imager for Earth Remote Sensing	80
Advanced UVOIR Mirror Technology Development for Very Large Space Telescopes.....	82
The Imaging X-Ray Polarimetry Explorer (IXPE).....	84
Next-Generation Lightning Instrument Package (LIP) via Merged Sensor and Data Technologies.....	86
Predictive Thermal Control Technology for Stable Telescopes	88
Modeling and Information Technology	90
Immersive Decision-Making Environment (IDME) for Mission-Driven Technology Alignment (MDTA)	92
Cloud-Based App Design (AVAIL).....	94
Short-Term Prediction Research and Transition (SPoRT)	96

Manufacturing	99
Embedded Wireless Strain Sensors for Rapid Characterization of Structural Health	100
In-Space Recycling and Reuse: Refabricator and Erasmus Technologies.....	102
In-Space Manufacturing (ISM) Multimaterial Fabrication Laboratory (FabLab).....	104
Toward In-Space Additive Manufacturing of Thermosets With Embedded Fibers.....	106
3D Printed Electroluminescent Light Panels	108
Ionic Polyimides: New High-Performance Polymers for Additive Manufacturing	110
Space Environmental Effects on Additively Manufactured Parts	112
Void Optimization Laser-Ultrasonic Additive Manufacturing Test Utility System (VOLATUS).....	114
Additive Manufacturing Cleaning Process Improvement.....	116
Characterizing Effects of Potential Build Induced Defects in Selective Laser Melting Components	118
Fatigue Behavior of Freeform, Additively Manufactured Inconel 718.....	120
Low Cost Upper Stage-Class Propulsion (LCUSP).....	122
The Fabrication of Lightweight, Full-Shell, Replicated Optics by 3D Printing.....	124
Composite Technology for Exploration (CTE)	126
Thermal Management	129
An Adaptive Time Stepping Approach for Transient Simulations with GFSSP	130
Evolvable Cryogenics Project (eCryo).....	132
Centennial Challenges.....	134



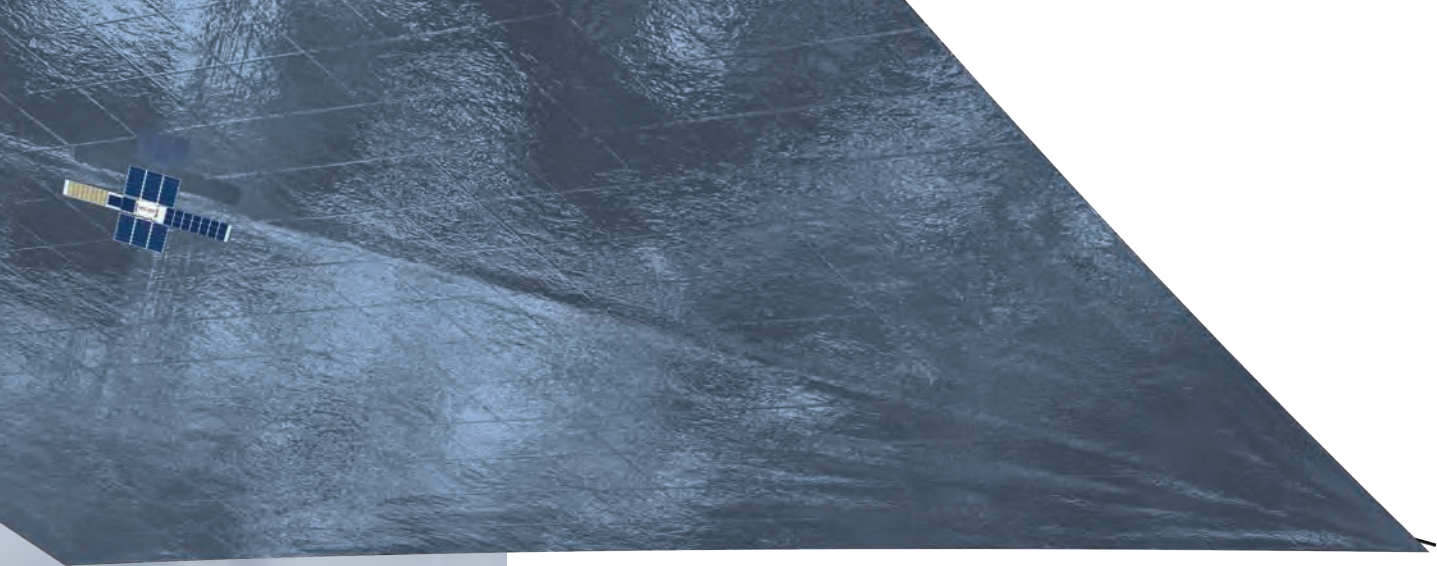

PROPULSION SYSTEMS

Propulsion technologies are a vital part of spaceflight, providing power to escape Earth's gravity, while also maintaining a specific mission trajectory. Therefore, researching and developing conventional and novel propulsion methods is the goal of the first two Technology Areas in the NASA Technology Roadmap. Traditional solid and liquid rocket propulsion systems have been used since the dawn of spaceflight and are comprised of fuel and oxidizers in solid or liquid form. Unconventional launch technologies include systems that do not rely solely on onboard energy for launch or that use unique technologies or propellants to create rocket thrust.

The overall goal of launch propulsion system technologies is to make access to space—specifically low-Earth orbit (LEO)—more reliable, routine, and cost effective. In-space propulsion begins where the launch vehicle upper stage leaves off, performing the functions of primary propulsion, reaction control, station keeping, precision pointing, and orbital maneuvering. Advanced in-space propulsion technologies will enable much more effective exploration of our Solar System and will permit mission designers to plan missions to fly anytime, anywhere, and complete a host of science objectives at the destinations with greater reliability and safety. Ideally, a portfolio of propulsion technologies should be developed to provide optimum solutions for a diverse set of missions and destinations.



Integrated Oxygen-Rich Test Article (IOTA)

OBJECTIVE: To demonstrate stable combustion of a full-scale, oxygen-rich staged combustion test article representation of a hydrocarbon/oxygen booster rocket engine.

PROJECT DESCRIPTION

The Integrated Oxygen-Rich Test Article (IOTA) is a collaborative effort between NASA and the United States Air Force (USAF). Oxygen-rich, staged-combustion booster rocket engines, such as the Russian-made RD-180, offer superior performance attributes as compared to older, previously developed hydrocarbon-based rocket engines. IOTA is intended to demonstrate stable combustion of an oxygen-rich, staged-combustion rocket engine cycle using full-scale components. In this case, full-scale means a thrust level of approximately 500,000 lbf. A rocket engine using this technology could be used for nearly any earth-to-orbit booster for either NASA or USAF applications.

Staged combustion is a power-cycle concept where there are two separate combustion zones within a rocket engine. The first combustion zone—called a preburner—is operated at either a fuel-rich mixture ratio or an oxygen-rich mixture ratio. This off-optimal

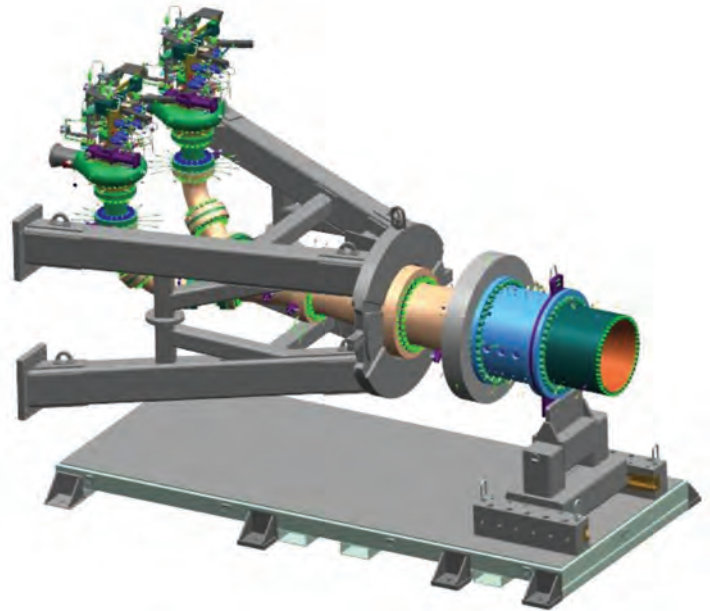

FIGURE 2. Solid model of the assembled IOTA.

combustion generates relatively low-temperature combustion products that are used to drive the engine turbomachinery. Then, these combustion products that contain either excess fuel or excess oxygen are combined with additional propellants combusted again within the thrust chamber assembly so as to generate thrust for the vehicle. Engine cycles with fuel-rich preburners can be useful for hydrogen-based rocket engines. This is what was used for the high-performance Space Shuttle main engine and is still used the RS-25. Engine cycles with oxygen-rich preburners can be useful for hydrocarbon-based engines (either kerosene or methane) to achieve both high performance and combustion stability.

Very high-pressure, hot, oxygen-rich environments represent a considerable technical challenge. In such environments, nearly anything burns, including most metals. IOTA is composed of specially formulated alloys that resist ignition in oxygen-rich environments. Further, as was seen during the development of the Saturn V launch vehicle and the F-1 rocket engines, achieving stable combustion with kerosene (also called RP-1) as the fuel also represents a considerable challenge.

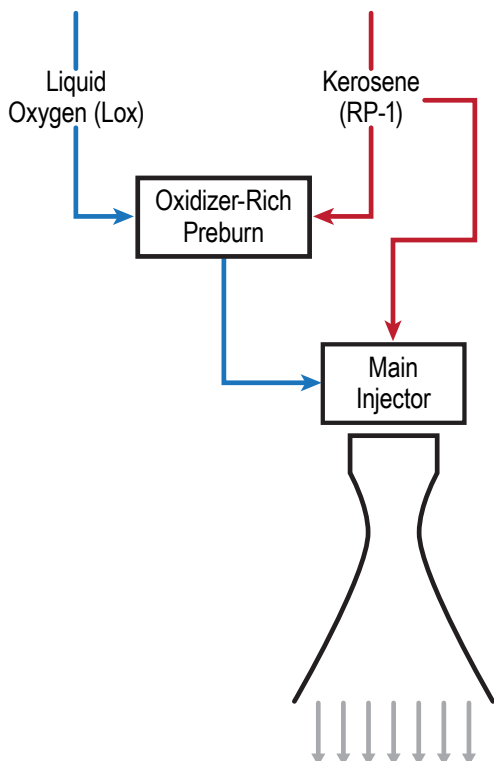

FIGURE 1. Conceptual representation of IOTA.

Both the oxygen-rich preburners and the fuel-rich thrust chamber assembly have been designed to minimize the likelihood of combustion instabilities. A number of separate subscale tests have been conducted to validate the elements of these combustion zone designs.

The IOTA is composed of two oxygen-rich preburners being developed by the Air Force Research Laboratory (AFRL) under the Hydrocarbon Boost (HCB) Program. NASA Marshall Space Flight Center (MSFC) is developing the main thrust chamber assembly under the Advanced Booster Engineering Demonstration and/or Risk Reduction (ABEDRR) contract that was initially associated with the Space Launch System (SLS) Program. Hot-fire testing of the IOTA will be conducted at the NASA Stennis Space Center (SSC) in southern Mississippi.

ACCOMPLISHMENTS

All of the hardware elements of the IOTA have been designed and, by the end of 2017, are either complete or nearly complete with regards to fabrication. Test Stand E1 at NASA SSC has been altered to accommodate the IOTA hardware including the installation of an overhead bridge crane to enable test article assembly.

Detailed assembly planning and test planning are underway. Current schedules show the start of hot-fire testing to be in late 2018. The two oxygen-rich preburners will be tested first and then the entire test



FIGURE 3. NASA SSC Test Stand E1, cell 1.

article, including the thrust chamber assembly, will be tested in the staged combustion configuration.



FIGURE 4. ABEDRR hardware fabrication in work.

SUMMARY

Oxygen-rich staged combustion rocket engines were initially developed by the Soviet Union. Today, such engines are produced in Russia. Harnessing the power and performance of this challenging rocket engine cycle will represent a significant advance in the U.S. booster propulsion technology portfolio. The IOTA effort will demonstrate, at full scale, the combustion elements of the oxygen-rich staged combustion rocket engine. This activity represents an important step forward towards making a complete engine design plausible in the near term. Testing of IOTA elements will begin in 2018 and are expected to continue into 2020.

PROJECT MANAGER: William D. Greene

PARTNERSHIPS: NASA MSFC, USAF Space and Missile Systems Center, AFRL, and NASA SSC

FUNDING ORGANIZATION: USAF Space and Missile Systems

Advanced Booster: Hydroxyl-Terminated Polyether (HTPE) Propellant Liner Insulation (PLI) System Development

OBJECTIVE: To develop and test the hydroxyl-terminated polyether (HTPE) propellant liner insulation (PLI) system in order to reduce the risk of a future design, in the event that the Space Launch System (SLS) Program decides to develop an advanced booster.

PROJECT DESCRIPTION

The propellant liner and insulation (PLI) system has been evaluated as a whole and as individual components through a series of test matrices. Hydroxyl-terminated polyether (HTPE) propellant has been produced at mix sizes up to and including five gallons. HTPE propellant was tested for rheological, mechanical, ballistic, and safety properties. Erosion-resistant liner has been tailored to meet the needs of this HTPE propellant and tested in subscale PLI samples. Insulation materials



FIGURE 1. HTPE at the end of mixing.

have been tested for bonding capability within the PLI system.

Propellant testing was performed to characterize and optimize the propellant processing and performance. Rheological property testing included propellant viscosity, pot life, and working life. Mechanical property testing was accomplished on cured propellant at multiple rates, temperatures, and pressures. Ballistic properties were measured using subscale motors. The pressure and temperature sensitivities were estimated from the test results.

ACCOMPLISHMENTS

HTPE propellant was selected for evaluation due to its combination of high payoff and high risk. HTPE has the potential for significant performance and mechanical property gains. However, this propellant has not been fielded in a large space propulsion system. The production experience with HTPE is limited to smaller systems not requiring multiple mixes per motor. These attributes made this propellant formulation a prime candidate for risk reduction and advancement. The HTPE formulation is an 82.76% solids, high-performance-class 1.3-C propellant.

Testing was performed to characterize the propellant and to optimize processing and performance. The test results demonstrate that the mechanical properties for low temperatures and high-rate loads are extraordinary. The mechanical capability at high temperatures and low rates are not (see figs. 2 and 3). Although the testing performed to date indicate that this formulation may be challenged to meet long-term storage requirements for mechanical properties, it is believed that the data can also be used to retarget the formulation to gain

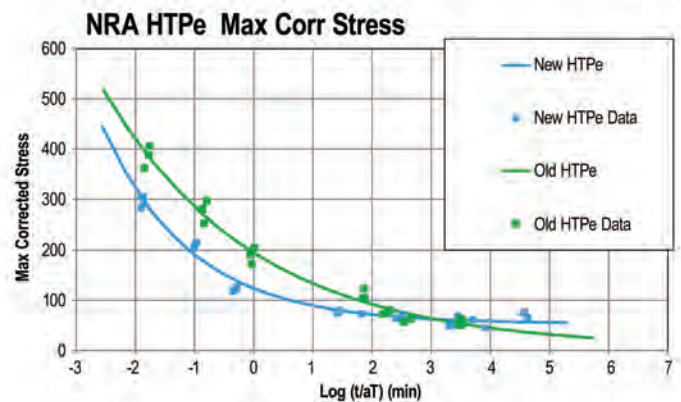

FIGURE 2. HTPE phase I and II comparison: Max stress.

low-rate capabilities at the cost of some of the high-rate capabilities. Mixing procedure and pot life optimization are more important for larger, multiple-mix-campaign programs. Key parameters investigated include end-of-mix viscosity, pot life, and working life.

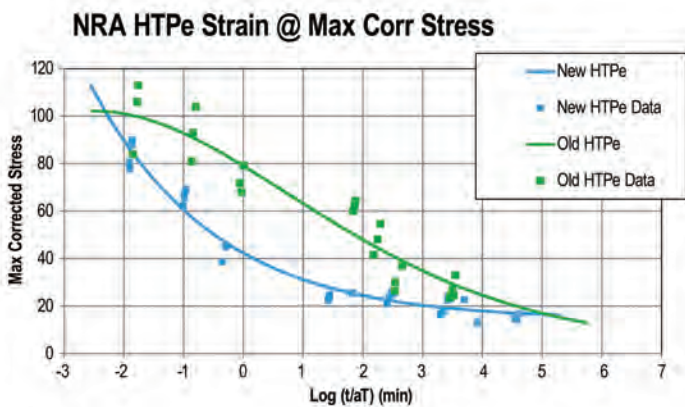

FIGURE 3. HTPe phase I and II comparison: Strain at max stress.

At the system level, several key lessons have been learned through this effort. The most important observation is that higher-energy propellants, with adequate properties for large booster applications, are within our grasp. Although some modifications may be desired to improve tact time and facility capacity, there is no reason to believe that these propellants cannot be produced. HTPe end-of-mix viscosity may be too low and risk settling, so future efforts will investigate increasing viscosity. Pot life is more than adequate for a single mix and can be tailored using a cure catalyst. Working life determination is still under investigation. Current methods appear to accelerate the cure process.

SUMMARY

HTPE testing confirmed the propellant burn rate can be successfully targeted using AP particle size and grind fraction (fig. 4). HTPe propellants’ mechanical properties are very good under cold and high-rate test conditions representing ignition. Additional testing configurations will need to be investigated to confirm performance at slow rate and high temperatures. HTPe pot life can be extremely long, but side reactions from stabilizers tend to reduce mechanical properties. Achieving all necessary large-scale booster propellant properties are possible with HTPe propellants. Future work includes scale up to larger mix sizes as well as testing large subscale motors.

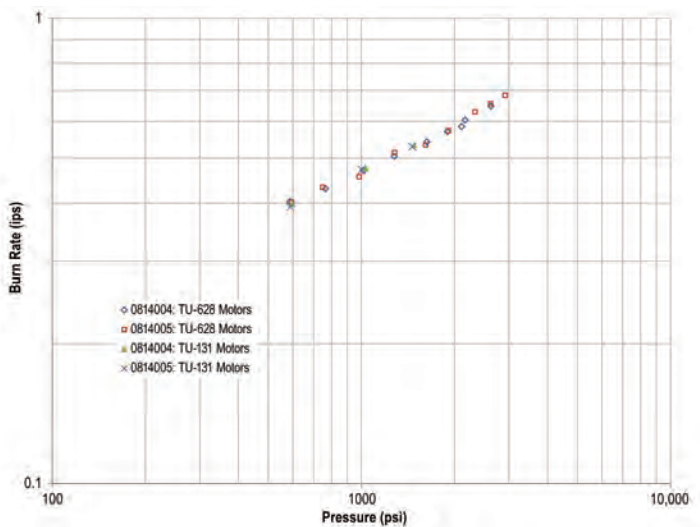

FIGURE 4. HTPe subscale motor burn rate comparison

PROJECT MANAGERS AND/OR PRINCIPAL

INVESTIGATORS: Angie Jackman, Jessica Chaffin, Mignon Thames, Bobby Taylor, and Philip Stefanski (Jacobs ESSSA)

PARTNERSHIP: Orbital-ATK, Brigham City, Utah

FUNDING ORGANIZATION: Space Launch System Development

Development of Floating Slosh Dampers for Propellant Tanks

OBJECTIVE: To characterize and optimize floating dampers consisting of many particles.

PROJECT DESCRIPTION

Propellant slosh can cause loss of control in launch vehicles. Traditionally, slosh is controlled through slosh baffles distributed throughout propellant tanks. Floating baffles have the potential to reduce weight, cost, and complexity of slosh control devices. Floating particles on a fluid's surface has been shown to dissipate fluid slosh, but optimization is needed if this method of slosh control is to be utilized. This project is an effort to determine how to optimally design a damper consisting of floating particles through analysis of previous data, new slosh testing, and evaluation of potential damper materials.

The project involves review of previous test results, analysis of trends and scaling behavior, evaluation of materials appropriate for the application, and new slosh testing to determine the effect of damper weight, density, and particle geometry on damping efficiency. In this year, a review of past slosh tests using floating particles was performed. Results of the review were presented at the Joint Army, Navy, NASA, Air Force (JANNAF) spring meeting. Evaluation of materials which could be used as a floating damper in a wide variety of propellants was conducted using liquid nitrogen and nitric acid as screening fluids. Selected mate-

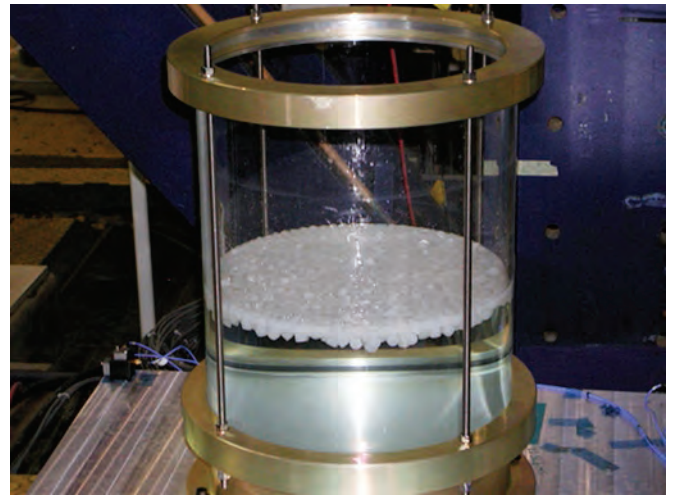
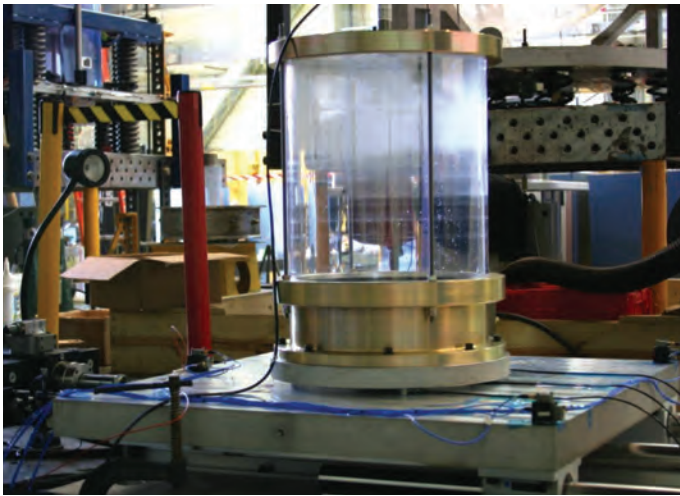

FIGURE 1. On left is the test setup used for some of the data collection. The tank is mounted to a plate instrumented with 3 accelerometers. The plate rides on 3 rails allowing accelerations to be applied to the tank. On right is the tank in a test configuration of fluid and floating particles.

Floating dampers have been tested at times in the aerospace industry and even utilized in the Redstone rocket, but weight and reliability issues have seen fixed dampers become the preferred method. The use of multiple particles has not been employed for such a task, but it may prove to have significant benefits. For instance, the particles are individually too small to make a significant impact on tank walls. Also, design and manufacture of a damper of this sort is trivial.

rial was purchased and cut to the desired particle size for use in slosh tests. New slosh tests to determine the effect of material density on damper effectiveness were deferred to 2018, year 2 of the project, due to facility scheduling issues.

ACCOMPLISHMENTS

The analysis of data indicated the following:

- (1) Floating particles were effective in damping if at least a monolayer of particles was present.
- (2) Once a monolayer of coverage was attained, the addition of more particle mass resulted in increased damping with a response that was slightly greater than linear.
- (3) Spherical particles were less effective than cylindrical particles in terms of the damping obtained per unit of damper mass.
- (4) There was little difference in damping between cylindrical particles with the same radius and differing lengths, but particles with a diameter-to-length ratio around 1 provided better damping. This aspect ratio coincides with condition, where the particles have two stable floating orientations.
- (5) Annular tubes—i.e., hollow cylinders—were more effective dampers than equivalent solid cylinders on a per-mass-unit basis. This indicates that increasing surface area per unit mass will increase the efficiency of the damper.
- (6) Increasing the fluid density by adding salt increased damping. The difference in damping was greater than that from the effect of increased fluid viscosity alone.
- (7) Test data from different-sized tanks indicated that the damping coefficient for similar dampers scaled roughly with the tank radius to the $-3/2$ nd power.
- (8) Data analysis did not show a statistically significant damping from particle friction; viscosity was the overwhelming source of slosh damping.

These results were presented at the spring JANNAF meeting. In addition, expanded polyvinylidene fluoride (PTFE) foam and closed-cell foam polyvinylidene fluoride (PVDF) were identified as a promising material for floating dampers. Samples of these polymers were floated in liquid nitrogen and concentrated nitric acid to screen for chemical and thermal compatibility with various propellants. The former is slightly more robust to chemical attack, while the latter is more appropriate when low surface tension might allow fluid permeation of the cell of an expanded foam. In preparation for slosh testing to occur in the next year, hollow tubing of differing density PVDF was purchased and cut for use in floating dampers.

SUMMARY

Analysis of previously existing data indicated that a floating damper of multiple particles can be effective at slosh damping. Trends observed from differing numbers, sizes, and shapes of particles used in floating dampers were analyzed and reported at the JANNAF spring meeting. Testing showed that materials appropriate for use as floating dampers in a wide range of propellants are readily available. In year 2, the effect of material density and surface area on floating damper efficiency will be investigated through new slosh tests.

PROJECT MANAGERS AND/OR PRINCIPAL INVESTIGATORS: James Patton Downey, Russell Parks, Ravi Purandare.

FUNDING ORGANIZATION: Center Innovation Fund

Near Earth Asteroid Scout

OBJECTIVE: To utilize a solar sail in order to propel a small spacecraft on a 2.5-year mission to explore an asteroid.

PROJECT DESCRIPTION

Before committing a crew to visit a near-Earth asteroid (NEA) or Mars moon, sending precursor robotic reconnaissance mission(s) to assess their suitability for future human exploration is important to do before committing a crew to visit a near-Earth asteroid (NEA) or Mars moon. The NEA Scout, scheduled to launch in 2019, will use its solar sail propulsion system to send a small spacecraft to flyby asteroid 1991VG, obtaining important images and scientific measurements. Solar sails ‘sail’ by reflecting sunlight from a large, lightweight, reflective material that resembles the sails of 17th- and 18th-century ships and modern sailing ships. Similar to how a ship uses the wind to sail, the solar sail derives thrust by reflecting solar photons. While the force exerted by sunlight is extremely small, it is relatively constant, resulting in a slow-but-constant acceleration that pushes the sail—and the spacecraft attached to it—to higher and higher speeds with minimal use of fuel for reaction control. Elements of NEA Scout are being developed at Marshall Space Flight Center (MSFC), Jet Propulsion Laboratory (JPL), and Langley Research Center (LaRC). MSFC manages the mission and is developing the 86-m² solar sail propulsion system onsite.

The NEA Scout spacecraft is housed in a 6U-CubeSat form factor. A CubeSat is a very small spacecraft built on a modular design architecture of 10 × 10 × 10 cm cubes. Each cube is called a ‘U’ and is typically allocated about 2 lb of total mass. A spacecraft can then be built by combining these cubes together.

The innovation is the design, development, and test of a solar sail system that fits within such a small volume and that is capable of providing the propulsion required for the mission. The solar sail will be a single sheet deployed on four booms from the center 2U of the 6U

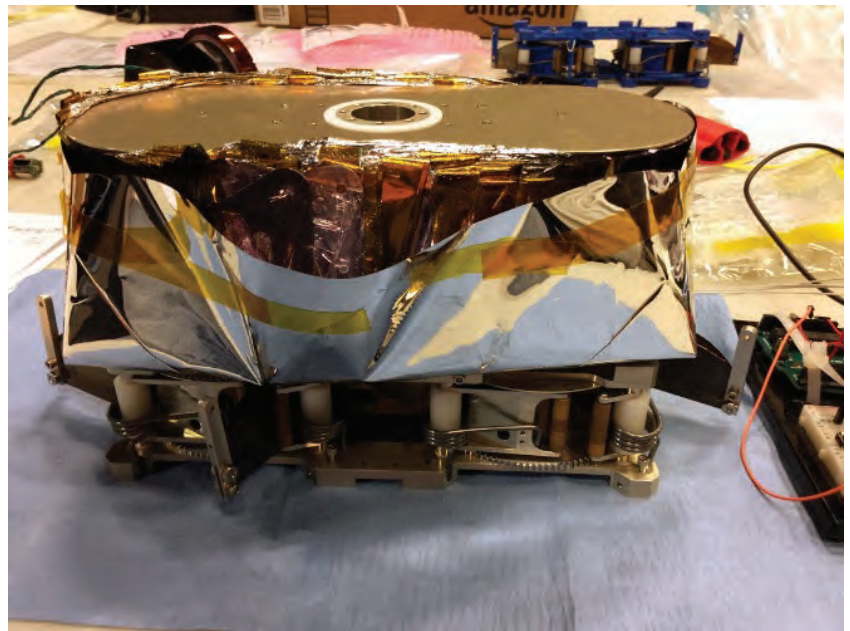

FIGURE 1. The NEA Scout solar sail spooled before deployment.

spacecraft. The solar sail subsystem consists of a single 86-m² colorless polymer (CPI), 2.5-micron-thick aluminumized sail that will sit on top of and be deployed by four Elgiloy (a stainless-steel alloy) booms integrated with an active mass translation (AMT) device to support attitude control of the spacecraft. Key objectives for the year included testing the solar sail and AMT subsystems. These two subsystems will be integrated into the spacecraft next year and delivered to the launch site in 2019.

ACCOMPLISHMENTS

Flight-like engineering development units of the solar sail and AMT subsystems were developed and tested. Both units were manufactured and assembled with flight-like materials and processes. The solar sail deployer used a full-size, 86-m² solar sail and full-length, 6.8-m Elgiloy triangular rollable and collapsible (TRAC) booms. The flight-like sail was subjected to environmental tests including ascent vent, thermal vacuum, and random vibration. The test program culminated in a full-scale sail deployment demonstration test in September 2017.

The AMT was developed to correct for the offset in the center of mass (CM) and center of pressure in the solar sail flight system. Residing near the geometric center of NEA Scout, the AMT adjusts the CM by moving one portion of the flight system relative to the other. The AMT was given limited design space—17 mm of the vehicle's assembly height—and was required to generate $\pm 8 \times 2$ cm translation to submillimeter accuracy. Testing of the flight-like AMT uncovered thermal



FIGURE 2. The partially unfurled NEA Scout solar sail during a deployment test.

issues with the stepper motors required to drive it; mitigations were implemented to correct the problems uncovered. Flight hardware manufacturing has commenced and assembly is to begin in December 2017.

SUMMARY

NEA Scout will demonstrate the feasibility of using a low-cost, solar-sail-propelled CubeSat on an asteroid reconnaissance mission. If successful, it will be America's first interplanetary mission propelled by a solar sail and a pathfinder for many potential missions using sail technology in the future.



FIGURE 3. A relieved test team observing the the fully deployed solar sail.

PROJECT MANAGER AND PRINCIPAL INVESTIGATORS: Erin Betts (PM), Les Johnson (Solar Sail PI), and Julie Castillo-Rogez (Science PI)

PARTNERSHIPS: JPL and LaRC

FUNDING ORGANIZATION: Advanced Exploration Systems

FOR MORE INFORMATION: <https://www.nasa.gov/content/nea-scout>

Deep Space Engine

OBJECTIVE: To qualify a thruster with mixed oxides of nitrogen (MON) containing 25% of nitric oxide and monomethylhydrazine (MMH) in the mixture for Lunar and Deep Space Lander Applications.

PROJECT DESCRIPTION

The Deep Space Engine (DSE) is an improved in-space chemical propulsion thruster. It offers multipurpose space mission utilization and economy-of-scale benefits because the engine is adaptable for spacecraft main propulsion, reaction control systems, and lander descent/ascent. Reducing propulsion system weight and volume increases available payload mass and/or acceleration capability, thereby expanding launch vehicle opportunities. Reduced propellant freezing point and thermal management power draw enables long-duration, ultra-cold deep space missions and reduces spacecraft heater power demand. Additionally, DSE retains fine grain impulse bit control for more precise control of lander descent/ascent trajectories. DSE offers enhanced affordability through improved designs, modern materials, and advanced manufacturing processes, which lower thruster unit cost for missions and reduce propulsion system costs. This technology is key to the enhanced affordability of science and exploration missions. The project goal is to qualify DSE thrusters (100 lbf and 5 lbf) to a technology readiness level 6 (TRL-6).



COURTESY OF FRONTIER AEROSPACE

FIGURE 1. Frontier Aerospace workhorse hardware in vacuum chamber.

The project aims to perform qualification tests that represent the mission duty cycles of both a potential future Technology Demonstration Mission (TDM) on the Astrobotic Peregrine Lunar Lander and the NASA Resource Prospector Lander. The primary challenge with mixed oxides of nitrogen (MON) containing 25% of nitric oxide (MON-25) is producing a high-performance thruster that does not exhibit combustion instabilities. (The 25 represents 25% of nitric oxide in the mixture).

Current state-of-the-art in-space thrusters use MON-1 or MON-3. Adding more nitric oxide to the mixture reduces the propellant freezing point but, consequently, raises the vapor pressure. The increased vapor pressure of MON-25 reduces the combustion stability margin of a MON-1 or MON-3 thruster. However, it has been demonstrated that stable operation is achievable with MON-25.

Led out of NASA's Marshall Space Flight Center, DSE will begin with a development effort called

workhorse testing. The workhorse testing will provide data that will be used to finalize a design for the qualification thruster. DSE will then undergo Design Verification Testing (DVT), which will further progress the workhorse design toward a flight weight design. Finally, qualification testing will validate the DSE flight requirements and provide TRL-6 data.



FIGURE 2. Deep Space Engine CAD rendering.

ACCOMPLISHMENTS

The DSE project has already completed an initial workhorse risk-reduction-development hot-fire test of the conceptual thruster. The risk-reduction testing demonstrated the high-performance and stability characteristics that are expected for the final design. Qualification testing will verify design requirements and robustness and qualify the thrusters to a TRL-6 by the end of testing. The following objectives were completed during the risk-reduction testing phase completed in September 2017:

- Demonstrated stable combustion performance at 200 psia (1.38 Mpa) chamber pressure and mixture ratio of 1.6.
- Demonstrated stable combustion at -4°F and 100°F (-20°C and 38°C).
- Demonstrated injector performance above 95% c^* efficiency.

SUMMARY

Frontier Aerospace has demonstrated MON-25 expertise and conducted a very successful Risk Reduction testing effort that has exceeded all success criteria.

There is a clear path to qualification of a MON-25/MMH thruster through TRL-6.

The qualified DSE will be a low-cost, lightweight, high-performing, domestic option for both lunar and deep space missions.

PROJECT MANAGER AND/OR PRINCIPAL INVESTIGATOR:

Gregory Barnett

PARTNERSHIPS: Frontier Aerospace Inc. and Advanced Mobile Propulsion Testing (AMPT)

FUNDING ORGANIZATION: Game Changing Development

FOR MORE INFORMATION: <https://gameon.nasa.gov/projects/deep-space-engine-dse/>

Technology Development of the Mars Ascent Vehicle Hybrid Fuel Grain

OBJECTIVE: To develop a manufacturing and machining process for a monolithic paraffin fuel (SP7) grain for use on the Mars Ascent Vehicle (MAV) hybrid motor.

PROJECT DESCRIPTION

NASA is developing a paraffin-based hybrid fuel grain applicable to the Mars Ascent Vehicle (MAV) in support of the robotic Mars Sample Return (MSR) campaign. The objective of the hybrid system development is to provide a multiple-motor restart capability with lower thermal conditioning requirements and complexity over a two-stage solid-motor alternative. NASA Marshall Space Flight Center's (MSFC's) task is to develop a manufacturing process to deliver consistent grains scaled for the flight MAV. MSFC is delivering the grains to industry partners for hot-fire testing and performance characterization. If successful, the technology may enable a reduced gross lift-off mass (GLOM) of the MAV that meets the packaging and environmental constraints of the MSR lander system with a decreased power burden for thermal conditioning. Sufficient performance may enable the mission to leverage heritage descent system technology and enable a solar powered lander solution.

ACCOMPLISHMENTS

The manufacturing of larger hybrid rocket motors is more difficult because the paraffin fuel, designated SP7, contracts by as much as 15% by volume during cooldown from liquid to solid state. This shrinkage leads to cracking and unbonding during the grain cooldown. These defects were attributed to a rigid mandrel and the stresses generated during the cooldown process. Although a soft, compressible mandrel was successfully tested, additional machining was required to meet dimensional requirements. Therefore, the use of an inner mandrel was discontinued. All inner diameter measurements are achieved using post-cooldown machining techniques. Fuel grain wafers (fig. 1) with shorter length/diameter dimensions were successfully

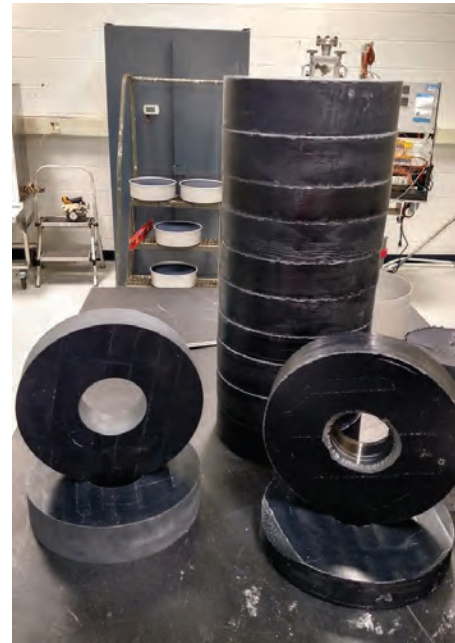

FIGURE 1. Fuel grain wafers.

produced using an ambient cooldown. A large number of these samples were manufactured, machined, and tested. However, some samples of the same dimensions cracked during ambient cooldown or during machining, indicating there is still residual stress in the fuel wafers this size.

In order to investigate the need for a slower cooldown rate, strategically placed thermocouples were introduced into a sample cooled in an ambient environment to monitor the intrinsic rate of cooling. The lagging thermocouple data was then used to develop an oven program that would mimic the slow cooldown rate. Fuel grain samples of various dimensions, including a full-scale monolithic (fig. 2), have been successfully produced using the slow, oven-controlled cooldown method. Slight changes to the process have resulted in cracked grains; therefore, future work includes understanding residual stresses caused by the oven-controlled cooldown process.

A subscale MSFC testbed, solid fuel torch, was used to investigate the differences in segmented and monolithic fuel grains. There is concern that the flow could be tripped at the segment interfaces due to small gaps or a difference in the regression rate of an adhesive

used to bond them. Inspection of the chamber pressure, grain weights, and uniformity, as well as the hardware, has indicated that there are differences caused by the grain interface configurations.

The oven-controlled slow-cooldown processing method developed by MSFC has yielded motor grains in both segmented and monolithic configurations. Hot-fire testing of this fuel with mixed oxides of nitrogen (nitrogen tetroxide and nitric acid) is ongoing at Space Propulsion Group (SPG) and Whittinghill Aerospace (figure 3), both based in California. The testing has resulted in several long-duration burns evaluating how to ignite and burn the wax-based fuel at full scale.



FIGURE 2. Monolithic paraffin fuel grain.

SUMMARY

This year, MSFC has established the capability to produce the wax-based fuel developed by the SPG of California. This fuel production has been demonstrated by manufacturing a monolithic grain. However, due to the large temperature swings on Mars, the flight grain may be multisegmented. The grains from this effort have been fired in all the full-scale testing.

PROJECT MANAGERS AND/OR PRINCIPAL INVESTIGATORS: John Dankanich, Jessica Chaffin, George Story
PARTNERSHIP: Jet Propulsion Laboratory
FUNDING ORGANIZATION: Science Mission Directorate
FOR MORE INFORMATION: <https://mars.nasa.gov/>



FIGURE 3. Motor firing at Whittinghill.

Fabrication and Characterization of a Grooved-Ring Fuel Element for a Nuclear Thermal Rocket

OBJECTIVE: To determine, through analysis and experiment, a process for fabricating carbide grooved-ring fuel elements for a nuclear thermal propulsion system.

PROJECT DESCRIPTION

This project sought to explore methods for fabricating carbide nuclear fuel elements in a grooved-ring geometry. Carbide fuels (e.g., zirconium carbide (ZrC), niobium carbide (NbC), vanadium carbide (VC), or uranium carbide (UC)) were studied due to the high melting point that can be achieved for the fuel element and the relatively low reactivity of carbides in a hydrogen environment. The grooved-ring geometry was targeted to increase heat transfer to the hydrogen propellant and increase the thrust-to-weight of the engine. Together these technologies have the potential to achieve higher specific impulse, resulting in greater propulsion system efficiency than other fuel forms. Such an improvement could enable more ambitious deep space exploration missions and reduce logistical costs.

Carbide fuels consist of a blend of refractory metal carbide compounds such as NbC, ZrC, VC, or UC. Carbide compounds are attractive for use as nuclear fuels due to their high melting points (up to nearly 4,000 K). In fact, ZrC and NbC have been used as coatings for graphite fuel forms in some of the Nuclear Engine for Rocket Vehicle Application (NERVA) engines. Carbide fuel elements could, in theory, operate at higher tem-

peratures than other fuel forms which would provide more energy for thrust conversion. Also, partial dissociation of hydrogen would decrease the average molecular weight of the propellant. Both contribute toward a higher specific impulse. Additionally, carbide compounds are less reactive in a hydrogen environment than other fuel forms.

Grooved-ring fuel elements are built from grooved washer-shaped disks. Once stacked, propellant flows from outside the cylinder through grooves to the central passage before exiting the fuel element. This creates much larger surface area in the element to improve heat transfer over cylindrical passages in hexagonal elements. As a result, a larger thrust-to-weight engine could be built.

These technologies would improve the performance of current nuclear thermal engine concepts. To develop this fuel element, a fabrication process must be developed to produce the carbide material with the desired properties—such as material distribution and density and methods for creating the geometry—must be identified. Experiments, supported by neutronics and fluid/thermal analysis, were carried out. Tricarbide samples of NbC, ZrC, and VC were produced with sifting, milling, and spark plasma sintering processes. Samples were then analyzed through an electron scanning microscope, x-ray diffraction, and other techniques to characterize the carbide material produced. Additionally, reactivity with a hot hydrogen environment was assessed up to 2,750 K using the compact fuel element environmental test (CFEET) system. Results of experiments and analysis have been documented and are driving the design of experiments to further develop the fabrication process.

This project builds off of historical nuclear thermal propulsion experience and complements ongoing research into other fuel forms underway at NASA and industry partners.

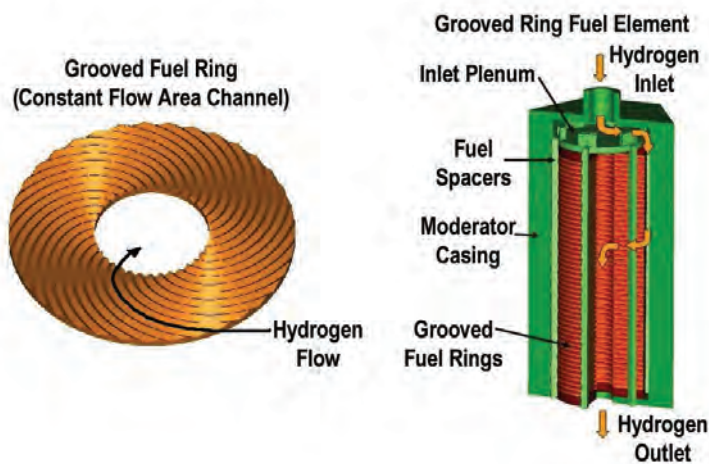

FIGURE 1. Diagram of a grooved-ring fuel element.

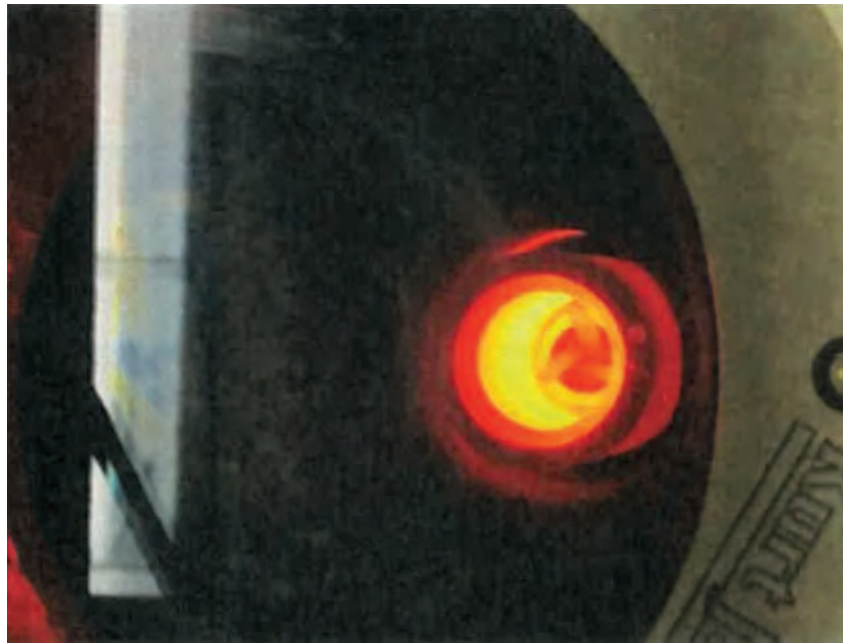

FIGURE 2. Carbide units in CFEET being heated to $\approx 2,200$ K in a hydrogen environment.

The exploration of multiple fuel forms offers opportunity to benefit from shared data. The ongoing effort to develop fuel elements for nuclear thermal propulsion can then evaluate and select the optimal fuel form/geometry. The next step in this research is to experiment with heat treatments to reach a solid solution and improve material distribution while minimizing oxidation.

ACCOMPLISHMENTS

In FY2017, the team ran materials experiments in which tricarbide units were created and characterized with several analytical tools. Analysis and models drove material experiments which showed that spark plasma sintering would produce high-density samples from carbide powder. High density and reasonable distribution of material could be achieved.

Tricarbide units sintered from unmilled powder were shown to hold up well in a hot hydrogen environment (tested in CFEET) and showed indications of developing into a solid solution, a very promising result for fuel element fabrication.

While milling powders to a smaller size is expected to further improve material distribution, the current process results in oxidation. The oxidation led to severe cracking and blister formation in the samples after exposure to hot ($>2,500$ K) hydrogen in CFEET.

This was a result of the specific milling process. Improved material distribution without oxidation is expected to be achieved through modification of the milling process.

SUMMARY

This work showed success in fabricating tricarbide units of NbC, ZrC, and VC that reached desired densities and reasonable material distribution. Units showed low material loss and reactivity when heated to $>2,000$ K in a hydrogen environment. Analysis of units tested to high temperatures even shown signs of moving toward a solid solution.

The path forward will be to resolve the problem with the milling process, improving material distribution. Tricarbide units will be processed in a graphite furnace to attempt to create a solid solution and then tested to higher temperatures in a hydrogen environment to further characterize their performance in reactor conditions. The tricarbide units will also be cut using a water jet to produce the grooved-ring geometry. Tricarbide grooved-ring elements show promise as a fuel form for improved nuclear thermal engines.

PRINCIPAL INVESTIGATORS: PI: Brian Taylor, Co-PI's: Bill Emrich and Marvin Barnes

FUNDING ORGANIZATION: Center Innovation Fund

Pulsed Fission-Fusion (PuFF) Target Design and Containment System

OBJECTIVE: To develop targets for the pulsed fission-fusion (PuFF) propulsion system and a system to contain the implosions during testing.

PROJECT DESCRIPTION

The pulsed fission-fusion (PuFF) propulsion system implodes very small pellets containing the fission-fusion fuel, hereafter called targets, which convert into plasma and expand against a magnetic nozzle for thrust. The PuFF system has shown considerable promise as an in-space propulsion system that can open up the solar system and beyond for exploration. A concept vehicle using the PuFF process is shown in figure 1. Design of the targets was the first goal of this year's effort. The second goal was to design a containment system that would allow viewing of the implosion process during testing but also be able to contain the resulting energy release.

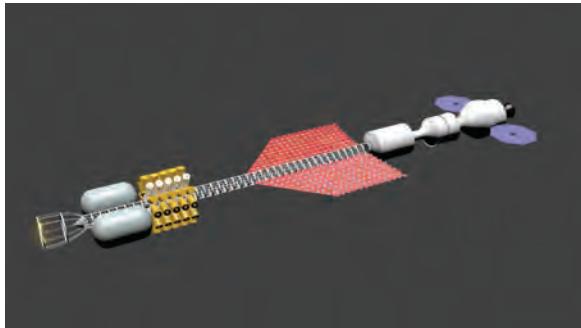

FIGURE 1. Layout of the PuFF concept vehicle.

ACCOMPLISHMENTS

There are many constraints to the target's design. We wish as small an energy release as possible, as multiple small explosions are easier for the magnetic nozzle to contain than fewer larger explosions; however, detonations are easier to initialize when the fuel is larger. To counter that, smaller targets must be compressed to a much higher density.

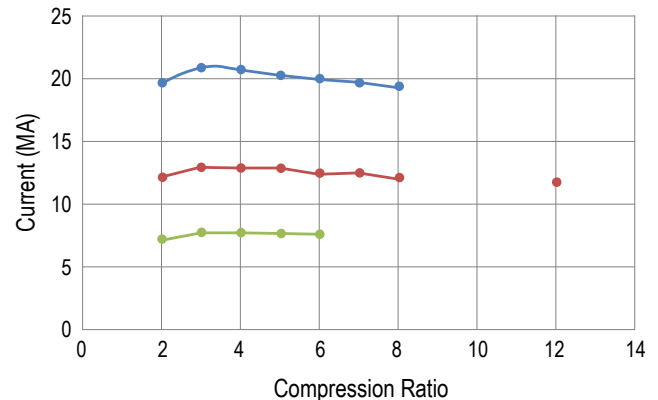

FIGURE 2. Required current/compression ratio for various criticality factors. The figure also shows that a smaller target with a larger compression ratio requires approximately the same current as a larger target with a lower compression ratio.

The PuFF system uses a z-pinch to compress the targets. Based on limits given by the Nuclear Regulatory Commission (NRC), we decided to go forward with a target that will experience at $\times 5$ compression. Based on that energy release, we started design of the containment system. Our concept uses two solid hemispherical pieces on the end caps with successive cylinders of polycarbonate in the cylindrical shell. This arrangement can be seen in the figure below. In the figure, the target can just be seen inside a cylinder of lithium in the center of the containment vessel. The current causing the z-pinch flows through the copper inserts travelling through the hemispheres to the lithium liner.

We have baselined a containment system that would use 60 cylinders of polycarbonate, concentric to the target, each 1/8 in thick with 1/8 in spacing between the cylinders. The spacing allows fragments to break up

and vaporize, thus spreading the explosive load across the entire surface of the cylinders. The entire system will weigh about 150 kg and be able to contain the explosive force previously mentioned.

Our team has completed extensive calculations in the fields of neutronics, plasma physics, and thermodynamics/heat transfer to complete this preliminary design of the PuFF target and containment system. We have also had several conversations with DOE and the NRC to develop our eventual testing plan regarding PuFF. We have gained the surprising insight that the z-pinch current is largely independent of target size or compression to reach a certain criticality.

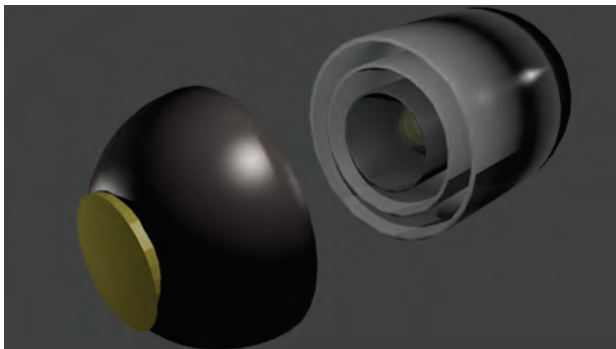

FIGURE 3. A concept drawing of the containment system to test nuclear targets.

SUMMARY

The PuFF system continues to meet expectations through development and has yet to raise a concern about performance or viability. In fact, the biggest challenge to date is to keep the energy release low enough to not make the structural loads on the vehicle too severe. Future work will focus on more detailed iterations of the energy release process and to start testing to determine experimentally the best target size and geometry for optimal performance.

PROJECT MANAGER AND/OR PRINCIPAL INVESTIGATOR: Rob Adams

PARTNERSHIP: University of Alabama in Huntsville

FUNDING ORGANIZATION: Center Innovation Fund



Multiscale Nuclear Thermal Propulsion (NTP) Nuclear Fuel Material Simulation

OBJECTIVE: To begin developing an innovative, multiscale, fuel element materials modeling capability to simulate ceramic metal (CERMET) fuel performance and reduce testing needs

PROJECT DESCRIPTION

NASA's Nuclear Thermal Propulsion (NTP) project is focused on determining the feasibility and affordability of an NTP engine for space exploration. Although the technology was demonstrated in the 1960s, many questions concerning development and affordability still remain. A key technology challenge for an NTP system is the fabrication of a stable high temperature fuel material. Current work is focused on optimizing ceramic metal (CERMET) fuels using low-enriched uranium. Verification of the fuel materials will require subjecting prototypical samples to the combined effects of radiation and high-pressure hydrogen at temperatures near 3,000 K. There are currently no facilities in the US that are capable of producing the required environment. Modifications to existing test reactor facilities to simulate a relevant environment could take years and be cost prohibitive. The goal of this Center Innovation Fund project was to start the development of an innovative multiscale fuel element materials modeling capability to predict the CERMET fuel performance. The modeling tool could potentially reduce the amount of required testing and reduce development costs.

ACCOMPLISHMENTS

The Center Innovation Fund project leveraged a multiscale modeling approach pioneered for light water reactor (LWR) fuels to simulate performance in a prototypical NTP environment. The objective was to conduct a proof-of-concept simulation and illustrate the applicability of existing MARMOT (mesoscale) and BISON (macroscale) codes to CERMET fuels in NTP conditions. Simulating the degradation of properties in CERMET fuels under the harsh conditions will require innovative computational analysis not currently available. The Center Innovation Fund effort required the unique processing, microstructure, and performance relationships of proven codes to be adapted. This will

be challenging due to the complex microstructure evolution and thermodynamic materials degradation at operating conditions and its impact on the fuel properties. However, development can be reduced by coupling existing knowledge of uranium dioxide (UO_2) behavior in LWRs, expertise in SOA multiscale mod-

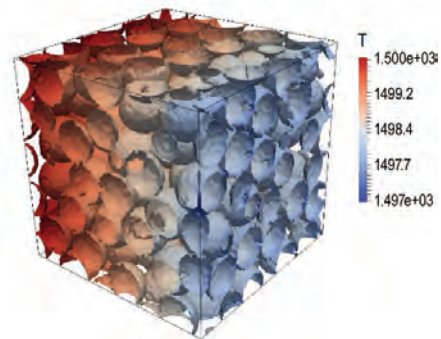

FIGURE 1. 3D reconstruction of fuel microstructure.

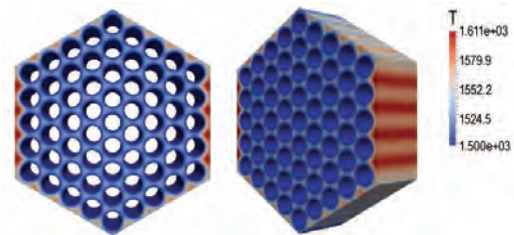

FIGURE 2. Thermal profile for 61 channel fuel element.

eling for nuclear reactor fuels at Penn State University, and expertise in NTP CERMET fuels fabrication and testing at Marshall Space Flight Center. The result will be a demonstration of a unique capability to affordably simulate NTP fuels and reduce cost, schedule, and risk. Given the time required to develop and demonstrate new aerospace materials, especially with the added complexity of handling uranium, the proposed simulation approach may be the best opportunity to provide a technical basis for affordable NTP fuels cost and schedule estimates in the 2020 timeframe.

The modeling tool, MOOSE, was used to predict effective thermal conductivity at different temperatures and volume fractions of uranium dioxide. The effective thermal conductivity-versus-temperature data can be seen in figure 3. As expected, the effective thermal conductivity decreased as temperature increased. Varying the volume fraction of uranium dioxide did not affect thermal conductivity; however, when the volume fraction of uranium dioxide was decreased to zero, a 4.7% discrepancy was discovered within the prediction. The effective thermal conductivity prediction was compared to the Bruggeman analytical model.¹ The predicted thermal conductivity values followed the trend defined by the Bruggeman model; however,

SUMMARY

This Center Innovation Fund effort was highly successful at achieving all of its stated near-term objectives—namely, to initiate the development of a multiscale modeling simulation tool with applicability to NTP fuels. MOOSE was successfully used to predict the thermal properties of a CERMET fuel material within a reasonable error band. The thermal conductivity correlated well with other analytical models. More importantly, this work proves that, within the framework of MOOSE, microscale material data can be used to predict mesoscale properties which can in turn be used to simulate macroscale fuel behavior.

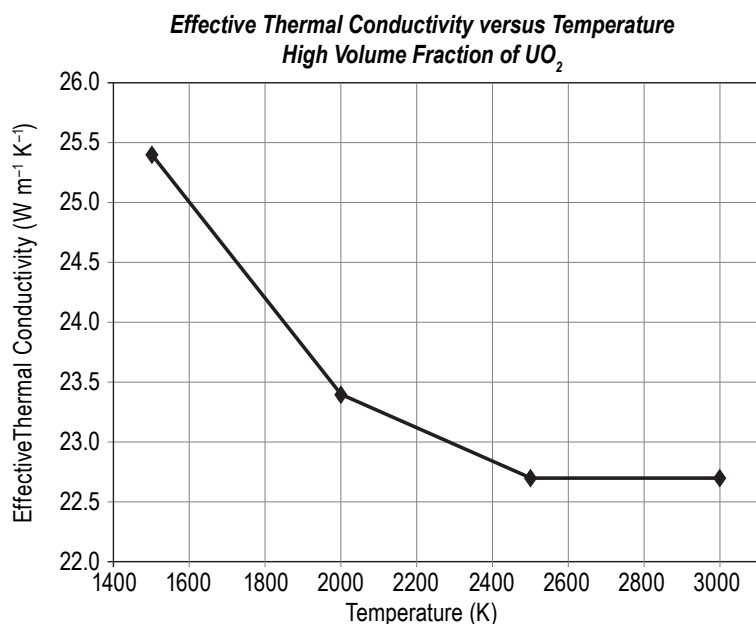

FIGURE 3. Effective thermal conductivity versus temperature high volume fraction of uranium dioxide.

the values of effective thermal conductivity calculated using MOOSE were approximately 20% lower than the analytical model. The thermal conductivity values at the mesoscale were used in an engineering scale simulation. The temperature profile throughout the hexagonal fuel elements were evaluated. The temperatures are higher on the outer parts of the fuel element and lower closer to the channels, where the fuel is being cooled by the hydrogen. Fuel concepts with more channels perform better due to their larger cooling surface area. Therefore, the 61-channel concept exhibited best performance.

Future work is required to refine the modeling tool to include mechanical properties data and other CERMET fuel design concepts. Future funding has been requested from the NTP project, and efforts are being made to disseminate the results of the project to the broader community.

REFERENCE

1. Miller, J.V. "Estimating thermal conductivity of CERMET fuel materials for nuclear reactor application," NA-SA-TN-D-3898, NASA Lewis Research Center (now Glenn Research Center), Cleveland, Ohio, 31 pp., April 1967.

PROJECT MANAGERS AND/OR PRINCIPAL INVESTIGATORS: Robert Hickman and Marvin Barnes
PARTNERSHIP: Penn State University
FUNDING ORGANIZATION: Center Innovation Fund

Electric Sail Tether Deployment System

OBJECTIVE: To address a major technical challenge of the electric sail (E-sail) propulsion concept through development and testing of a tether deployment system.

PROJECT DESCRIPTION

The electric sail (E-sail) propulsion system concept consists of positively charged, long, thin wires extending radially outward from a central spacecraft. The wires or tethers must be biased using a high-voltage power supply, such that thrust is produced due to the solar wind. The E-sail concept shows great promise for achieving missions to the heliopause with higher performance (characteristic acceleration) than solar sail concepts. However, the E-sail concept has significant technical challenges related to the deployment and control of numerous long thin wires or tethers. The difficulty of deploying multiple tethers such that they do not tangle or touch each other is obvious, considering that a typical full-scale E-sail design involves the use of 10s to 100 20-km-long tethers in a hub-and-spoke architecture. Additionally, there have been multiple mission failures involving tether deployment and control over the past 20 years. This project addresses the challenge of E-sail tether deployment through development and testing of a robust and simple tether deployment system.

ACCOMPLISHMENTS

The approach followed in this project to develop a robust tether deployment system was to start with a single-tether, two-6U CubeSat configuration developed by the Advanced Concepts Office for a potential Technology Demonstration Mission project. The project included the following four areas of work: (1) Tether dynamic modeling/simulation by project partner Tennessee Tech University, (2) E-sail single-tether prototype development and testing in the Marshall Space Flight Center (MSFC) Flight Robotics Lab, (3) space environmental effects testing of tether materials to help identify best materials for a demonstration mission, and (4) axial dynamic testing of tether materials to support modeling efforts. These work areas were needed to address technical challenges and work toward a flight demonstration mission for E-sail.

Further, an innovative agile engineering approach was utilized by the project team, where E-sail sin-

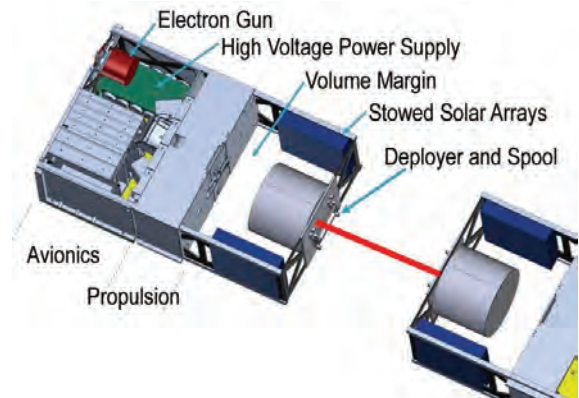

FIGURE 1. Single-tether, two-6U CubeSat E-sail configuration.

gle-tether prototype designs were iteratively developed through testing to solve problems and identify design improvements. The agile approach was ideal for this low Technology Readiness Level (TRL) project, since there were many unknowns in prototype tether deployer development that could only be discovered through iterative cycles of construction and testing. This approach has been successfully used in software development and low-TRL hardware development programs in government and industry. The next step after this year's work is to continue E-sail prototype development and maturation through a follow-on Technology Investment Program/Engineering Technical Excellence project. This follow-on project has already been awarded by the Center.

Extensive tether deployment modeling and simulation were accomplished by project partner Tennessee Tech University, for the following three cases for the single-tether, two-6U CubeSat E-sail configuration: (1) Rotational tether deployment, with primary 6U CubeSat free to rotate in plane of the MSFC Flight Robotics Lab floor and the secondary 6U free; (2) linear tether deployment, with primary 6U fixed and propulsive force applied to free secondary 6U; and (3) linear tether deployment with both 6Us free and propulsive forces applied to both (more representative of a future flight experiment). Some of the simulation cases included frictional restraint applied to the tether during

deployment by a brake device provided by project partner Tethers Unlimited, Inc. Simulation results were valuable for understanding the propulsive and braking forces needed for controlled tether deployment.

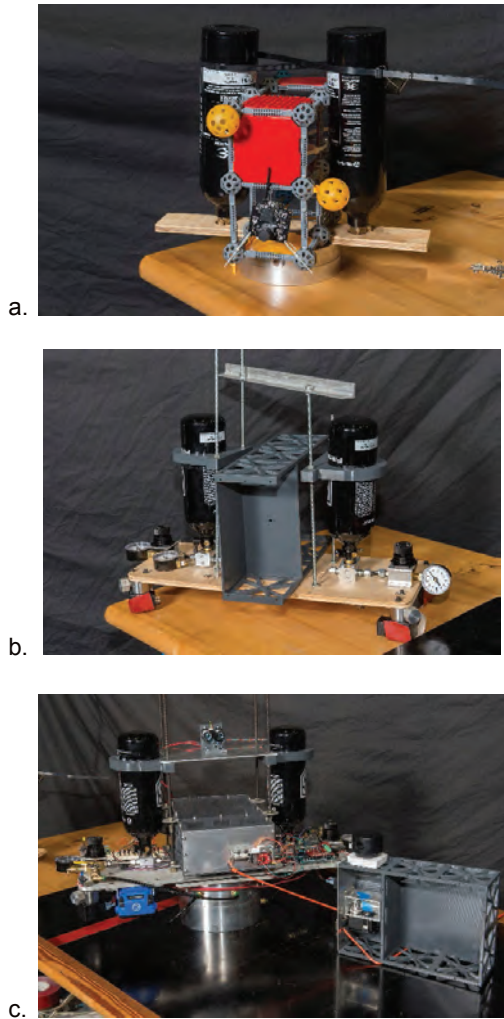

FIGURE 2. Design iterations of single-tether E-sail prototype test article: (a) Initial mockup, (b) intermediate article, and (c) current article.

Single-tether E-sail prototype designs for testing in the Flight Robotics Lab were developed in an agile engineering team-based approach, starting with a simple mockup and progressing iteratively to advanced prototypes with tether deployer and brake, propulsion system, electrical components, and navigation com-

ponents. Accomplishments included 3D printing of the prototype 6U frames, propulsion system (cold gas thruster) design using CFD and CAD tools, electrical design, software development, overall system integration, and demonstration testing in the MSFC Flight Robotics Lab.

SUMMARY

This project resulted in successful development of a single-tether two-6U prototype E-sail test article, which has been demonstrated in the MSFC Flight Robotics Lab. The final E-sail prototype will include autonomous propulsive tether deployment, while monitoring tether tension, location on the floor, distance between tether ends, acceleration, velocity, and propellant used. Refinements in a follow-on project will allow fully autonomous operation.

PROJECT MANAGER AND CO-INVESTIGATORS: Mike Tinker, Tom Bryan, Jason Vaughn, Bruce Wiegmann

PARTNERSHIPS: Tennessee Tech University; Tethers Unlimited, Inc.

FUNDING ORGANIZATION: Technology Investment Program

Liquid Oxygen (LOX) Expansion Cycle: A Dual Cooled-Expander Cycle Engine Using Hydrogen and Oxygen

OBJECTIVE: To develop a liquid oxygen (LOX) expansion cycle rocket engine concept.

PROJECT DESCRIPTION

The liquid oxygen (LOX) expansion cycle (LEC) rocket engine concept employs two expander cycles, one to pump the fuel and one and oxidizer. The LEC will serve as an orbit-transfer engine to propel a payload from low earth orbit (LEO) to geosynchronous orbit (GEO) and to achieve escape velocity for interplanetary missions. This research will employ industry standard design tools to create a model of an upper stage engine and then operate that engine in a simulation to optimize performance.

The primary goal is to develop a power balance model of a high-performance dual cooled-expander engine (DECE) using LOX to cool the nozzle and liquid hydrogen (LH_2) to cool the chamber to validate the performance benefits and feasibility of this concept.

Determining the feasibility of this enabling technology will allow the removal of the number one catastrophic failure mode in current liquid rocket engines—the interpropellant seal package (IPS)—and provide a higher-performing cycle for use in upper stage applications. Deliverables will be a validated power balance model utilizing the DECE.

NASA’s Marshall Space Flight Center (MSFC) has provided LOX cooling data obtained from early NASA Glenn Research Center (GRC) testing reports to validate The University of Alabama power balance model. Optimization of the model is in work using existing RL10 models and the Exquadrum test data when it becomes available.

ACCOMPLISHMENTS

This research effort has benefited from previous efforts modeling a dual expander aerospike engine (fig. 2). Notably, the power balance model (NASA’s Numerical Propulsion System Simulation) was incorporated into an optimization code (ModelCenter). The power balance model was simplified for robust operation but successfully captured the physics of the engine cycle.

The model has been adapted to the DECE and is currently being validated. Efforts to verify the modeling approach are underway. The RL-10a-3-3a is being modeled and will be compared with experimental results.

Additionally, the DECE engine cycle preliminary results are promising but need to be better grounded in the physical constraints. Design parameters have been chosen for minimum pressure loss and maximum performance (chamber pressure). The results from the RL-10 modeling effort will provide the needed grounding for this model.

Several key features of the ModelCenter optimization scheme have been incorporated into the DECE engine model. (Note: The DECE and LEC notations can be used interchangeably.)

Currently, having to use a 0.456 correction factor to the Bartz heat transfer relationship has to be used to match the existing RL10 data. The Bartz correlation has been the standard for many years and this analysis may have uncovered an area where Bartz cannot be used.

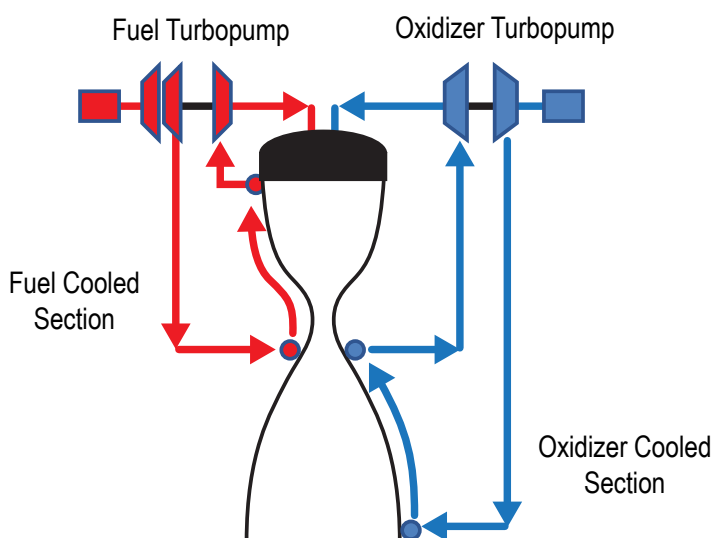

FIGURE 1. Dual cooled-expander concept.

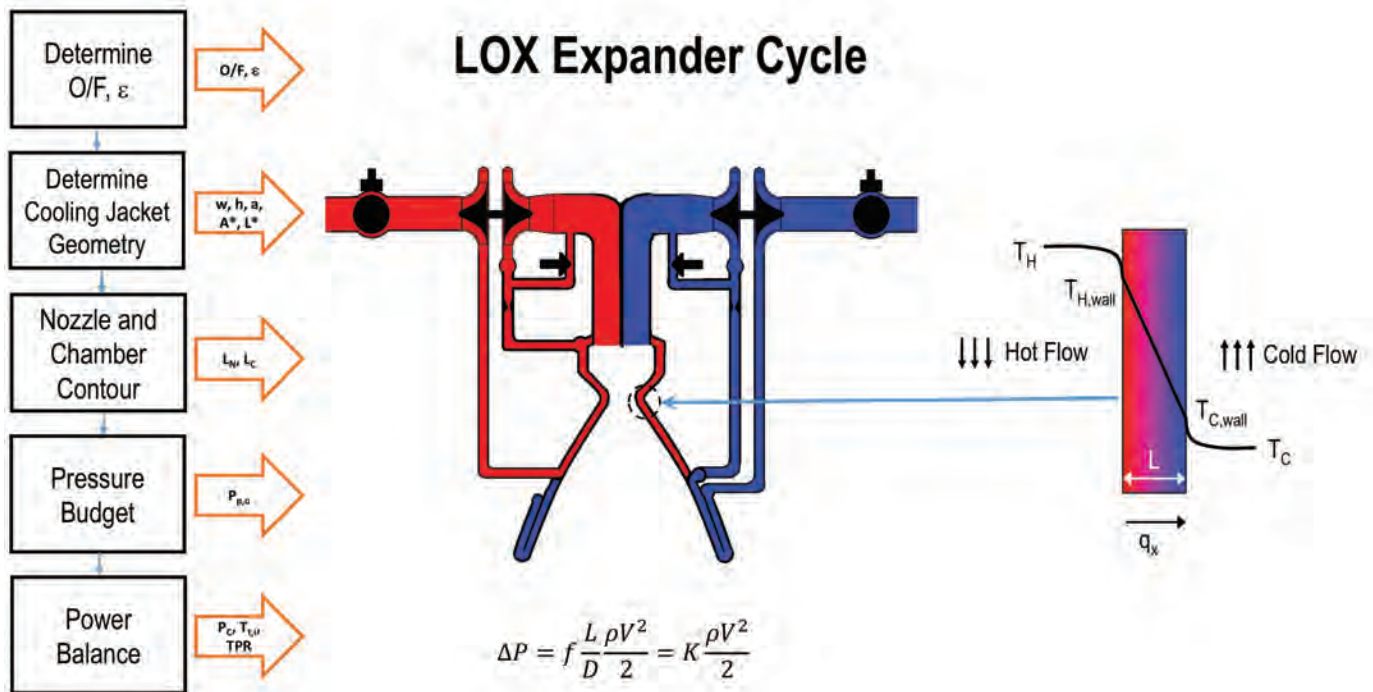

FIGURE 2. Example of a dual expander aerospike engine model.

SUMMARY

The major challenge of this concept is to get enough heat (energy) to drive the turbopumps (turbines specifically) without melting the chamber or nozzle. Figure 3 shows the effect of cooling the chamber and nozzle using both LH₂ and LOX. With these conditions, the LEC will close, but the uncertainty is high at this time.

Future tasks include developing a more accurate method than the Bartz Correlation to better model the physics of the heat transfer. This includes establishing

better analytical/empirical relationships between the propellants and the convective heat transfer coefficients. This is necessary prior to determining if LOX cooling is feasible for driving the LOX turbopump to actually close this expander cycle.

PROJECT MANAGER(S) AND/OR PRINCIPAL INVESTIGATOR: Joe Leahy

PARTNERSHIPS: NASA MSFC, NASA GRC, and The University of Alabama

FUNDING ORGANIZATION: Cooperative Agreement Notice

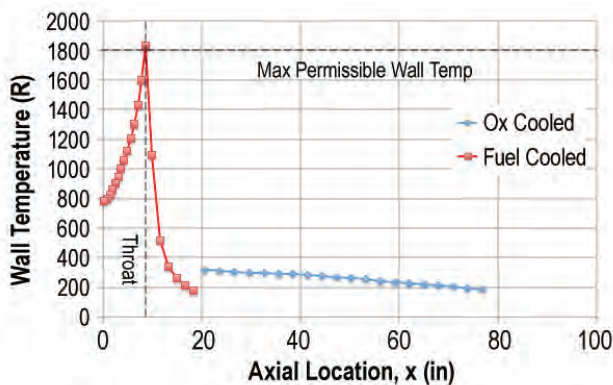

FIGURE 3. Wall temperature using oxygen as coolant section.

Low-Cost Plasma Micropropulsion Using 3D Printing and Off-the-Shelf Components

OBJECTIVE: To develop a novel low-power, low-cost, and launch compliant micropropulsion thruster for small satellite applications.

PROJECT DESCRIPTION

This project sought to develop and study a new low-cost micropropulsion concept for satellite propulsion called the microwave microplasma microthruster (3MT). The thruster utilizes microwave resonators to generate a microplasma. The project takes advantage of additive manufacturing and circuit fabrication techniques to build the major components. The thruster is designed to operate with microwave power at standard communications frequencies (e.g., 2.45 GHz) and at low power (<10 W) to directly tap into the existing communications equipment on satellites. This eliminates the need for a dedicated power processing unit. The thruster can operate on a range of gaseous and condensable solid propellants such as iodine.

The specific microplasma device developed here is called the split-ring resonator (SRR), which is shown in figure 1. The ring circumference is sized to be half the wavelength of the driving signal. A 2.45-GHz device would have a mean diameter of ≈ 1.22 cm. A small gap (≈ 500 μm) in the ring creates large amplitude electric fields between the two ends of the gap to ionize the surrounding gas to create a microplasma.

The thruster body is built with additive manufacturing, either from acrylonitrile butadiene styrene (ABS) plastic using fused deposition modeling, or Inconel using electron beam sintering, as shown in figure 2.

ACCOMPLISHMENTS

The innovation of this project is the use of a low-power microplasma generator based on the common microwave strip resonators. While these devices are commonly seen in electronics, their ability to produce high-density and high-energy plasmas at small scales is new. We have developed the capability to design, fabricate, and operate these SRRs and have studied their performance and properties. The major key milestone



FIGURE 1. An SRR fabricated with photolithography. The SMA connector supplies the driving microwave power. The unseen backside of the white substrate is fully clad in copper and acts as the ground plane.

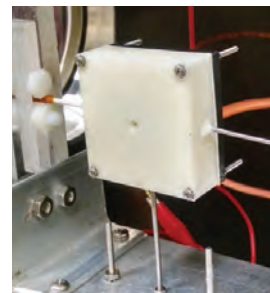

FIGURE 2. The ABS prototype made with fused deposition modeling.

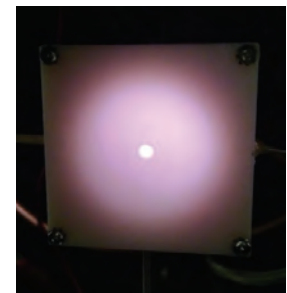

FIGURE 3. The thruster operating on argon in the vacuum chamber.

was testing an electrothermal microthruster based on the SRR at Marshall Space Flight Center (MSFC) done in Fall 2016. This project provides a new-yet-unexplored method to generate a plasma for in-space plasma propulsion. The SRRs are especially suited for small-scale devices, thus micropropulsion for small satellites. The project also complements other efforts to develop small satellites, especially power requirements. Due to the microwave frequency operation of the SRRs, a thruster using this technology could utilize the same power source build for the communications system, thereby removing the need for a power processing unit just for the thruster. The next steps for this technology

and research is to conduct study of nested-ring resonators, which we are calling concentric split-ring resonators (CSRR), and integrate the SRR into a miniature ion engine design. The CSRR has two or more nested rings to produce multiple discharges from one power input, thus increasing the overall plasma volume with minimal power increase.

The 3MT has been tested with both argon and air as a propellant at 10–100 Torr and has little difficulty sustaining the plasma with as little as 1 W of microwave power as seen in figure 3. The thruster body has been fabricated from ABS plastic and Inconel with additive manufacturing methods. An alternative SRR fabrication method was successfully tested using iron-on masks that greatly reduced the time from 4 hr in a clean room for photolithograph to just 30 min in a simple fume hood. The total cost per ABS unit is <\$200, the majority of which is the cost of the substrate. From design to assembly, the ABS unit takes less than 2 days to produce, largely depending on the speed of the 3D printer. Thrust measurements of the device show 1–5 mN of thrust at nominal operating conditions. Three conference papers on the project have been presented at the 2015 AIAA Propulsion and Energy and 2016 AIAA SciTech Forums, and a journal paper has been published in *IEEE Transactions on Plasma Science*.

SUMMARY

The 3MT and SRR technologies have demonstrated low-cost and low-power generation of a plasma for small scale space propulsion. The collaboration between MSFC and the University of Alabama in Huntsville (UAH) brought together the technical expertise, facilities, and equipment to be successful in this project. The final result is a better understanding of the design, operation, and physics of the SRR and micro-plasma which will be used to further develop other micro propulsion technologies and other terrestrial plasma applications.

PROJECT MANAGER AND/OR PRINCIPAL

INVESTIGATOR: Kunning G. Xu, UAH

PARTNERSHIP: Kurt A. Polzin

FUNDING ORGANIZATION: Cooperative Agreement Notice

Multimode Micropropulsion for Small Spacecraft

OBJECTIVE: To design a single propulsion system (one propellant tank, one set of feed lines/valves, one thruster) that can be operated in either high-thrust, low-specific impulse chemical mode or low-thrust, high-specific impulse electric mode.

PROJECT DESCRIPTION

Small, micro, and CubeSat (<100 kg) spacecraft are being considered for increasingly ambitious and complex science, exploration, and technology demonstration missions. Many of these future missions will require a flexible thrust history composed of high-thrust impulsive maneuvers and low-thrust precision attitude control and station-keeping. Maximum mission flexibility and enhanced smallsat capability can be obtained with a propulsion system that can execute both high- and low-thrust maneuvers—a multimode micropropulsion system.

The project goal is to demonstrate each mode of operation. The objectives are to (1) synthesize the novel green binary mixture monopropellant (achieved in this project), (2) demonstrate electrospray of the propellant (achieved in this project), (3) demonstrate exothermic decomposition on a heated catalyst (achieved in this project), and (4) demonstrate microtube operation of the propellant (not achieved in this project but recently demonstrated by commercial partner Froberg Aerospace, LLC, as part of their Small Business Innovation Research project).

The innovation is a multimode micropropulsion system that consists of an integrated chemical microtube thruster and electric electrospray thruster. The system is a single-propulsion system (one propellant tank, one set of feed lines/valves, one thruster) that can be operated in either high-thrust, low-specific impulse chemical mode or low-thrust, high-specific impulse electric mode. A microtube/emitter (≈ 0.1 -mm diameter) is fed with our novel ionic liquid (IL) propellant blend. If the tube is heated (110°C), the propellant catalytically and exothermically decomposes to produce high-temperature gaseous exhaust species with a specific impulse of 180 s. If instead a potential difference ($\approx 1,800$ V) is applied between the tube and an extraction electrode, ions and charged droplets are extracted from the IL propellant with a specific impulse of >780 s. A collection or array of microtube/emitters is a thruster. The propulsion system consists of a propellant tank, pressurant tank, thruster, feed lines, valves, power processing unit, and batteries.

Both the chemical and electric modes of operation use the same propellant. The propellant is a novel green/nontoxic binary mixture of ionic liquids developed in-house. It is a binary mixture of hydroxylammonium nitrate (HAN) with an IL fuel (1-Ethyl-3-methylimidazolium ethyl sulfate [Emim][EtSO₄]). Our previous work has synthesized this propellant and shown it to be electrosprayable for electric mode and continuously combusted for chemical mode operation. This IL propellant and its constituents are compatible with com-

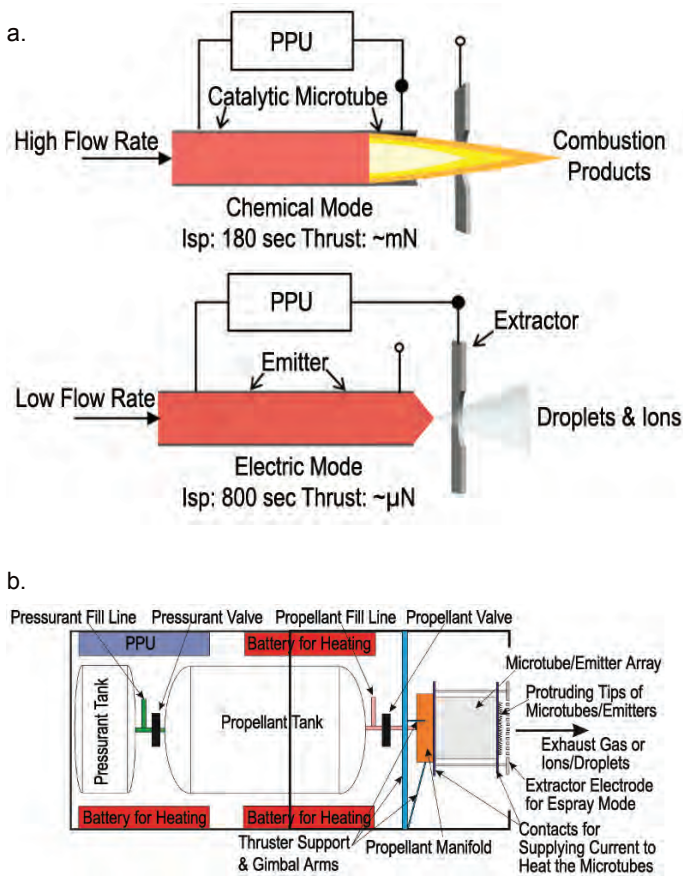

FIGURE 1. Schematics of: (a) Combination of a chemical microtube thruster with an electric electrospray thruster and (b) propulsion system in 2U CubeSat form factor.

mon spacecraft materials, environmentally friendly, have low volatility, and do not require special personal protective equipment to work with other than gloves and eye protection.

ACCOMPLISHMENTS

In this project, we showed, for the first time, a propellant that can be both electrospayed and exothermically decomposed on a heated catalyst. (More recent results by SBIR awardee Froberg Aerospace, LLC, have shown stable long-duration microtube combustion.) We have safely and repeatedly synthesized numerous batches

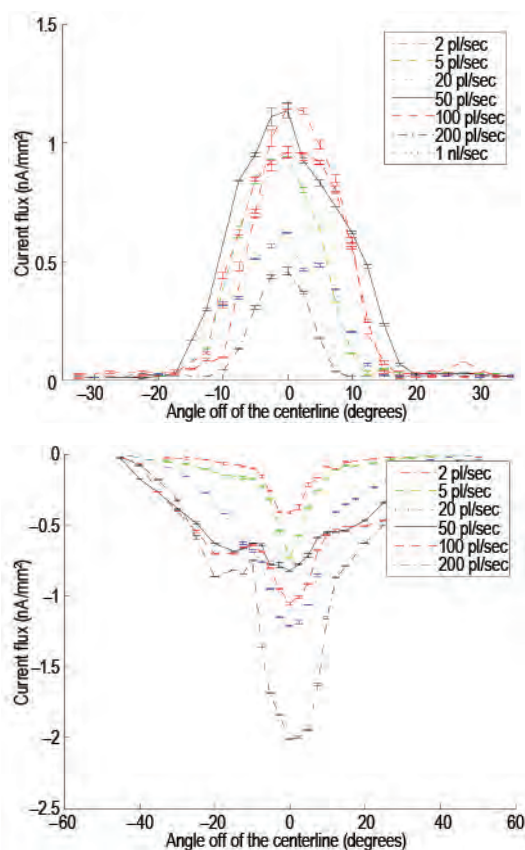

FIGURE 2. Current density profiles from electrospay demonstration at low (high-performance) flow rates.

of our binary mixture propellant hydroxylammonium nitrate (HAN) with IL fuel [Emim][EtSO₄], resulting in >200 mL of total propellant synthesized to date. The synthesis process is relatively easy and repeatable and could be easily scaled to produce larger batches.

We have demonstrated electric electrospay mode of the multimode micropropulsion concept in a single emitter

configuration. Using a syringe pump feed system for flow rates ranging from 2 to 1,000 pL/s, results of total emitter current and extraction voltage were used to predict electrospay performance. Thrust and specific impulse for the anion and cation modes are 31 nN and 1,100 s, and 50 nN and 1,800 s, respectively, at a flow rate of 2 pL/s.

We have demonstrated rapid exothermic decomposition and measured the chemical reaction rate relevant to chemical microtube mode. We tested the propellant for catalytic decomposition in a microreactor setup, along with AF-M315E. The [Emim][EtSO₄]-HAN mixture was significantly more reactive than the AF-M315E (pressure rise rates of ≈ 25 mbar/s versus ≈ 5.5 mbar/s). Platinum catalyst was found to be most effective with a decomposition temperature of 85 °C. From the data, we determine the activation energy and frequency factor for use in the one-step Arrhenius rate equation and use these results in a plug-flow reactor model to predict the regime of stable decomposition and combustion. Finally, our linear burn rate study indicates that the propellant has a burn rate of 22.8 mm/s, similar to other HAN-based propellants.

SUMMARY

Small spacecraft can benefit by having a propulsion system operating with a common propellant that can complete both high thrust/low specific impulse and low thrust/high specific impulse maneuvers. This project demonstrated the synthesis of a propellant that can be used in a decomposition monopropellant thruster providing high thrust and accelerated electrically to high specific impulse through an electrospay thruster. The HAN-based propellant is a relatively benign ‘green’ propellant that is environmentally friendly, has low volatility, and does not require special personal protective equipment, making it easy to conduct development testing in the lab and flight fueling of a spacecraft prior to launch.

PROJECT MANAGERS AND/OR PRINCIPAL

INVESTIGATORS: Joshua L. Rovey & Kurt Polzin

PARTNERSHIPS: Missouri University of Science and Technology, PI is now at University of Illinois at Urbana–Champaign

FUNDING ORGANIZATION: Cooperative Agreement Notice

Dual-Mode Green Propulsion Proof of Concept: Providing Both Innovative Green Propulsion and Micropropulsion for Small Spacecraft

OBJECTIVE: To mature bimodal chemical-electric propulsion systems with electro spray microfluidic electro spray propulsion (MEP) thrusters featuring high performance and efficient packaging.

PROJECT DESCRIPTION

Electric propulsion offers unparalleled savings in propellant use for a given impulse compared to chemical thrusters. However, because of power limitations, electric thrusters produce significantly smaller forces, resulting in slower maneuvering. Ideally, both chemical and electric thrusters could be used to optimize propellant use and firing times. The goal of this work is to investigate a propulsion system capable of distributing a single propellant (AF-M315E) to a chemical thruster and an electric propulsion microthruster. Such arrangement would minimize complexity and optimizes overall system packaging. This is particularly relevant for volume and mass-constrained small satellites that could require both high specific impulse (at low thrust) for long-term efficient firings and high thrust (at low specific impulse) for rapid maneuvering. To achieve this goal, we design, build, and test a proof-of-concept dual system that delivers propellant to both a chemical monopropellant thruster and an electro spray microelectric propulsion (MEP) thruster.

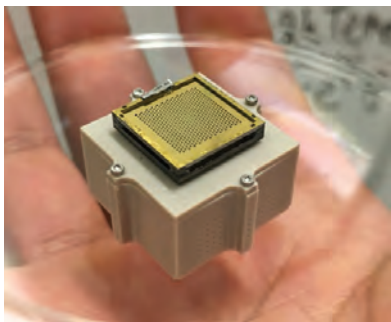

FIGURE 1. MEP thruster and reservoir.

ACCOMPLISHMENTS

Our team investigates the use of electro spray thrusters as the electric propulsion device for this proof-of-concept demonstration. Electro sprays are ideal for this application since they are able to extract ions and/or nanometer-sized charged droplets from a liquid surface (the propellant) without need of an ionization volume and are also extraordinarily compact and do not require complex propellant management strategies, since they are fed through capillary forces alone.

Electro sprays make use of ionic liquids (room-temperature molten salts) as propellants. Because of their extremely low pressure, these liquids simplify the design of the propellant management system. AF-M315E belongs to a subclass of ionic liquids, with previous work at MIT demonstrating outstanding performance using this propellant in electro spray MEP thrusters.

A key innovation involves the use of AF-M315E as a single propellant that feeds a monopropellant thruster and the MEP. A fundamental advantage of MEP thrusters is their ability to process AF-M315E directly, without vaporizing, heating, catalysis or other energy-intensive chemical or physical processes. The approach involves the design and construction of an in-vacuum propellant loading setup suitable for MEP thrusters.

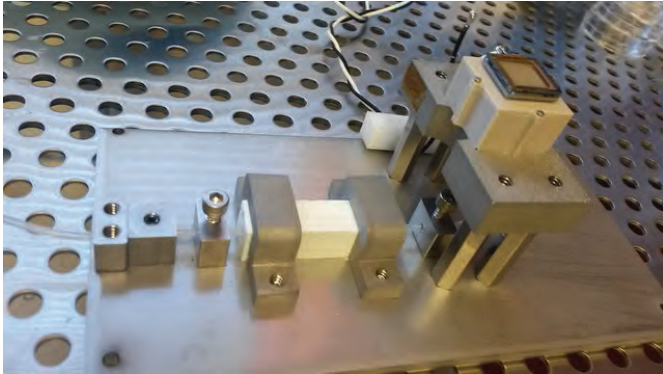

FIGURE 2. MEP thruster and reservoir connected to the venting component (white block in center).

Our team designed a proof-of-concept setup in which the propellant is injected into an MEP thruster in a vacuum environment in the laboratory. The setup takes liquid at a reduced pressure from the main propellant tank and feeds it into the MEP tank, which provides venting of gases into the vacuum chamber. As the liquid outgases, it creates gas pockets that are vented while creating electric isolation from the fluid supply components, thus allowing operation of the MEP system independently of the chemical system. To validate the concept, a test-apparatus was built and tested. The propellant can be observed filling up the tank through a viewport mounted on an MEP tank.

SUMMARY

A proof-of-concept setup for a bimodal chemical-electric propulsion system was built and tested. Preliminary results show that it should be possible to fill up a tank of a microfabricated electro-spray MEP thruster using the green propellant AF-M315E. Future versions of this approach could optimize the propulsion system capabilities of satellites having widely different maneuvering requirements.

PROJECT MANAGERS AND/OR PRINCIPAL

INVESTIGATORS: Kurt Polzin (NASA), John Dankanich (NASA) and Paulo Lozano (Massachusetts Institute of Technology (MIT))

PARTNERSHIP: MIT

FUNDING ORGANIZATION: Cooperative Agreement Notice

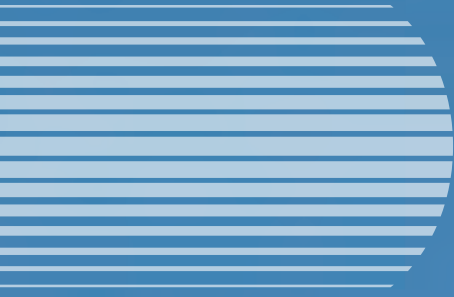



AUTONOMOUS SYSTEMS



In the coming decades, robotics and autonomous systems will continue to change the way space is explored in even more fundamental ways, impacting both human and science exploration. Therefore, the goal of this technology area is to extend our reach into space, expand our access to increasingly distant destinations, and increase our ability to manipulate assets and resources to help us understand planetary bodies using remote and in situ sensors.

Advances in robotic sensing and perception, mobility and manipulation, rendezvous and docking, onboard and ground-based autonomous capabilities, and human-systems integration will drive these goals. Autonomous systems reduce the amount of direct human interaction and supervision time required by the equipment involved in spaceflight, which frees up astronauts to engage in alternative activities or allows space probes to operate more smoothly when at a great distance from Earth.

Smartphone Video Guidance Sensor-Based Navigation of RINGS Onboard the International Space Station

OBJECTIVE: To integrate the smartphone video guidance sensor (SVGS) with the resonant inductive near-field generation systems (RINGS) vehicles in a 3-degrees-of-freedom (3DOF) formation flying demo as precursor to deployment onboard the International Space Station (ISS).

PROJECT DESCRIPTION

The smartphone video guidance sensor (SVGS) packs all the functionality of the advanced video guidance sensor (AVGS) developed by Marshall Space Flight Center (MSFC) in the form factor of a smartphone for use as a 6-degrees-of-freedom (6DOF) rendezvous and docking sensor. The SVGS utilizes a predefined pattern of four retroreflective targets on a target vehicle. The SVGS sensor resides in the form factor of a smartphone

Reorient Experimental Satellite (SPHERES) vehicles, attempted to demonstrate electromagnetic formation flying inside the ISS. RINGS provides actuation by generating electromagnetic fields which would either attract or repel the two vehicles with respect to each other. However, due to difficulties with its navigation approach, RINGS failed in its primary objective. The SVGS is a navigation sensor which had yet to be demonstrated in a closed control loop and the RINGS needed an optical navigation sensor; therefore, this was

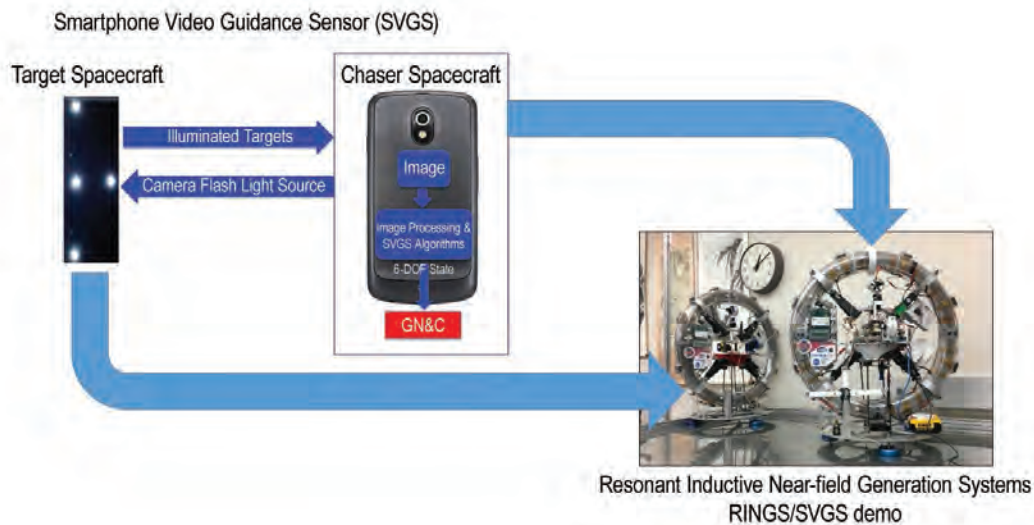

FIGURE 1. SVGS/RINGS integration concept.

residing on the chase vehicle. The smartphone flash illuminates the retroreflective targets. The smartphone camera then acquires an image of the illuminated targets. A software algorithm on the smartphone processes the image to estimate the 6 degrees-of-freedom (6DOF) state between the chase and target vehicles.

The Florida Institute of Technology's (FIT's) resonant inductive near-field generation systems (RINGS) experiment, mounted on Massachusetts Institute of Technology's (MIT's) Synchronized Position Hold Engage and

an excellent synergistic opportunity. The goal of this project was to integrate SVGS with RINGS so that the SVGS would provide adequate optical navigation to accomplish the RINGS objectives. The SVGS/RINGS system would be tested in FIT's flat floor facility to prove 3DOF formation flying of two RINGS vehicles. Successful ground demonstration would prove feasibility for deployment onboard the ISS.

ACCOMPLISHMENTS

Under the purview of a cooperative agreement, MSFC delivered a version of the SVGS software application to FIT. Students at FIT implemented the app on a Nexus-S Android smartphone. The students 3D-printed a structure for the targets and attached retroreflectors on the structure in the positions specified by MSFC. FIT attached the targets to a RINGS air-bearing-mounted vehicle actuated in 3DOF via propulsion from ducted fans. The students mounted the smartphone on a second RINGS vehicle, also mounted on an air bearing and propelled by ducted fans. The students interfaced the SVGS app with the second RINGS vehicle's flight computer via Bluetooth so that SVGS could wirelessly send its 6DOF measurement to the flight computer. The second RINGS vehicle followed the first vehicle around the flat-floor table while students displaced the first vehicle. Thus, closing the feedback control loop around SVGS and performing proximity operations via SVGS was achieved for the very first time.

This project featured many significant accomplishments that met and exceeded the original goals. For the first time, the SVGS was used as the sensor in a feedback control loop for a vehicle. Several different control approaches were evaluated on the SVGS/RINGS system, including proportional-integral-derivative (PID), linear quadratic Gaussian (LQG), and sliding mode controllers. The SVGS was successfully used in a formation flying demo. Two RINGS vehicles used SVGS to maintain a formation in 3DOF on the FIT flat floor. The vehicles demonstrated robustness in maintaining the formation in the presence of dynamical perturbations. SVGS sensor performance was characterized to prove it was good enough to hold the RINGS formation for the electromagnetic formation flying configuration.

SUMMARY

This highly successful project proved SVGS's viability for use by small spacecraft for proximity operations. Formation flying FIT's RINGS vehicles proved to be an excellent application of SVGS. FIT's RINGS vehicles now have an adequate navigation system to complete their original mission on ISS with the SPHERES vehicles. As an Android OS application, SVGS also shows promise as the RINGS navigation sensor for possible integration on the Astrobee vehicle, the successor to SPHERES onboard ISS.

PRINCIPAL INVESTIGATORS: John Rakoczy, Ivan Bertaska, Chris Becker, Ricky Howard

PARTNERSHIPS: Dr. Hector Gutierrez, FIT

FUNDING ORGANIZATION: Cooperative Agreement Notice

Habitat Ground-Based Demonstrator: Auto-Operator for the Autonomous Fluid Transfer System (AFTS)

OBJECTIVE: To develop and demonstrate autonomous systems to serve habitats when crew is not present, provide software tools to reduce the crew’s dependence on ground-based mission control, and demonstrate autonomous systems and operations capabilities, and requirements as a ‘proof of concept.’

PROJECT DESCRIPTION

This project aimed to develop and demonstrate, for the habitat ground-based demonstrator (HGBD), a prototype ‘smart’ vehicle management system (VMS) which performs autonomous planning for a single vehicle subsystem simulated by the autonomous fluid transfer system (AFTS) using the higher active logic (HAL) system as an executive component prototype. The AFTS is a complex, two-fault-tolerant system with heater and recirculation operations as well as autonomous flight and safety rule enforcement. This project demonstrates a vehicle subsystem that is planned, replanned, and controlled autonomously by HAL VMS.

The Timeliner-TLX design for the auto-operator is an attempt to model the original HAL 9000 executive components that could be developed. Since only one small subsystem was to be operated, only three components would be modeled—HAL Main, Safety, and Environmental Control Life Support System (ECLSS) (the system an AFTS would be controlled under). The context diagram shown in figure 1 depicts the Timelin-

er-TLX bundle configuration and the executive functions that are used for plan generation, self-monitoring, and execution.

The AFTS is a simple subsystem with limited devices, so the executives have limited functionality. There are no other subsystems for a mixed-plan convergence (merging of multiple plans). There are limited safety checks to perform and limited rules to verify. The execution component that actually commands the fluid transfers contains embedded fault detection isolation and recovery in each autoprotcedure. This reduces the replan capabilities that would be otherwise needed. This latter point stresses how a smart subsystem reduces the planning requirements overall. It does this by having automatic safing and failover, negating the requirement for replanning in only the cases of permanent failure. The HAL functionality developed for the auto-operator included parts of the HAL Main executive, parts of the Safety executive, and a partial ECLSS executive. The HAL Main executive functions encompassed the initialize sequence that performs a complete software installation of both the executive and

execution components. It also houses the plan monitor that starts activities based upon the current plan held in memory and monitors all activities for execution failures. The Safety Executive functions encompassed the FDDR Monitor—a device-level fault monitor with messaging—and the Plan Monitor that verifies a new plan when requested. The ECLSS executive functions are specific to the AFTS, as no other subsystems were available to

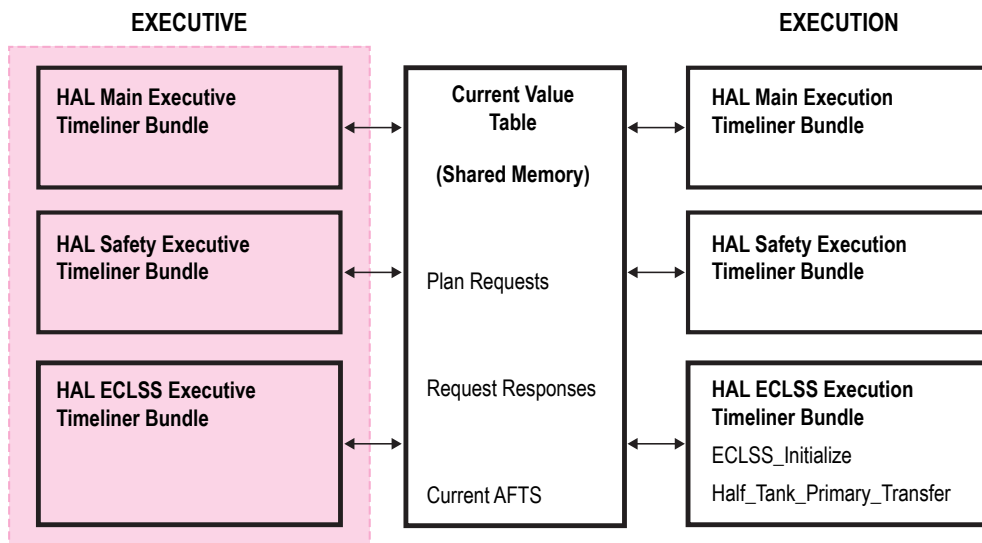

FIGURE 1. Auto-operator context diagram.

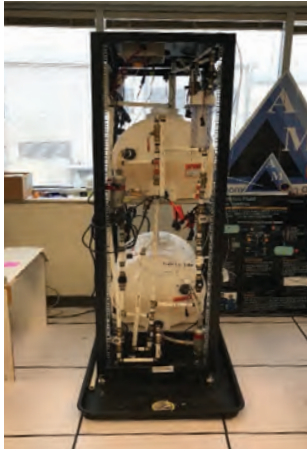

FIGURE 2. Autonomous fluid transfer system.

implement. It encompassed the timeline generator, which generated fluid transfer activities based upon usage and replenish rates, the resource tracker which tracks fluid levels every hour to determine a daily usage and replenish rate, and the convergence sequence which replaces the current time line of fluid transfer activities with the newly approved plan of fluid transfer activities. The AFTS shown in figure 2

was the only target to plan, but other subsystems could be added with separate logic module insertion into the timeline generator that is specific to the subsystem being operated.

ACCOMPLISHMENTS

Only partial executive functions were developed since only one subsystem was involved. The HAL Main executive function, HM_Initialize, establishes an initial usage and replenish rate via crew queries. This sequence becomes active upon installation and installs all the Timeliner-TLX software in the system. The HM_Plan_Monitor sequence is started by the HM_Initialize sequence and immediately verifies if a plan is already in existence. If not, the sequence requests the ECLSS executive to generate a new plan. The sequence then monitors for all fluid transfer activities for ‘stop by error’ conditions. This is necessary because an activity that is no longer functioning can leave the AFTS in an off nominal state. If a fluid transfer activity becomes stopped abnormally, the HM_Plan_Monitor sequence will start the Safety executive’s ‘safing’ sequence because the AFTS may have been transferring fluid when the error occurred with no ability to stop the fluid transfer. The safing sequence ensures the complete AFTS system is in a safe condition by powering off all pumps and closing all valves.

The timeline generation produces a plan of activity records in time order. The activity record format at this time is a simple activity identifier and a pair of time-stamps for activity start time and activity duration. The HAL Main executive’s plan monitor sequence executes the plan that is held in memory. The sample activities first produced are shown in table 1.

ACTIVITY ID	ACTIVITY START TIME	ACTIVITY DURATION
1 (1/4 Tank Transfer)	233:14:31:20	7:27
1 (1/4 Tank Transfer)	234:14:31:25	7:27
1 (1/4 Tank Transfer)	235:14:31:30	7:27

TABLE 1. HAL Main executive sample activities.

The replenish rate and usage rate were set at 5 gal each. The result based on such a low rate produced quarter-tank transfers. Once the usage rate increases to at least 10 gal per day, the timeline generator produces half-tank fluid transfers if the replenish rate can match the usage rate. If the usage rate exceeds 10 gal per day or the replenish rate is less than the usage rate, the timeline generator produces the ‘X gallon’ activity, which queries the crew for the amount of fluid to transfer. The activity durations were initial fluid transfer times based on the preprogrammed quantities and actual use of the primary fluid transfer leg. These durations are determined during autoprocedure test and checkout and become part of the HAL systems knowledge pack data. The duration eventually can be utilized to determine activity time spacing to insure no two activities overlap. Since we had such a slow usage rate and slow transfer rate, activity overlap at 1 transfer per day would never be encountered.

SUMMARY

The HAL 9000 system software design is extremely large, and only a small subset of the capabilities and interfaces are demonstrated in this initial effort. Adding more subsystems to ECLSS would only advance the logic module architecture in the timeline generation sequence. Adding more systems, such as power and communications, would be best for expanding the executive functionality of multiple system timelines and stressing timeline convergence (merging). Adding additional systems would require additional development of automated activities for these systems so that planning functionality could be developed. As systems are added, the modularity of the design can be realized, as each subsystem and device within the system will have its own embedded operations knowledge as well as the logic to plan the operations.

PROJECT MANAGERS AND/OR PRINCIPAL INVESTIGATORS: Angie Haddock and Howard Stetson
FUNDING ORGANIZATION: Technology Investment Program

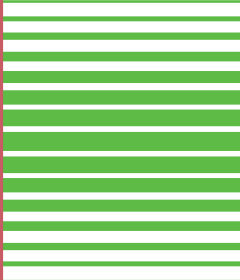

COMMUNICATION AND NAVIGATION



NASA's space communications and navigation infrastructure provides the critical lifeline for all space missions. It is the means of transferring commands, spacecraft telemetry, mission data, and voice for human exploration missions, while maintaining accurate timing and providing navigation support. Advancements in communications and navigation technologies will allow future

missions to implement new and more capable science instruments, greatly enhance human missions beyond Earth orbit, and enable entirely new mission concepts. This will lead to more productivity in science and exploration missions, as well as provide high-bandwidth communications links that will enable the public to be a part of NASA's exploration and discovery programs.



Programmable Ultra Lightweight System Adaptable Radio (PULSAR)

OBJECTIVE: To reduce size, weight, and power (SWaP) while increasing telemetry data rate over traditional small radios in the S- and X-band frequency ranges.

PROJECT DESCRIPTION

The Programmable Ultra Lightweight System Adaptable Radio (PULSAR) is a Marshall Space Flight Center (MSFC) transceiver designed for the CubeSat market but has the potential for terrestrial applications as well. PULSAR is a software-defined radio (SDR). The PULSAR S-band communications subsystem is an S- and X-band transponder system, comprised of a receiver/detector (receiver) element, transmitter element(s), and related power distribution, command, control, and telemetry element for operation and information interfaces. It is capable of receiving commands and encoding and transmitting telemetry in a manner compatible with Earth-based ground stations, Near Earth Network (NEN), and Deep Space Network (DSN) station resources. Figure 1 shows PULSAR during electromagnetic interference testing as part of environmental testing.

ACCOMPLISHMENTS

The PULSAR SDR's data format characteristics can be defined and reconfigured prior to launch or during spaceflight. The PULSAR team continues to evolve the SDR to improve the performance and form factor to meet the requirements that the CubeSat market space requires. One of the unique features is the actual radio design's ability to somewhat change without requiring any hardware modifications due to the use of field programmable gate arrays (FPGAs). Another benefit of FPGAs is reduction of size, weight, and power (SWaP) while increasing telemetry data rate over traditional small radios in the S- and X-band frequency ranges. The PULSAR has been through initial environmental testing and one high altitude balloon flight. Figure 2 shows PULSAR packaged for the balloon flight.

On June 1, 2017, a high-altitude weather balloon flight was launched from the parking lot of the National Space Science Technology Center (NSSTC) with PULSAR as the payload. The purpose of the balloon flight was to test the PULSAR SDR over long distances and 'near-space' conditions. The ground station was located on the roof of the NSSTC and was comprised of the NASA PULSAR team and a support team from GATR Technologies, Inc. GATR provided one of their inflatable tracking antennas for this test. The balloon and chase team were members of High Altitude Research Corporation (HARC). HARC provided the balloon, coordination with the FAA, the tracking data, and the recovery of the payload. Data was received on both S- and X-bands. Additionally, the uplink was tested

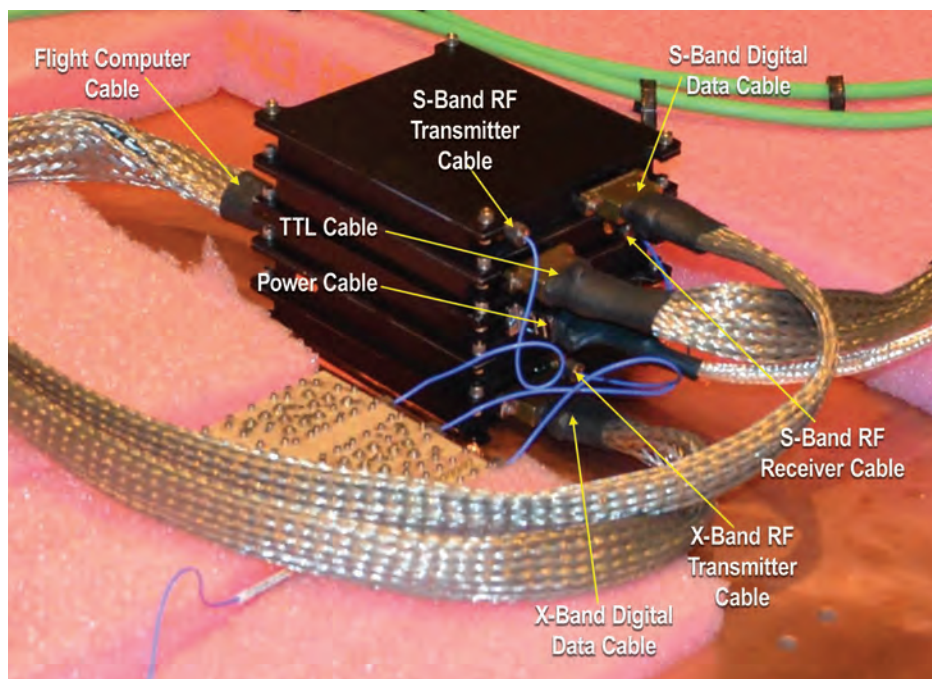

FIGURE 1. PULSAR in the EMI lab.



FIGURE 2. Balloon payload with PULSAR underneath plate.

successfully by sending a command to invert the data being transmitted. The balloon burst at 90,000 ft, as predicted, and allowed the payload to descend via parachute in near Stevenson in Northeast Alabama.

SUMMARY

PULSAR continues to evaluate the ground data generated during the balloon flight. Performance improvements are being planned for the next version of PULSAR. An evaluation review will look at the environmental testing that has been performed along with the performance of the balloon flight to guide the future direction of the PULSAR effort.

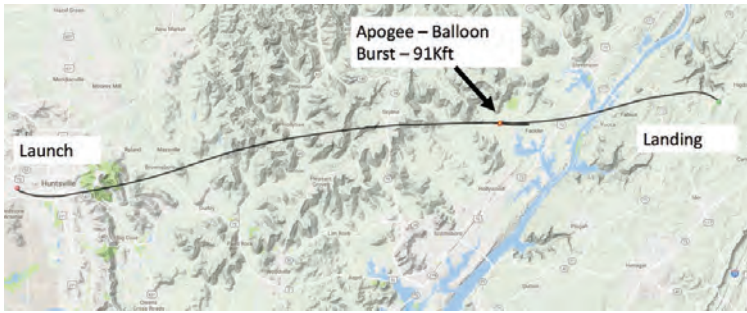

FIGURE 3. Balloon flight path over North Alabama.

PRINCIPAL INVESTIGATORS: Herb Sims and Kosta Varnavas

PROJECT MANAGER: Arthur Werkheiser

PARTNERSHIP: GATR Inc.

FUNDING ORGANIZATION: Game Changing Development



FIGURE 4. High-altitude balloon launch from NSSTC.



Mars Ascent Navigation

OBJECTIVE: To develop simulation models and tools to assess sensitivities and to develop support requirements for navigation systems, both optical and inertial, for a human Mars Ascent Vehicle (MAV) to aid state initialization and ascent operations.

PROJECT DESCRIPTION

Much work has been done on the architecture development for a large-payload Mars Ascent Vehicle (MAV). These studies have focused on overall mass to orbit, propulsion systems design, and trajectory design for a notional vehicle. There has not been a detailed assessment of the guidance, navigation, and control (GNC) components required to meet mission requirements. This project intends to address that gap and lay the groundwork for detailed analysis. A Martian craft must be capable of autonomous operations to support initial determination of its launch attitude and location, which are some of the fundamental drivers to insertion accuracy, bounding how well the vehicle can attain a desired orbit. The focus of this work is to apply knowledge in Earth-based launch vehicle GNC to a Martian scenario to provide insight into the capabilities afforded

by state-of-the-art systems. This helps to identify long lead hardware items and potential risks. The goal of this project is to develop a modeling and simulation environment in order to assess the navigation system. In order to accomplish this, generic inertial navigation unit models will be integrated into a simulation framework to assess navigation accuracy over a variety of ascent trajectories. This is intended to capture launch site sensitivities and cover the wide breadth of potential landing sites, with a focus on how the navigation accuracy affects vehicle sizing in terms of propellant required for on-orbit trajectory corrections.

In addition to inertial navigation, this study will capture the capabilities and feasibility of using optical systems on the Martian system to support initialization and in-flight activities. This research seeks an advantage of star-tracker-based navigation methods that are in development to support state determination on Earth in GPS-denied regions. By assessing and understanding the requirement of the navigation architecture, this study will identify possible applications of optical navigation and identify any potential mission constraints that are required for them to operate. This will be achieved through documentation of the usage of optical navigation on existing planetary rovers and proposed usages within the terrestrial domain. These capabilities will then also be assessed using the modeling and simulation environment to define their benefits to a Mars ascent navigation architecture.

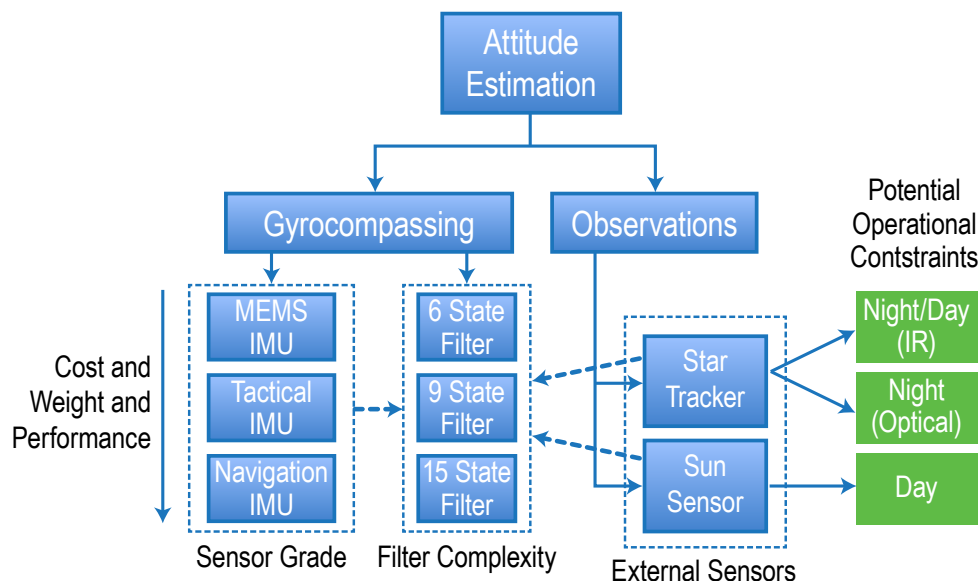

FIGURE 1. Attitude estimation options.

ACCOMPLISHMENTS

This research effort takes advantage of the team’s expertise in ascent navigation architectures for terrestrial vehicles. It is also transposing those tools into a modular environment for assessment for a wide breadth of planetary missions. This framework includes generic inertial-measurement unit sensor errors terms to enable modeling and simulation of a range of capabilities from micro-electromechanical system (MEMS)-grade to navigation-grade sensors. Additionally, implementation within a modular environment allows for options in quickly trading initialization algorithms (gyrocompassing), inertial navigation, and environment models, such as gravity. The results of analysis within this framework will support sensor trade studies and requirement development. Additionally, these tools enable the need for optical navigation techniques and their potential benefits.

This research collaborated with the current MAV architecture team as the base point for analyzing an ascent trajectory. Initial study results provided this effort with a notional mass budget, propulsion capabilities, and in-space mission design. The team then developed a series of ascent trajectories using the POST ascent trajectory design tool to model a variety of launch sites.

As part of this research effort, a variety of options for inertial attitude alignment have been implemented into a common framework within a generic inertial navigation unit model to allow for rapid analysis. The various trades for initial attitude determination are identified in figure 1. Figure 2 captures the additional trades for understanding the vehicle’s initial position on the Mars surface. The generic model allows for generation of on-pad dynamics on the Mars surface (allowing for future inclusion of wind modeling and vehicle twist and sway motion), gyrocompassing, and inertial navigation through ascent. This tool allows for sensitivity analysis from sensor specifications to algorithm selection to insertion accuracy.

An additional tool was designed to analyze the effort of navigation accuracy on the MAV’s requirement to rendezvous with a transfer stage in order to return to

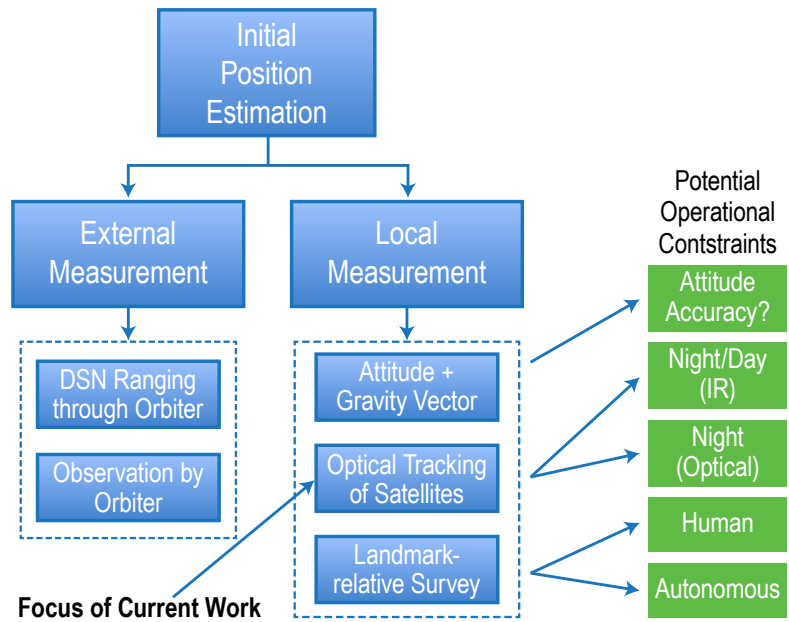

FIGURE 2. Position initialization options.

Earth. A custom input deck was developed within the Copernicus trajectory optimization tool to reoptimize mission burns in order to meet rendezvous conditions. This links the navigation insertion accuracy to the changes in propellant required to ensure mission success.

SUMMARY

These tools are integrated into one simulation framework to allow for end-to-end analysis to enable assessment and documentation of the systems performance and requirements. The models will be used to document and support MAV navigation system design trades and to help identify potential long lead items and risks to mission success. With this environment in place, it will allow for additional detail into system performance assessment and can be wrapped into full GNC simulations of the vehicle design. Similarly, this work will help to identify areas of opportunity for optical navigation in planetary ascent vehicles, providing rationale for continued studies into their application and capabilities.

PROJECT MANAGER AND/OR PRINCIPAL INVESTIGATOR: Evan Anzalone, NASA MSFC

PARTNERSHIP: MAV project

FUNDING ORGANIZATION: Technology Investment Program





LIFE SUPPORT AND ENVIRONMENTAL MONITORING



For future crewed missions beyond low-Earth orbit (LEO) and into the solar system, regular resupply of consumables and emergency or quick-return options will not be feasible. Also, spacecraft will experience a more challenging radiation environment in deep space than in LEO. Therefore, the technologies in this section focus on developing technologies that enable long-duration, deep-

space human exploration with minimal resupply of consumables and increased independence from Earth, while maintaining permissible space radiation exposure limits. Specifically, the following projects, developed at Marshall Space Flight Center, are working to transition partially closed life support systems to more fully closed-loop integrated systems.



Ionic Liquids (ILs) Enabling Revolutionary Closed-Loop Life Support

OBJECTIVE: To develop a fully regenerable oxygen recovery technology using ionic liquids to extract, produce, and regenerate catalyst materials.

PROJECT DESCRIPTION

Currently on the International Space Station (ISS), the oxygen recovery system recovers approximately 50% of the oxygen from metabolic carbon dioxide (CO_2). For future long-duration manned missions, 75% oxygen recovery is the minimum targeted requirement, with a goal of greater than 90%. A promising technology for achieving higher oxygen recovery rates is the Bosch

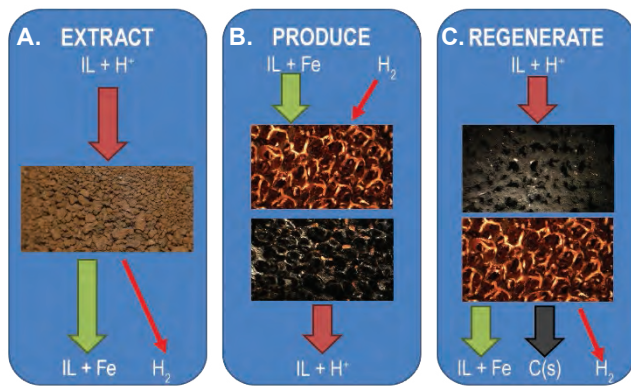

FIGURE 1. A designed IL is used (a) to extract iron from surface regolith, (b) produce a catalyst for the Bosch process by electroplating iron onto a copper substrate (center), and (c) regenerate carbon-fouled catalyst extracting the iron from the copper substrate (right).

process, which can theoretically achieve 100% oxygen recovery. The main concern with the Bosch process is the formation of elemental carbon that ultimately fouls the catalyst. Fouling of the catalyst compromises the performance of the reaction, requiring the catalyst to be replaced and resulting in undesired resupply mass. The Bosch process accumulates carbon at a rate of approximately 1.2 kg (2.6 lb) per day. For a 3-yr Mars mission, the carbon accumulation would require approximately 1,315 kg (2,850 lb) of catalyst resupply. The elimination of catalyst resupply can be achieved with a fully regenerable ionic liquid (IL)-based Bosch system that employs in situ Martian resources. An IL is used to extract

catalytic iron from an in situ source, such as regolith. A catalyst material is produced using the IL and a substrate, such as copper. Following oxygen recovery and carbon production, the IL is used to regenerate the substrate and the iron catalyst. The goal of this project is to develop a Bosch-based technology that uses ILs to recycle system catalyst while providing a clean method of handling product carbon. In FY2017, the objectives of the effort included generation of the data necessary to scale the proposed technology and generation of an advanced system concept and design.

ACCOMPLISHMENTS

The IL-based Bosch system involves three critical steps (fig. 2). In step 1, the catalyst is prepared by electrolytically depositing iron on copper substrates in a reactor (A). The hydrogen gas required for this step is provided by a metal hydride storage container (B). Step 2 is carbon formation (D) in which dioxide (O_2) is recovered from carbon dioxide, resulting in carbon coated catalyst substrates. Step 3 is regeneration of the carbon-coated catalyst (E). Hydrogen gas is produced in this step and stored in a metal hydride (G). Once iron and carbon have been removed from the reactor, the carbon is filtered out of the IL (H). The same IL is used in both step

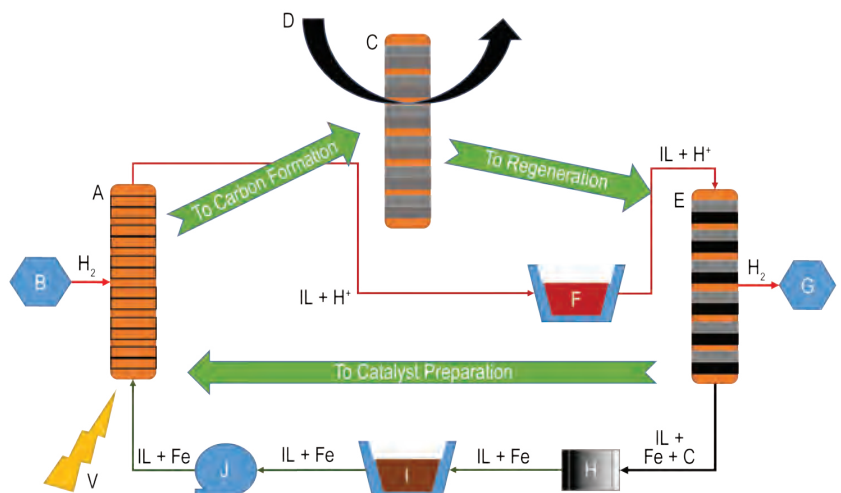

FIGURE 2. IL-based Bosch system concept.

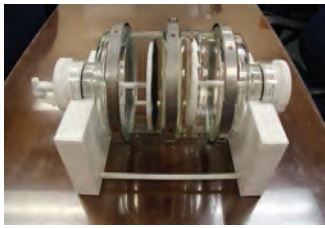

FIGURE 3. Multisubstrate generation chamber.

1 and step 3. Once step 3 is complete, both the iron and copper substrates are reused repeatedly throughout the process. The only consumable in the process is the carbon filter; however, partially regenerable filtration is intended.

Although there are various other Bosch-based systems that are currently being researched, no other system proposes zero catalyst resupply mass with a simplified approach to carbon handling. If successful, this approach represents a complete paradigm shift with respect to closed-loop life support technology.

Significant progress was made toward maturing the IL-based Bosch technology. Catalyst preparation was scaled from single- to multisubstrate preparation through the design of a multigeneration chamber, (fig. 3) allowing for the simultaneous plating of seven substrates (fig. 4). Kinetic data on the catalyst material was generated to support scale-up of the reactor to a 1-crew member (CM) size. The resulting reactor was demonstrated up to a scale of 2.1-CM (the limitation of the test stand, not necessarily the reactor) and 75% single-pass conversion efficiency. Regeneration of the carbon-coated substrates was explored using various approaches. While an optimized design for substrate regeneration was not identified, considerable progress was made toward this end. Finally, new IL-based Bosch reactor design and system design concepts were generated.

SUMMARY

An IL-based Bosch system approach will provide a fully regenerable technique for recovering oxygen from either metabolic carbon dioxide or from atmospheric carbon dioxide by utilizing ILs and in situ resources. Past studies proved the feasibility of such system and provided a first generation IL-based Bosch system concept. Iron was successfully electroplated onto copper substrates, all electroplated copper substrates were shown to be catalytic from all sources, and iron extraction from a high-carbon-content mixture using an IL was demonstrated. Progress in FY2017 included scaling up of the technology that is required for an integrated life support system, as well as an initial reactor design and concept for an IL-based Bosch system. A multisubstrate plating apparatus and a bulk regeneration system was designed, constructed, and successfully tested. Kinetic data was obtained, and a 2.1 crew member reactor was demonstrated. Based on the data gathered throughout the study, a reactor design and second-generation concept was generated. Future work will involve further optimization of the bulk regeneration system that mimics the design of the IL Bosch-based reactor design which enhances the carbon cleaning capabilities. Also, a high-efficiency filter system to remove the carbon from the IL should be further investigated to ensure long-term robustness of the IL. The construction of the IL Bosch-based reactor is anticipated in FY2018.

PROJECT MANAGERS AND/OR PRINCIPAL INVESTIGATORS: Brittany Brown and Eric Fox

FUNDING ORGANIZATIONS: Center Innovation Fund; Advanced Exploration Systems

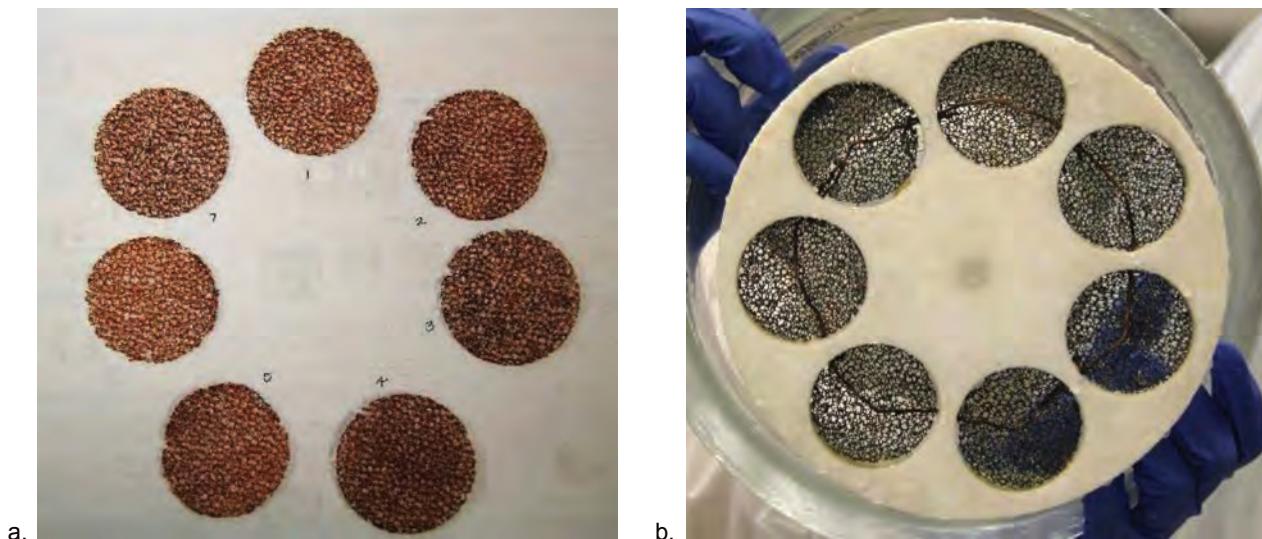

FIGURE 4. Copper substrates (a) prior to electroplating and (b) after electroplating with iron.

Series-Bosch Oxygen Recovery Mix and Match Evaluations

OBJECTIVE: To evaluate a number of catalytic carbon formation reactors to increase the maturity of a Series Bosch (S-Bosch) system for recovering and recycling up to 100% of the oxygen from the carbon dioxide exhaled by astronauts living in space.

PROJECT DESCRIPTION

Manned missions beyond low Earth orbit will require highly robust, reliable, and maintainable life support systems that maximize recycling of water and oxygen. Bosch technology is one option to maximize dioxide (O_2) recovery, in the form of water, from metabolically-produced carbon dioxide (CO_2). A two-stage approach to Bosch, called Series-Bosch, reduces metabolic carbon dioxide with hydrogen (H_2) to produce water and solid carbon utilizing a reverse water-gas shift (RWGS) reactor, a carbon formation (CF) reactor and two gas separation membranes. The S-Bosch is an attractive option for oxygen recovery as it can theoretically recover 100% of the oxygen from carbon dioxide.

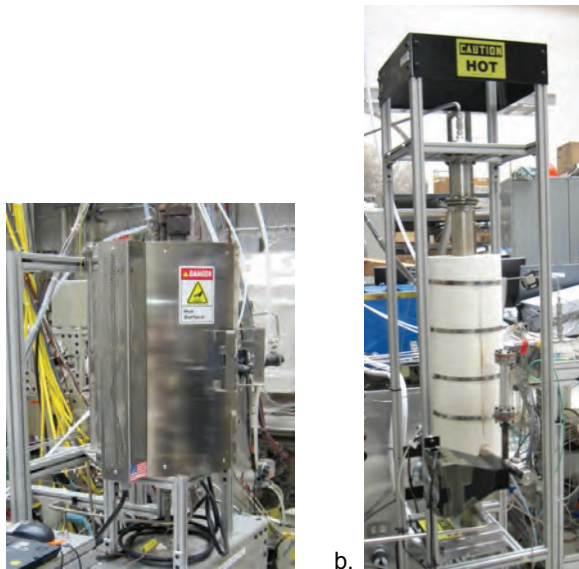

FIGURE 1. Integrated into the CORTS are the (a) pH matter reactor and (b) UMPQUA reactor.

Through the Space Technology Mission Directorate's (STMD's) Next Generation Life Support (NGLS) project and under the spacecraft oxygen recovery (SCOR) task, alternative technologies are being developed to

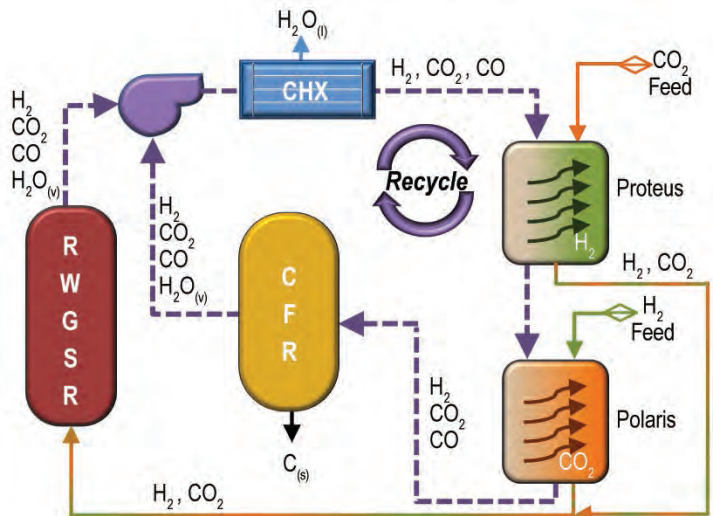

FIGURE 2. Illustration of the S-Bosch system as it appears in the CORTS.

advance oxygen recovery technologies. Contracts were awarded to four companies in FY2015. Two of the awardees were pH Matter, LLC, and UMPQUA Research Company. These contracts each produced hardware to address the carbon formation reactor component of the in S-Bosch system.

ACCOMPLISHMENTS

NASA's Carbon Dioxide Reduction Test Stand (CORTS) is a facility capability that allows for modular-based component and subsystem-level testing for closed-loop life support. This approach allows NASA the flexibility to test numerous configurations of oxygen recovery technologies. Last year, pH Matter and UMPQUA Research Company each delivered reactors to NASA for independent evaluation. Previous testing in the CORTS with a RWGS reactor, membrane separators, and an in-house, NASA-developed carbon formation reactor provided the baseline of compari-



son for subsequent tests involving the pH Matter and UMPQUA reactors. NASA is evaluating the performance of these reactors with the goal of down-selecting the most promising technology combination among several carbon formation reactors. Data gained from the evaluations will be used along with power consumption, volume, mass, crew time, and carbon removal capabilities to determine a final selection. The selected reactor will undergo further development to accomplish 75% or better oxygen recovery in the S-Bosch system.

Integration and initial testing of the pH Matter reactor was completed in the Summer of 2017, while integration and initial testing of the UMPQUA Research Company's reactor began late in Fall 2017. Testing of the UMPQUA reactor continued through the end of 2017.

SUMMARY

Future long-duration missions require systems that are closed-loop to eliminate the need to resupply water and oxygen. The S-Bosch system has the potential to meet this requirement by recovering up to 100% of the oxygen from expired carbon dioxide.

PROJECT MANAGERS AND/OR PRINCIPAL

INVESTIGATORS: Morgan Abney and Christine Stanley

PARTNERSHIPS: pH Matter, LLC, UMPQUA Research Company

FUNDING ORGANIZATION: Advanced Exploration Systems



FIGURE 3. A sample of carbon produced in the pH Matter Carbon Formation Reactor. The carbon formed as very fragile flakes with specks of catalyst intersperse within the flakes.

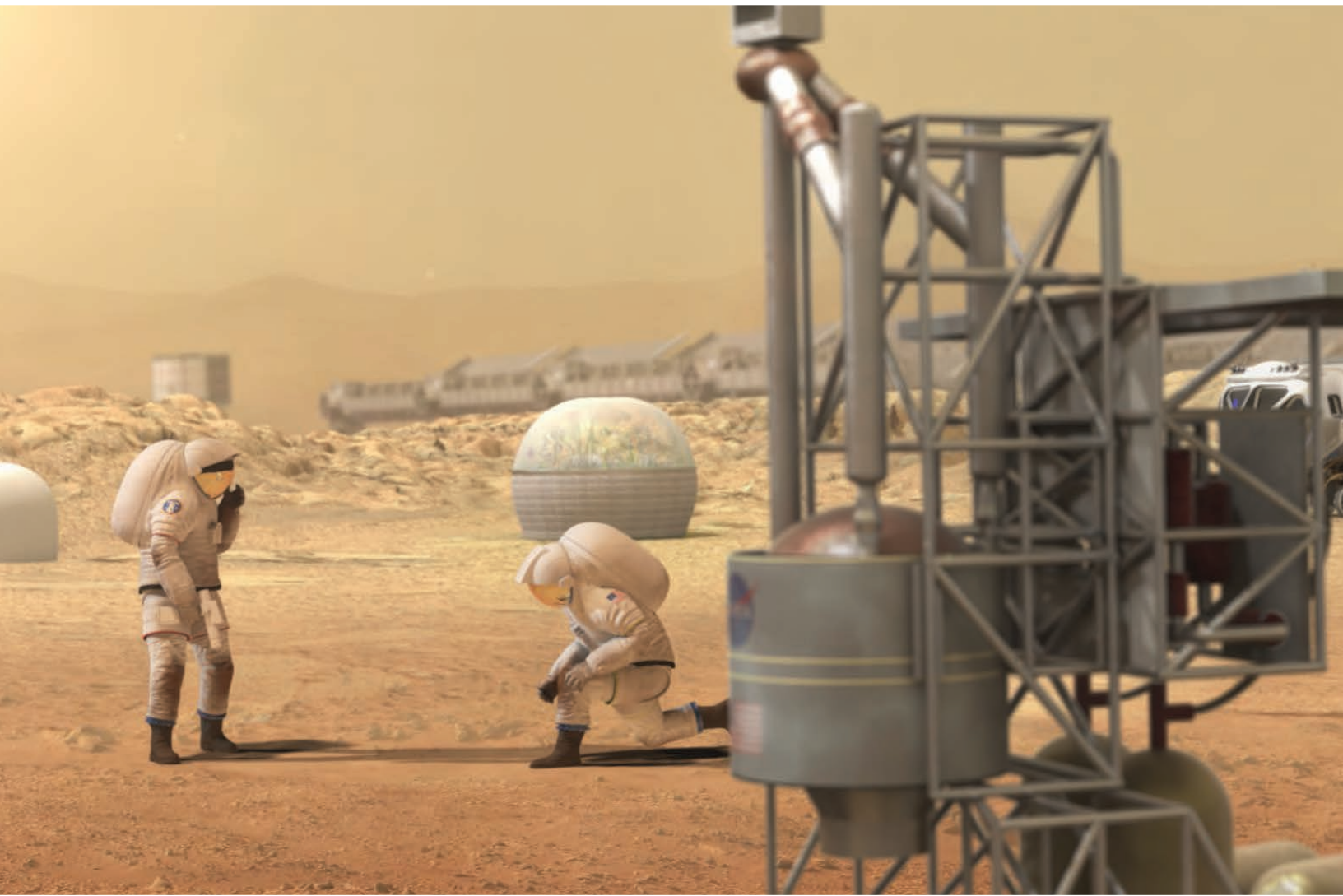



IN SITU RESOURCE UTILIZATION

The goals related to this technology area involve sustaining human presence in space, which will require existing systems and vehicles to become more independent, incorporate intelligent autonomous operations, and take advantage of the local resources. Advances must be made in finding, extracting, and processing in situ resources. The reliability of all mission systems—especially habitation components—must be improved, and all systems must

be easier to maintain or repair. Human crews must have more time available for performing core mission activities and spend less time maintaining systems or managing logistics. Crews must also be less reliant on ground operations support and must conduct more training during the mission. The technologies discussed in this section are designed to extract useful materials from the planetary environment for use as fuels, building materials, life support materials, etc.



In Situ Production of Cementitious Material from Martian Resources

OBJECTIVE: To produce binding material from regolith and for regolith to maximize the use of in situ resources for additive construction on planetary surfaces.

PROJECT DESCRIPTION

To help make sustainable planetary surface missions economically feasible, NASA is investigating a 3D printing process for structures called additive construction. Additive construction of infrastructure elements on planetary surfaces—such as habitats, roads, garages, and berms—will require a lot of material. Ideally, the construction material will be mined from the planetary surface and not brought from Earth. This project involves extracting binder material from available planetary resources that, when combined with regolith, will provide a construction material that is compatible with additive construction technologies. The binder under study is sodium silicate (Na_2SiO_3), also known as water glass. After combining an aqueous solution of sodium silicate with regolith aggregates, water can be extracted and reused for future building events. This project also employs ionic liquids (ILs) as dissolution media; these catalyst-like ILs can be regenerated for further use during processing of the sodium silicate binder.

aqueous IL, with accompanied regeneration of the IL. Combining the sodium hydroxide with the silica gel produced earlier in the dissolution process will create a solution of sodium silicate binder. The binder will then be mixed with regolith aggregate and cured to produce a building material. Ultimately, this building material will be tested for use in additive construction technology.

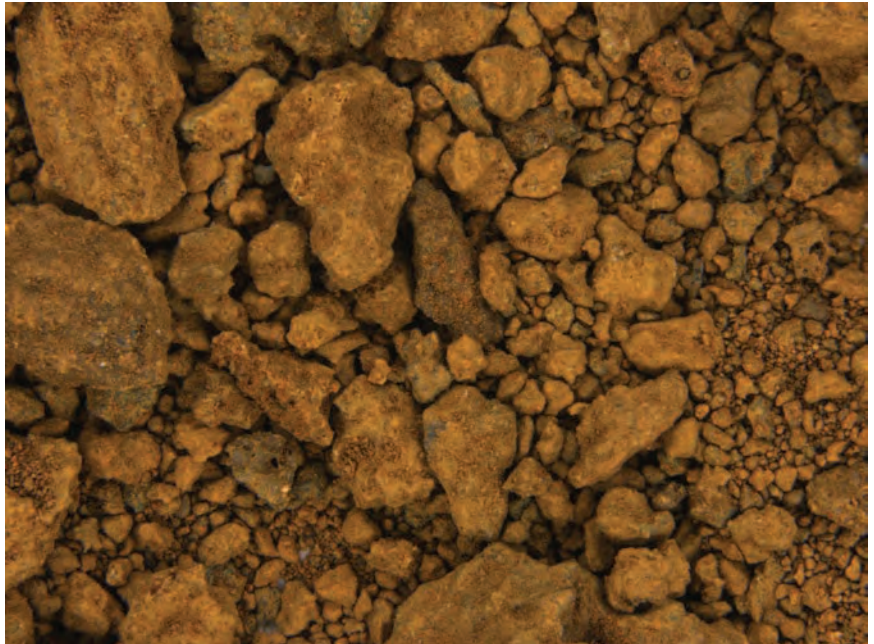
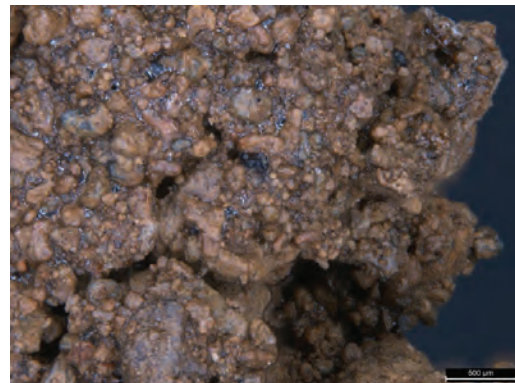

FIGURE 1. Images of Johnson Space Center Mars-1A simulant. The image below shows the simulant bound with sodium silicate. Images provided by Dr. Richard Grugel.

ACCOMPLISHMENTS

Sodium silicate can be created by mixing solutions of sodium hydroxide (NaOH) and silica (SiO_2) gel. This mixture will react to form sodium silicate and water. Regolith can then be mixed with the Sodium silicate solution, and the water can be removed (and recycled) to form structures. The fabrication of the binder material will begin with ILs, which are organic salts. Aqueous solutions of acidic ILs will dissolve planetary regolith simulant, solubilizing metallic cations (such as sodium) and leaving insoluble silica, as a gel, behind. Sodium hydroxide will be produced by electrolytic hydrolysis of the sodium dissolved in the



Traditional production of sodium silicate involves two processes. The first is baking sodium carbonate (Na_2CO_3) with silica sand at temperatures between 1,000 °C and 1,400 °C. Not only is this method energy-intensive, it releases the greenhouse gas carbon dioxide (CO_2). By using ILs, which only require a small amount of heat to dissolve the sodium-rich phases (less than 200 °C), the energy required to extract sodium is significantly less. Additionally, phases other than sodium carbonate can be used, thus eliminating the carbon dioxide byproduct of the process. The other traditional manufacturing process for sodium silicate involves the production of sodium hydroxide from sodium sulfate (Na_2SO_4), which ultimately produces sulfuric acid. ILs can mine sodium and silica from silicate phases (e.g., the minerals albite and sodium bentonite), thus eliminating the production of sulfuric acid in the creation of sodium silicate.

The sodium-rich minerals albite and sodium bentonite (montmorillonite), known to exist on the surface of Mars, were selected for dissolution experiments. Albite is a feldspar—a sodium aluminosilicate—and is one of the most difficult minerals to dissolve. Montmorillonite is a clay that has a similar elemental makeup to albite but a crystal structure that incorporates water, if available. Montmorillonite expands, which also makes it more likely than albite to dissolve. Three ILs and sulfuric acid (a control) were used to dissolve the minerals. Preliminary results indicate one IL may dissolve the minerals almost as well as the sulfuric acid once processing temperatures are optimized.

Initial experiments to combine sodium silicate solution with simulated regolith and solidify the mixture were completed. Figure 2 shows the first brick produced under this study. The mixture was microwaved to evolve the water and encourage crystallization of the sodium silicate to bind the simulant into a solid form. Year 2 of this work will involve optimizing the mixture for use in additive construction and removing the water from the sodium silicate solution/simulant mixture to produce stronger construction materials.



FIGURE 2. First sodium silicate Mars brick. Photo provided by Dr. Richard Grugel.

SUMMARY

Production of construction materials from in situ resources is a gamechanger for NASA. This work will provide fundamental research into the production and printing of construction materials on planetary surfaces. Removing the need to fly construction materials to planetary surfaces by producing them in situ will significantly reduce mission cost and provide the ability to build infrastructure elements on demand. Additionally, this method of producing sodium silicate using ILs, without much energy, emitting carbon dioxide, or creating sulfuric acid, would be useful to the water glass industry on Earth. Because ILs have a very low vapor pressure, thus low flammability, they are safer and easier to handle than conventional chemical reagents.

PROJECT MANAGERS AND/OR PRINCIPAL

INVESTIGATORS: John Fikes, Mallory Johnston, Eric Fox, and Jennifer Edmunson

PARTNERSHIPS: University of Mississippi, Dr. Hunain Alkhateb, Department of Civil Engineering

FUNDING ORGANIZATION: Center Innovation Fund

Purification of Lunar Cold-Trapped Volatiles

OBJECTIVE: To separate volatiles extracted from the permanently shadowed regions (PSRs) of the Moon for use in propulsion, life support, and other necessary systems for sustainable crewed missions.

PROJECT DESCRIPTION

Many types of technologies have been proposed for volatile extraction in the permanently shadowed regions (PSRs) of the Moon, but none go beyond the collection of the mixed volatiles. The goal of this work is to take the extracted volatiles and separate them into usable materials. This process involves a cascade of task-specific organic salts, known as ionic liquids (ILs). The volatiles will flow through mists of ILs that will each grab a specific volatile. This project is focusing on carbon monoxide (CO), ammonia (NH₃), and sulfur dioxide (SO₂) volatiles known to exist in the PSRs from the Lunar Crater Observation and Sensing Satellite (LCROSS) mission. Subsequent processing of each IL will allow the separated gases to be obtained for use.

ACCOMPLISHMENTS

Traditionally, individual volatile species are obtained from a gaseous state by the introduction of a cold trap. However, given the volatile species present in the LCROSS results (except water), a series of cold traps, each at different temperatures, will not work to separate the volatiles because they have overlapping solidification temperature ranges. In addition, as they cool down, some of the volatiles can react with each other to form nonvolatile compounds; e.g., ammonia, can react with hydrogen sulfide (H₂S) to form the salt ammonium hydrosulfide (NH₄⁺SH⁻). Thus, additional separation techniques are needed.

A workable solution is to have a cascade of task-specific ILs that are designed to extract specific volatile species from a mixture of volatiles. For example, acidic ILs can extract bases such as ammonia, and alkaline ILs can extract acids such as sulfur dioxide (SO₂). The process in work uses cryogenic trapping to remove H₂O prior to purification of other volatiles using task-specific IL mists. Misting of the ILs in this process provides greater surface area with which the mixed volatiles can interact, increasing the chemisorption of the volatile of interest. The volatiles chosen for this experiment show

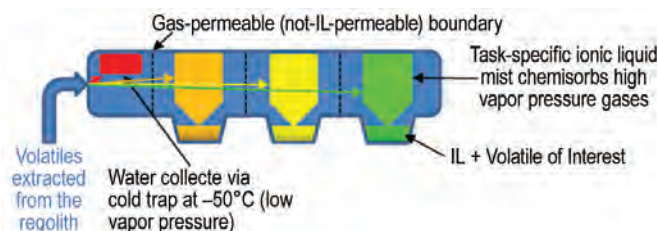

FIGURE 1. Concept of cascade hardware to separate volatiles extracted from lunar PSRs.

a range in IL capabilities in that they capture basic ammonia, neutral carbon monoxide, and acidic sulfur dioxide.

In year 1 of the Center Innovation Fund work, task-specific ILs were identified for gases carbon monoxide, ammonia, and sulfur dioxide; efficiency of absorption is under quantification. Year 2 activities will include building and testing the cascade hardware (concept shown in fig. 1), as well as testing the extraction of volatiles by each IL in the cascade using mixed gases.

Gas bottles with low concentrations (less than 1%) of each volatile species were purchased. A balance (scale) was modified to protect components from any possible corrosion via an argon backflow into the electronics compartment and a new balance pan created out of unreactive IL epoxy carbon composite. Specific ILs were identified and tested for extraction; quantifying the efficiency of the process is still underway.

Despite the supposedly low concentrations of ammonia and sulfur dioxide in the purchased gases, the ammonia and sulfur dioxide are reacting at room temperature to form ammonium sulfites as observed during experimentation in figure 2. (The type of ammonium sulfite formed depends on temperature and the molar ratios of ammonia and sulfur dioxide in the gas.) This will have implications for testing mixed gas streams in year 2. Testing with lower concentrations of ammonia and sulfur dioxide will take place to see if concentrations closer to lunar PSRs (0.33 and 0.18 wt%, respectively) will prevent the two gases from reacting when evolved.

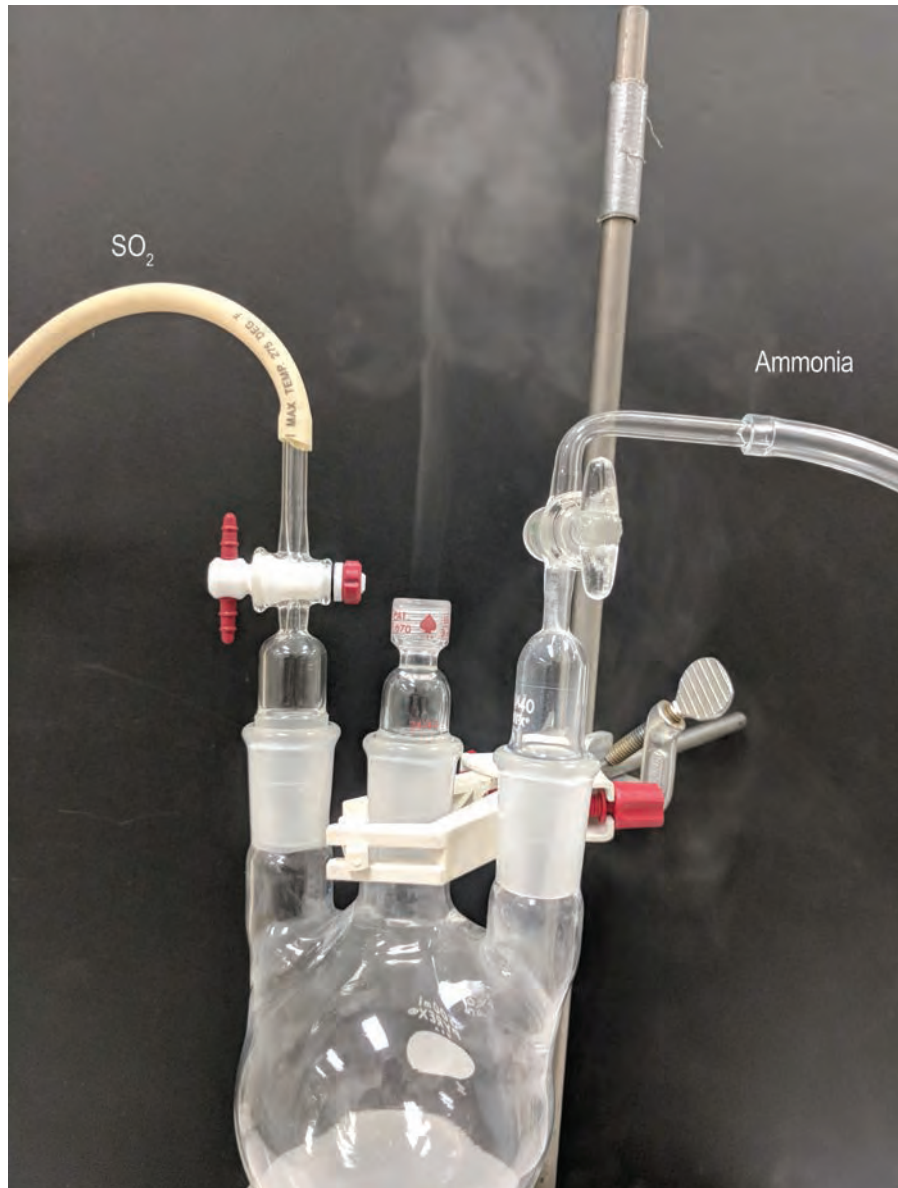

FIGURE 2. Reaction between ammonia and sulfur dioxide producing solids observed as 'smoke.' Photo by Dr. W. Kaukler.

Cooling the system with liquid nitrogen (LN_2) to obtain a temperature closer to that on the Moon may also keep the two volatiles from reacting. As there are methods for mitigating this reaction, it is not expected to affect results.

SUMMARY

Any resource that can be mined from a planetary surface is one less that has to be flown from Earth. Thus, production of purified volatiles from lunar resources is of significant value to NASA. The target outcomes of this 2-year effort are hardware that can separate PSR volatile species and three task-specific ILs that can

be used with the same mixture of gases with each IL designed to extract a different volatile species from the mixed gas. This work is innovative in that it provides a workable way to separate the PSR volatiles after collection and sequester them for later recovery and use as propellants, in life support, or in additive manufacturing and construction.

PROJECT MANAGERS AND/OR PRINCIPAL INVESTIGATORS: Kevin DePew, Eric Fox, and Jennifer Edmunson

FUNDING ORGANIZATION: Center Innovation Fund

Ionic Liquid (IL) Metals and Oxygen Extraction in Microgravity: A Prelude to Asteroid Mining

OBJECTIVE: To design a hardware prototype for an International Space Station (ISS) experiment demonstrating electroplating of metals from meteoritic sources.

PROJECT DESCRIPTION

Exploration within the solar system and beyond will require making use of the resources that are at the destination site, or ‘living off the Land,’ as America’s first pioneers did. Task-specific ionic liquids (ILs) can be used in a large variety of ways to enable NASA’s exploration missions. One of these uses is for the extraction of metals and oxygen from lunar, planetary, or asteroid soils, using an environmentally safe IL. The oxygen in the soil reacts with the hydrogen in the IL acid to make water, and the metals are dissolved, forming soluble salts. The water is then electrolyzed to form oxygen and hydrogen. The oxygen can be used for life support or propellant and in a further step, the hydrogen is used to regenerate the IL to dissolve more soil and to also plate out the metals and use them for manufacturing of spare parts. Mining asteroids for their resources will require methods that will work under very low gravity conditions, so it is necessary to test whether it is possible to perform the same methods used on Earth within the low-gravity environment of the ISS. The goal of this project is to develop test hardware for this purpose.

The cost to launch all required supplies for life support and further manned travel to worlds beyond Earth’s Moon would be prohibitive without using resources available along the way and at the destination. Asteroids, our Moon, and other planets and moons can provide a wealth of resources, but we need to learn how to efficiently extract them and process them into necessary materials. Electrochemical extractive processes have a number of advantages. In past projects, we have demonstrated molten oxide electrolysis of lunar simulant as a method of extracting oxygen, iron and silicon, but this process requires operating temperatures of 1,500–1,700 °C. Using ILs as the electrolyte, we can achieve extraction at 200 °C or less. ILs are a class of organic salts that are liquid at room temperature and can be made task-specific to perform the work that nearly any conventional chemical can, without the vapors and fumes that are often associated with chemical reactions. Because they have no vapor pressure, they work in the high vacuum of space without evaporating, and they also work at much lower temperatures, thus saving energy. Moreover, for this project,

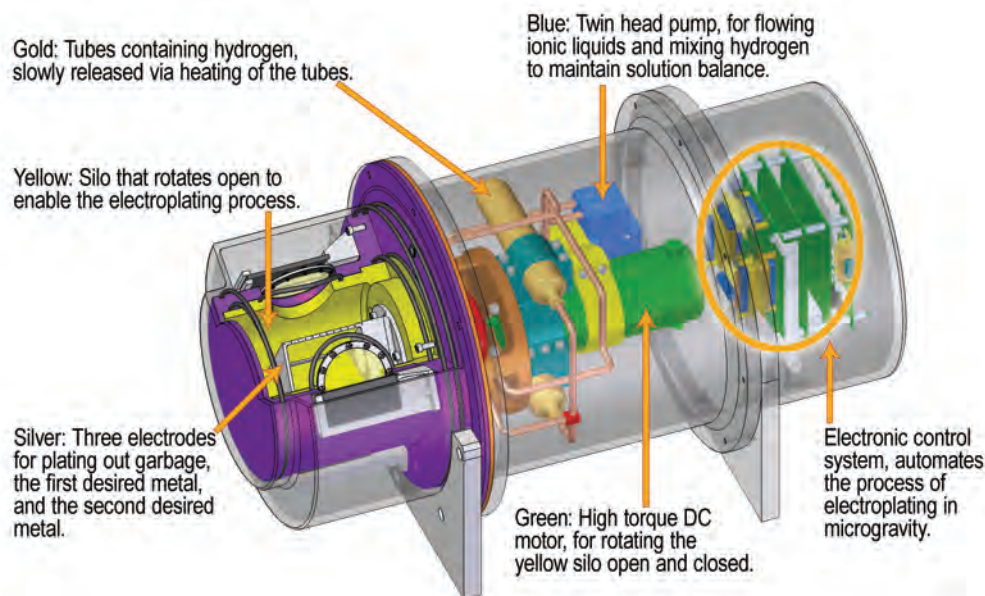

FIGURE 1. Electroplating system overview.

the ILs are regenerable and can be reused many times, thus cutting launch costs. The processes used in this project can also be used on Earth. A couple of ways would be to mine for rare, costly metals available in small quantities and recycling costly metals after use.

Our team has demonstrated a three-step process using an IL that can extract up to 80% of the metal and oxygen from asteroidal and regolith simulant materials. The acidic IL used in this process is depleted of acid during the plating process. We have developed a method to reprotonate the IL from biproducts of the plating reaction. This method makes the IL almost 100% recoverable. The process can then be repeated to extract and plate further asteroidal materials without resupply from Earth.

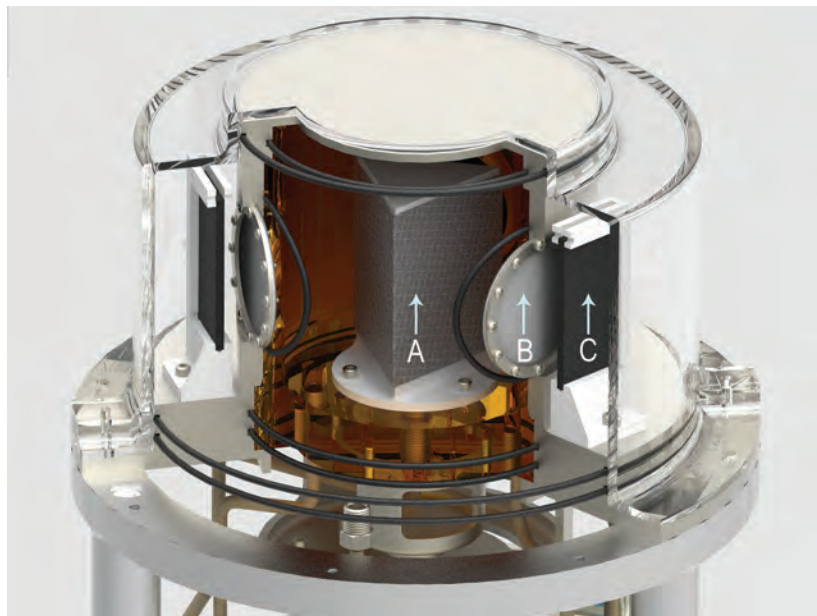

FIGURE 2. Engineering design unit. A: Platinum anode. B: Ion exchange membrane. C: Glassy carbon cathode.

ACCOMPLISHMENTS

A general design for the electrolysis cell had been envisioned, but engineering expertise was required to add more detail and then manufacture a 3D replica. This physical model gave us better insight into the apparatus design and what kind of materials would be desirable to use in a flight experiment. A variety of materials have been tested for compatibility with the chemicals and conditions that will be involved with a flight. We then proceeded to complete the preliminary design of the flight and engineering design units. We developed the cost and schedule for production of an International Space Station flight unit. The detailed design of the of the engineering design unit (EDU) was completed. This included 3D computer models and 19 engineering drawings. These were used to fabricate the components of the EDU. The electrical control system has been designed and prototyped. The components including commercial-off-the-shelf (COTS) parts have been delivered. The EDU is in the process of being tested and assembled. The experiments to test sequential electroplating are in progress, preparing the way for the full up system test of the apparatus.

SUMMARY

There is much excitement today about extracting the space resources and utilizing them for exploration, commerce, and settlement in space. Yet almost no experiments in in situ resource utilization have been accomplished in space. This is because of the expense, complexity, and high energy requirements of the extractive methods proposed. In this project, we have demonstrated a low-energy, safe and simple method to test the extraction of resources from asteroid materials in microgravity. IL electrolysis can enable the construction of a small, affordable device to test the extraction of metals and oxygen from asteroid materials in the ISS.

PROJECT MANAGERS AND/OR PRINCIPAL INVESTIGATORS: Keven Depew, Peter Curreri, and Eric Fox

PARTNERSHIPS: Mercer University, Matt Marone, Department of Physics; University of Minnesota, Matthew Regalman, Department of Electrical Engineering; David Donovan and Steven Paley, ESSSA; Gary Thornton and Max Vankeuren, MSFC Engineering.

FUNDING ORGANIZATION: Technology Investment Program

Additive Construction With Mobile Emplacement (ACME)

OBJECTIVE: To advance additive construction technologies that enable deep-space exploration architectures and improve life on Earth.

PROJECT DESCRIPTION

Additive construction with mobile emplacement (ACME) is the process of excavating and utilizing in situ materials for the construction of large-scale structures like habitats, berms, landing pads, and roads using an autonomous, additive layering technique, often referred to as 3D printing, for the protection of people, hardware, and electronics while on the surface of an extraterrestrial body.

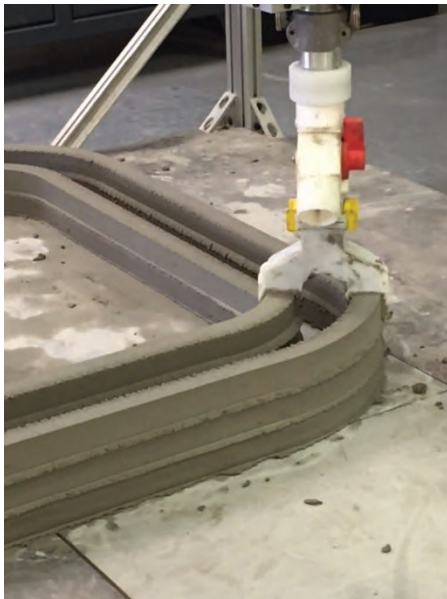

FIGURE 1. Multilayered wall built with multi-outlet nozzle.

For space missions, by using in situ materials, the mass launched from Earth to a destination could be reduced by as much as 60–90%. ACME is focused on developing the technologies required to excavate, sort, and process in situ materials into construction materials. ACME consists of subsystems that process, mix, and continuously feed concrete material through a nozzle mounted on a mobility system. Along with advancing the additive construction process, material research and development is underway to characterize materials, develop new binders, and understand different mixture compositions that could be compatible with the additive construction process. The U.S. Army Corps of Engi-

neers (USACE) is very interested in terrestrial applications of the additive construction technique to reduce building time, material cost, and personnel exposure in hazardous environments. Structures built using this process could aid in quickly and efficiently providing defense protection and accommodations overseas, building emergency housing after a disaster, and utilizing native materials in more remote areas.

ACCOMPLISHMENTS

The ACME project successfully demonstrated the ability to build straight and curved walls using a concrete recipe composed largely of Portland cement, a less expensive testing material that could potentially be created using lunar regolith. Developing binders from in situ resources that are compatible with in situ aggregates to meet process and structure requirements is one of the greatest challenges facing in-space construction. Material research and development is underway to characterize materials, develop new binders, and understand different mixture compositions. Current testing includes hypervelocity impact tests, compression strength tests, and simulated environment curing tests. Research includes incorporating Mars regolith simulant into recipes and characterizing its effects as an aggregate.

Through an interagency agreement, NASA and the USACE are collaborating to advance the additive construction process. The Automated Construction of Expeditionary Structures (ACES-3) gantry system will enable structures to be built within 1/8-in accuracy using six or less people in under 24 hr.

Kennedy Space Center (KSC) provided the material delivery systems. These subsystems measure and supply the needed dry ingredients (e.g. cement, aggregate, sand) and liquid materials (e.g. water, additives) to a mixer. The wet concrete mix is then transferred to the gantry system. Marshall Space Flight Center (MSFC) provided the gantry system that allows for x-, y-, and z-translational movement and Z-rotation of the



FIGURE 2. The ACES-3 gantry system designed and built by MSFC provides mobility.

printhead. Along with providing mobility, the gantry system contains a concrete pump and accumulator that provides a continuous flow of concrete during the build process and allows the flow to be momentarily halted to create doors and windows. The gantry system was sized to autonomously manufacture a 32×16×10 ft tall structure using less than six individuals in 24 hr or less.

SUMMARY

The vision of ACME is to enable science and human exploration by utilizing in situ resources that feed additive construction technologies to efficiently build needed infrastructure. For space missions, by using in situ materials, the mass launched from Earth to a destination could be reduced by as much as 60–90%, saving cost. Additive construction can be used to build both terrestrial and extraterrestrial structures, reduce the time and cost required to transport materials by using in situ materials, and reduce waste as compared to traditional construction techniques.

PROJECT MANAGERS AND/OR PRINCIPAL INVESTIGATORS: John Fikes, Mallory Johnston, Deputy
PARTNERSHIPS: KSC, USACE
FUNDING ORGANIZATION: Game Changing Development

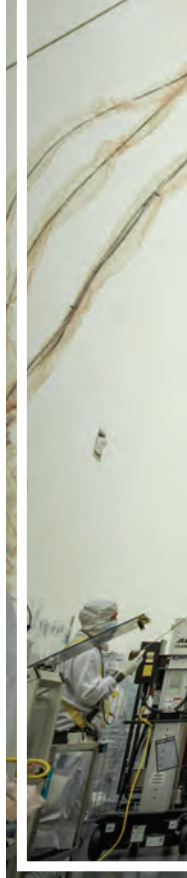

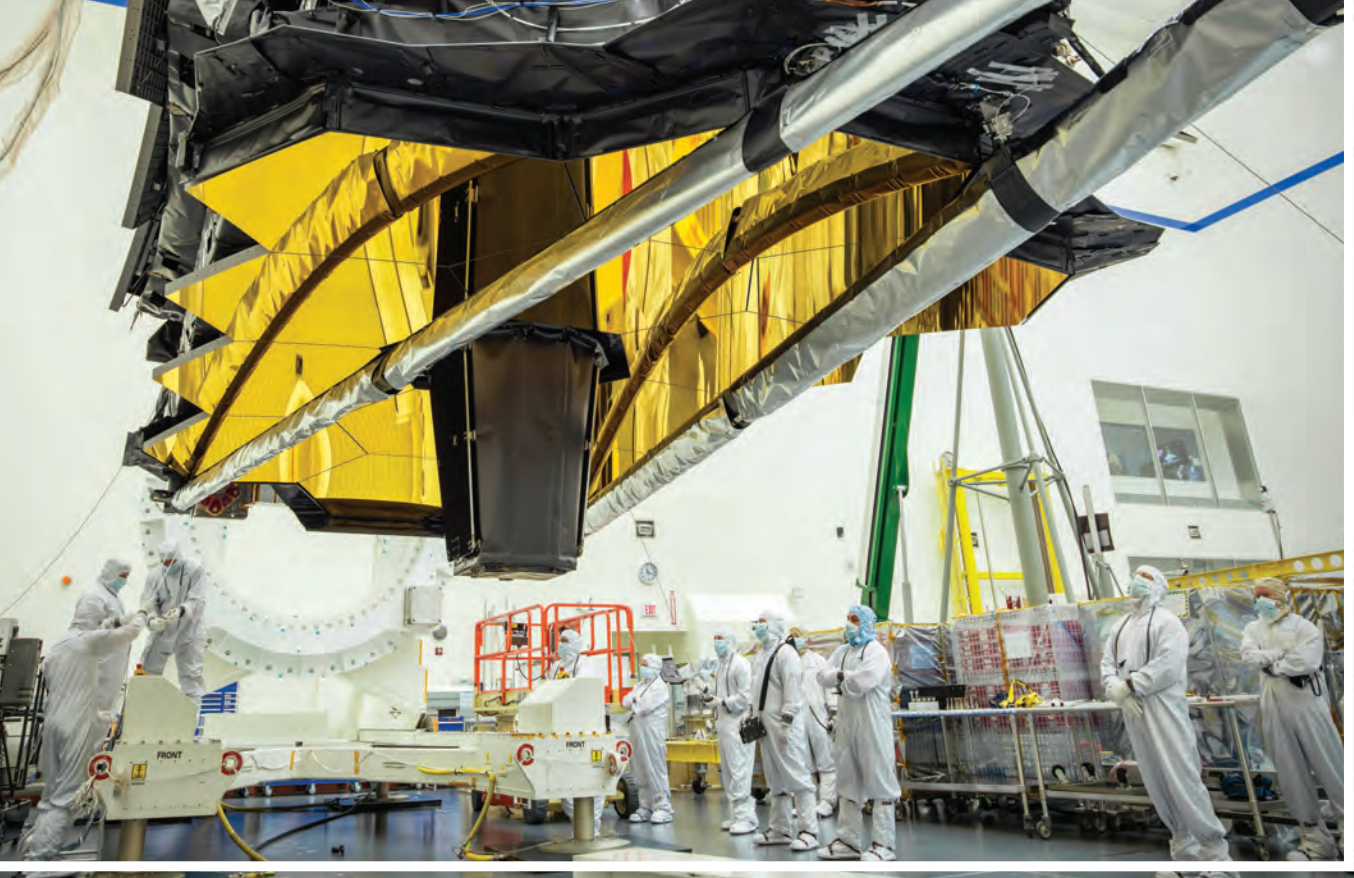

SCIENCE INSTRUMENTS

The technologies profiled in this Science section showcase Marshall Space Flight Center's expertise in atmospheric and space science. These instruments allow information to be gathered about Earth's atmosphere, space, and other planets, most of which is translated into direct benefits for people around the world through

precipitation monitoring, tropical cyclone monitoring, lightning tracking, and solar flare analysis. Each one of these projects has collected valuable information about our solar system or our planet, emphasizing the value of collecting scientific data in order to track storms and increase the productivity and safety of Earth's inhabitants.



Advanced Microwave Precipitation Radiometer (AMPR)

OBJECTIVE: To provide calibrated measurements of the Earth's atmospheric and surface characteristics from an airborne platform.

PROJECT DESCRIPTION

The advanced microwave precipitation radiometer (AMPR) is an airborne, polarimetric, passive microwave radiometer producing brightness temperatures (T_B) at 10.7, 19.35, 37.1, and 85.5 GHz. These frequencies are sensitive to the emission and scattering of precipitation-size ice, liquid water, and water vapor. AMPR is thus able to provide information on surface and atmospheric parameters including precipitation over ocean and land surfaces, cloud liquid water, and atmospheric water vapor over the ocean, ocean surface temperature, and near-surface wind speed, soil moisture, and sea ice. AMPR is a cross-track scanning radiometer, and its polarization basis varies as a function of scan angle. In order to retrieve geophysical information, the calibrated horizontally (H) and vertically (V) polarized microwave T_B values need to be determined. This is accomplished by deconvoluting polarization-variable measurements from two orthogonal channels per frequency. This process must be carefully designed, as there must also be correction for instrument-related T_B offsets between each frequency's channels, as well as corrections for additional offsets caused by scan angle dependencies. Once that is accomplished, then retrieval algorithms need to be developed and tested against validation datasets. During 2017, the AMPR team has been addressing the T_B calibration process and developing empirical retrieval algorithms for geophysical parameters such as cloud liquid water, atmospheric water vapor, and ocean-surface wind speed.

ACCOMPLISHMENTS

One of the tools used for calibration of AMPR is the rooftop sky test, where the instrument is pointed skyward, and the measured cold background T_B of the sky is checked against theoretical calculations. In order to understand scan-angle-related calibration offsets better, we developed a novel addition to the AMPR instrument cart that allows the instrument itself to rotate in azimuth, independent of its scanning splash plate mirror (fig. 1). This enables measurement and subsequent correction of calibration offsets at each scan angle.

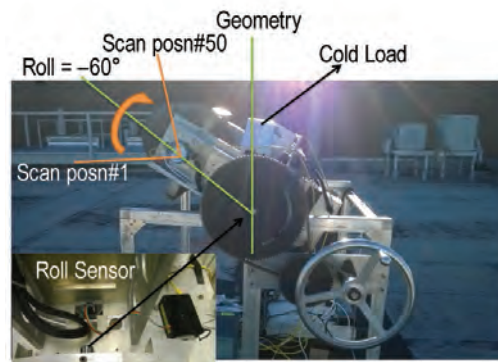

FIGURE 1. AMPR instrument in cart modified to rotate the instrument independently of azimuthal scan angle. Note the hand crank to accomplish the rotation. AMPR is rotated 60° from zenith, with scan range shown.

Once AMPR data were properly calibrated, empirically based retrieval algorithms for cloud liquid water, atmospheric water vapor, and ocean-surface wind speed were developed by using atmospheric and radiative transfer models to simulate polarimetric T_B values associated with these geophysical parameters at different AMPR frequencies. The measurements provided by the new algorithms were then compared against a physically based retrieval algorithm developed for the Global Precipitation Measurement (GPM) mission, as well as validation datasets obtained during the Olympic Mountain Experiment (OLYMPEX) in 2015.

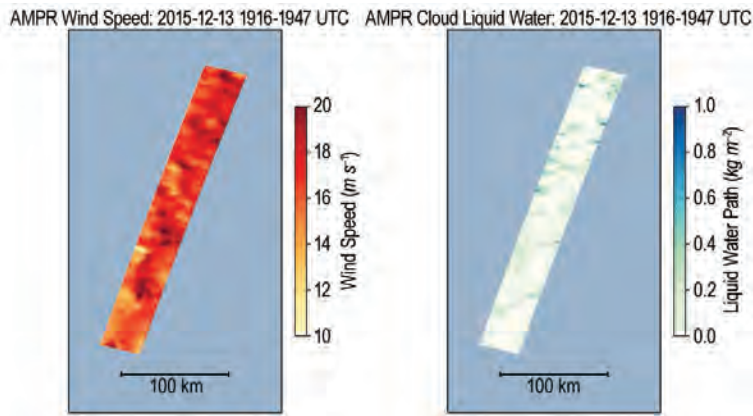

FIGURE 2. Left: AMPR retrieved ocean surface wind speed for 1916–1947 UTC on December 13, 2015. Right: AMPR retrieved cloud liquid water for the same period. Note the small-scale spatial variability in wind speed outside of the cloudy regions.

Based on the results of the sky tests and other calibration activities, scan-angle-dependent and other offsets were reduced significantly, to $<1\text{--}2\text{ K}$ on average for each polarization and frequency. This enabled application of the empirical retrieval algorithms to the OLYMPEX dataset.

Figure 2 shows an example from December 13, 2015. This day featured a lot of scattered post-frontal convective clouds. AMPR winds show realistic small-scale variability near these clouds, suggesting the influence of convectively driven gust fronts. Comparisons with in situ winds from OLYMPEX dropsondes showed agreement within $1\text{--}2\text{ m s}^{-1}$, similar to other remote sensing methods. Cloud liquid water estimates agreed with physically based GPM retrieval algorithms to within $\approx 0.1\text{ kg m}^{-2}$, matching the theoretical performance of the AMPR algorithm. Water vapor retrievals had greater error and showed some remaining cross-track biases. We are planning further improvements to the AMPR calibration and retrieval algorithms as part of our upcoming participation in the Cloud, Aerosol, and Monsoon Processes Philippines Experiment (CAMP2Ex) in 2018.

SUMMARY

In 2017, significant improvements were made to the AMPR calibration process. This enabled accurate retrievals of geophysical parameters associated with the Earth’s atmosphere and surface. This will greatly improve AMPR’s science impact in past, present, and future field campaigns.

PRINCIPAL INVESTIGATOR: Timothy J. Lang

PARTNERSHIPS: University of Alabama in Huntsville, Universities Space Research Association

FUNDING ORGANIZATION: Science Mission Directorate

FOR MORE INFORMATION: <https://weather.msfc.nasa.gov/ampr/>

CLASP2: The Chromospheric Layer Spectropolarimeter

OBJECTIVE: To probe the complex physical conditions and magnetic field of the Sun's chromosphere, while advancing the state of the art in ultraviolet spectropolarimetry.

PROJECT DESCRIPTION

A major remaining challenge for heliophysics is to decipher the magnetic structure of the solar atmosphere, particularly in the complex layer known as the chromosphere. Routine satellite measurements of the chromospheric magnetic field will dramatically improve our understanding of the chromosphere and its connection to the rest of the solar atmosphere and solar wind. Probing the magnetic nature of the chromosphere, however, requires measurement of the Stokes I, Q, U, and V profiles of relevant spectral lines (of which Q, U, and V encode the magnetic field information). Many of the magnetically sensitive lines formed in this part of the solar atmosphere are in the ultraviolet spectrum, necessitating observations above the absorbing terrestrial atmosphere. The Chromospheric Layer Spectropolarimeter (CLASP) measurements, therefore, are made by lofting the instrument on a sounding rocket, and it is hoped that a future incarnation of CLASP will be carried long term on a satellite.

ACCOMPLISHMENTS

Before such a satellite can be considered for flight, it is necessary to refine the measurement techniques by exploring candidate emission lines with a range of magnetic sensitivities. In September 2015, CLASP achieved the first measurement of the linear polarization produced by scattering processes in a far ultraviolet (UV) resonance line (hydrogen Lyman-alpha), and the first exploration of the magnetic field in quiet regions of the chromosphere-corona transition region. These measurements are a vital first step. Nonetheless, Lyman-alpha is only one of the magnetically sensitive spectral lines in the UV spectrum; the Mg II h and k spectral lines near 280 nm are also a compelling target because they are sensitive to a larger range of field strengths than Lyman-alpha. Therefore, the reflight mission, named CLASP2, will refit the existing CLASP

instrument to measure all four Stokes parameters near 280 nm to study wavelength-dependent variations in polarization caused by the joint action of scattering processes and magnetic effects. CLASP2 has been selected for flight in 2019.

During 2017, the CLASP2 project successfully completed its mission initiation conference, requirements definition phase, and design review. Furthermore, CLASP2 accomplished characterization of its science cameras' response at the specific UV wavelength of interest and performed improvements to the cameras that yielded major increases in the usable range and spatial uniformity, of the cameras' sensitivity. Integration and testing will take place in Japan throughout 2018.

SUMMARY

CLASP2 is a reflight of the successful CLASP sounding rocket and is a partnership between Marshall Space Flight Center (MSFC), National Astronomical Observatory of Japan (NAOJ), and numerous others. The instrument upgrades will extend our measurement sensitivity to a wider range of magnetic fields in the chromosphere and mark the path forward to routine satellite measurement of magnetic fields in the Sun's atmosphere. CLASP2 is on track for flight in 2019.

PRINCIPAL INVESTIGATOR: David McKenzie

PROJECT MANAGER: Anthony Guillory

PARTNERSHIPS: NAOJ; Japan Aerospace Exploration Agency; Instituto de Astrofísica de Canarias; Institut d'Astrophysique Spatiale; University of Oslo; Istituto Ricerche Solari Locarno; Stockholms Universitet; Academy of Sciences of the Czech Republic; Lockheed Martin Solar & Astrophysics Laboratory

FUNDING ORGANIZATION: Science Mission Directorate

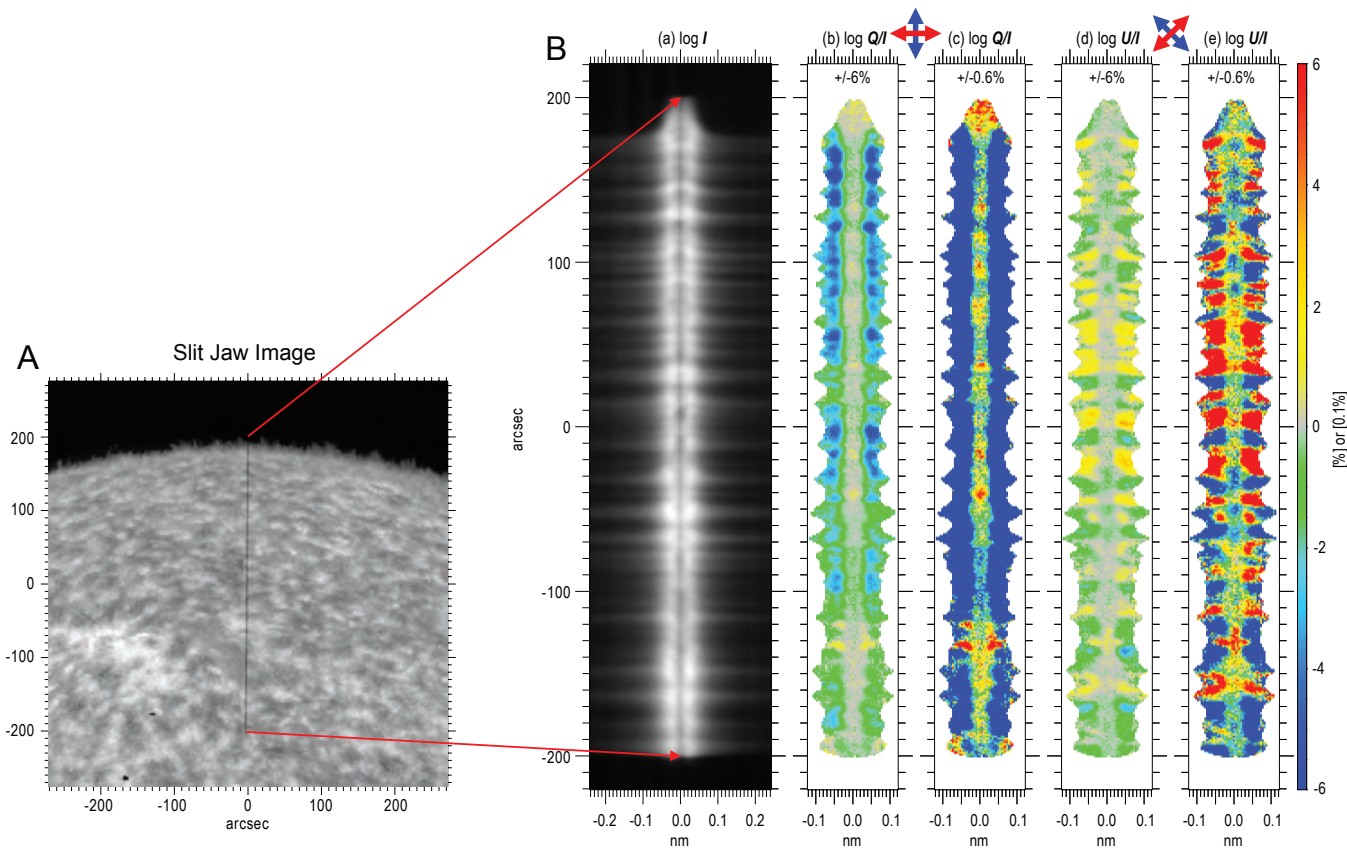

FIGURE 1. Left: A Lyman-alpha image taken by the CLASP slitjaw camera. Right: The Stokes I, Q/I, and U/I profiles along the CLASP slit direction. The Q/I wings show a clear center-to-limb variation, from $\approx 5\%$ close to the solar limb to $\approx 1\%$ near the disk center.

Fly's Eye Geostationary Lightning Mapper Simulator (FEGS)

OBJECTIVE: To develop an airborne array of multi-spectral radiometers to observe lightning in thunderstorms.

PROJECT DESCRIPTION

With the successful launch to orbit of the GOES-16 satellite, the Geostationary Lightning Mapper (GLM) is providing continuous data characterizing optical emission from lightning in thunderstorms over the full Earth disk. Because GLM is a new remote sensing technology, a large validation effort is underway to characterize the instrument performance. As part of that validation effort, the Fly's Eye GLM Simulator (FEGS) has been developed at Marshall Space Flight Center (MSFC). FEGS is an airborne array of multispectral radiometers optimized to study the optical emission from lightning from high-altitude aircraft. With spatial and temporal resolution exceeding that of GLM, FEGS can resolve the rapid optical processes that contribute to a lightning event detected from space. This capability will allow scientists at MSFC and collaborating institutions to scrutinize the type of events that GLM detects, in contrast to those that it does not, and help to determine the detection efficiency and sensitivity of GLM. Beyond the validation study, FEGS adds the capability to investigate submillisecond lightning energetics to the NASA Airborne Science Program.

ACCOMPLISHMENTS

FEGS constitutes a significant advancement in remote sensing technology for observing lightning optical emission from aircraft. While previous airborne campaigns included one or two radiometers to observe thunderstorms, FEGS carries 30 radiometers whose individual field-of-view combine to create an image of the cloud top at a rate of 100,000 times per second, six spectral channels, and an HD camera to provide detailed images of the cloud top. The increased number of radiometers on FEGS allows scientists to retrieve more accurate measurement of the power and energy emitted by the lightning discharge and to characterize spatial nonuniformity of the light propagation through the cloud.

To maximize the science opportunity of the mission, FEGS was flown with a complimentary suite of instruments called the Airborne Lightning Observatory for FEGS and TGFs (ALOFT). Terrestrial gamma-ray flashes (TGFs) are gamma-ray and high-energy particle emission from thunderstorms. The ALOFT package includes a two-channel electric field derivative antenna to characterize the physical processes occurring in the cloud and two sets of gamma-ray scintillators to detect TGFs. When flown with FEGS, the ALOFT package adds the capability to investigate lightning energetics spanning from radio frequencies to gamma-ray emission to the NASA Airborne Science Program.

FEGS was designed, constructed, and calibrated at the National Space Science and Technology Center (NSSTC) in Huntsville, Alabama. In Spring 2017, FEGS was flown as a primary payload on the NASA ER-2 high-altitude laboratory as part of the GOES-R validation flight campaign. Eleven flights were conducted with FEGS as the primary instrument, totaling 45 hr of thunderstorm observations over a variety of thunderstorm phenomenologies including coastal, oceanic, and continental thunderstorms; convective initiation; low- and high-flash-rate storms across the continental US during both day and night. Over 7,000 lightning flashes were detected during those flights, a remarkably successful collection that increases the airborne lightning dataset by a factor of ten above previous missions.

Preliminary analysis of the FEGS dataset is underway and suggests that GLM is exceeding its performance specifications on orbit. Characterization of GLM's detection efficiency and how it varies for different storm types or time of day is ongoing and will play roll in how forecasters at the National Weather Service interpret the data product produced by GLM for severe weather forecasting and situational awareness.

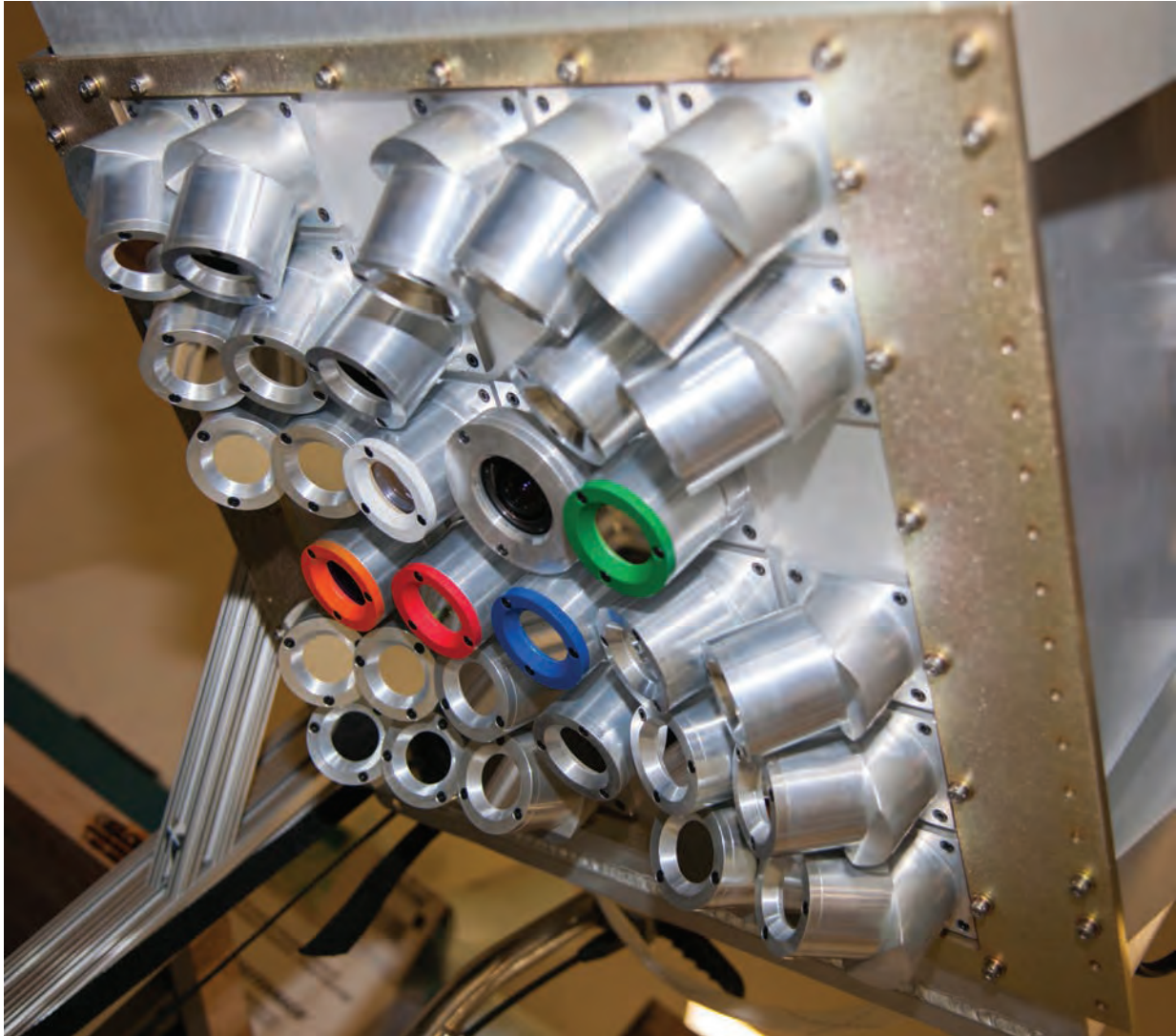

FIGURE 1. A photograph of the assembled FEGS radiometer array. Radiometers with colored caps indicate the channels with alternate spectral filters. The large aperture fixture near the center is a wide-angle HD camera to provide contextual images of the cloud top.

SUMMARY

Ongoing analysis of the FEGS dataset collected in Spring 2017 for the GOES-R validation flight campaign to help determine the sensitivity and detection efficiency of GLM. This unique dataset will also be useful to enhance scientific understanding of the physical processes involved in a lightning discharge. FEGS is a new addition to the NASA Airborne Science program and provides a new platform for thunderstorm remote sensing.

PROJECT MANAGERS AND/OR PRINCIPAL INVESTIGATORS: Richard Blakeslee, Mason G. Quick
PARTNERSHIP: University of Alabama Huntsville
FUNDING ORGANIZATION: Science Mission Directorate
FOR MORE INFORMATION: https://www.youtube.com/watch?v=QOZkInI_9r8

Fermi Gamma-Ray Burst Monitor (GBM)

OBJECTIVE: To detect and characterize gamma-ray bursts.

PROJECT DESCRIPTION

The *Fermi* gamma-ray burst monitor (GBM) is the secondary instrument on the *Fermi* satellite launched in 2008. *Fermi* GBM's primary objective is to detect and characterize gamma-ray bursts (GRBs) and other high-energy emissions from any point on the visible sky (excluding Earth blockage) over a broad energy range (8 keV–40 MeV). *Fermi* GBM was designed to extend the energy range of GRBs detected with the *Fermi* Large Area Telescope (LAT). When GBM sees GRB, the flight software triggers, sending a notice to the ground within several seconds. All events observed by GBM detectors are telemetered to the ground. These event-by-event data are searched for gamma-ray counterparts to gravitational wave events using algorithms developed in collaboration with the Laser Interferometer Gravitational Wave Observatory (LIGO) team.

ACCOMPLISHMENTS

On Aug 17, 2017, at 7:41 am CDT, *Fermi* GBM triggered on a short GRB that lasted about 2 s. This burst looked ordinary in the GBM data but was extraordinary in that it occurred 1.7 s after the first LIGO/Virgo detection of gravitational waves from a merger of two neutron stars. In fact, the automatic notice from *Fermi* GBM alerted the LIGO/Virgo team to take a closer look at their data, because there was a large noise peak in one of their interferometers, so their automated searches did not immediately report the event. The probability of these two events occurring within 1.7 s of one another and in the same part of the sky by chance is 1 part in 20 million. Therefore, they are associated with one another. This association confirms that mergers of two neutron stars produce short GRBs. This particular GRB is unusual because it is the closest known, only 130 million light years away, and that means it is 1,000 times fainter than the next faintest GRB with a known distance. This means that this GRB is likely viewed off-axis (ref. 1). Using the time difference between the arrival of the gravitational waves and the GRB reveals that the speed of gravity is the same as the speed of light within 1 part in 1 quadrillion. The gravitational wave and GRB observations were

followed by observations of this event across the entire electromagnetic spectrum, including gamma-rays, x-rays, ultraviolet, visible, infrared, and radio wavelengths.

SUMMARY

Fermi GBM is the most prolific detector of GRBs, especially short GRBs—those lasting less than 2 s and that are associated with compact object mergers. This event is the dawn of a new era in astrophysics. When LIGO/Virgo resumes operations in late 2018, *Fermi* GBM will be looking for counterparts to new gravitational wave detections.

REFERENCES

1. Goldstein, A.; Veres, P.; Burns, E.; et al.: “An Ordinary Short Gamma-Ray Burst with Extraordinary Implications: *Fermi*-GBM Detection of GRB 170817A,” *Astrophys. J. Lett.*, Vol. 848, No. 2, doi:10.3847/2041-8213/aa8f41, L 14, October 2017.
2. Abbott, B.P.; Abbott, R.; Abbott, T.D.; et al.: “Multi-messenger Observations of a Binary Neutron Star Merger,” *Astrophys. J. Lett.*, Vol. 848, No. 2, L13, October 2017

PRINCIPAL INVESTIGATOR: Dr. Colleen A. Wilson-Hodge

PARTNERSHIPS: University of Alabama in Huntsville, Universities Space Research Association, Max Planck Institute for Extraterrestrial Physics, University College Dublin, Bari, and NASA Goddard Space Flight Center

FUNDING ORGANIZATION: Science Mission Directorate

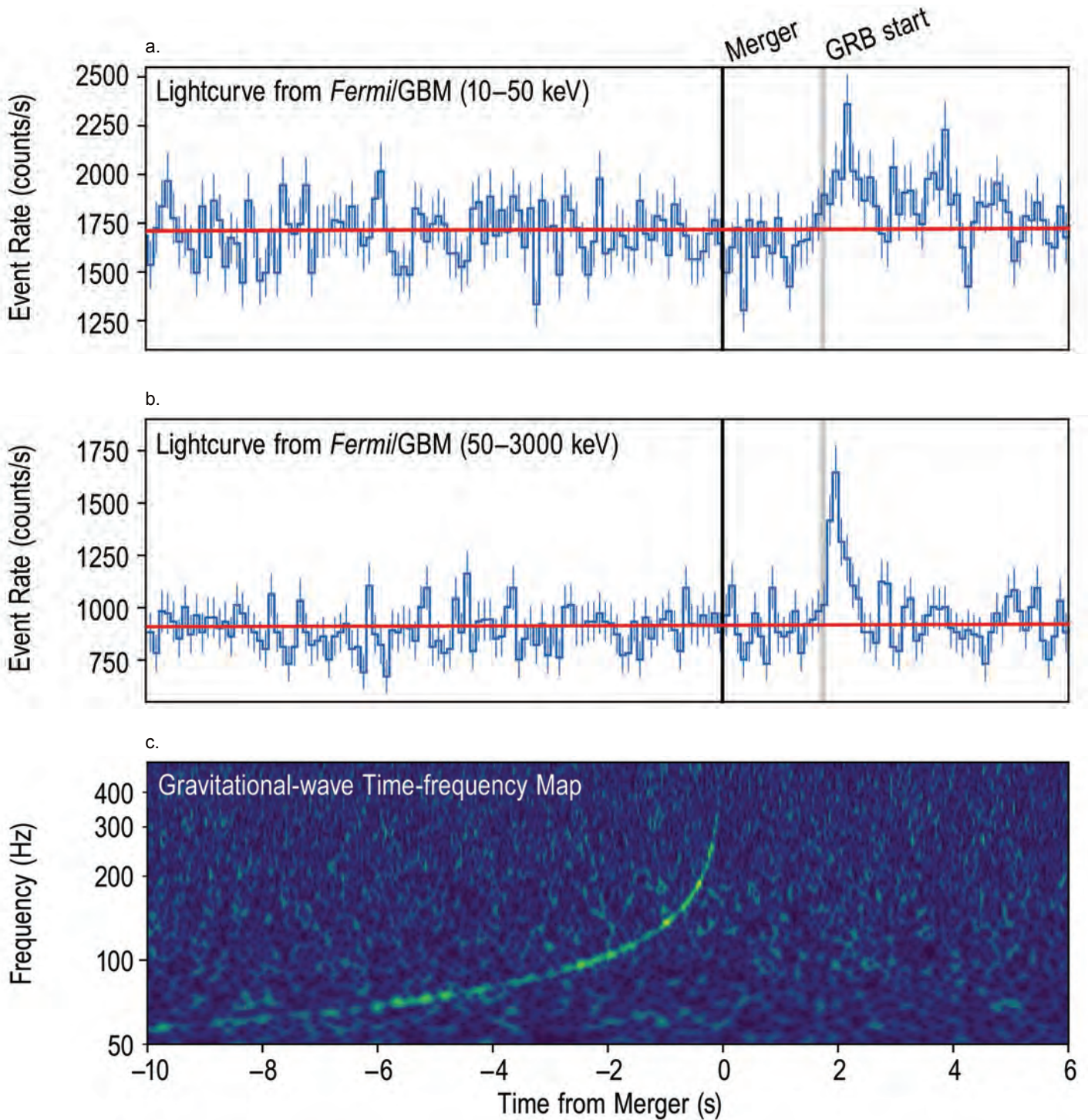

FIGURE 1. Joint multimessenger detection of GW170817/GRB 170817A: (a) *Fermi* GBM light curve (intensity versus time) at lower energies (10–50 KeV), (b) *Fermi* GBM light curve in the triggering energy range (50–300 KeV), and (c) the time-frequency map of GW170817 obtained by coherently combining LIGO-Hanford and LIGO-Livingston data (see ref. 2 for more details).

Hinode

OBJECTIVE: To study magnetic activity on the surface of the Sun and its effects into the solar atmosphere.

PROJECT DESCRIPTION

Due to our increasing reliance on technology, it is critical to study and understand the underlying processes and subsequent potential hazards that we face from transient energetic events occurring on the Sun (such as effects on GPS, science and communication satellite interference, deep-space astronaut transport, power grid blackouts, etc.). The Sun's corona is composed of unexpectedly hot (>1 million °C) tenuous plasma, which is constrained, diverted, and heated by strong magnetic fields and waves. Coronal magnetic fields, anchored in the photosphere, dynamically evolve on large spatial and temporal scales. Reconfiguration of the fields, often via a process referred to as reconnection, releases enormous amounts of energy in the form of plasma heating and particle acceleration. Hinode's scientific objective is to study this magnetic activity on the solar surface and the coronal (atmospheric) consequences. Hinode is an international mission operated by the Japanese Aerospace Exploration Agency (JAXA) in collaboration with space agency partners from the US, UK, and Europe.

ACCOMPLISHMENTS

Accomplishments include:

- (1) The high-resolution (≈ 0.02 arc s/pixel) solar optical telescope (SOT) (<http://sot.lmsal.com/>) was designed to study photospheric magnetic fields using vector magnetic field and white light observations.
- (2) The extreme ultraviolet (EUV) imaging spectrometer (EIS) (<http://msslxr.mssl.ucl.ac.uk:8080/SolarB/Solar-B.jsp>) observes coronal and transition region plasmas to constrain their temperatures and velocities, particularly in association with magnetic reconnection.
- (3) The x-ray telescope (XRT) (<http://xrt.cfa.harvard.edu>) obtains high resolution (≈ 1 arc s/pixel) images of the high-temperature coronal plasma to monitor the transport, storage, and dissipation of magnetic energy in the solar atmosphere.

Solar flare observations and analyses are key to probing the transfer of energy from the Sun into interplanetary space. Magnetic reconnection, a fundamental physical

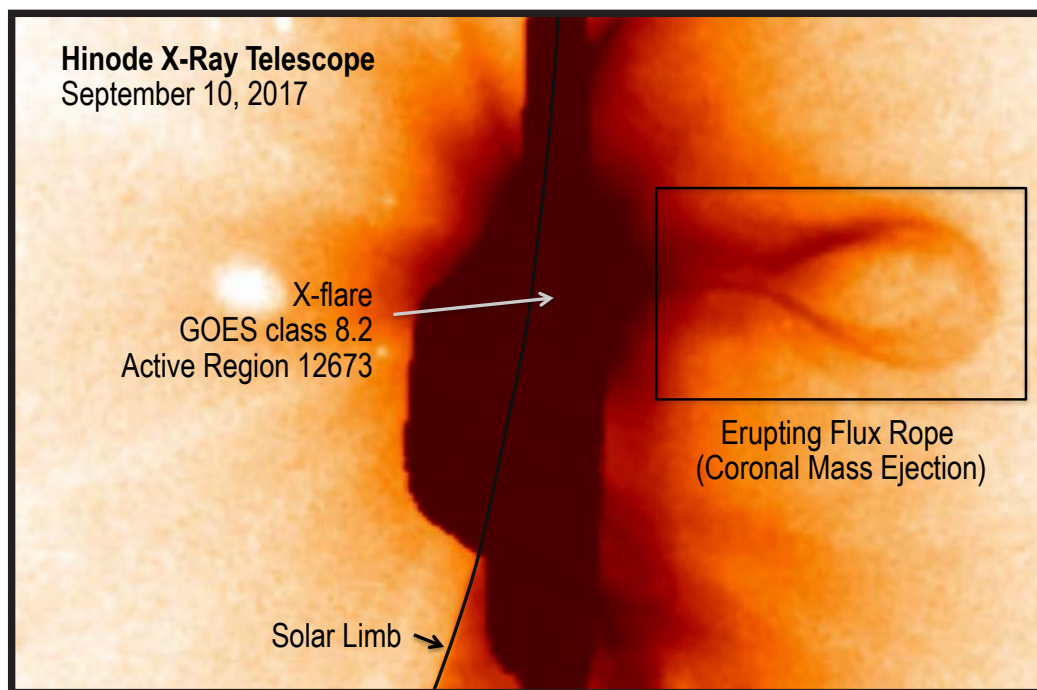

FIGURE 1. Hinode/XRT observation of an x-class flare that occurred on September 10, 2017. This image depicts a flux rope erupting out into the corona from an active region near the solar limb. Image courtesy Japan Aerospace Exploration Agency (JAXA), NASA, and Smithsonian Astrophysical Observatory (SAO).

process in laboratory and astrophysical plasmas, is a highly probable source of massive energy release associated with solar flares. Hinode data are used extensively for such studies. An x-class flare (the largest of the flare classification scheme) was recently well observed by Hinode's EIS and XRT, as well as complementary observatories, on the limb of the Sun as we approach solar minimum and have already begun yielding a wealth of information concerning the response of the atmosphere to presumed reconnection activity. Rare, large-limb events such as this one give us remarkably unobstructed views of key magnetic structures traced by hot plasma and allow us to probe the flows and particle dynamics using precise spectral information.

While strong magnetic fields are the drivers of solar eruptions, the weak fields of the quiet Sun contain a huge amount of combined magnetic flux, comparable to the amount that emerges in active regions in a whole solar cycle! Observing the effects of these fields is a priority for Hinode due to SOT's unprecedented sensitivity to surface magnetic fields. Recent results from reference 1—which describe the topology of these fields and how they relate to simulations—strengthen our understanding of quiet Sun magnetism and provide insight into the source of the Sun's activity cycle.

Another of Hinode's prioritized science goals is to monitor variations in solar activity over a long time period. Since launching in September 2006, Hinode has nearly observed the completion of Solar Cycle 24, which began in January 2008. Hinode/XRT captures full disk images of the Sun twice daily that are used to help determine the source of coronal variability and activity so that we may be able to one day reliably predict the strength of future cycles.

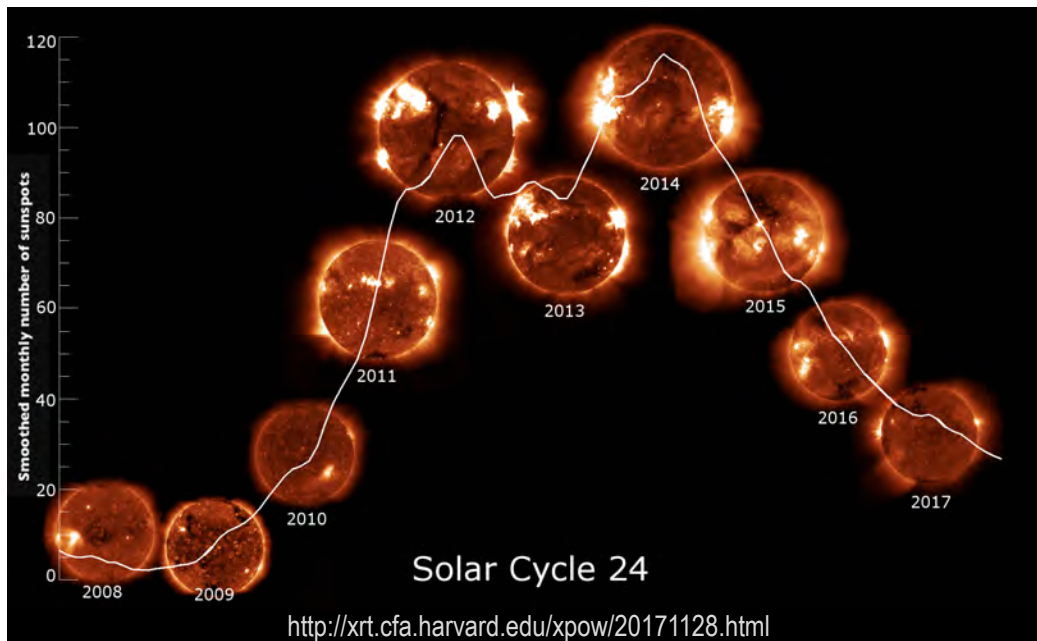

FIGURE 2. Full-disk images of the solar atmosphere as seen in soft x-rays with Hinode/XRT over the course of Solar Cycle 24. Solar activity varies periodically over a nearly 22-yr cycle. Hinode has been operational for half of a complete cycle. Image courtesy JAXA, NASA, and SAO.

SUMMARY

Hinode is a highly capable solar mission operated via extensive international cooperation. The observatory provides the highest quality high-resolution vector magnetic data available from space, unique spectroscopic observations of the million-degree corona, and the only available imaging of the solar atmosphere in the high-temperature soft x-ray wavelength range. Hinode has been operating for over 11 years now and is continuing to change the landscape of solar physics.

PROJECT MANAGER AND PRINCIPAL INVESTIGATOR: Stephen Elrod, Project Manager; Sabrina Savage, US Project Scientist

PARTNERSHIPS: Japanese Aerospace Exploration Agency, European Space Agency ESA, United Kingdom Space Agency

FUNDING ORGANIZATION: Science Mission Directorate

FOR MORE INFORMATION: <https://hinode.msfc.nasa.gov>

Hurricane Imaging Radiometer (HIRAD)

OBJECTIVE: To map surface wind speeds in hurricanes.

PROJECT DESCRIPTION

The hurricane imaging radiometer (HIRAD) is a synthetic, thinned-array, passive microwave radiometer designed to map surface wind speeds in hurricanes. Its four C-band frequencies respond to a combination of radiation from foam on the ocean surface (related to wind speed) and radiation emitted by liquid rain. The antenna technology allows for mapping a wide swath. Traditional instruments suffer either from limitations in heavy rain and high winds, or from inability to view a wide swath.

A key technical innovation with HIRAD is the application of synthetic, thinned-array antenna technology to C-band microwave frequencies. HIRAD has flown and remains flight-capable with its original antenna design. An improved antenna design was developed, but a beamformer optimized for that antenna design is required to take full advantage. A new beamformer design was completed, and a test article built with these

designs paired in 2017. Test results indicate improvement, but further optimization of the beamformer design is warranted before proceeding to a full build. A full antenna/beamformer build with optimized designs would be compatible with the rest of the current instrument (improving measurement quality) and a step toward the desired dual-polarization capability that would allow retrieval of wind direction from a next-generation instrument.

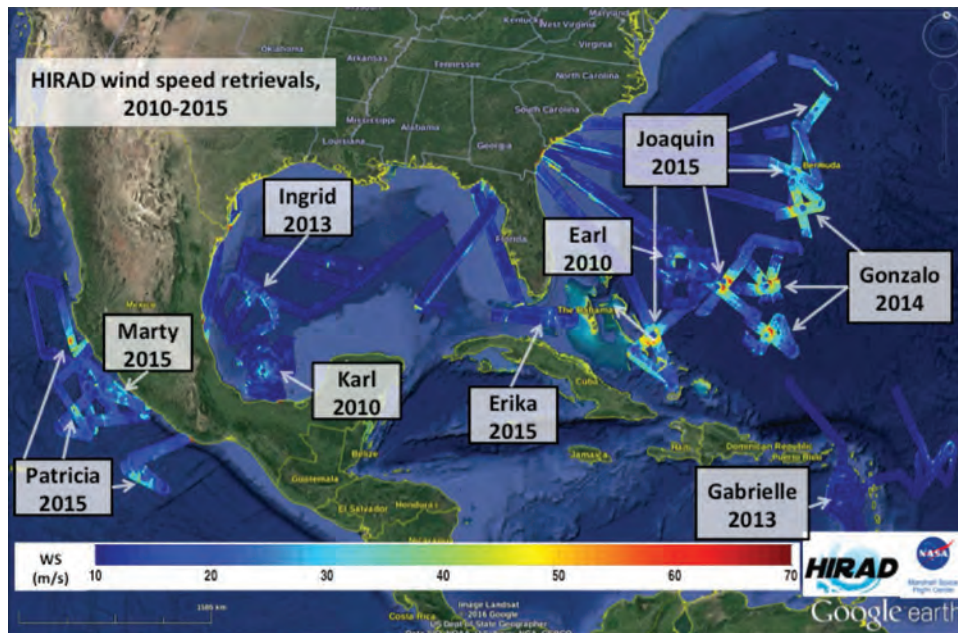

FIGURE 1. HIRAD wind speed retrievals from flights during the 2010–2015 field experiments.

ACCOMPLISHMENTS

Wind speed retrievals produced by HIRAD in 2015 hurricanes Patricia, Joaquin, and Marty were compared with independent wind speed measurements from dropsondes. Root-mean-square errors for HIRAD were estimated as $<5 \text{ m s}^{-1}$, better than expected.

A test article using the new HIRAD antenna and beamformer designs was fabricated and initial tests conducted. Results from those tests indicate improvement over the current instrument's designs, but some deficiencies were noted that should be resolved in a subsequent redesign before moving forward with any new fabrication.

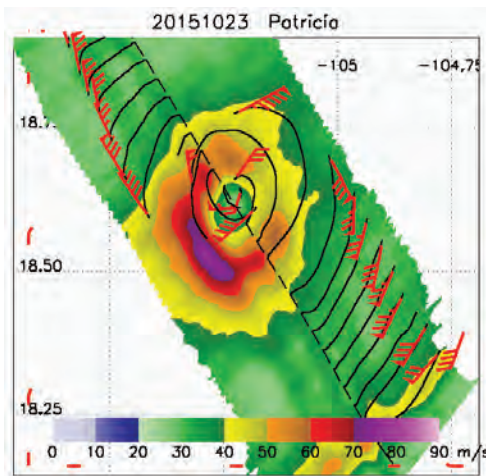

FIGURE 2. HIRAD wind speed retrievals from category-5 Hurricane Patricia (2015), with wind barbs measured by dropsondes overlaid.

SUMMARY

HIRAD data collected in previous hurricanes have been validated and distributed to the scientific community. The instrument remains flight-capable in its current form.

Progress toward new designs have been made, but test results indicate those designs are not yet optimized to the point of moving forward with implementation in a next-generation instrument. The goal for a next-generation instrument is to have improved measurement accuracy and added capability to measure full polarization, in order to retrieve wind direction and other geophysical parameters in addition to wind speed.

PRINCIPAL INVESTIGATOR: Daniel J. Cecil

PARTNERSHIPS: University of Michigan, University of Central Florida

FUNDING ORGANIZATION: Science Mission Directorate

Lightning Imaging Sensor (LIS)

OBJECTIVE: To place a lightning imaging sensor (LIS) on the International Space Station (ISS) to observe global lightning.

PROJECT DESCRIPTION

Over the past 20 years, the NASA Marshall Space Flight Center (MSFC), the University of Alabama in Huntsville (UAH), and their partners have developed and demonstrated the effectiveness and value of space-based lightning observations as a remote sensing tool for Earth science research and applications, and in the process, established a robust global lightning climatology free from significant bias. The lightning imaging sensor (LIS) on the Tropical Rainfall Measuring mission (TRMM) provided global observations of tropical lightning for an impressive 17 years before that mission came to a close in April 2015. Placing an LIS on the International Space Station (ISS) continues the

cross-disciplinary, high-value science begun with TRMM LIS and its optical transient detector predecessor. It does so by creating the opportunity to extend the LIS time series observations, expand coverage to the climatically important mid-latitudes, provide real-time data to operational users, and enable cross-sensor calibration and synergistic observations with other lightning systems. A major science focus of this mission remains to better understand the processes which cause lightning, as well as the connections between lightning and subsequent severe weather events. This understanding is a key to improving weather predictions and saving lives and property in the US and around the world.

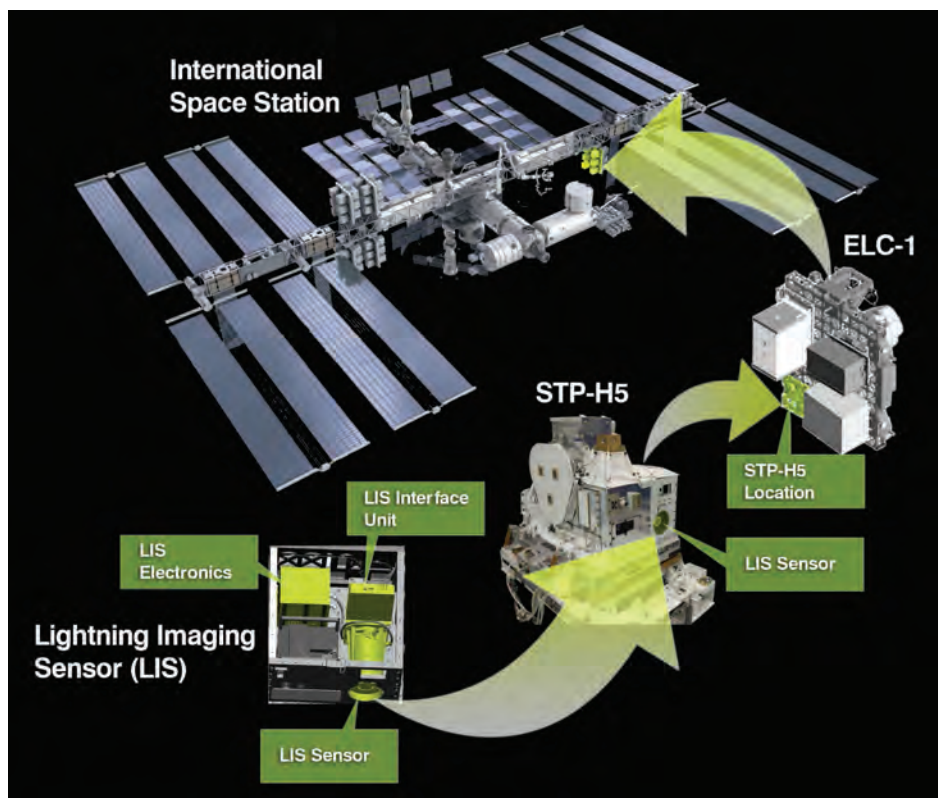

FIGURE 1. The LIS system consists of a legacy electronic unit and sensor unit combined with a new interface unit, designed and built to make the ISS interface appear like the TRMM interface to the flight-spare, legacy components. As illustrated in this drawing, STP-H5 with LIS was robotically installed in a nadir-viewing position at Express Logistics Carrier-1 (ELC-1).

ACCOMPLISHMENTS

The LIS that has now been placed on the ISS is a tried-and-true sensor. This is because it is an exact copy—the backup flight spare in fact—of the LIS that operated flawlessly for an impressive 17 years on the TRMM. To get to the space station, the LIS was integrated as a hosted payload on the Department of Defense Space Test Program-Houston 5 (STP-H5) mission and launched from NASA Kennedy Space Center to the ISS on February 19, 2017, aboard the SpaceX Cargo Resupply Services-10 (CRS-10) flight. Following its arrival at the ISS, STP-H5 with LIS was robotically installed in a nadir viewing location on the outside of the space station as illustrated in figure 1.

From its space station vantage point, LIS continuously measures the amount, rate, and radiant energy of lightning both night and day as it orbits the Earth, detecting 90% or more of the lightning that occurs within its field of view. It is important to note that its ability to detect lightning during the day is especially unique and scientifically important, since more than 60% of the Earth's lightning occurs during the day. To do this, LIS uses a narrowband near infrared channel and special processing to pull the weak daytime lightning signal from the strong solar background reflected from the cloud tops.

The LIS instrument has been continuously acquiring global lightning observations for over 9 months since it was first powered up on February 27, 2017. In October, the LIS science team successfully conducted a Post Launch Assessment Review (PLAR) with NASA Headquarters. Based on its successful on-orbit operations and its compliance with Level 1 science requirement, the LIS team recommended and Headquarters concurred that the LIS on ISS mission be declared as operational. In addition, all agreed that the LIS science data should be publically released once it is reprocessed from mission start by applying important corrections to the timing and geolocation established by major breakthrough analyses concluded in September.

Science and mission operations are managed from the newly established LIS Payload Operations Control Center (LIS POCC), which has enabled both command/control and monitoring of the LIS in real time. The data-handling involves a close partnership between the LIS science team and the Global Hydrology Resource Center (GHRC), one of NASA's Distributive Active Archive Centers (DAAC). The well-established and robust processing, archival, and distribution infrastructure used for TRMM was adapted to the ISS mission to assure that high-quality lightning observations from LIS on ISS can be quickly delivered to science and applications users once routine operations are established.

SUMMARY

Comparisons of the LIS-on-ISS data with observations from three independent reference lightning systems (two from long-range ground-based network, one from the new Geostationary Lightning Mapper that traces its heritage to LIS technology) have established that LIS on ISS is working as well as its predecessor on TRMM. The project will seek a mission extension via the NASA Senior Review process at the conclusion of its nominal 2-year mission in February 2019.

PROJECT MANAGER AND PRINCIPAL INVESTIGATOR:

Steven D. Pavelitz and Richard J. Blakeslee

PARTNERSHIP: UAH

FUNDING ORGANIZATION: Science Mission Directorate

FOR MORE INFORMATION: <https://lightning.nsstc.nasa.gov/index.html>

Lynx X-Ray Observatory Concept Study

OBJECTIVE: To conduct a concept study for consideration as NASA's next flagship astrophysics mission following James Webb Space Telescope and the Wide Field Infrared Survey Telescope.

PROJECT DESCRIPTION

The Lynx X-Ray Observatory is a large mission concept under study to aid the 2020 Astrophysics Decadal Survey Committee in formulating their recommendations for future NASA strategic astrophysics missions. The study goal is to deliver to the Decadal Survey Committee a mission concept that is scientifically compelling and feasible with respect to technical, cost, and risk factors. The study will provide the science objectives, the mission, and observatory performance requirements needed to realize these objectives, a



FIGURE 1. Every decade, a prioritization is made concerning Astrophysics missions by the community. Lynx is a mission concept for a flagship x-ray Observatory being developed for prioritization in the 2020 Decadal, and would launch in the 2030s.

design reference mission, an assessment of the current technology, and a roadmap for technology maturation (and the resources needed), a cost assessment, major risk-mitigation plans, and a top-level schedule for major development phases. The study will culminate in a final report for submission to the Decadal Committee in 2019.

ACCOMPLISHMENTS

A Science and Technology Definition Team (STDT)—selected from the astrophysics community—is leading the Lynx study. NASA Marshall Space Flight Center (MSFC) and the Smithsonian Astrophysical Observatory (SAO) Study Office paired up to perform the study along with 250 scientists worldwide dedicated to Lynx's success. The MSFC Advanced Concepts Office is leading the mission design and is collaborating with the Goddard Space Flight Center (GSFC) Instrument Design Lab for in-depth studies of the science instruments. These mission design and engineering studies are necessary to show a feasible mission path.

The Study Office has established multiple partnerships with industry via Cooperative Agreement Notice contracts to perform assessments and provide inputs in areas of technology maturation, design, analysis and manufacturing.

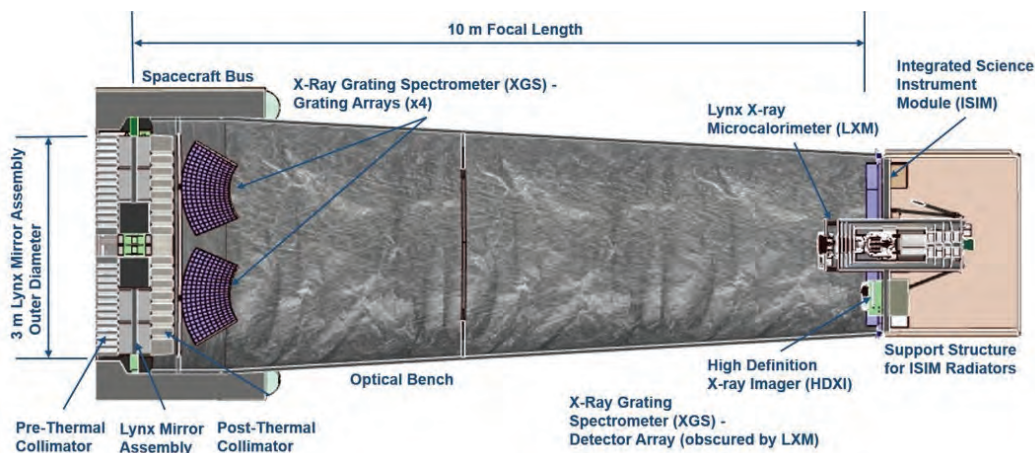

FIGURE 2. Cut-away view of the Lynx Observatory.

The Study Office has also partnered with the University of Alabama in Huntsville (UAH) School of Industrial and Systems Engineering to assist with Systems Modelling Language (SysML) modeling of the Lynx observatory focused on development of concept of operations-type content and identify cost, schedule, and requirements drivers of the system.

ILLUSTRIS COLLABORATION/ILLUSTRIS SIMULATION

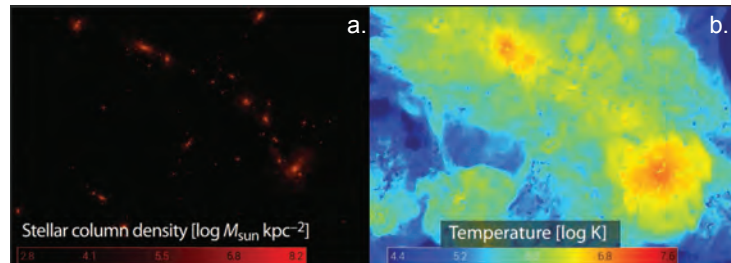

FIGURE 3. Panels of projection of the same region of simulated space (Illustris-TNG simulation: (a) The starlight from the formation of large-scale structures, such as galaxies and (b) a temperature map of the same region that would be visible in x-rays.

The STDT has established the following key science questions to be addressed by Lynx:

- How and when do the first black holes in the universe radiate?
- How do they affect their surroundings?
- How do feedback processes shape galaxies?
- What are the properties of the gas that resides outside of galaxies?

The observatory hardware requirements needed to answer these science questions are an x-ray mirror assembly with large collecting area and high-angular resolution, with two orders of magnitude increase in sensitivity over Chandra; a science instrument suite that is capable of fine imaging, high-resolution dispersive grating spectroscopy at low energies; and imaging spectroscopy across the Lynx waveband.

The assembly, growth, and state of visible matter in cosmic structures are largely driven by violent processes that produce and disperse large amounts of energy and metals into the surrounding medium. In galaxies at least as massive as the Milky Way, the relevant baryonic component is heated and ionized to x-ray temperatures. Only Lynx will be capable of mapping this hot gas around galaxies and in the Cosmic Web, as well as characterizing in detail all significant modes of energy feedback.

The Lynx study team is currently preparing an interim report describing, in detail, credible hardware configurations that will achieve Lynx science goals. In addition

to a thorough description of the scientific goals, this report also presents a discussion on a design reference mission; schedule, risk, and related programmatic considerations; and a technology development road-map. The report recently underwent an external review, and recommendations from that review are being incorporated.

Intensive studies of the Lynx science instruments have been undertaken by the Advanced Concepts Office at MSFC and by the Instrument Design Lab at GSFC. These studies refined the subsystem conceptual designs; evaluated system performance and attributes including mass, power, and data rates; assessed technology risks; and provided preliminary cost estimates. Further design studies are planned for 2018 in preparation for the final report scheduled to be submitted in June 2019.



FIGURE 4. Artists' rendition of the Lynx X-Ray Observatory based on the concept design. If Lynx is selected, it will be the next great x-ray flagship mission.

SUMMARY

The Lynx concept study will conclude Summer 2019, and if selected, will revolutionize our view of the universe by providing unique insight into the high-energy drivers that govern its formation and evolution.

PROJECT MANAGERS AND/OR PRINCIPAL

INVESTIGATORS: Lynx STDT and MSFC Study Office

AUTHORS: Karen E. Gelmis (MSFC ST14), Douglas A. Swartz (USRA/MSFC ST12), Jessica A. Gaskin (MSFC ST12)

PARTNERSHIPS: SAO

FUNDING ORGANIZATION: Science Mission Directorate

FOR MORE INFORMATION: <https://wwwastro.msfc.nasa.gov/xrs/>

Objective Estimation of Tropical Cyclone Intensity

OBJECTIVE: To utilize ‘deep learning’ to objectively and automatically estimate tropical cyclone intensity.

PROJECT DESCRIPTION

Severe impacts of tropical cyclones are well documented. The main factor that contributes to the resulting death toll or damage amount is associated with the wind speed. Damage models also approximate the threat using a power of wind speed. Thus, being able to accurately estimate a tropical cyclone’s intensity (defined as the maximum sustained surface wind speed) is essential for disaster preparedness and response.

Direct measurements of a tropical cyclone’s intensity are sparse. The diagnosis of a tropical cyclone’s initial intensity and recent intensity change, using just satellite data, is still a challenge. Improving the initial intensity estimates from satellite imagery could potentially lead to major improvement in short-term intensity forecasting, thereby improving our Nation’s disaster preparedness and response.

Most researchers and forecasters currently rely on the satellite image-based technique developed in the 1970s for estimating tropical cyclone intensity. These techniques utilize infrared temperatures from satellite and employ human visual inspection of image features, such as the curvature of the cloud field. There are known limitations with Dvorak-based techniques, namely, the subjectivity of humans in identifying the features. Two well-trained analysts using this technique can derive different intensity estimates.

There is clearly a vital need to develop an automated, objective, accurate tropical cyclone intensity estimation tool from satellite data. We use deep learning to address this need and develop an automated and objective tropical cyclone intensity estimation service. Deep learning, currently state-of-the-art in machine learning and pattern recognition, is a multilayer neural network consisting of several layers of simple computational units. It learns discriminative features without relying on a human expert to identify which features are important.

ACCOMPLISHMENTS

First, we built a training dataset for satellite image-based intensity estimation. We used cyclone imageries from US Naval Research Laboratory from 1998 to 2014 coupled with wind speed and track data (HURDAT) from National Hurricane Center. We were able to collect 98 different cyclones and label about 49,000 images. We constructed a custom convolutional neural network (CNN) and trained on these images and created a model. Figure 1 shows a visualization of feature maps for first layer of CNN. Using the model, we were able to achieve higher accuracy than existing techniques in estimating wind speed using just satellite images. Our method is completely objective and automated. Currently, we are developing a system that—in real time—monitors tropical storm watches, triggers collection of relevant satellite images, and estimates storm intensity.

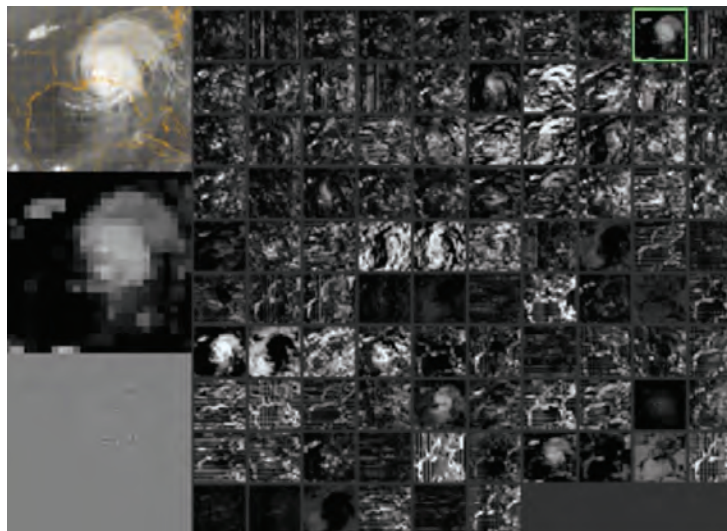

FIGURE 1. First convolution output for a GOES IR with hurricane. Top left: Inset is input image from NRL. Middle left: Example feature map for highlighted box (green).

This is the first project that utilizes deep learning for objectively estimating tropical cyclone intensity. At the beginning of 2017, a prototype system was developed. The prototype demonstrated higher level of accuracy when compared to the literature affirming the potential and paving the way for full system development. A case

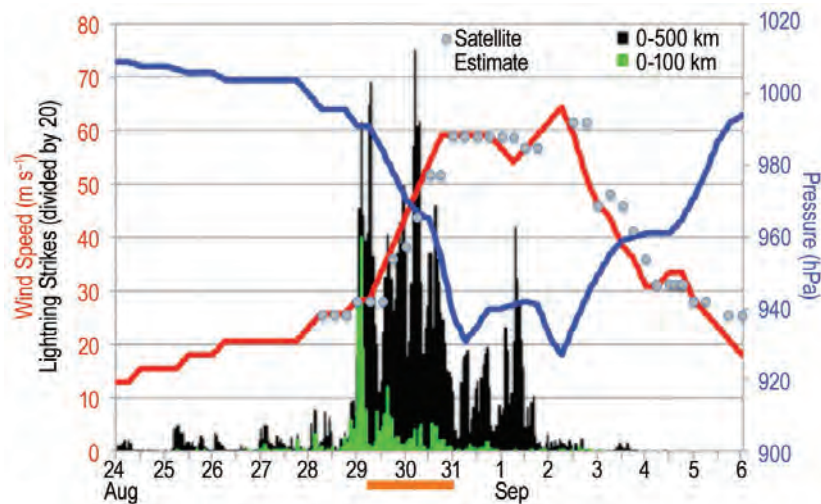

FIGURE 2. Time series of satellite-derived intensity estimates (circles) for Hurricane Earl (2010), added to best track intensities and lightning flash rate time series (adapted from ref. 1.)

study for Hurricane Earl is shown in figure 2. Towards an end-to-end system to forecast tropical cyclone intensity, the project has utilized NASA’s cloud-based workflow system (Cumulus) to listen to storm watchers and forecast intensity information more frequently than currently being done. Furthermore, a design of a hurricane portal and web services are underway for end users and applications to interface.

SUMMARY

We have created and trained a deep CNN to objectively estimate tropical cyclone intensity. Results show that estimation accuracy is significantly improved. This generalized trained model can be used to estimate intensity for new satellite images for any region in subseconds. This project intends to enable eventual infusion of the intensity estimation service at forecast centers.

REFERENCE

1. Stevenson, S.N.; Corbosiero, K.L.; and Molinari, J.: “The Convective Evolution and Rapid Intensification of Hurricane Earl (2010),” *Mon. Weather Rev.*, Vol. 142, No. 11, pp. 4364–4380, November 2014.

PROJECT MANAGER AND/OR PRINCIPAL INVESTIGATOR: Manil Maskey
FUNDING ORGANIZATION: Science Mission Directorate

Testing and Calibration of the Parker Solar Probe Mission SWEAP Solar Probe Cup

OBJECTIVE: To perform space environment testing of the Solar Probe Cup.

PROJECT DESCRIPTION

During the lifetime of NASA's Parker Solar Probe (PSP) mission that includes 24 orbits of the Sun, the spacecraft periaapsis moves ever closer, eventually getting as close as 9.85 solar radii, or about 4 million mi from the surface. The close approach to the Sun is necessary to explore the mysteries of solar corona heating; explore the formation, energization, and structure of the solar wind; and explore mechanisms that accelerate and transport energetic particles. To investigate these science goals, the spacecraft includes an instrument suite called the solar wind electrons, alphas, and protons (SWEAP). SWEAP consists of two types of plasma instruments: Solar probe analyzer (SPAN) and

solar probe cup (SPC). NASA Marshall Space Flight Center (MSFC) was responsible for verifying the SPC performance in certain space environments.

The SPC instrument design is based on the successful Faraday cup design that has flown on many spacecraft; e.g., Voyager, Wind, and the Deep Space Climate Observatory (DSCOVR). Although the SPC for the PSP mission may have similar operational characteristics of the past Faraday cup sensors, the Sun-viewing orientation will put the SPC in an environment like no other plasma instrument has faced—the SPC must withstand over 500 times the solar intensity as compared to a sensor in Earth orbit. As such, the materials and construction of the SPC is like none before.

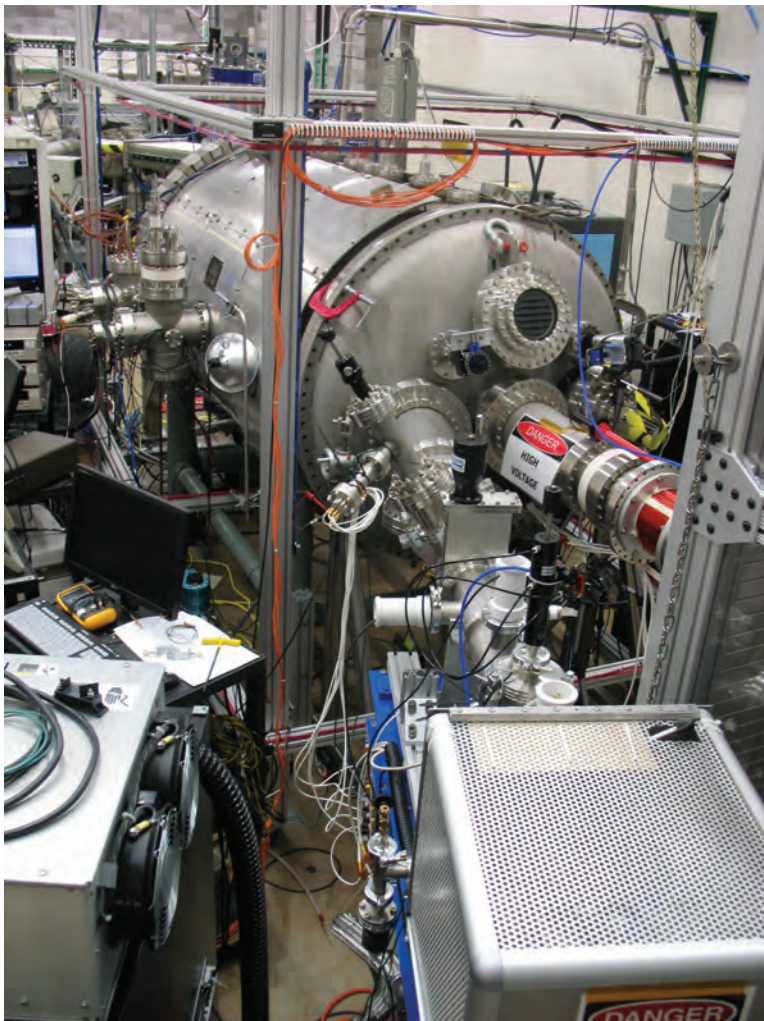
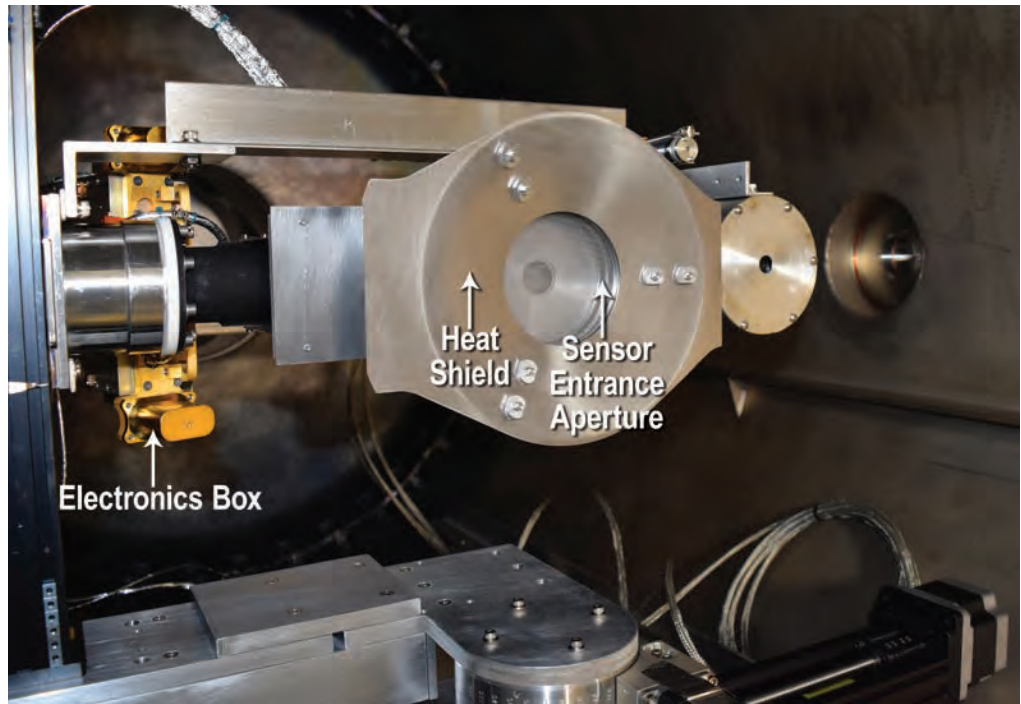

FIGURE 1. MSFC's Solar Wind Facility located in Building 4605.

FIGURE 2. FM SPC in SWF during calibration tests.



ACCOMPLISHMENTS

Marshall Space Flight Center (MSFC) partnered with the Smithsonian Astrophysical Observatory (SAO) to develop and test the SPC and provided information concerning candidate high-temperature materials for design of the SPC. MSFC also developed high-fidelity particle sources, while SAO developed a high-fidelity solar simulator for testing the evolution of the SPC design.

Figure 1 shows MSFC's Solar Wind Facility (SWF) that was developed for testing the SPC. The SWF is a high-vacuum ($< 1e^{-6}$ Torr) chamber serviced by oil-free pumps. It has broadbeam ion and electron sources and a third source to facilitate a narrow or pencil beam of ions. Helmholtz coils are used with the electron beam to keep the beam in a relatively fixed position within the chamber. The broadbeam ion source can provide energies between 140 eV and 8,100 eV, while the broadbeam electron source provides energies between 90 eV and 2,100 eV. Both sources provide a range in flux over several orders of magnitude. The pencil beam setup can provide ions up to 10 keV. A rotational stage in the chamber allows the angular response of the SPC to be determined.

In January 2017, the SPC Qualification Module (QM) sensor was tested in the SWF particle beams. The performance of the QM sensor demonstrated its expected behavior. Subsequent to SWF testing, the QM sensor

was subjected to vacuum thermal cycling at MSFC in March 2017. Anomalous measurements observed during electrical functional testing during thermal cycling necessitated a design change to the SPC. The redesigned FM SPC sensor returned to MSFC in August 2017 and successfully completed vacuum thermal cycling. In September 2017, the FM SPC sensor, together with the FM electronics box, completed calibration testing of SWF and verified all of its performance requirements necessary to meet the PSP mission science goals. Figure 2 shows the FM SPC sensor and electronics box in SWF.

SUMMARY

MSFC completed the required space environment testing of SPC in a timely manner such that the SPC could meet its delivery to the spacecraft. Launch of the PSP is scheduled for July 31, 2018.

MSFC PROJECT MANAGER: Michael Effinger

MSFC PRINCIPAL INVESTIGATOR: Dennis Gallagher

MSFC INSTRUMENT SCIENTIST: Kenneth Wright

SWEAP PRINCIPAL INVESTIGATOR: Justin Kasper/
University of Michigan

PARTNERSHIP: Smithsonian Astrophysical Observatory

FUNDING ORGANIZATION: Science Mission Directorate

FOR MORE INFORMATION: <http://parkersolarprobe.jhuapl.edu>

Snap-IMS: A Snapshot Hyperspectral Imager for Earth Remote Sensing

OBJECTIVE: To develop, deploy, and test a novel snapshot hyperspectral imaging capability for Earth remote-sensing science and application on a range of small airborne and space platforms.

PROJECT DESCRIPTION

The innovative aspect of the Snapshot Image Mapping Spectrometer (SNAP-IMS) is the ability to acquire instantaneous snapshot images in a large number of spectral bands with high-spectral and spatial resolution. The digital imaging system of the IMS allows the collection of full spectral information in the image scene instantaneously at real-time imaging rates. The ability to obtain an instantaneous scene, in contrast to current, commonly implemented, push-broom scanning, will be a major advancement in Earth remote sensing, as it enables spectroscopic observations of a wide range of fast-transient atmospheric, ocean, and surface phenomena. A prototype snapshot imaging system was built, scaled to fly as a 3U (CubeSat) experiment (fig. 1). It was designed to meet the specified mass, volume, and power requirements of a 3U. The instrument was flight-tested on board the Marshall Space Flight Center (MSFC) Octocopter Unmanned Aerial System (UAS) for which the payload requirements are very similar to that of 3U.

The following are the Innovative IMS principles:

- IMS utilizes field redistribution with a mirror array.
- Mirror array introduces 350 unique tilts to the reflected image.
- Passing through a lenslet/prism array, the line images are spatially separated on the detector into 24 groups, allowing enough void space for spectral dispersion without spatial/spectral overlap.
- Detector is a commercially available SONY Alpha-7 DSLR 24.3 MP camera.
- No scanning; thus, eliminating scanning motion artifacts.
- The entire hyperspectral datacube of $350 \times 400 \times 55$ (x, y, λ) is acquired within a single exposure of the camera's frame.

- Made with in-house aluminum optomechanics and off-the-shelf lenses and mirrors at minimal cost.

Innovative image path folding with mirrors reduces weight and size. The beam path of the IMS was folded with four mirrors to fit within the allowable dimensions of the unmanned aerial vehicle (UAV) while preserving system magnification and telecentricity. The image is acquired with the downward pointing front optic. The final system size came in at $288 \times 150 \times 160$ mm with a weight of 3.6 kg, easily integrating with the UAV.

Understanding advantage of using SNAP-IMS in remote sensing applications is easily derived from knowledge of the datacube dimensions and the measurement architecture. For example, for a datacube of dimensions $(N_x, N_y, N_\lambda) = (500, 500, 100)$, a whisk-broom (point scanning) system sees only 100 voxels of the datacube at any given time. If the remainder of the object is emitting light during this period, then all light emitted outside these 100 voxels is lost. The overall light collection efficiency from geometric considerations alone is thus the inverse of the number of elements in the scan—in this case $1/(N_x N_y)$, 4×10^{-6} . This value is very low, particularly if imaging the Earth's surface. For a pushbroom (line scanning) system, one sees a 500×100 slice of the datacube at a given time, so the maximum full-cube efficiency value is $1/N_y = 0.002$. While many uses can tolerate such a low efficiency, dynamic scenes prevent the longer integration times needed to overcome this poor light collection. Since the λ scan dimension in our example is one fifth that of the spatial dimensions, filtered cameras have the potential to provide a five-fold improvement in light collection ability.

This year's objectives are as follows:

- **Decrease size:** Starting with Rice's current system, the IMS components will be scaled down to fit within an approximate 3U footprint.
- **Optimize foreoptics:** Lenses and mirrors will be selected and integrated into the instrument in order to provide optimal ground observations from a low-altitude UAS test platform.
- **Integrate with airframe:** The complete SNAP-IMS instrument will be integrated into a chassis suitable for containing and protecting the various components while also providing a mounting system for attachment to the UAS platform during operations.
- **Demonstrate functionality:** SNAP-IMS will be flown on the UAS platform and operated to collect data in a series of functionality demonstration flights. These flights will be carried out in series with several evaluation periods during which image and ancillary system data will be analyzed and utilized iteratively to improve system performance and data quality.

Work is continuing with a funded NASA Instrument Incubator Program NNH16ZDA001N-IIP proposal entitled "Tunable Light-guide Image Processing Snapshot Spectrometer (TuLIPSS) for Earth Science Research and Observation."

ACCOMPLISHMENTS

SNAP-IMS was built and integrated with an octocopter UAV and flown to acquire initial test results at MSFC. SNAP-IMS weighed only 3.6 kg and was capable of acquiring 55 spectral channels simultaneously in the

visible light spectrum. SNAP-IMS demonstrated high light-throughput which allowed the collection of Hyperspectral datacubes at 1/500–1/100 s, eliminating motion artifacts associated with drone movement. Hyperspectral spectra derived from the images were consistent with the type of surface imaged, i.e., grass, water and a parking lot.

SUMMARY

SNAP-IMS System was successfully integrated with an Octocopter UAV and imaged terrain 100 to 150 ft at MSFC. It demonstrated the capability of imaging visible spectrum as a snapshot hyperspectral imager with no scanning time. Spectrum obtained from various surfaces were consistent with published spectra for similar materials.

REFERENCE

1. Hagen, N.; Kester, R.T.; Gao, L.; and Tkaczyk, T.S.: "Snapshot advantage: a review of the light collection improvement for parallel high-dimensional measurement systems," *Opt. Eng.*, Vol. 51, No. 11, 13 pp., doi:10.1117/1.OE.51.11.111702, June 2012.

PROJECT MANAGERS: Paul Tatum; MSFC Scientist Jeff Luvall

PRINCIPAL INVESTIGATORS: Tomasz S. Tkaczyk and David Alexander

PARTNERSHIPS: Department of BioEngineering, Rice University

FUNDING ORGANIZATION: Cooperative Agreement Notice

Advanced UVOIR Mirror Technology Development for Very Large Space Telescopes

OBJECTIVE: To mature technology to enable 4-m or larger ultraviolet, optical, infrared (UVOIR) space telescope primary mirrors.

PROJECT DESCRIPTION

Advanced Mirror Technology Development (AMTD) project is in phase 2 of a multiyear effort to mature towards Technology Readiness Level 6 (TRL-6) by 2018. This requires critical technologies required to enable 4-m or larger ultraviolet, optical, and infrared (UVOIR) space telescope primary-mirror assemblies for general astrophysics and ultra-high contrast observations of exoplanets.

ACCOMPLISHMENTS

AMTD has completed its defined tasks and milestones. The 1.5-m diameter ULE[®] mirror (that is, a 1/3-scale model of a 4-m mirror) was low-temperature slumped to an F/2.4 sphere and its thermal and mechanical performance characterized. Lessons learned from its fabrication have been documented. Using thermal performance data from the 1.2-m Extreme-Lightweight Zerodur[®] mirror, an analysis tool was developed to calculate coefficient of thermal expansion (CTE) homogeneity distribution from thermal performance data. An AMTD-developed contrast leakage analysis tool is being used by the Habitable Exoplanet Imaging Missions (HabEx) optical telescope engineering

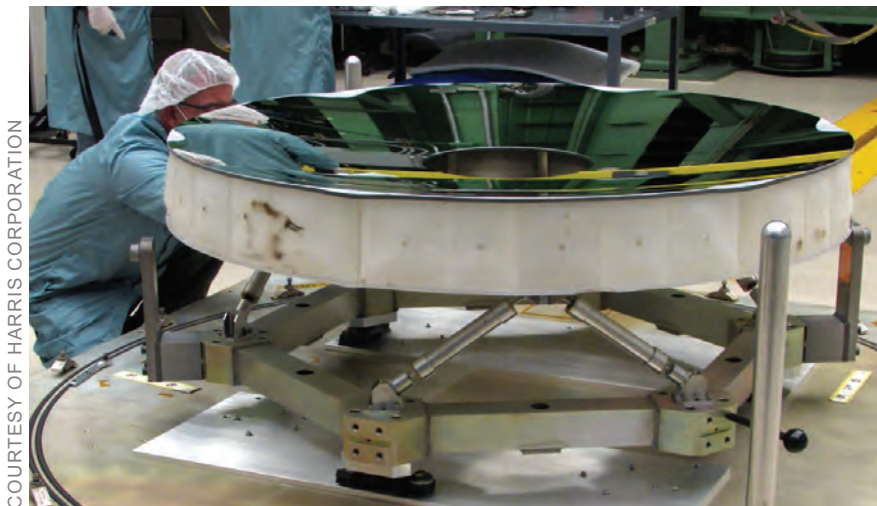

COURTESY OF HARRIS CORPORATION

FIGURE 1. 1.5-m diameter deep-core AMTD ULE[®] mirror manufactured by Harris Corporation.



FIGURE 2. Thermal image of AMTD mirror in test setup.

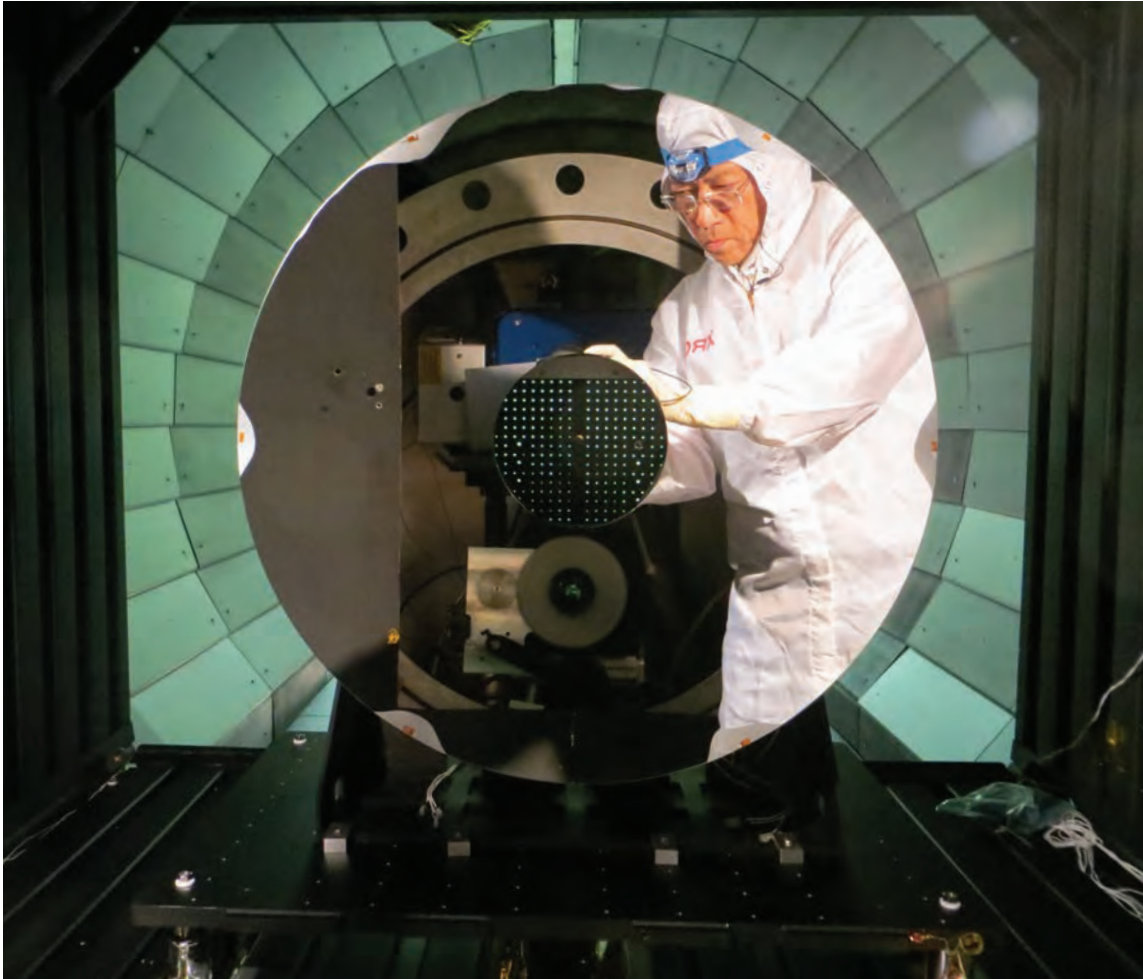

FIGURE 3. AMTD mirror in test setup.

team to define optomechanical stability tolerances. The Arnold Mirror Modeler has been released and is being used to design the HabEx optical telescope. AMTD provided two undergraduate internships for mentoring the next generation of scientists and engineers. Finally, AMTD results were given in four presentations at Mirror Tech Days 2017 and four papers at 2017 SPIE Astronomy Conference.

SUMMARY

AMTD developed analysis tools for quickly designing mirror systems; and demonstrated methods and documented lessons learned for manufacturing deep-core 4-m mirrors with reduced schedule and cost. Additionally, AMTD developed and demonstrated abilities to characterize required mirror performance.

PROJECT MANAGERS: H. Philip Stahl and Michael Effinger

FUNDING ORGANIZATION: Science Mission Directorate

The Imaging X-Ray Polarimetry Explorer (IXPE)

OBJECTIVE: To measure the x-ray polarization of a wide variety of x-ray sources.

PROJECT DESCRIPTION

The Imaging X-Ray Polarimetry Explorer (IXPE) will be the next in the line of NASA's Small Explorer missions. After IXPE was selected in January 2017, NASA plans to launch it into an equatorial orbit in April 2021. IXPE will study the x-ray polarization properties of dozens of sources per year, representing the following source categories: Active galactic nuclei, microqua-

XPE is the first-ever imaging x-ray polarimeter. It relies on unique position- and polarization-sensitive detectors provided by our international partners in Italy. Coupled with these detectors, x-ray optics built at Marshall Space Flight Center (MSFC) complete the critical elements of the scientific payload. Figure 2 is a schematic of the detector illustrating the principle of operation.

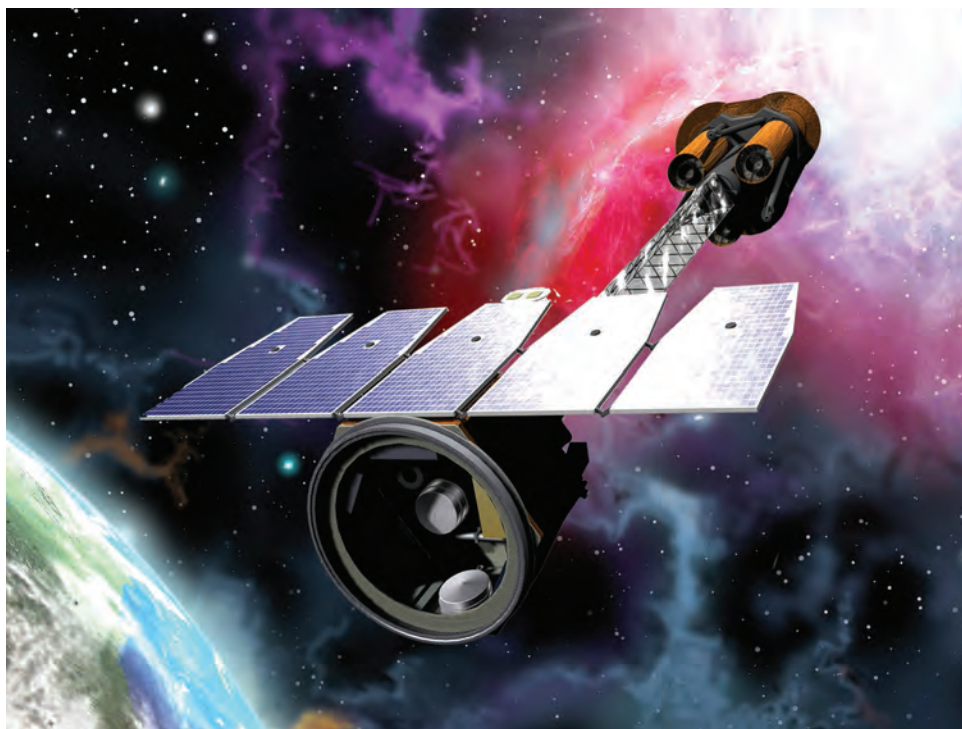

The detector is a position-sensitive proportional counter that is capable of imaging the entire track of the charge produced by the incident x-ray photo-ionizing the detector gas. The initial direction of the photoelectron is along the electric vector of the incident photon.

sars, radio pulsars and pulsar wind nebulae (PWNe), supernova remnants (SNR), magnetars, and accreting x-ray pulsars. Besides obtaining spectropolarimetry at moderate (proportional-counter) energy resolution, IXPE will conduct phase-resolved polarimetry of bright (isolated and accreting) pulsars, as well as imaging x-ray polarimetry of the brightest extended sources (e.g., PWNe and SNR). Figure 1 shows IXPE after deployment with major systems identified.

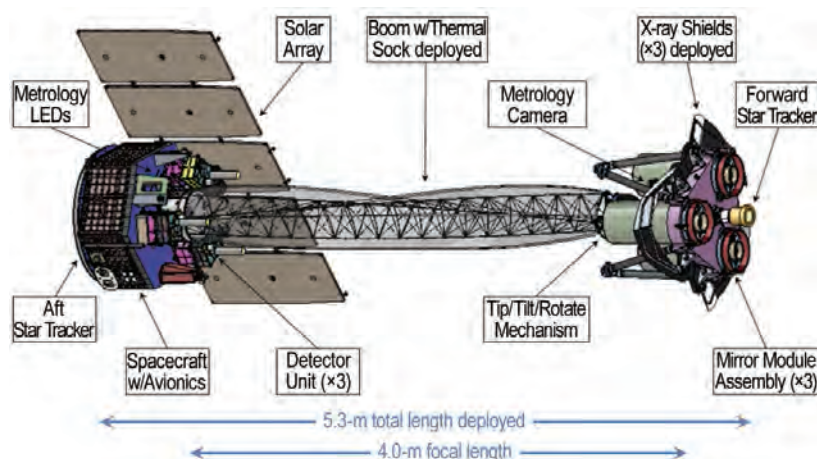

FIGURE 1. IXPE deployed.

ACCOMPLISHMENTS

Accomplishments include:

- Getting selected for Phase B development.
- Completing a rephrase and re-plan due to unavailability of funds for FY2018.
- Holding and passing two major requirements reviews: Mission system requirements review (SRR) and instrument SRR.
- Maturing the following major interface control documents: Instrument to spacecraft, thermal shields to mirror module assembly (MMA), and MMA to mirror module support structure.
- Completing an early coupled-loads analysis, allowing for planning of a vibration isolation system.

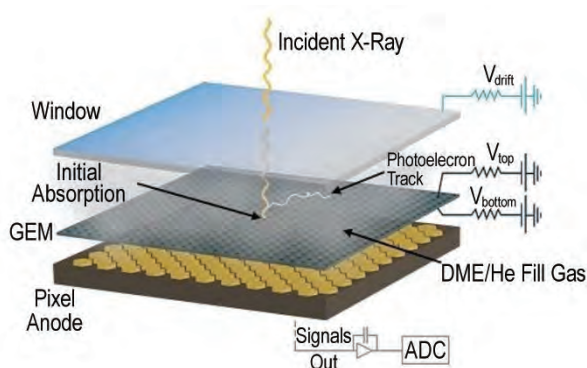

FIGURE 2. Schematic of the IXPE detector.

- Completing an early thermal analysis allowing for development of IXPE-aeroheating requirements for the launch vehicle interface requirements document.
- Completing two spacecraft design iterations.
- Making significant progress toward design/development of the MMA and the detector units.
- Accomplishing the first delivery of flight-like hardware.

SUMMARY

IXPE is progressing as planned. Next year, there will be several milestones, including the instrument preliminary design review (PDR) and critical design review as well as the payload, spacecraft and mission PDRs. This latter PDR will be followed by the key decision point C review, which is the confirmation to allow IXPE to enter into phase C/D.

PROJECT MANAGER AND/OR PRINCIPAL INVESTIGATOR: Martin C. Weisskopf (PI)

PARTNERSHIPS: The Italian Space Agency Agenzia Spaziale Italiana, Istituto di Astrofisica e Planetologia Spaziali/Istituto Nazionale di Astrofisica; and Istituto Nazionale Fisica Nucleare, Ball Aerospace, MIT, and Stanford University

FUNDING ORGANIZATION: Science Mission Directorate

FOR MORE INFORMATION: <https://ixpe.msfc.nasa.gov/>

Next-Generation Lightning Instrument Package (LIP) via Merged Sensor and Data Technologies

OBJECTIVE: To create a state-of-the-art sensor for airborne thunderstorm and lightning investigations by applying an innovative technology approach to merge sensor and data system technologies.

PROJECT DESCRIPTION

The Marshall Space Flight Center Lightning Instrument Package (LIP) represents a unique airborne research capability for conducting detailed electrical investigations of thunderstorms and lightning. Over the more than 16 years since the current LIP has been flying, there have been significant advances in digital signal processing, microcomputer technology, and digital communications. This advancement has enabled improved capabilities that may be packaged into smaller space, blurring the previous lines between sensor and data system (similar to the progression of cell phone technology; it's no longer just a phone but

also a computer, camera, GPS, watch, etc.). The current LIP airborne architecture utilizes 6–8 electric field sensors per aircraft installation to measure the electric field. These sensors, called electric field mills (EFMs), detect the quasistatic atmospheric electric fields by the ‘chopping’ action of a mechanical modulator. LIP also employs distributed embedded Linux systems for data acquisition, command/control, and internet communication. The focus and goal of this project is to create a state-of-the-art, next-generation LIP for airborne storm and lightning research that takes advantage of recent advances in technology to merge sensor and data system technologies together, simplifying and improving the overall design and operation of the LIP system.

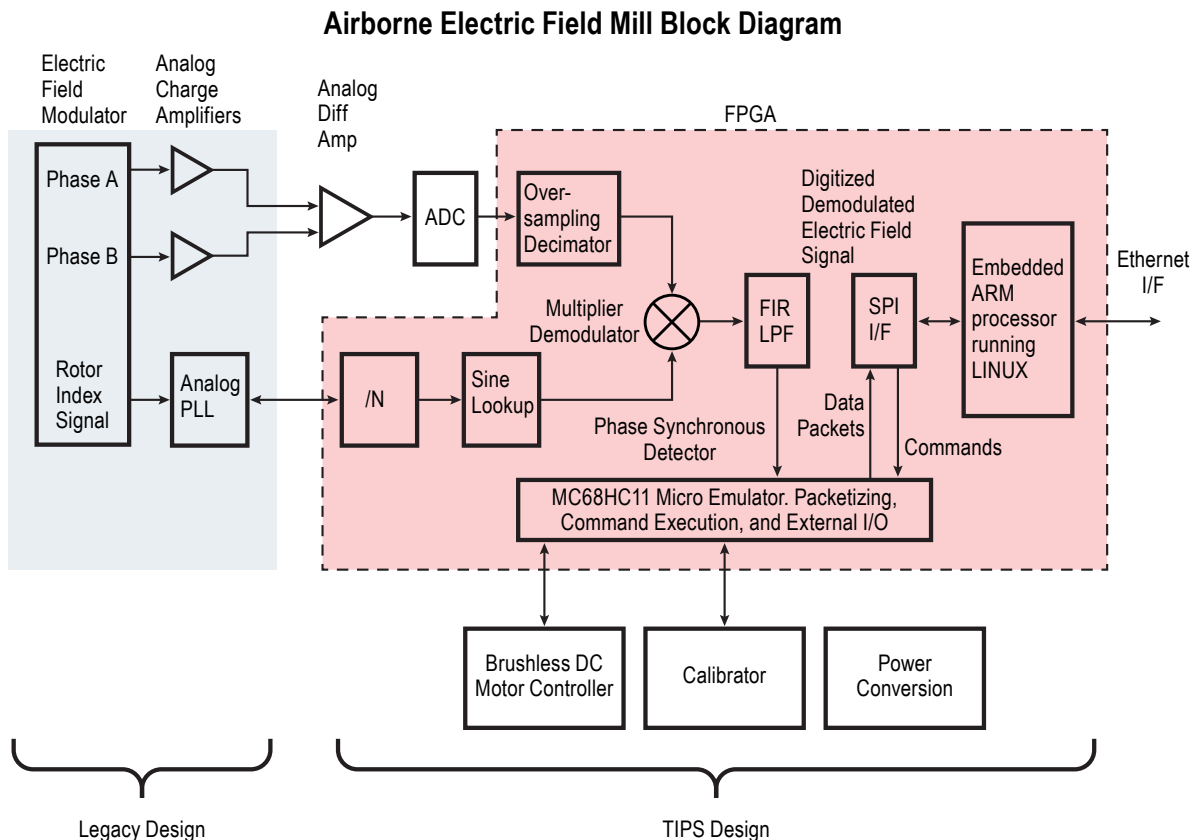

FIGURE 1. Block diagram of the data flow and processing electronic for the redesigned LIP electric field mill.

ACCOMPLISHMENTS

A block diagram of the implemented EFM electronic signal processing is shown in figure 1. In the new EFM signal processing circuitry, a digital signal processing phase synchronous detector replaces the earlier analog version. Except for amplification, digitization, and phase reference synchronization, all circuit functions are implemented within a field programmable gate array (FPGA). In addition to reduced circuitry size and improved reliability and stability, the design reduces noise and interference by employing a digitally synthesized sinusoidal phase reference signal that avoids the odd harmonic intermodulation components that arise when a traditional square wave signal is used as the phase reference. An over-sampling decimator is utilized to increase the signal-to-noise ratio of the analog-to-digital converter (ADC) to ensure that wide dynamic range of the field measurement is achieved. The analog signal processing from the charge amplifiers through the ADC (left side of fig. 1) has been implemented on a single-circuit card assembly. The remainder of the electric field signal processing, including the functionality associated with the legacy MC68HC11 Microprocessor, is all implemented within the FPGA.

Even the Linux computer has now been fully implemented within the FPGA, completely eliminating the need to have any external data system at all, since all the data system and internet functions are now built into each EFM. This higher level of integration allowed us to achieve our goal of reducing the number of circuit cards required from 5 to 3. The project can also reuse most of the structural components in creating the new LIP system since mechanically, these remain solid, and the mechanical design remains state-of-the art, providing significant cost savings.

The FPGA code receives the 24-bit oversampled electric field data from the ADC and averages, decimates, demodulates, and filters it to produce data packets with 50 S/s, 10 Hz bandwidth, 32-bit output electric field samples. The performance of the prototype EFM has been evaluated on a parallel plate fixture that provides positive and negative electric fields from 0 V/m to $\pm 34,700$ V/m. Using this fixture, the full-scale range was adjusted to be ± 802 kV/m, with a minimum sensitivity of 2 V/m, producing a dynamic range of 112 dB, or 18.3 effective bits. This large dynamic range is necessary for aircraft measurements where the aircraft can become electrically charged to produce a local electric field of several hundred thousand V/m yet the ambient fields to be measured can be as low as a few 100 s V/m.

SUMMARY

A prototype was designed, fabricated, and tested for the next-generation LIP electric field sensor for airborne thunderstorm and lightning investigations. This prototype utilizes innovative technology to merge sensor and data system technologies. For instance, the electric-field signal processing that was formerly performed with analog circuitry is now performed with digital signal processing. Another advancement is incorporating the functionality associated with an 8-bit microprocessor and a Linux-based, single-board computer, within an FPGA. The next step will be to apply these upgrades to the existing EFM sensors to create the next-generation airborne LIP system.

PRINCIPAL INVESTIGATOR: Richard J. Blakeslee

PARTNERSHIP: University of Alabama Huntsville

FUNDING ORGANIZATION: Technology Investment Program

Predictive Thermal Control Technology for Stable Telescopes

OBJECTIVE: To mature active thermal control technology to enable ultrastable ultraviolet, optical, infrared (UVOIR) space telescopes.

PROJECT DESCRIPTION

Predictive thermal control (PTC) matures technology to enable thermally stable telescopes required to make ultrahigh contrast observations of exoplanets. PTC accomplishes this by doing the following: (1) Validating models that predict thermal optical performance of real mirrors and structure based on their structural designs and constituent material properties, i.e., coefficient of thermal expansion (CTE) distribution, thermal conductivity, thermal mass, etc.; (2) deriving thermal-system-stability specifications from wavefront stability requirements; and (3) demonstrating ability of a PTC thermal system to thermally stabilize a mirror system.

ACCOMPLISHMENTS

PTC has modified Marshall Space Flight Center's (MSFC's) X-Ray and Cryogenic Facility (XRCF) to introduce thermal gradients into mirror systems. This capability has been tested on the 1.5-m Advanced Mirror Technology Development (AMTD) ULE[®] mirror. The next step is to add active thermal control systems to this mirror. Working with the Habitable Exoplanet (HabEx) Imager mission, PTC defined thermal performance requirements for candidate mirror systems. Using x-ray computed tomography, PTC created a high-fidelity 'as-built' model of the 1.5-m AMTD ULE mirror. PTC has developed a process for correlating measured thermal performance with CTE homogeneity. Finally, PTC results were presented in two papers at the 2017 SPIE Astronomy Conference.

SUMMARY

The PTC team plans to demonstrate a new paradigm to produce an ultrastable optical telescope via physics-based active thermal control. If successful, it will enable the ongoing search for habitable exoplanets by allowing scientists to accurately image the coronas of distant stars.

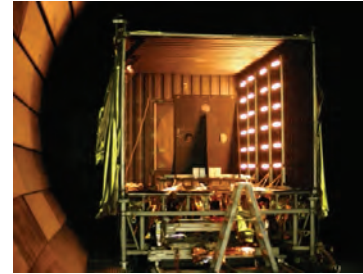

FIGURE 1: PTC/XRCF thermal characterization test setup with solar simulation lamps for lateral thermal gradient.

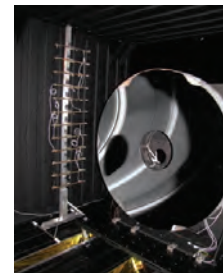

FIGURE 2: AMTD 1.5m ULE[®] mirror in test setup.

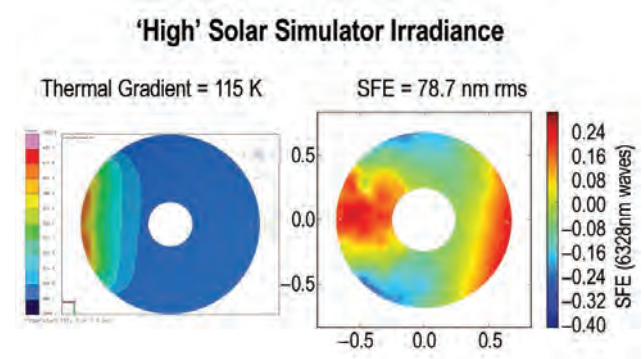

FIGURE 3: Measured lateral thermal gradient.

FIGURE 4: Measured surface deformation.

PROJECT MANAGERS: H. Philip Stahl and Michael Effinger

FUNDING ORGANIZATION: Science Mission Directorate





MODELING AND INFORMATION TECHNOLOGY

The technologies profiled in this section focus on advances in foundational capabilities for flight computing and ground computing; physics-based and data-driven modeling, simulation, and software development; and information and data processing frameworks, systems, and standards. Taken as a whole, this technology area has impact on most of the NASA technology portfolio. The foundational modeling, simulation, information technology, and processing technologies in this area

enable the development of application-specific modeling, simulation, and information technologies that are found throughout the other technology roadmaps. These technologies also form the base of the capabilities NASA needs to meet the ever-increasing modeling, simulation, information technology, and processing demands of the next missions in exploration, science, and aeronautics. Hence, these technologies are an important component of solutions to NASA's greatest challenges.



Immersive Decision-Making Environment (IDME) for Mission-Driven Technology Alignment (MDTA)

OBJECTIVE: To demonstrate the value of providing easy access to digital information across Marshall Space Flight Center domains and to connect a digital thread between engineering disciplines using a common data backbone.

PROJECT DESCRIPTION

The goal of the Immersive Decision Making Environment (IDME) for Mission Driven Technology Alignment (MDTA) Cooperative Agreement (CA) was to determine the value that could be gained by providing easy access to information across NASA domains. Specifically, the goal was to characterize a ‘digital data backbone’ that provided access to data that enables mission capability, technology alignment, and decision support using real-world examples, such as transportation architectures and missions, an upper stage methane engine, and additive manufacturing.

The CA demonstrated how Marshall Space Flight Center could work in a common information pipeline where architectural analysis, engine design, simulation, and advanced manufacturing have access to each other’s information so that advanced engine and enabling technologies can be assessed at the architectural and lower levels.

The CA provided a capability and technology demonstration (CTD) of Siemens software tools in a space

industry application of an enterprise-level mission-driven technology alignment capability. A CTD is a method to demonstrate how technology and process enhancements might provide enhanced capability in a previously unexplored manner. It is also a learning tool to understand limits of technology and process that block possible capabilities and to understand the boundaries therein. The CTD followed a Day in the Life (DITL) model approach. DITL is a software demonstration model used to show technologies, capabilities, information flow, and business process concepts. It is a rough user-centric example of an incomplete version of a future system for the purposes of showcasing applications, user data interactions, and business methods. (Basically, it’s a story to be told to the audience.) It is broken up into use cases that illustrate a specific domain, process and/or capability enhancement(s).

ACCOMPLISHMENTS

Four DITL use cases were completed demonstrating various elements of connecting and reusing data between engineering disciplines across a digital backbone.

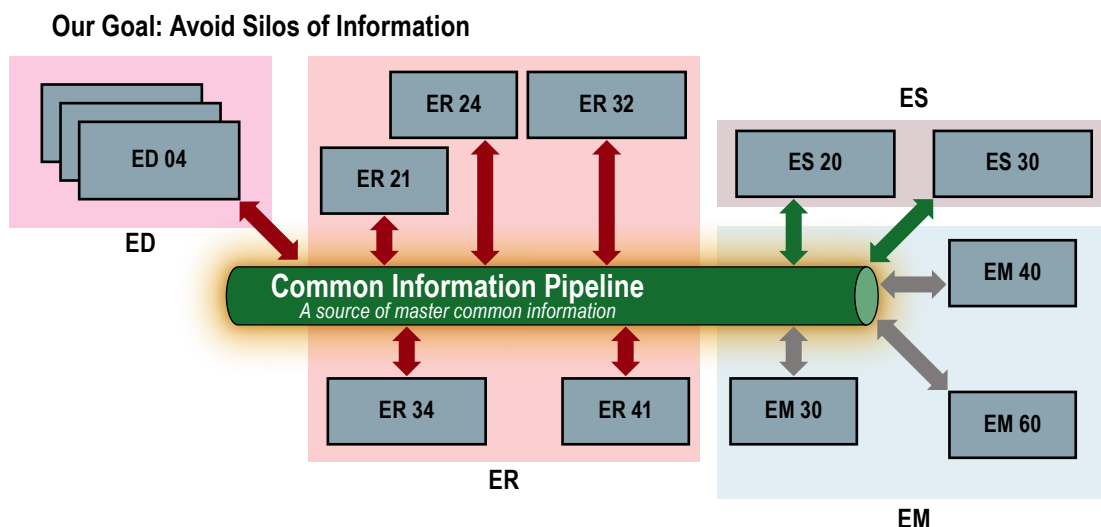

FIGURE 1. MSFC digital data backbone.

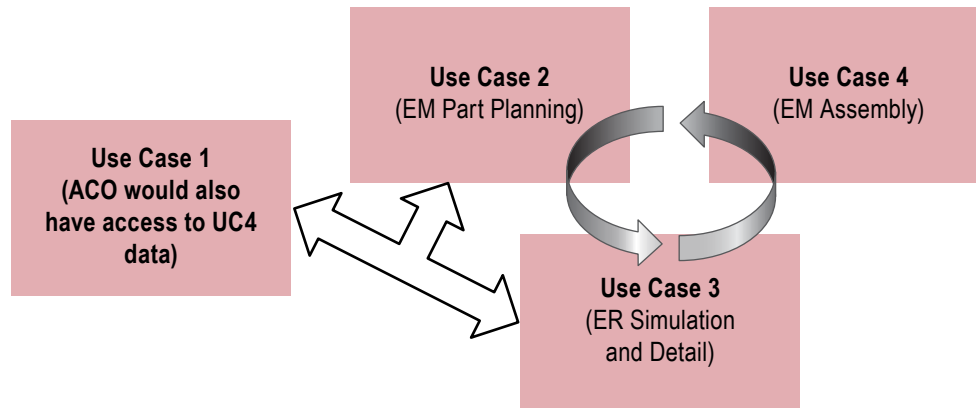

FIGURE 2. Use case interactions.

Use case 1—multiphysics collaboration: This use case focused on building from the existing multiphysics simulation RL10 model and commercial-off-the-shelf liquid propulsion libraries to conduct a trade study comparing different rocket engine cycles. Multiphysics simulation system models were created to support methane as a fuel. Pressure-fed, expander cycle, gas-generator cycle, and oxygen-rich staged-combustion cycle engine configurations were considered.

Use case 2—manufacturing part planning: Manufacturing received candidate rocket engine parts for additive manufacturing in computer-aided design- (CAD-) based structure. These parts had appropriate properties added and then were submitted to a workflow for initial analysis (UC3 Simulation). Manufacturing built the required part-based process plans to generate these parts via additive manufacturing. A set of design changes was quickly incorporated into the planning, enabled by the linked data.

Use case 3—detail design and simulation: This use case demonstrated that Siemens Teamcenter could effectively manage Creo CAD data and that models could be associatively shared and modified during a design/analysis cycle.

Use case 4—assembly planning: In this use case, manufacturing process planning used the CAD-based structure to generate a manufacturing bill of materials (MBOM); using this MBOM structure, the user created the assembly processes needed to assemble the engine. This output was then sent to Solumina for execution by the appropriate organization. Manufacturing process planning was able to quickly react to design changes due to automatic links to the MBOM.

SUMMARY

In summary, the benefits to MSFC are the following:

- Demonstrating the validity of efficiently linking, manipulating, and visualizing mission/enterprise relevant technical data at multiple levels.
- Evaluating a multiphysics simulation package.
- Illustrating a collaborative change management environment between propulsion design and manufacturing.
- Illustrating a collaborative computer-aided engineering data management environment.
- Becoming a smarter buyer for engineering tools.

The benefit to Siemens are the following:

- Providing a case study/demonstration of Siemens software tools in a space industry application of an enterprise-level mission-driven technology alignment capability
- Identifying and demonstrating desired industry capabilities in the AMESim rocket reuse library with real data.
- Identifying and patching security concerns for out-of-the-box Siemens code.
- Improving processes for managing ANSYS data.

PROJECT MANAGER: Joel Rooks/Siemens

MSFC TECHNICAL OFFICERS: Pat Hunt, Boise Pearson, Dave Whitten

MSFC TECHNICAL LEADS: Boise Pearson, Steven Phillips, Dwight Goodman, Keith Swearingen

SIEMENS TECHNICAL LEADS: Jim Sweeney, Gerry Deren, Pat O'Heron, Bernie Kennedy, Mike Walker

FUNDING ORGANIZATION: Cooperative Agreement Notice

Cloud-Based App Design (AVAIL)

OBJECTIVE: To establish the Agency Video, Audio & Imagery Library (AVAIL) as the official place to go on the internet to find published NASA imagery for download and reuse.

PROJECT DESCRIPTION

NASA has provided popular imagery on the internet as long as there has been an internet, but the photos and videos have been spread across various collections, on different websites, with different interfaces and feature sets. The goal of the Agency Video, Audio and Imagery Library (AVAIL) is to provide a single site where public users can search through and download high-quality copies of the best of NASA's imagery assets from across the Agency's history, Centers, programs, and projects.

AVAIL was designed from the outset for the Cloud, using cloud-based tools and services where possible, and adhering to cloud-native, modern design. The result is an application that is moderate in resource use but can scale up for large events—or for growth over time—to handle whatever the internet throws at it.

ACCOMPLISHMENTS

The site was formally released in March 2017. It provides simple search and browsing of over 150,000 photographs and videos from NASA's collection, with more being added every day. Images from every Center and the primary Agency programs are regularly updated

with fresh content. The ability to download high-resolution versions of content is a key feature of the site.

SUMMARY

AVAIL was NASA's first public-facing imagery site developed for the Cloud from its inception, providing a solid foundation for development far into the future. The simple interface makes finding specific images more intuitive while also highlighting the rich collections of beautiful imagery that are part of NASA's legacy. It works well on both desktop computers and mobile phones or tablets. The architecture is ready for growth in both the collection and number of users and is flexible enough to add new technologies as they are added to the fabric of the Cloud.

The original release has been well received. A collection of new features is moving toward development of what will eventually be AVAIL 2.0.

PROJECT MANAGERS AND/OR PRINCIPAL INVESTIGATORS: Rodney Grubbs, Maura White, and Bryan Walls

PARTNERSHIP: NASA Web Services Office

FUNDING ORGANIZATION: Advanced Exploration Systems

FOR MORE INFORMATION: <https://images.nasa.gov>

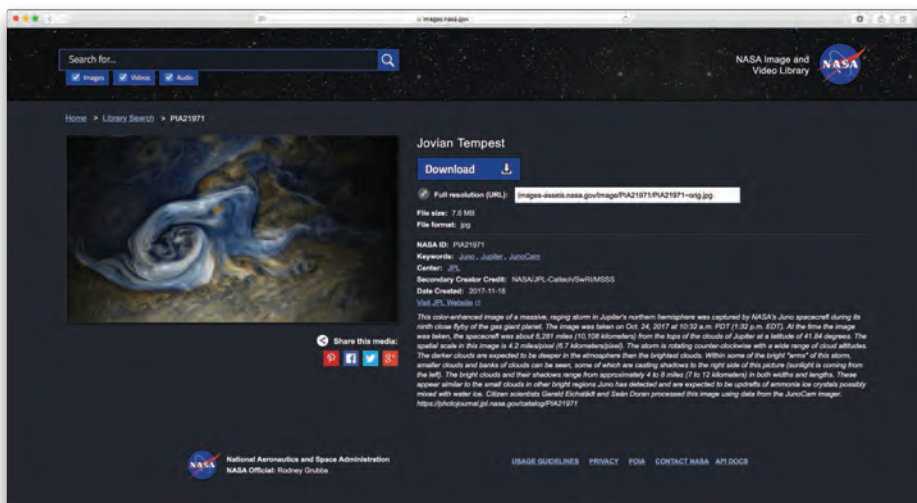

FIGURE 1. Screenshot of a specific image available for download through AVAIL.

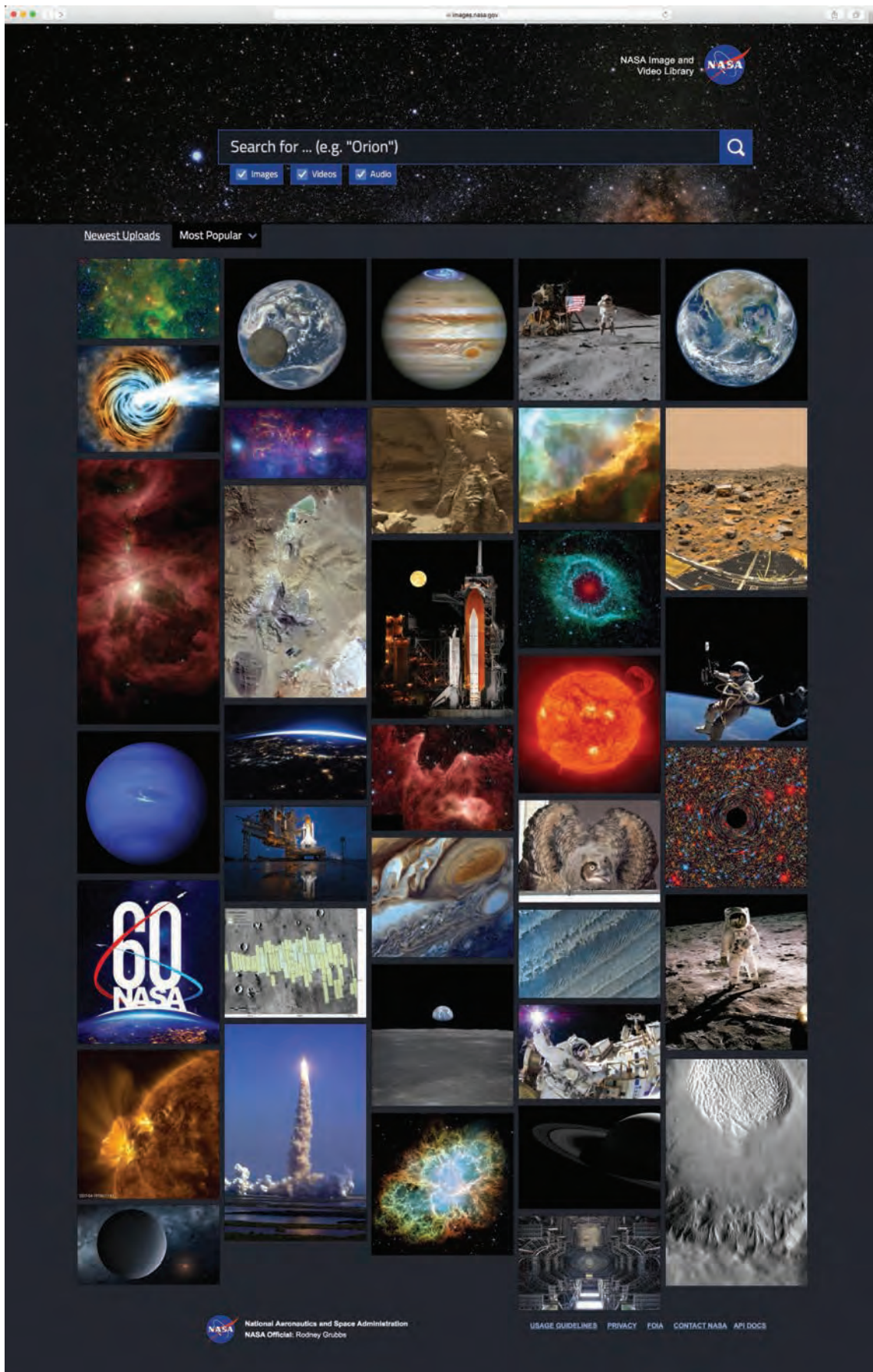

FIGURE 2. Screenshot of the home page of AVAIL at <http://images.nasa.gov>.

Short-Term Prediction Research and Transition (SPoRT)

OBJECTIVE: To transition unique satellite observations and research capabilities to the operational weather community to improve short-term, regional forecasts.

PROJECT DESCRIPTION

Short-term Prediction Research and Transition (SPoRT) is an end-to-end research-to-operations/operations-to-research (R2O/O2R) activity focused on accelerating the use of satellites, nowcasting tools, and advanced modeling and data assimilation techniques to improve short-term weather forecasts. SPoRT partners with universities and other government agencies to obtain near real-time data, develop new products, and obtain operational perspective to increase the likelihood of adoption by the operational weather community.

SPoRT incorporates the end user throughout an iterative R2O/O2R feedback process (fig. 1) by identifying a forecast challenge, incorporating a potential solution into the user's decision support system (DSS), providing training on use of the product, and assessing the product's impact on their decision-making process.

Product iterations continue until a solution is used in regular forecast operations. Collaborative relationships between SPoRT and its partners enable honest feedback on the value of products and training, resulting in lasting operational impact of new data products. Often, this feedback includes suggested product changes that lead to significant improvements, increased use of the product, and additional opportunities for research and development. Assessment reports published for the broader community communicate successful product transitions. These activities are collaborative and complementary to work done by testbeds at the National Oceanic and Atmospheric Administration (NOAA) National Weather Service (NWS) National Centers and Cooperative Institutes.

ACCOMPLISHMENTS

SPoRT has contributed to the transition of Geostationary Lightning Mapper (GLM) and Advanced Baseline Imager (ABI) observations from the GOES-16 operational weather satellite to operational forecasters at NOAA NWS. Using NASA investments in ground-based lightning networks in parts of the U.S., SPoRT aided the NWS in developing GLM visualizations and application cases for severe weather and lightning safety. Using NASA Earth observations with similar spatial and spectral characteristics to ABI to provide early access to data products, SPoRT completed transition of a set of value-added, multispectral (or Red-Green-Blue [RGB]) imagery to improve forecaster efficiency in interpreting the new satellite observations (e.g., fig. 2). SPoRT collaborated with NWS software developers on visualization modules in the NWS Advanced Weather Interactive Processing System (AWIPS) DSS, enabling all forecasters in the U.S. to use these data products and visualizations in their operational data stream. Additionally, SPoRT led development of foundational and applications training, including quick guides and 'how-to' videos.

SPoRT completed transition of precipitation rain rate measurements from the NASA Global Precipitation Measurement mission to several NWS weather forecast

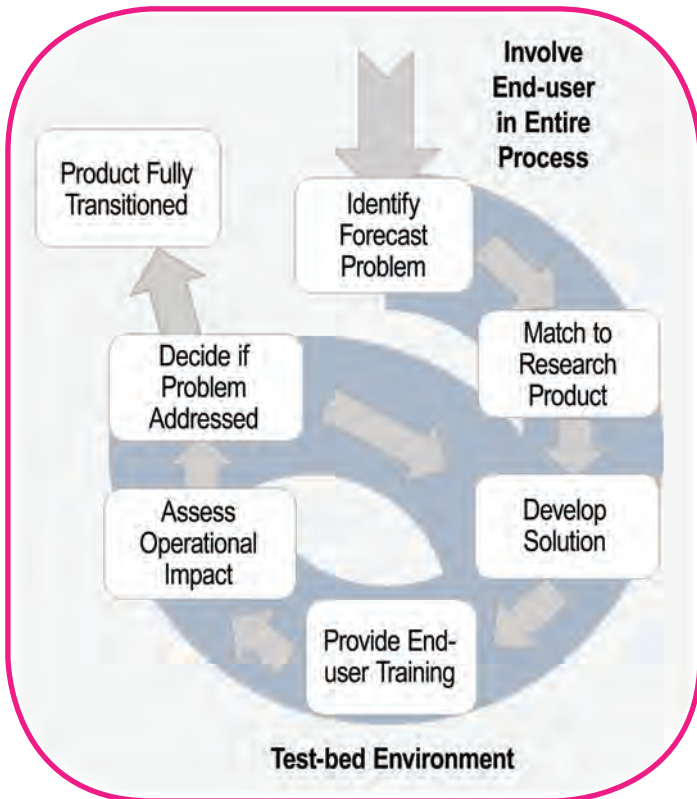

FIGURE 1. Graphical representation of the SPoRT unique R2O/O2R paradigm.

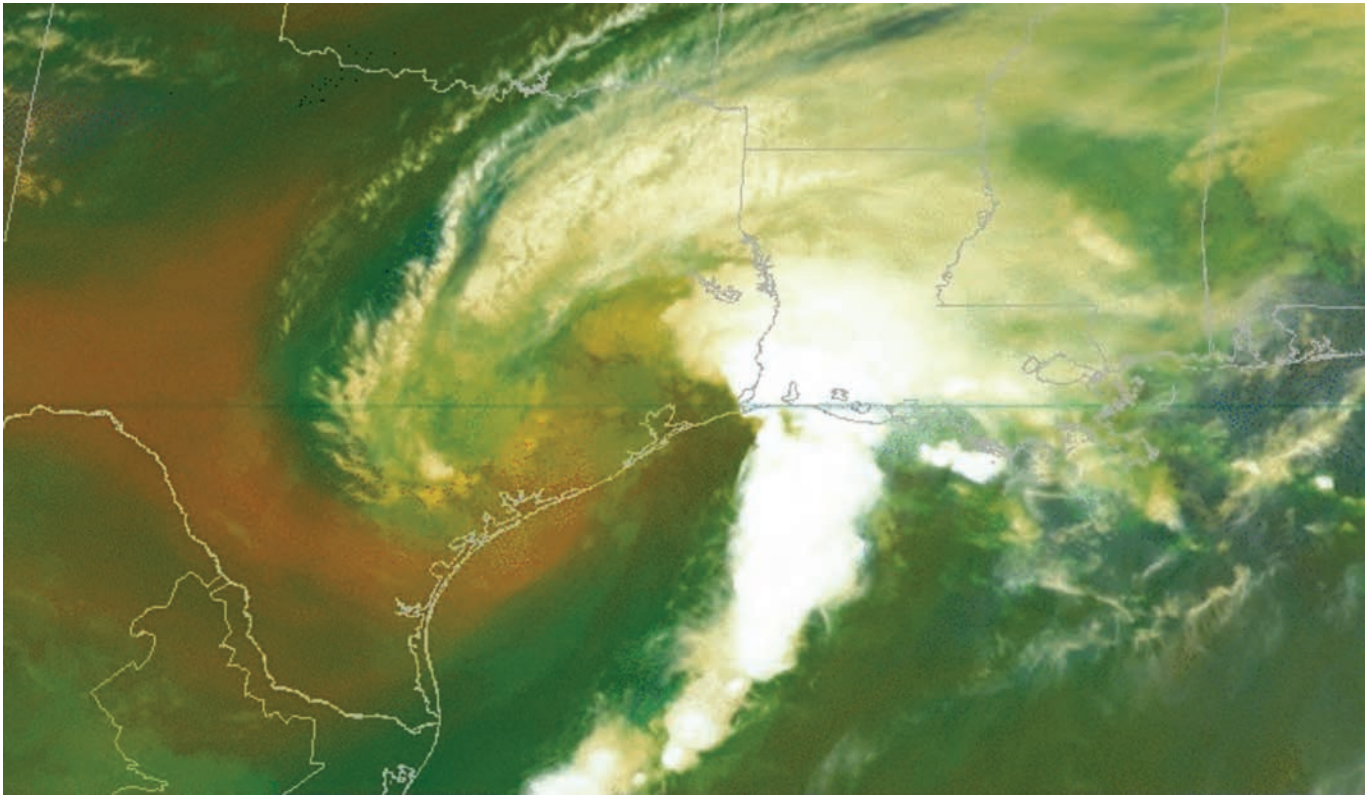

FIGURE 2. GOES-16 Air Mass RGB image showing intrusion of dry air (orange/red coloration) into the southern edge of Hurricane Harvey (2017) on August 28, 2017.

offices (WFOs) and river forecast centers (RFCs) in the Southwest United States and Alaska. Products from the NASA-developed Integrated Multi-satellite Retrievals for GPM (IMERG) near-global gridded precipitation products have integrated an operational hydrologic model used for forecast flooding at NWS RFCs. Precipitation rain rate products have been used by forecasters to identify areas of heavy precipitation in data-void regions that are outside of the range of traditional ground-based observing systems, such as Doppler radar or rain gauges.

SPoRT has completed integration of retrieved soil moisture observations from the NASA Soil Moisture Active/Passive (SMAP) mission into an offline version of the NASA Land Information System (LIS). Inclusion of SMAP data provides more direct measurement of important near-surface soil moisture conditions that have previously been determined primarily by precipitation in land surface models. This data is expected to better represent the land surface for situational awareness and initialize regional numerical weather prediction and hydrology models. Several NWS forecast offices have used the SPoRT-LIS products to issue areal flood guidance, categorize droughts, and detect locations with higher risks for wildfires.

SUMMARY

SPoRT is a highly successful project that conducts world-class research and transition activities with a model that is both sustainable and able to evolve with new opportunities. Through collaboration with academic and government partners, SPoRT has successfully transitioned valuable observations and capabilities from recently launched satellites to weather forecasters. These accomplishments further SPoRT's vision to be a 'go-to' project in the applied research community to accelerate the use of next-generation satellite datasets into the operational weather community.

PROJECT MANAGERS AND/OR PRINCIPAL

INVESTIGATORS: Bradley Zavodsky and Andrew Molthan

PARTNERSHIPS: NOAA and NWS

FUNDING ORGANIZATION: Science Mission Directorate

FOR MORE INFORMATION: <https://weather.msfc.nasa.gov/sport/>; <https://nasasport.wordpress.com/>

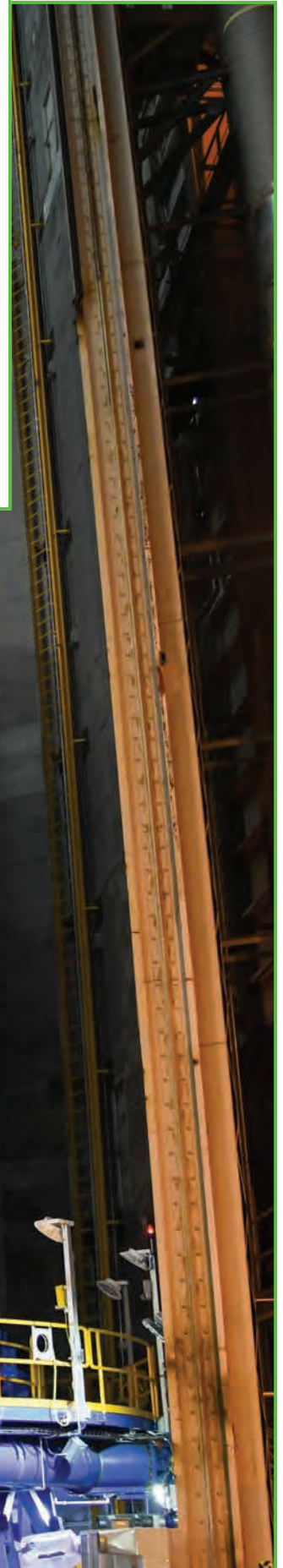

MANUFACTURING

Advances in materials, structures, mechanical systems, and manufacturing are needed to ensure that NASA and the United States remain the leaders in space exploration and scientific discovery. Innovative technologies in these critical areas are required to carry out future NASA missions and will strengthen the the US economy through applications of science and technology to the many industry that utilize these products. Such innovations can fundamentally change the way things are built and dramatically reduce the time from design to production.

Materials are the enablers behind the structures, devices, vehicles, power, life support, propulsion, entry, and many other systems that NASA

develops and uses to fulfill its missions. New materials are required—as are materials with improved properties—combinations of properties and reliability. Structures are an integral part of NASA's vision to extend exploration into deep space, requiring innovative solutions to challenging structural problems. NASA must do much more with much less, reduce overall mission loads by using materials found at destination sites, and be able to generate materials and tools on site. The novel materials and the cutting-edge additive manufacturing technologies described in the following section highlight how Marshall Space Flight Center is at the forefront of materials and manufacturing for the next generation of spaceflight and terrestrial applications.



Embedded Wireless Strain Sensors for Rapid Characterization of Structural Health

OBJECTIVE: To design fabrication and testing of a novel class of passive, battery-free, wireless strain sensors for structural health monitoring.

PROJECT DESCRIPTION

The goal of this work is to characterize structural health with wireless, passive, surface-mounted strain sensors. These sensors could reduce costs and enable rapid characterization of mechanical strain of composites and additive manufacturing (AM)-based components for space systems. The target outcome is a technology for structural health monitoring that uses lightweight sensors that might be embedded during fabrication (3D printing or layup) or added as surface mounts. This project continues to combine NASA's extensive experience in fabrication of composite structures, instrumentation for measuring mechanical strain on space structures, and testing of low-power wireless technology with academic-based efforts in electromechanical modeling.

To improve situational awareness when space objects interact, wireless strain sensors on or within the structure of a CubeSat or spacecraft would be capable of monitoring impact with space debris. As a result, this effort also aligns with Marshall Space Flight Center's (MSFC's) current efforts to participate in designing CubeSats. On Earth, the wireless strain sensors will contribute to small spacecraft-based solutions developed at low cost and on short schedules by embedding or mounting sensors to avoid the laborious, time-consuming, and expensive tasks of instrumenting test structures with wired sensors. The wireless sensors would facilitate both accelerated testing of spacecraft at low cost and improved situational awareness during flight or operation in space.

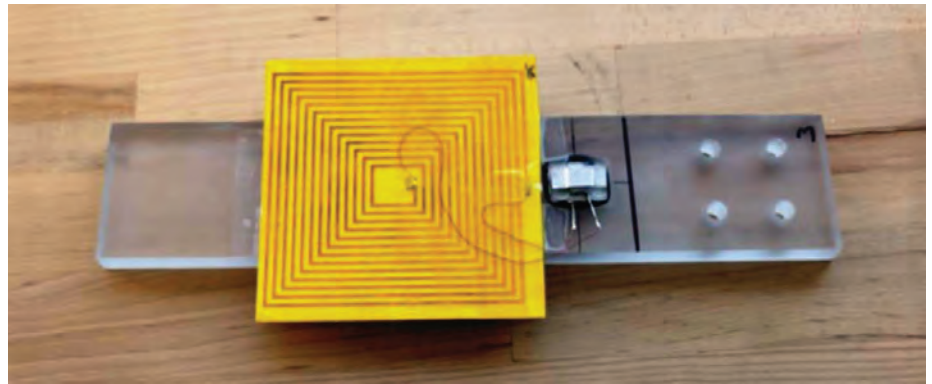

FIGURE 1. Wireless strain sensor prototype.

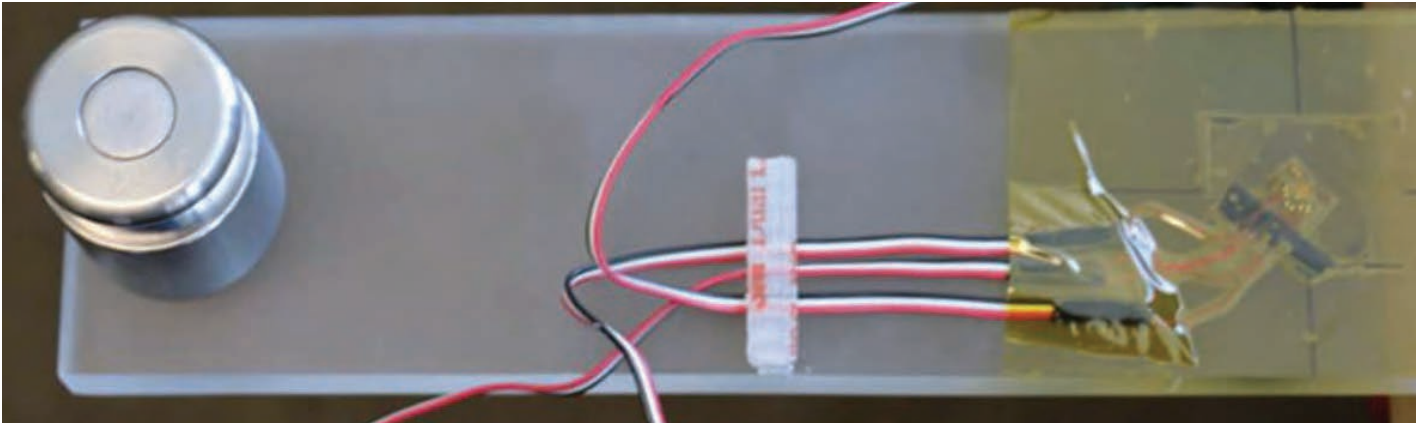

FIGURE 2. Traditional strain sensor.

ACCOMPLISHMENTS

The proposed Technology Investment Program (TIP) work was the design and fabrication of a novel class of wireless strain sensors. The uniqueness of these proposed sensors was the absence of onboard power and active electronics. Accomplishments during the project's first year include the following:

- (1) The demonstration of a wireless soft sensor.
- (2) The design and fabrication of wireless strain sensors.
- (3) Modeling and design of electromechanical components for the sensors.
- (4) Building a test platform for future in-house MSFC testing.
- (5) Initiating a New Technology Report on the work.

This concept for wireless systems consists of a reader and a sensor. Consequently, most of our work, so far, has focused on establishing the feasibility of the sensors. The sensors consist of two primary components: an inductive coil (inductor) and a sensing element (see fig. 1). We demonstrated the two types of sensing elements. The first type is for measuring high strains and uses a capacitor in series with a soft, silicone tube filled with a liquid metal called Galinstan. The second type of sensing element is for measuring low strains characteristic of structures employing metal and composite based structures. These sensing elements have required substantial research and thought, and they consist of hardware similar to those employed in AM radios.

PROJECT MANAGER AND/OR PRINCIPAL INVESTIGATOR: Patrick V. Hull

FUNDING ORGANIZATION: Technology Investment Program

In-Space Recycling and Reuse: Refabricator and Erasmus Technologies

OBJECTIVE: To develop and test the first-generation Exploration system which provides complete, integrated capabilities for sterilizing, recycling, and additively manufacturing plastic items, including food- and medical-safe implementations.

PROJECT DESCRIPTION

The In-Space Manufacturing project is developing the on-demand manufacturing systems necessary for sustainable, long-duration spaceflight missions beyond low Earth orbit. ISM has defined a technology development



roadmap that utilizes the International Space Station (ISS) as a one-of-a-kind technology demonstration testbed to ensure that these critical, on-demand fabrication, repair, and recycling capabilities are developed in a meaningful time-frame for exploration missions. These capabilities provide tangible cost savings by reducing launch mass as well as significant risk reduction due to decreasing dependence on spares and/or overdesigning systems for reliability.



The ISS Refabricator Technology Demonstration is the first integrated 3D printer and recycler system. It was developed through a Small Business Innovative Research (SBIR) Award to Tethers United, Inc. (TUI), and will be flown on the ISS in Summer 2018. This technology is the first meaningful step toward a closed-loop manufacturing system and will demonstrate the process of fabricating parts, recycling them back into useable filament, and printing new parts from the recycled feedstock. This effort is intended to minimize

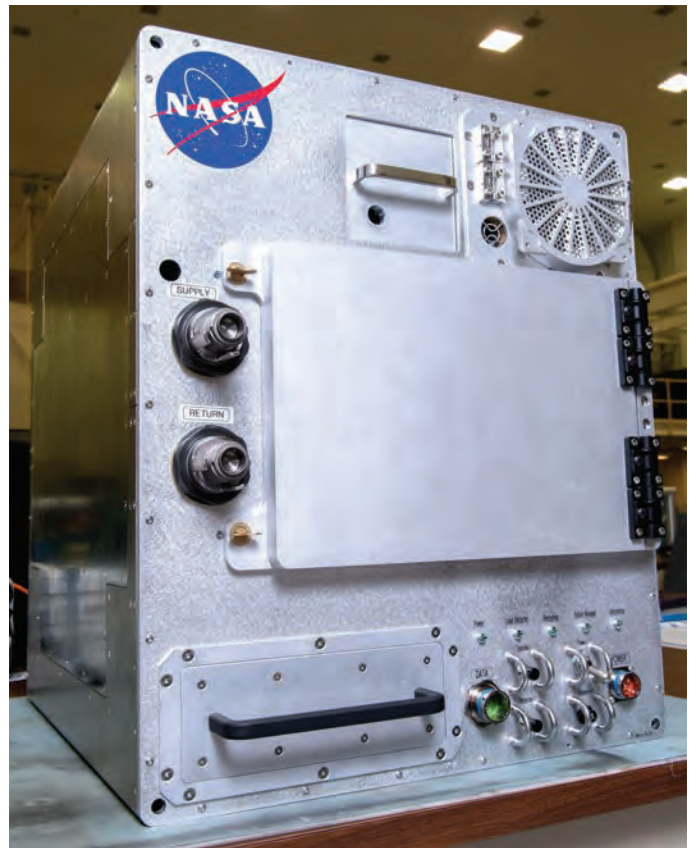

FIGURE 1. ISS Refabricator

the requirements for initial supply as well as provide a method to make new parts on-demand.

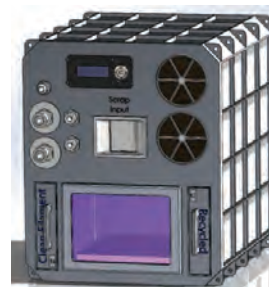

FIGURE 2. Erasmus design

Erasmus, also made possible through SBIR awards to TUI, is the next generation for closed-loop recycling during space missions and will result in the first-generation Exploration recycling system. Erasmus builds on lessons learned from the refabricator while also incorporating the additional capability of steril-

ization. Erasmus integrates a plastics recycler, dry heat sterilizer, and 3D printer to create a system that accepts previously-used plastic waste and parts, sterilizes these used materials, recycles them into food-grade and medical-grade 3D printer filament, and 3D prints new plastic implements, including those that are food- and medical-safe. The ability to sterilize plastic materials will enable the reuse of plastic materials, including food and medical items that are typically trashed after a single use, without worry of bacterial or viral contamination. The ability to recycle/reuse food containers and implements, as well as medical implements, significantly decreases the amount of trash produced, while greatly increasing useable feedstock for manufacturing new and/or different items. Additionally, this capability also enables feedstock production from multiple types of packaging materials such as foam, bubble wrap, and plastic bags.

ACCOMPLISHMENTS

This year marked the development of the actual refabricator flight hardware in preparation for launch to the ISS. Additionally, the project team developed integrated, sterile 3D printing and recycling technology, which resulted in the production of a breadboard prototype. During 2017, the members of the project team completed multiple studies on various thermoplastic material designs, which included evaluating any deg-

radation relative to multiple recycling cycles. The team also participated in the design efforts of the NASA Logistics Reduction project that seeks to fabricate and recycle sanitized and/or sterile items.

SUMMARY

NASA Applications:

These in-space recycle-and-reuse technologies can be used on the ISS and on future long-duration crewed missions as a means to promote astronaut health and safety, as well as decrease mission cost and waste generated by providing a way to create needed parts while in space. This results in meaningful cost and schedule savings by printing parts on-demand from readily available materials. These are the capabilities required for Earth-independent spaceflight missions and sustainability of crewed off-Earth habitats.

Non-NASA Applications:

These recycling and reuse technologies have significant potential for broad commercial infusion into terrestrial applications and markets. The implications for increasing sustainability and decreasing waste of objects such as packaging, water bottles, plastic shopping bags, etc. is substantial. TUI has developed a commercialization plan for these capabilities.

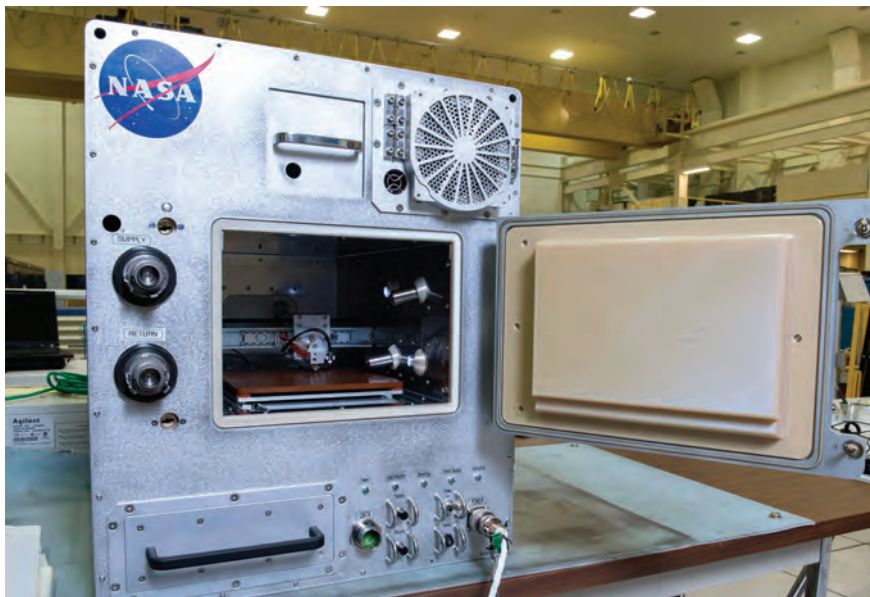

PROJECT MANAGER: Niki Werkheiser
FUNDING ORGANIZATIONS: Advanced Exploration Systems; Game Changing Development
FOR MORE INFORMATION: http://www.nasa.gov/mission_pages/station/research/news/3D_in_space

In-Space Manufacturing (ISM) Multimaterial Fabrication Laboratory (FabLab)

OBJECTIVE: To develop and demonstrate a multi-material fabrication laboratory (FabLab) capable of end-to-end manufacturing during space missions. The In-Space Manufacturing (ISM) FabLab will be demonstrated on the International Space Station and will serve as the first step toward a fully integrated, on-demand manufacturing capability that is able to produce finished, ready-to-use products for Exploration missions.

PROJECT DESCRIPTION

In order to sustainably live off Earth, crews must have the ability to manufacture and repair components and systems on-demand. In providing this capability, the In-Space Manufacturing Multimaterial Fabrication Laboratory (FabLab) changes the traditional paradigm of launching all necessary materials and their spares from Earth. NASA's Advanced Exploration Systems division and Space Technology Mission Directorate are investing in this key technology via Next Space Technologies for Exploration Partnership (NextSTEP), a program that provides public-private partnerships to enable commercial development of deep space exploration capabilities to support human spaceflight missions in cis-lunar space and beyond.

The FabLab project builds on previous success with 3D printing of plastics on the ISS in 2014 as well as commercial development of several additive manufacturing technologies. This project seeks to expand the Station's on-demand fabrication capability by increasing the number of printable materials (feedstock) available while improving overall manufacturing efficiency. The FabLab payload goal is to demonstrate an end-to-end manufacturing process using multiple materials, includ-



FIGURE 2. Logo for the Next Space Technologies for Exploration Partnership (NextSTEP). The ISM program is part of the program.



FIGURE 1. Mission logo for the In Space Manufacturing program.

ing metals. This includes the capability to 3D print with metals.

The FabLab capability will be developed in three phases. The objective of Phase A is to demonstrate scalable ground-based prototypes designed to be compatible with the International Space Station (ISS) Expedite the Processing of Experiments to Space Station (EXPRESS) rack and capable of remote operation from Earth. The objective of Phase B is to further mature the technology towards flight qualification. Phase C will be an ISS technology demonstration to prove the printing method in consistent microgravity, define the parameters necessary for optimized printing in space, fully characterize the printed material, and fabricate usable components for the ISS. Demonstration of the FabLab on the ISS will lead to future manufacturing systems for deep space habitats and transit vehicles.

ACCOMPLISHMENTS

Phase A proposals were solicited under Appendix B of the “NextSTEP-2 Omnibus Broad Area Announcement.” The solicitation closed in September 2017 with 16 responses. The following responses were evaluated for suitability in the following target capabilities:

- The system must provide for on-demand manufacturing of multiple materials in microgravity—including, but not limited to, aerospace-grade metals, polymers, composites, and digital inks—for the fabrication of electronic components.
- The design must meet ISS EXPRESS rack operational constraints and maximize build volume (must be greater than a 6-in cube).
- The system must incorporate Earth-based remote commanding and/or autonomous capability for all nominal, maintenance, off-nominal tasks, including part removal and handling.
- The system must incorporate remediation capability for defects identified during an in-line quality control process.

Following evaluation of the responses via a large review team populated by project management and subject matter experts, the core review team down-selected responses for recommendation for funding. These recommendations were evaluated by NASA Headquarters. Once announcements regarding the responses selected for funding occurred, the phase A selectee(s) were given 18 months to deliver a prototype once a contract award is made.

SUMMARY

Sustainable exploration of the solar system requires the ability to manufacture and repair with readily available materials. In line with the NextSTEP program goals, NASA will utilize a public-private partnership to provide the capability of manufacturing—with metals and other materials—items for use on the ISS in preparation for next-generation systems to be deployed on deep space missions. The FabLab will be the first demonstration of printing with metals in space and will provide the capability of on-demand, end-to-end manufacturing to design specification. The ability to produce parts and components on-demand during missions will significantly reduce logistics mass in the form of spares, mitigate risk, and enable exploration without dependence on Earth.

PROJECT MANAGER: Niki Werkheiser

FUNDING ORGANIZATIONS: Advanced Exploration Systems; Game Changing Development

FOR MORE INFORMATION: <https://www.nasa.gov/feature/nasa-seeks-fablab-concepts-for-in-space-manufacturing>



Toward In-Space Additive Manufacturing of Thermosets With Embedded Fibers

OBJECTIVE: To overcome the operating temperature limits of currently employed thermoplastic materials by developing extruded printing of thermoset materials with embedded fibers.

PROJECT DESCRIPTION

To produce parts in space for repairs, instrumentation, or convenience (e.g., an astronaut recently requested a 3D-printed back scratcher), we use fused deposition modeling (FDM) for the extrusion of thermoplastics through a nozzle from reels of ribbon-like feedstock. This process is adequate as a proof of concept, helps us understand the economic and physical requirements for in-space additive manufacturing (ISAM), and will lead to useful applications for spacecraft; however, FDM with thermoplastics will always be limited by the fundamental physical issue that a material formed through melting will deform again if exposed to temperatures similar to those used during forming. In other words, improvements in high-temperature properties of thermoplastics require materials with high glass-transition temperatures and high processing temperatures, which can result in a cycle of continual development of processing machines that require operation at higher and higher temperatures. This research work is focused on modeling and testing extruded thermosets in a controllable fashion with fast thermal curing of the material to control the lateral spreading and limit the resolution of printable features.

ACCOMPLISHMENTS

The benefits from the work this year are demonstrated in the development of an experimental and theoretical platform that serves as a springboard for further research and additional funding for long-term development of ISAM and computer-aided manufacturing (CAM) with thermal-curing thermosets. The resulting work has allowed the exploration of the physical tradeoffs between gravity, curing kinetics, surface tension, viscosity, size of the extruding nozzle, rate of deposition, motion of the nozzle, and composite fiber properties. The anticipated benefits from this work are the creation of design rules for building future machines, selecting appropriate thermal-curing ther-

mosets for ISAM of high-performance materials and structures, and developing the first extruded thermoset additive manufacturing (AM) machine. Future machines based on this technology are expected to bridge the gap between producing geometrically sound features and extruding materials with suitable strength and thermal endurance for use in space structures. In summary, this work has matured advanced AM for future in-space applications.

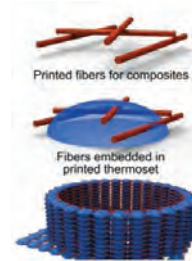

FIGURE 1. Simulated thermoset embedded fiber.

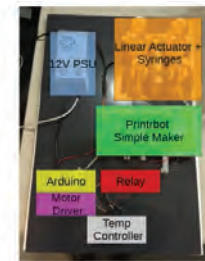

FIGURE 2. Extruded thermoset printer layout.

The following are technological advancements since the beginning of FY2016:

- Model the spreading and extruding behavior of non-curing, Newtonian liquids.
- Characterize contact angle and spreading of curing droplets on a heated surface.
- Build and test a prototype AM machine for thermosets.
- Use calibrated models to predict performance in varied-gravity environments (in work).
- Include elasticity of extruded thermosets in models.
- Perform optimization with the physical models to improve the quality of extruded droplets, puddles, linear beads and composite fibers (in work).
- Mechanical testing of extruded features (in work).

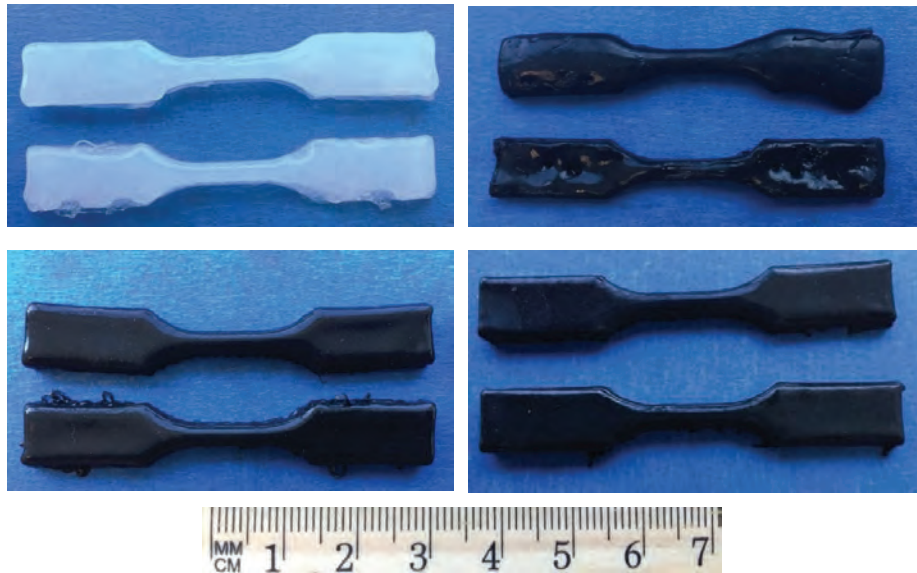

FIGURE 3. Dog bone samples. All dog bone samples were printed using the same GCode. From left to right, top to bottom, 0% with 0.01-in tip, 5% with 0.016-in tip, 10% with 0.01-in tip, 15% with 0.016-in tip. The print speed for all samples was 30 mm/s.

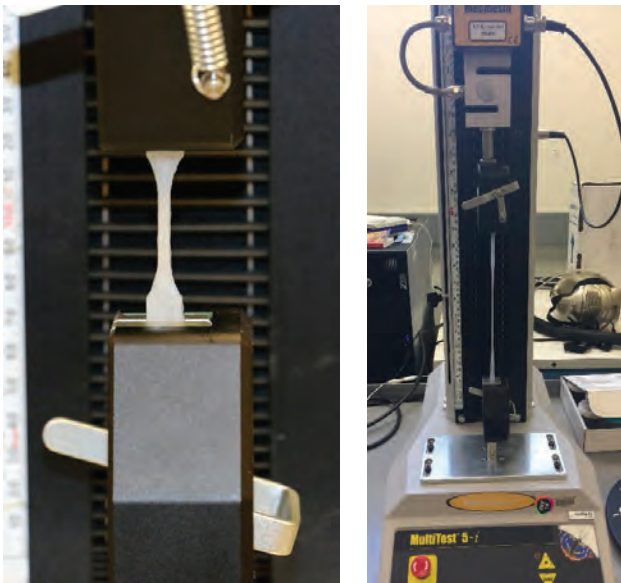

FIGURE 4. Tensile testing machine. Left: A dog bone of pure Ecoflex™ loaded onto the MecMesin Multitest 5-I before stretching. The right image depicts the same sample stretched nearly 250 mm past the original point.

SUMMARY

Current ISAM relies on fused deposition modeling (FDM) of thermoplastics, such as acrylonitrile butadiene styrene, which have limited mechanical performance (e.g., thermal stability up to ≈ 100 °C, yield strength less than 70 MPa, and an elastic modulus less than 3 GPa). To overcome the operating thermal and mechanical limits of currently employed thermoplastic materials, we are studying and characterizing extruded printing of thermosets with embedded fibers. The target outcome is an experimental and theoretical platform with an AM-based machine on earth and accompanying numerical simulations, which will then be capable of predicting performance in low- or high-gravity environments.

PROJECT MANAGER AND/OR PRINCIPAL

INVESTIGATOR: Patrick V. Hull

FUNDING ORGANIZATION: Center Innovation Fund

3D-Printed Electroluminescent Light Panels

OBJECTIVE: To develop the materials and techniques necessary to 3D print electroluminescent light panels.

PROJECT DESCRIPTION

The motivation of the proposed work was to expand the capabilities of multimaterial 3D printing, as there were no established processes for printing light-emitting devices. Electroluminescent (EL) devices were the most logical option for a 3D-printed light source since the materials and construction needed are relatively simple and forgiving compared to that of semiconductor-based devices such as LEDs. Having the ability to print light sources will offer a wide array of applications, as these devices will be embeddable in many surfaces and can be used in similar fashions to LEDs. Adding capabilities like this to a potential multimaterial 3D-printing suite would allow one machine to be able to additively manufacture solutions relevant to the demands of many different applications. This development would be a step towards a comprehensive machine that could truly 3D print anything necessary on demand, whether it be electronics, structures, lighting, etc. In the interim, the goal of this project was to create the inks and processes for EL devices that can be 3D printed and embedded onto many surfaces. This concept was incubated during previous discussions with the Office of Chief Technologist, where the desire was to embed identification patches on astronaut spacesuits so that, at a glance, astronauts could identify other astronauts in their suits. This is particularly important in the Martian environment where dust storms are frequent.

ACCOMPLISHMENTS

The innovative aspect of this proposal lies chiefly in the ability it will grant to print on-demand light sources scalable to the need of the situation. This innovation will make it more possible to bring only inks and a printer to a new location (ISS, Mars, etc.) and still have the necessary capabilities to print solutions to many problems that may arise, at a drastically reduced up-mass. Tasks it would accomplish include printing all necessary lighting for a habitat, printing indication lighting, embedding lighting in other printed structures, and eventually printing displays on demand. However, in order to do this, innovations needed to be made in

ink development, specifically in the development of the crucial transparent conductor ink, which was the existing technology gap. This ink was to be created using a process that has been demonstrated to work by creating transparent, conductive sheets of indium tin oxide through a particle-free process.

The four research goals for this project were:

- (1) Integrate dielectric materials developed at Marshall Space Flight Center (MSFC)—which can be 3D printed and provide higher luminosities because of their higher permittivity—into current EL screen-printing technologies.
- (2) Develop a transparent conductor ink to bridge the existing technology gap.
- (3) Develop techniques for printing these devices entirely out of the developed materials.
- (4) Print an EL device and demonstrate scalability as a deliverable for the project.

The proposed activities of year two will focus on building upon the first-year activities to create inks and processes to make entirely transparent 3D-printed EL devices. The main barriers to this are a good transparent conductor (which was addressed in year 1, and suitable candidates were identified), the development of a high-permittivity, transparent dielectric material, and the development of a transparent phosphor ink. Transparent phosphors have been achieved, and some effort will be spent on making a viable ink. Such a device would be incredibly innovative, as it would open new doors for applications such as displays, signs, and windows that are transparent when not energized. Potentially, the most exciting application is using existing methods for the production of nontransparent EL based displays to create transparent EL displays with this new technology. An advancement such as this could be paradigm changing to the realm of cell phones, computers, and even newer areas like heads up displays and augmented reality.

During the past year, the team was able to accomplish all four goals with varying degrees of success. The first

goal of using MSFC materials to increase performance was accomplished by replacing the off-the-shelf dielectric material with a high-permittivity material that was originally developed for the Ultracapacitor project. This resulted in a lowering of the turn on voltages of the devices (from ≈ 120 VAC down to ≈ 80 VAC), which is significant because it lowers the operating voltages of these devices into a range where they pose



FIGURE 1. Screen-printed EL device made with MSFC dielectric.

less high-voltage risk to humans (shown in fig. 1). The second goal of creating a transparent conductor ink was accomplished by using a method outlined in reference 1. Unfortunately, while this method proved effective for creating highly transparent, conductive films under highly specific, controlled conditions, prints that were done using this method onto surfaces necessary for making EL devices proved to be unusable. Because of this, a substitute commercially available ink was used instead; this ink is much less transparent but can be consistently printed, which was necessary for the completion of goals 3 and 4.

The final two goals of this first year involved developing the processes and any materials necessary for 3D printing EL devices. These devices were made on an nScripT (microdispensing) printer to make as opposed to an aerosol-jet printer (as was originally proposed). This was because the nScripT printer is capable of printing the screen printer inks used/developed for the devices in goal 1, so it was better able to handle the materials as-is and did not require any adaptations. Using this printer, goals 3 and 4 for this project were accomplished by successfully printing several different designs of devices which demonstrated the scalability and versatility promised by 3D printing. Two devices—one printed on ceramic and one printed on quartz—are shown in figures 2 and 3. The demonstration of these devices will pave the way for the printing of more complex devices in the future, including EL signage, displays, and entirely transparent devices.

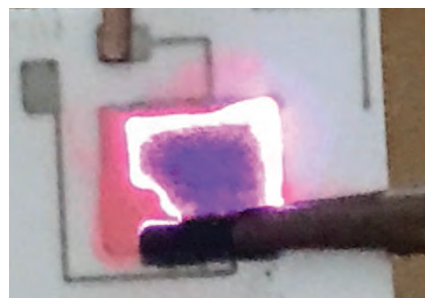

FIGURE 2. 3D-printed EL device on ceramic.

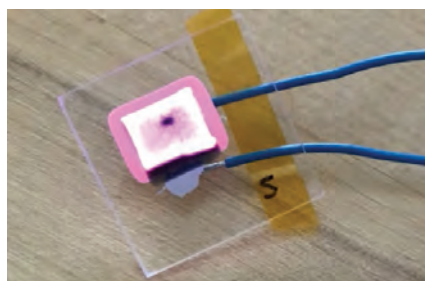

FIGURE 3. 3D-printed EL device printed on quartz.

SUMMARY

Over the course of the first year of this research and development effort, many accomplishments were made toward developing the materials, processes, and techniques needed for 3D printing improved EL devices. In this year, we demonstrated the benefit of using advanced MSFC materials, our ability to create on-demand materials, and our ability to ultimately 3D print EL devices which will open the door for creating more exotic devices using similar techniques that were developed. This leads into our second-year effort, where we will attempt to develop the necessary materials for creating entirely transparent EL devices.

REFERENCE

1. Fang, M.; Aristov, A.; Rao, K.V.; Kabashin, A.V.; Belova, L.: "Particle-free inkjet printing of nanostructured porous indium tin oxide thin films," RSC Adv., Vol. 3, No. 42, pp. 19501–19507, 2013.

PROJECT MANAGERS AND/OR PRINCIPAL INVESTIGATORS: Ian Small (PI), Terry Rolin (Co-PI), Angela Shields (Co-PI)

FUNDING ORGANIZATION: Center Innovation Fund

Ionic Polyimides: New High-Performance Polymers for Additive Manufacturing

OBJECTIVE: To determine the relationship between molecular structure, thermal and physical properties, and performance of ionic polyimides.

PROJECT DESCRIPTION

A team of researchers at NASA Marshall Space Flight Center (MSFC) seeks to determine the utility of ionic polyimides as materials suitable for additive manufacturing (AM) of components used in aerospace vehicles, with an emphasis on characterizing and simulating their thermal behaviors and properties. This proposal addresses the need for fundamental research on a customizable polymer filament feedstock for 3D printing with tailor-made properties, potentially making it superior to the commercial blends offered in industry today. The deliverables for this project are the creation of a database that will detail the relationships between the molecular structure and physical properties for the ionic polyimide of interest (e.g., glass transition



FIGURE 1. Photographs of the first-generation ionic polyimide films: (a) neat and with ≈ 25 wt% 'free' $[\text{C}_2\text{mim}][\text{Tf}_2\text{N}]$ content and (b) the difference in optical clarity when 'free' IL is present illustrated.

temperature/melting point relative to different ionic polyimide structures). This new database will lead to the development of the first generation of materials and, ultimately, proof of concept.

ACCOMPLISHMENTS

The proposal is a continuation and aligns with the Advanced Manufacturing FY2017–2018 Focus Domain. This research will focus on AM to develop in-space manufacturing capabilities for space exploration. The innovation is revolutionary because, unlike any material currently available for 3D printing, ionic polyimides retain the robust nature of polyimides while displaying the ease of processing and conductivity of ionic liquids (ILs). Figure 2 shows an example structure of an ionic polyimide produced from commercially available starting materials by a research group led by Professor Jason E. Bara at The University of Alabama.

The unique combination of functionalities and properties is not found in conventional polyimides or other engineering polymers. The use of these materials will allow for potential aerospace applications such as valves, O-rings, seals, and gears. Bara's group has already demonstrated that their first-generation ionic polyimides can be extruded, pelletized, and molded at ≈ 220 °C, which is consistent with modern fused deposition modeling (FDM) 3D printers (fig. 3).

Beginning to rapidly elucidate the thermal behaviors of these materials is imperative to gaining an understanding of the key structural variables that must be manipulated to develop further generations of application-specific materials. The benefits associated with ionic polyimides are the following:

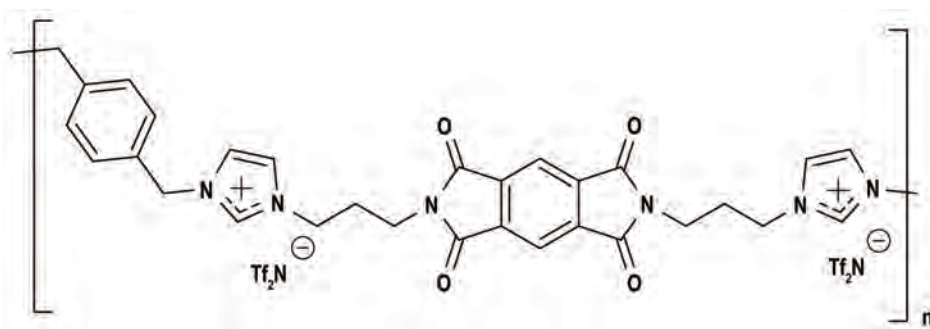

FIGURE 2. Example of ionic polyimide molecular structure.

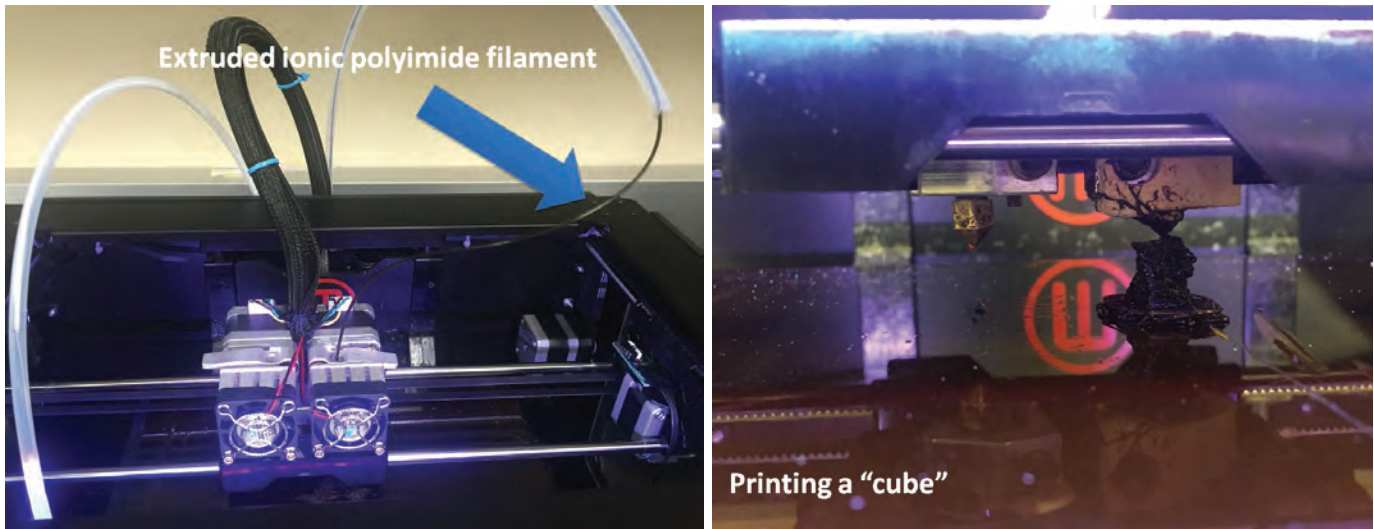

FIGURE 3. Proof of concept in using ionic polyimide material in FDM 3D printing.

- Better control over chemical, conductive, and mechanical properties during the production of polyimide materials.
- Ability to bind ILs within their structures, allowing for enhanced control of material properties and performance.
- Straightforward synthesis/production process.
- Results in low-cost fabrication.
- Finished material that would likely garner a premium price due to the enhanced material functionality.

Presently, the researchers at MSFC have received and characterized nearly 20 ionic polyimides synthesized by the Bara Research Group at The University of Alabama (UA). To date, the researchers have conducted a differential scanning calorimetry (DSC) analysis and a Fourier transform infrared-spectroscopy (FT-IR) analysis on polymers and their respective building blocks to determine the thermal properties of each sample, and the relative abundance of the elements/molecules in each sample. Also, we have modeled eight of the building blocks using the Gaussian 16 and Spartan 16 simulation packages.

As a continuation of their previous work, the team is venturing into modeling the polymer building blocks to more rapidly identify viable ionic polyimide configurations (i.e., polyimides with the correct thermal, chemical, and physical properties for 3D printing). The team plans to use data collected in the first year Center Innovation Fund to anchor the model we are develop-

ing in this proposal to correlate synthesis and thermal characterization of these polyimides. These data will allow for selection of the most promising materials for scale up, from which we will then extrude filaments for use in FDM 3D printing.

Resources for this effort will be used to collaborate with the Co-PI Professor Jason Bara from UA, and Kendall Byler a computational chemist from The University of Alabama in Huntsville (UAH). Jason Bara and his research group, will continue to synthesize ionic polyimides and begin to extrude filaments. Byler will continue to conduct molecular dynamic simulations of each of the polyimide structures.

SUMMARY

The researchers continue to synthesize different variations of these ionic polyimides and characterize these polyimides with different thermal characterization techniques, namely DSC and FT-IR.

We will also continue modeling ionic polyimides via ab initio calculations. Finally, we will develop filament feedstock materials from these ionic polyimides and ILs to additively manufacture parts from these materials for aerospace applications.

PROJECT MANAGER/PRINCIPLE INVESTIGATOR:
Enrique Jackson, MSFC

PARTNERSHIPS: Jason Bara, The University of Alabama; Kendall Byler, The University of Alabama in Huntsville

FUNDING ORGANIZATION: Center Innovation Fund

Space Environmental Effects on Additively Manufactured Parts

OBJECTIVE: To modify space environment simulators for higher fidelity to actual space environment and characterize the improved performance by testing additively manufactured materials samples.

PROJECT DESCRIPTION

A 3D printer was installed on the International Space Station (ISS) in 2014 and has printed over two dozen parts. This technology is maturing with stronger materials, including rocket engine parts that, for an Exploration mission, may be exposed to space for weeks and months, not just minutes. Eventually, either on ISS or on manned missions elsewhere in the solar system, a part exposed to space will need to be replaced. This effort gives the data needed on how durable 3D-printed materials might be in the space environment. During the 3D-printed part testing, improved ultraviolet (UV) radiation sensors were also exposed, and the UV radiation simulator was better characterized. One of the UV radiation sensor designs has been selected to fly as part of the Materials International Space Station Experiment 9 (MISSE-9) array of experiments.

ACCOMPLISHMENTS

Expanding on last year's testing, more polymeric samples were exposed to simulated low-Earth-orbit atomic oxygen and UV radiation. The technology advanced from no data available to test readiness level 5 (TRL-5) for electrostatic-dissipative polyetherketoneketone (ESD-PEKK), polycarbonate biocompatible per ISO 10993 USP Class VI (PC-ISO), and polyphenylsulfone (PPSF). Data from these tests led to the selection of Inconel, Ultem 1010, Ultem 9085, and ESD-PEKK for flight on MISSE-9 wake side (fig. 1). The improved UV sensors will be flown on the ram, wake, and zenith sides. In addition, space on the nadir side of MISSE-10 was awarded for a duplicate set of additively manufactured samples. This side has much less exposure to atomic oxygen and UV radiation but will have thousands of thermal cycles in hard vacuum over the expected year in space.

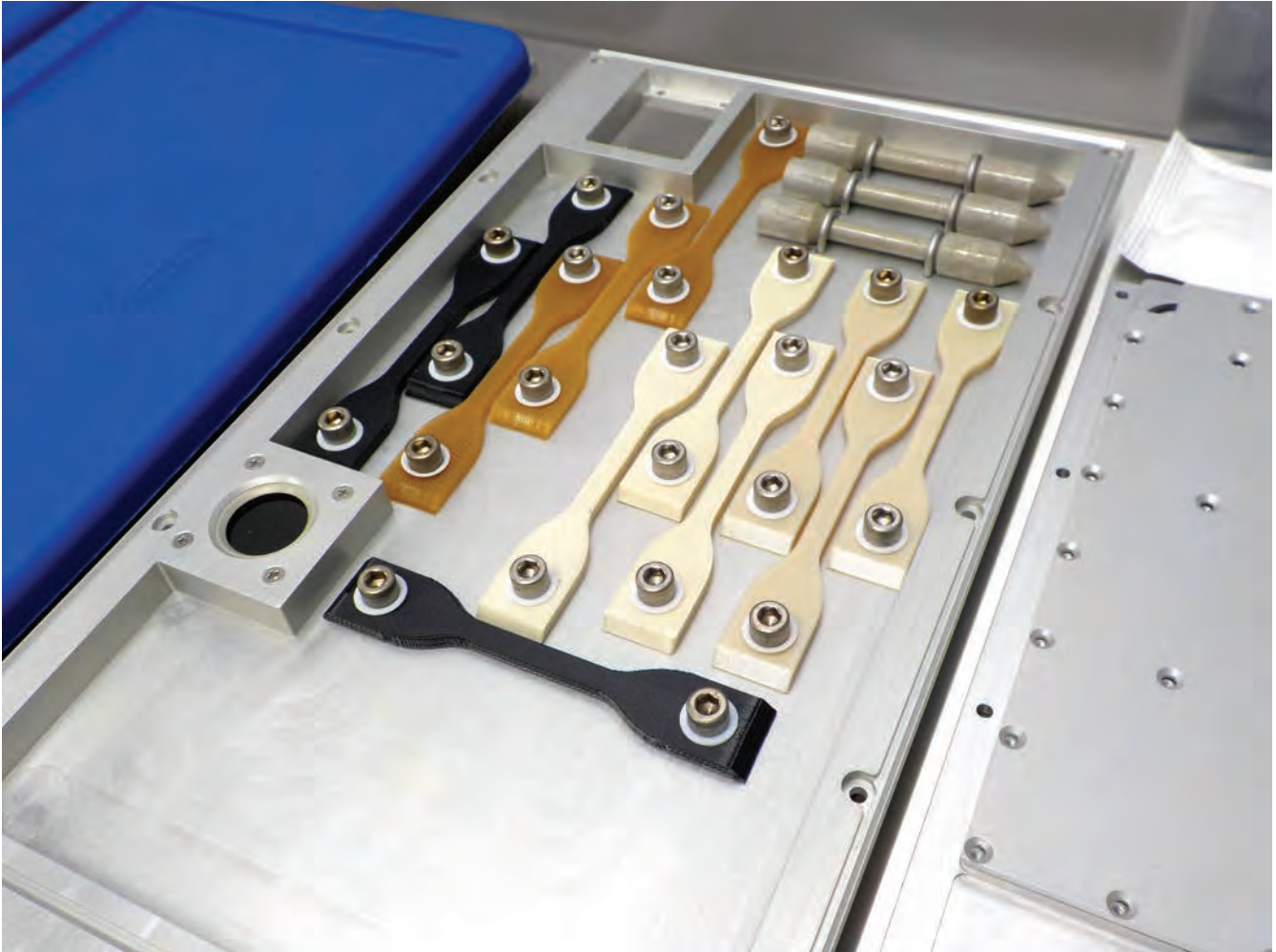

FIGURE 1. UV sensor and additively manufactured polymeric and metallic samples assembled for MISSE-9.

SUMMARY

As part of Living and Working in Space, this effort helps develop in-space manufacturing capabilities and advance towards more sophisticated parts. The new UV sensors are small enough for flight, not only on MISSE-FF but also CubeSats.

PROJECT MANAGER AND/OR PRINCIPAL INVESTIGATOR: Miria Finckenor

FUNDING ORGANIZATION: Technology Investment Program

Void Optimization Laser-Ultrasonic Additive Manufacturing Test Utility System (VOLATUS)

OBJECTIVE: To develop a 3D dynamic assessment tool for evaluating additive manufacturing print quality using laser-ultrasonic technology.

PROJECT DESCRIPTION

With current selective laser melting (SLM) and fused deposition modeling (FDM) additive manufacturing (AM) processes, part builds can well exceed 30 days to complete with no insight on build quality, layer adhesion, voids, defects, material density, or thermal boundaries. The goal of this project is to evaluate laser ultrasonic technology as an in-process scanning tool to evaluate build and material properties.

ACCOMPLISHMENTS

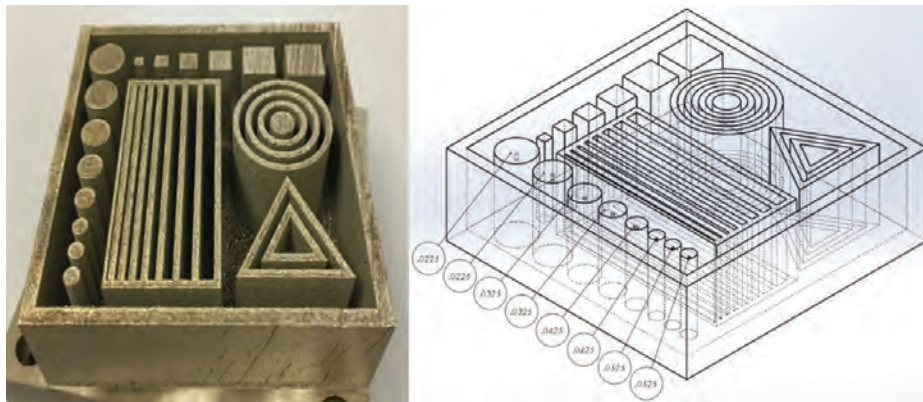

FIGURE 1. CAD model and SLM IN-718 build showing subsurface defects.

The project was divided into three proof-of-concept stages to allow modularity of the scanning platform, evaluation of current technologies, and final integration to current capabilities. The first challenge was to develop a gantry system that was open source in its mechanics, electronics, and controls. These components were important to understand its operation and flexibility in mounting alternative laser scanning technologies. All gantry frame parts would have to be easily purchased or manufactured using common AM processes. The second challenge was to test out different scanning technologies and evaluate the data based on speed of acquisition, accuracy, and precision. The different tech

nologies evaluated were laser ultrasonics with Optech Ventures, diffuse laser scanning, and laser profilometry. The last challenge was to integrate a diffuse laser sensor into the gantry and evaluate data being received. Data was meshed from rotary encoders and the diffuse laser measurements, which generated a 3D model. If an ultrasonic laser was used, data would include defect reflection information. The information received from these in situ scans could be integrated into predictive materials properties and failure models.

The XYZ gantry system is based on an open source design using AM parts and readily available materials.

This design was chosen based on the availability of commercial-off-the-shelf (COTS) materials, the ease of adaptation to mount different sensor heads, and the flexibility of control and data acquisition software. The gantry was designed for a scan region of $24 \times 24 \times 12$ in (length \times width \times height). A part with features often challenging for AM was developed with subsurface voids and built in multiple process types and materials to include SLM Inconel 718,

FDM acrylonitrile butadiene styrene (ABS) and FDM polylactic acid (PLA) (see fig. 1). These materials were chosen based on their frequency of use in the aerospace and in-space manufacturing (ISM) communities. With all of the technologies evaluated, one of the greatest challenges was data processing. Sampling rates for many of the sensors exceeded 100 kHz during the scan which presented a tradeoff between scan duration, scan area, resolution and interpretation of large file sizes. To strike a balance, speeds were increased to the point of maintaining a high resolution while reducing the scan file size and therefore minimizing the impact to the AM build process.

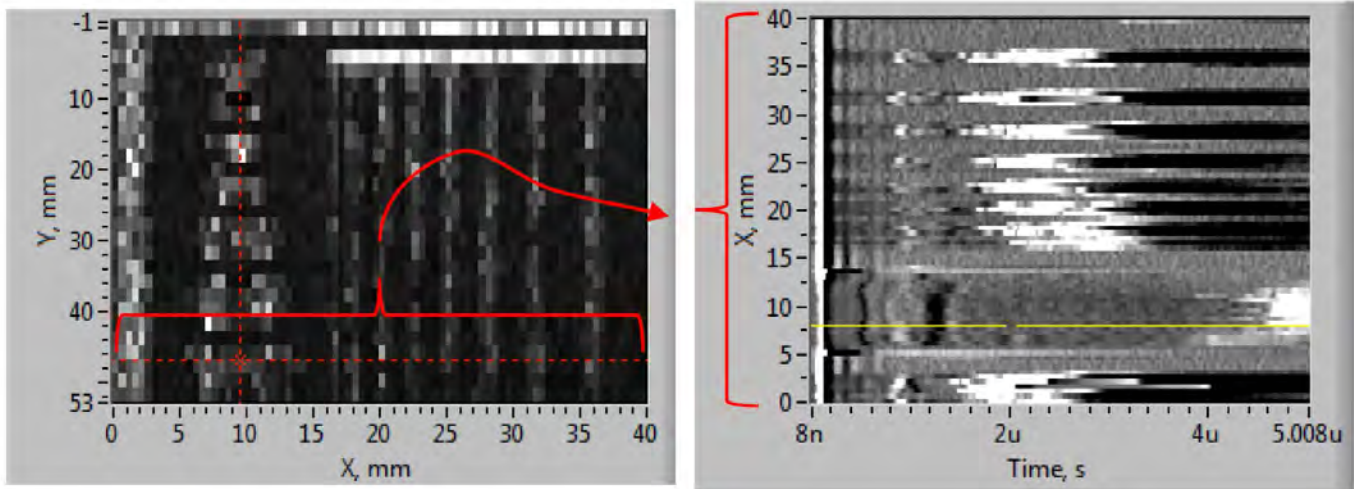

FIGURE 2. B-scan from C-scan showing defect on largest cylinder.

SUMMARY

Laser ultrasonic scan technology resulted in promising data capable of detecting material boundaries and subsurface flaws to depths greater than 0.0525 in. Figure 2 is a B-Scan (x -direction) from a C-Scan (x - and y -direction) showing defect detection on the largest cylinder (top left) of the SLM printed part. Challenges that require more investigation include reducing the distance between the generation beam and detection beam, streamlining data processing to be integrated into real-time decision making, and optimizing scan frequency per layer of build.

PRINCIPAL INVESTIGATOR: Andrew C. Chaloupka

PARTNERSHIP: Optech Ventures, LLC

FUNDING ORGANIZATIONS: MSFC Innovation Day Shark Tank



Additive Manufacturing Cleaning Process Improvement

OBJECTIVE: To develop a cleaning process to remove additive manufacturing (AM) remnant powder prior to precision cleaning and post-process treatments.

PROJECT DESCRIPTION

Additive manufacturing (AM) is revolutionizing the way the world fabricates components and is paramount to the future of space exploration. This project focused on a means to eliminate the 10–100 micron-sized remnant powders that remain following AM. The presence of any unincorporated powder within the component directly affects any post-processing steps—i.e., stress relief and hot isostatic processing (HIP)—while the presence of powder in liquid oxygen systems is prohibitive due to the high likelihood of a particle ignition event. Standard cleaning methods that utilize vacuum, percussive forces, compressed air, and carbon dioxide (CO₂) snow work on direct-line-of-sight surfaces, but are not effective for internal/recessed cavities.

Computed tomography (CT) scans of four ‘as received’ and ‘doped’ AM engine components certified the presence of 12 entrapped areas of powder, primarily in the central interior cavity. Following the use of a new, innovative cleaning process developed by NASA, all but one area of powder was completely removed. The one outlier was attributed to process variables that could not be addressed by the prototype system.

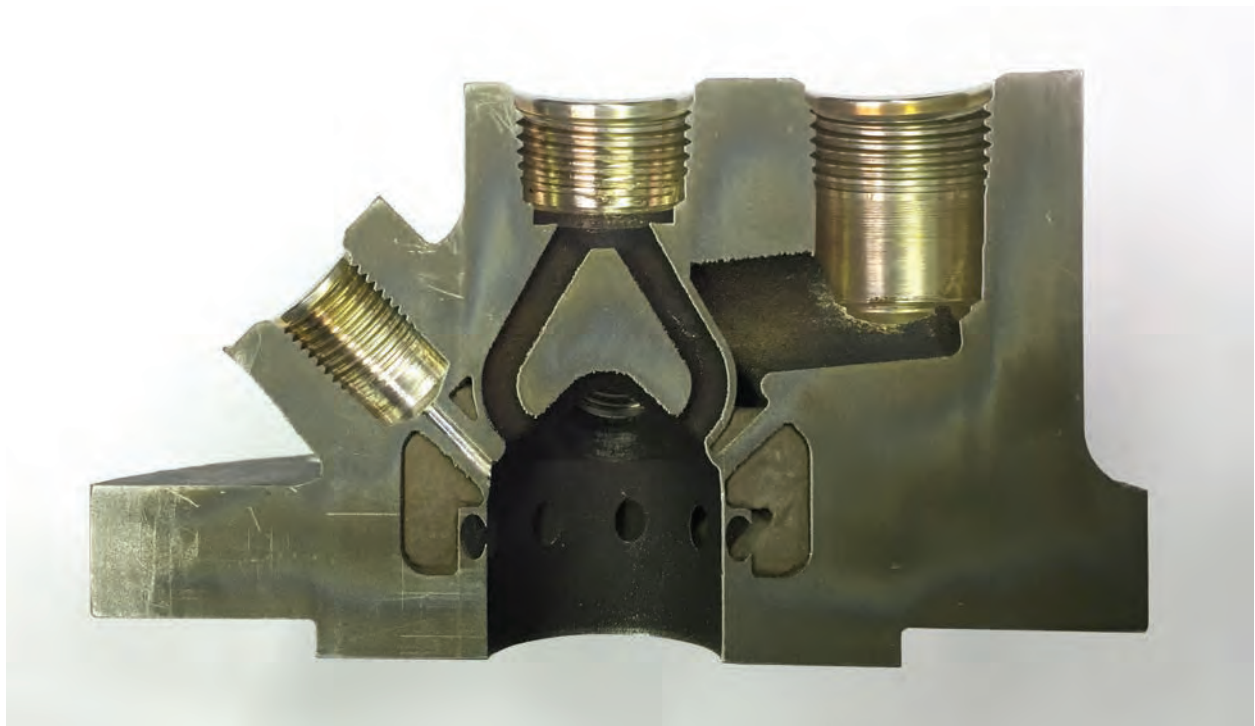

FIGURE 1. AM engine component. Internal chamber became plugged following HIP treatment without proper AM powder removal.

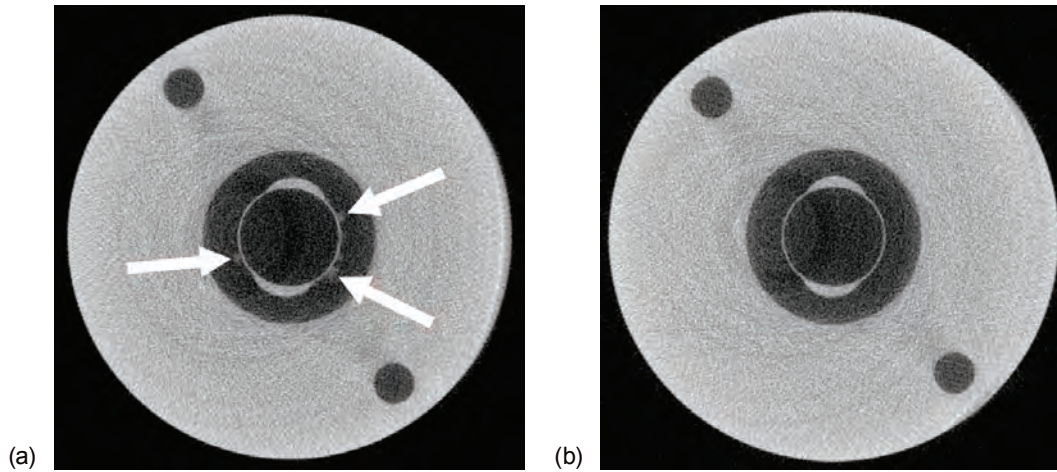

FIGURE 2. Mid-section CT scan (a) prior to cleaning with three distinct locations of powder accrual and (b) post-clean, whereby powder has been successfully removed.

ACCOMPLISHMENTS

The successful test has since led to a Technology Investment Proposal award and the submittal of a New Technology Report for patent review. An industrial system is currently being designed and manufactured to support Marshall Space Flight Center’s (MSFC’s) AM work. This new system is planned to support existing MSFC AM build plate sizes. The time required to remove remnant powder with 100% confidence will significantly be reduced and will insure that remnant powder does not affect the overall cleanliness or quality of the component. This new system, slated to be completed in 2018, will be designed to incorporate additional cleaning options and the ability to process components of various geometries.

SUMMARY

AM has enabled the ability to create a complex 3D object within a single piece manufacturing operation that was not possible in the past. Current designs are hindered by the fact that removal of entrapped powder remains a gating design item. The implementation of a cleaning method to remove the entrapped powder will only serve to increase the designer’s capability of what may be manufactured.

PROJECT MANAGERS AND/OR PRINCIPAL INVESTIGATORS: Mark Mitchell, Kevin Edwards

FUNDING ORGANIZATION: MSFC Innovation Day Shark Tank

Characterizing Effects of Potential Build Induced Defects in Selective Laser Melting Components

OBJECTIVE: To evaluate the effect of ‘witness marks’ on additive manufactured aluminum parts made via selective laser melting (SLM).

PROJECT DESCRIPTION

‘Witness marks’ are horizontal lines that are a result of the powder bed fusion-build process. It is often thought that these are indicative of poor build quality and considered by some to be grounds to scrap a build; however, there is no evidence to warrant such a perception. The main goal of this project was to establish the effects of witness marks generated by build pauses on operational characteristics of additive manufacturing (AM) components produced through the selective laser

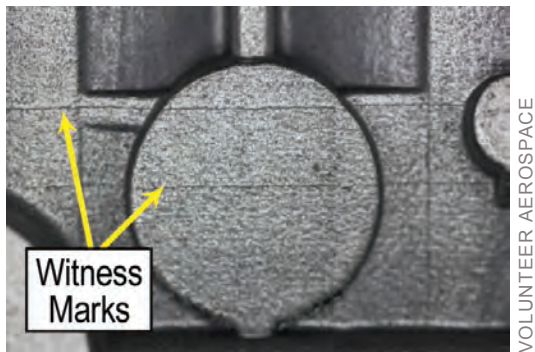

FIGURE 1. SLM component with witness marks.

melting (SLM) process. Results provide a more quantitative success/failure criteria to accurately assess build issues and show the potential to improve build success rate, reduce production costs, and facilitate flight certification.

ACCOMPLISHMENTS

Numerous specimens were produced through SLM following a process developed by Marshall Space Flight Center (MSFC) on the Concept Laser X-Line 1000R for IN718. This process was repeated using the Volunteer Aerospace, Inc., (VAI) x-line using AlSi10Mg.

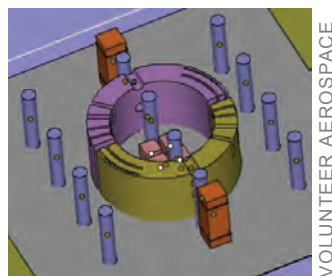

FIGURE 2. Specimen build layout.

Specimen design files were provided by MSFC, which included nondestructive evaluation (NDE) parts with known flaws, metallographic cubes, and standardized tensile bars. VAI printed all components on four different builds, each one purposefully paused for increased amounts of time in order to accurately represent potential build-interruption behavior and measure the impact on temperature change and oxygen exposure, which are known to cause witness marks. Metallographic specimens were prepared and imaged by MSFC and VAI to determine the extent that witness marks have on the microstructure. NDE bars were evaluated with computed tomography (CT) by MSFC and micro-CT by VAI in attempts to detect the known flaws and help to establish the printer resolution as it correlates to the

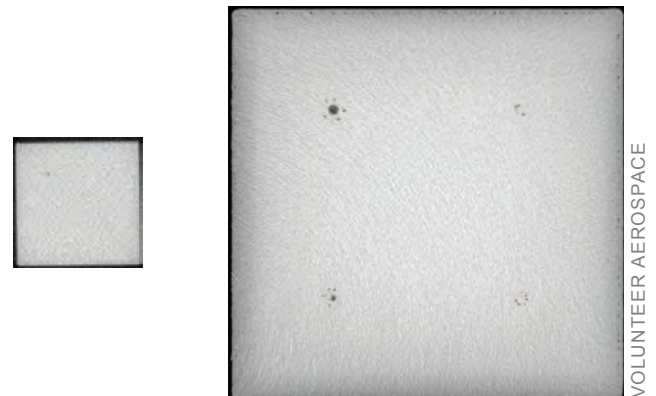

FIGURE 3. CT scan (left) and micro-CT scan (right).

minimal detectability limit of the CT used for inspection. Both MSFC and VAI conducted ASTM E8 tensile testing to determine mechanical properties of specimens built with witness marks in the gauge section. Mechanical testing provides property correlation to the build environment and engineered defects.

CT and micro-CT data show no evidence of witness marks propagating into the parts resulting from build pauses. This result was supported by metallographic inspection that shows no evidence of changes in microstructure in an area of a known witness mark, indicat-

ing that these are indeed a surface feature only. CT data was also used to determine the minimum detectable flaw size. Yield strength, ultimate tensile strength, elongation at fracture, and elastic modulus results are within the expected values for as-built AlSi10Mg, indicating that witness marks in the tensile bar gauge section had no statistically significant impact on performance.

SUMMARY

AlSi10Mg specimens were produced through SLM and paused at various time intervals in order to generate witness marks on the specimens. Metallographic, CT, and mechanical property data show that the witness marks had no statistically significant change on microstructure or mechanical properties. These results will enable a greater degree of flexibility when inspecting SLM components to differentiate between acceptable features of the manufacture process from unacceptable build flaws such as voids and cracks. The ability to accurately assess build potential issues has the potential to improve build-success rate and reduce production costs.

PROJECT MANAGERS AND/OR PRINCIPAL INVESTIGATORS: Omar Mireles

PARTNERSHIP: Volunteer Aerospace Inc.

FUNDING ORGANIZATION: Cooperative Agreement Notice



Fatigue Behavior of Freeform, Additively Manufactured Inconel 718

OBJECTIVE: To evaluate the high cycle fatigue (HCF) life of Inconel 718 blown powder specimens previously fabricated at DMG-Mori by a UAH graduate student intern.

PROJECT DESCRIPTION

NASA has invested significantly in powder bed processes for the additive manufacturing (AM) fabrication of small, complex, monolithic builds. The NASA Marshall Space Flight Center (MSFC) currently has several selective laser melting (SLM) powder bed systems from Laser Concepts. As illustrated in figures 1 and 2, the x-line has the largest build envelope of $630 \times 400 \times 500$ mm as compared to the M2 envelope of $254 \times 254 \times 280$ mm. While SLM has successfully demonstrated the ability to build liquid rocket engine (LRE) injectors and small thrust chambers, larger components cannot be built as one piece in the limited dimensional space. As a result, other AM technologies are required to directly print larger components to support the reduced cost fabrication of RS-25 and RL-10 engines. Blown powder AM processes may provide a complimentary technique to the SLM powder bed system with its ability to free form build large structures and also bimetallic components. The primary goal of the proposed study will be to evaluate the mechanical properties including high cycle fatigue (HCF) for Inconel 718 blown powder specimens. The evaluation will include documentation of the microstructure and its effect on mechanical properties.

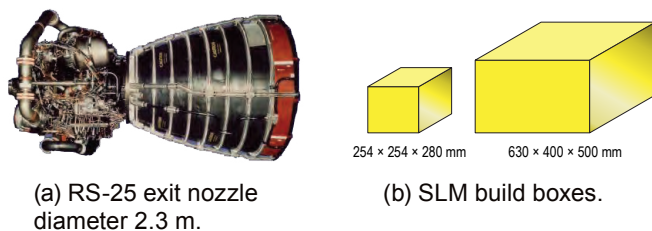

FIGURE 1. Overview of the relative size of the RS-25 engine (a) compared to the build envelope of SLM process (b).

ACCOMPLISHMENTS

Due to the range of sizes and materials involved in the fabrication of an LRE, such as RS-25, it is imperative that the NASA engineers understand the processes available and their resulting material properties and limitations. Use of blown powder for direct metal deposition (DMD) complements the use of SLM powder bed

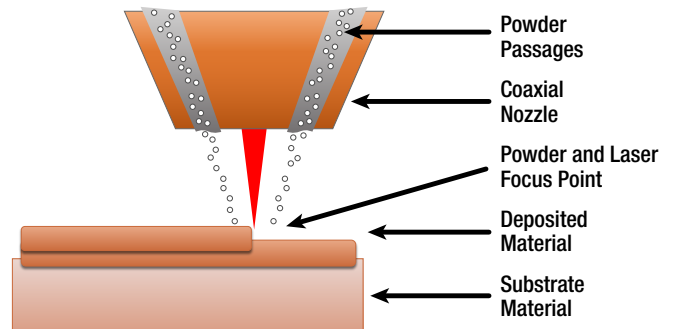

FIGURE 2. Overview of the blown powder system.

systems. The blown-powder DMD process uses larger (100 mm versus 45 mm) diameter powders fed through a nozzle and melted by a directed laser.

The DMD processes provide the ability to freeform a build outside of the limitations of a powder bed box. While there are various blown powder systems available, the resulting surface finish is not as fine as that achieved in SLM processing. Therefore, building off a computer numeric control (CNC) platform, DMD processes are providing the opportunity to incorporate both additive and subtractive manufacturing capabilities into one machine. This provides the ability to both additively build a structure and ensure that required surface finishes and dimensional tolerances are maintained as the part is built. This project teamed with DMG-Mori, a world leader in the production of additive/subtractive processes. A University of Alabama in Huntsville (UAH) student interned at DMG-Mori to produce specimens of Inconel 718 which were then

Blown Powder		UTS (MPa)	Elongation (%)	Yield (MPa)
With HIP	No Argon	1169.7 + 13.6	12.3 + 0.26	952.3 + 24.9
	Argon	1264.0 + 24.9	13.0 + 1.87	1092.1 + 33.1
Non HIP	No Argon	1139.7 + 44.4	6.8 + 3.21	1003.4 + 34.3
	Argon	1185.7 + 29.8	5.9 + 0.78	1043.2 + 34.8
SLM with HIP		1395.7 + 4.2	23.6 + 0.36	1110.9 + 7.4

TABLE 1. Tensile properties of the blown powder systems.

		Stress Level at R = 0.1		
		690 MPa	552 MPa	276 MPa
With HIP	No Argon	1.52E+05	1.86E+06	1.00E+07*
	Argon	1.01E+05	2.23E+06	1.00E+07*
Non HIP	No Argon	1.25E+05	1.24E+05	5.09E+06
	Argon	1.88E+04	1.32E+05	3.95E+05

TABLE 2. HCF data for the blown powder specimens.

machined into tensile and fatigue specimens for evaluation of their mechanical properties in addition to microstructural characterization.

Tensile data is summarized in table 1 as compared with SLM data. The HCF data is summarized in table 2. Specimens which were not subjected to a hot isostatic press (HIP) cycle show lower elongation to failure and also fatigue life.

SUMMARY

Detailed metallurgical analysis showed similar void size between the as-built, HIP, nonHIP, and SLM specimens. Tensile data is slightly lower than the SLM data, which is related to the larger powder size used. HCF data shows improvement with HIP processing and is similar to SLM HIP properties. Based on preliminary data obtained under this grant, blown powder process-

ing is a viable process for AM of large components which are outside the processing envelope size of SLM powder bed. Figure 2 is a diagram of the blown powder system.

PROJECT MANAGERS AND/OR PRINCIPAL INVESTIGATORS: Brian West, NASA MSFC and Judy Schneider, UAH

PARTNERSHIP: Specimens were produced at DMG-Mori

FUNDING ORGANIZATION: Cooperative Agreement Notice

Low Cost Upper Stage-Class Propulsion (LCUSP)

OBJECTIVE: To develop high-pressure/high-temperature combustion chambers and nozzles with copper and nickel alloys using additive manufacturing.

PROJECT DESCRIPTION

Low Cost Upper Stage-Class Propulsion (LCUSP) is developing the process of using selective laser melting (SLM) of copper-alloy GRCop-84 and electron-beam freeform fabrication (EBF3) with nickel-alloy Inconel 625 to produce a regen-cooled rocket combustion chamber. By utilizing SLM and EBF3 additive manufacturing techniques, manufacturing cost and schedule are greatly reduced. Performing a hot-fire test in a relevant environment demonstrates the performance and compatibility of a GRCop-84 chamber liner with an EBF3 Inconel 625 chamber jacket.



FIGURE 1. Combustion chamber showing the bimetallic bond of GRCop-84 liner and the Inconel 625 structure jacket and manifolds.

The LCUSP program was designed to develop processes and material characterization for the GRCop-84 copper-alloy commensurate with powder bed additive manufacturing, evaluate bimetallic deposition of Inconel 625 onto GRCop-84, and complete testing of a full-scale combustion chamber.

Thrust chamber assemblies must withstand both extremely high-heat loads and high pressures as they generate thrust from chemical energy. The LCUSP project focused on advancing two manufacturing processes to improve fabrication: (1) SLM of GRCop-84 and (2) bimetallic bonding of GRCop-84 and Inconel 625 using EBF3. SLM sinters layers of fine GRCop-84 powder to form the copper-alloy liner. The liner has complex integral coolant passages to properly cool the walls and address the high heat loads the chamber experiences during operation. GRCop-84, a material developed at NASA Glenn Research Center (GRC)—located in Cleveland, Ohio—provides excellent heat conduction and high strength at elevated temperatures. EBF3, under development by the Langley Research Center (LaRC), was used to additively manufacture a nickel-alloy structural support jacket to the GRCop-84 liner that provides structural support to the chamber during operation. In addition, materials scientists from GRC performed extensive analysis and materials characterization of the rocket part. These technologies allow engineers to tailor designs and include custom geometries that were costly or impossible to realize in parts before this technology was developed.



FIGURE 2. A hot-fire test of Unit 3 occurred on November 9, 2017. The chamber pressure reached 900 psi and produced 17,000 lbf of thrust.

ACCOMPLISHMENTS

Last year, the LCUSP team partnered with the Landers Technology Team in the first ever hot-fire of a SLM copper-alloy chamber. The methane fuel was used as a coolant fluid through integrally printed coolant passages to cool the high-heat flux throat region. The hardware performed excellently, producing the design goal of 4,000 lbf of thrust and demonstrating the viability of utilizing components manufactured with additively manufactured copper-alloys in relevant environments and setting the stage for the hot-fire test of the full-scale thrust chamber unit 3.

Unit 3 was successfully hot-fire tested on November 9, 2017, at Marshall Space Flight Center. This marks a technology first for a successful hot-fire test of a liquid oxygen/liquid hydrogen regen-cooled, GRCop-84 copper-alloy, 3D-printed combustion chamber with an integral EBF3-deposited, nickel-alloy structural jacket. Unit 3's chamber pressure reached 900 psi at a mixture ratio of 4.8. The inlet coolant channel pressure reached 2,100 psi. Over 17,000 lbf of thrust was produced during the test. Performances, pressures and flows were as predicted. Further analysis and testing will provide additional information to advance the process.

SUMMARY

While LCUSP has focused on thrust chamber components, the capabilities to additively manufacture with copper-alloys and perform bimetallic deposition is applicable to a variety of applications. Processes and parameters are available to industry partners to enable a long-term supply chain of copper combustion chambers. LCUSP is part of a strong base of novel manufacturing techniques upon which the Rapid Analysis and Manufacturing of Propulsion Technologies (RAMPT) project can build and further evolve the advanced manufacturing work performed by NASA. The RAMPT project will develop and advance large-scale, lightweight, multimetallic freeform manufacturing and composite overwrap techniques and analysis capabilities required to implement them to reduce design and fabrication cycles for regen-cooled liquid rocket engine components.

PROJECT MANAGER AND/OR PRINCIPAL

INVESTIGATOR: John Fikes

PARTNERSHIPS: NASA LaRC and GRC

FUNDING ORGANIZATION: Game Changing Development

The Fabrication of Lightweight, Full-Shell, Replicated Optics by Additive Manufacturing

OBJECTIVE: To replace a portion of the thickness of traditional nickel cobalt (NiCo) electroformed optics with a lightweight printed ceramic.

PROJECT DESCRIPTION

This proposal enables, for the first time, a method of fabricating lightweight x-ray optics. The innovation offers the potential to significantly reduce the number of optics, cost, and complexity associated with the development of the next generation of large-area, high-resolution x-ray space telescopes. The ultimate aim of the proposal is to fabricate a segment or full-shell hybrid-ceramic replicate with a demonstrated angular resolution on the order of 30 arc s.

There are several parallel technological approaches which all leverage the Marshall Space Flight Center's (MSFC's) expertise in mandrel fabrication, metrology, and electroforming. The new technological element presented here is related to the use of additive manufacturing (AM), which is utilized to provide a lighter-weight alternative to electroforming, but while also offering the potential to fabricate high-resolution optics without the need for secondary processes currently needed to improve the optic's imaging resolution. This approach also potentially enables the integration of mounting and alignment mechanisms onto the optic during the printing process. The first approach is a hybrid method that utilizes nickel cobalt (NiCo) replicated optics which are traditionally electroformed then released from a precisely formed mandrel. The electroforming process produces replicates with the required smooth surface quality needed to achieve good specular reflectivity at x-ray wavelengths. The replicate, however, must be thick enough to provide the necessary flexural strength to the optic to preserve its figure, but this adds weight

and limits the collecting area of the optical assembly for a given mass budget. Our approach is to replace a significant portion of the NiCo thickness with a much less dense (nearly a factor of three) printed ceramic material. In this way, the lighter-weight ceramic composing the bulk of the optic provides the necessary flexural strength, while the thin layer of electroformed NiCo provides the smooth optical x-ray reflective surface. This concept is illustrated in figure 1. An alternative approach utilizes flexible ultrathin substrates (i.e., 25 μm) composed of glass or crystalline silicon which is bonded to the ceramic optic after the printing process. This may be required because the ceramic must be heat treated after printing in order to optimize its mechanical properties. This results in shrinkage of the optic with respect to the electroformed nickel and may cause low-frequency figure errors in the optic. The use of ultrathin substrates potentially eliminates this problem because it is bonded to the optic after heat treatment. This method may provide an additional advantage because the optical thin-film coatings used to enhance x-ray reflectivity are easier to deposit on flat substrates in comparison to the curved surface of a formed optic. Additionally, the necessary surface finish is easier to achieve on flat substrates in comparison to other methods which require polishing of curved surfaces.

The second year will be used to further investigate the feasibility of both of these approaches. After evaluation and down selection of the method, we intend to replicate a partial optical segment and evaluate the ensuing angular resolution.

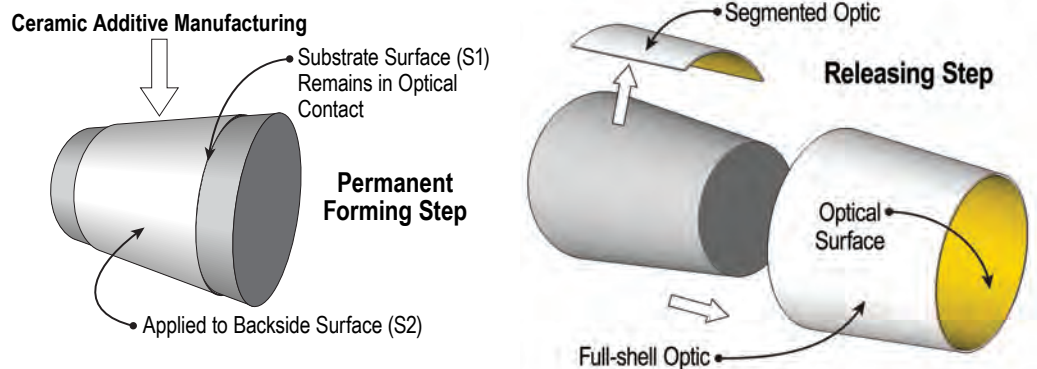

FIGURE 1. Hybrid replicated optics approach.

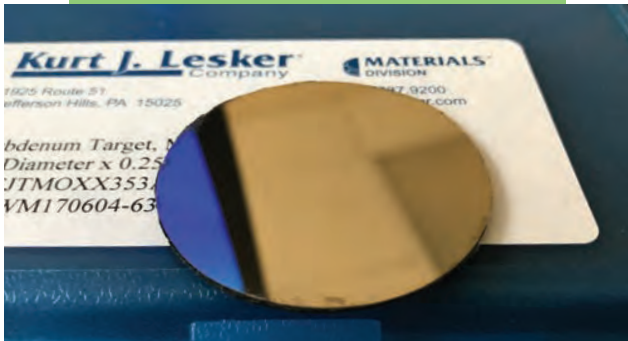
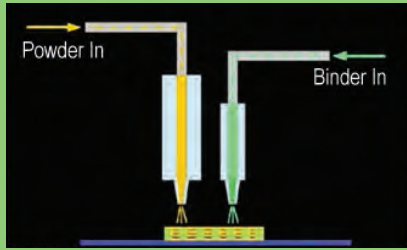
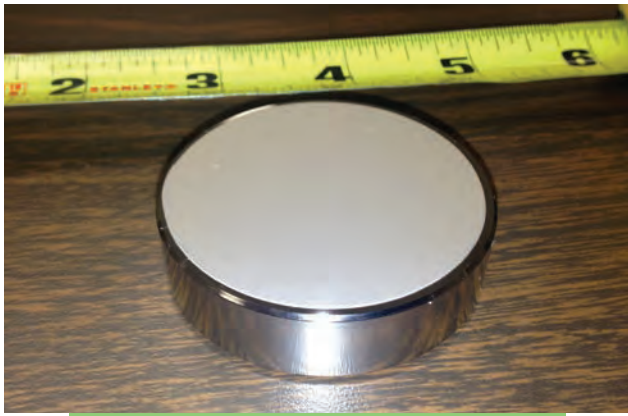

FIGURE 2. The first hybrid ceramic optic was produced on a 2-in-diameter flat. The low-frequency figure of the sample appeared to be negatively influenced by the shrinkage mismatch between the ceramic and electroformed NiCo, however.

ACCOMPLISHMENTS

In the first year, we were able to demonstrate the principle of the electroformed/ceramic hybrid on a flat mandrel, figure 2. The process involved the electroforming of a 50- μm -thick layer of electroformed NiCo on a 2-in-diameter polished flat. Afterward, a 1-mm-thick boron carbide layer was printed on the back surface of the NiCo replicate and heat treated at 150 °C while still in contact with the mandrel. Afterward, the hybrid was released from the master and the quality of the optical surface evaluated. We found that the high-frequency surface roughness of the replicate ($\approx 10 \text{ \AA}$) was preserved after the ceramic printing process (i.e., no ‘print through’). However, the low-frequency error (i.e., waviness) of the sample was not as promising. Further work is needed to characterize this effect as being attributed to shrinkage mismatch between the ceramic and electroformed NiCo. The use of an ultrathin, flexible substrate that is bonded to the printed ceramic may obviate this problem and potentially eliminate the electroforming process step.

SUMMARY

In the first year of funding, we have demonstrated the proposed hybrid-replication process for a flat, 2-in-diameter sample. The good surface quality at high spatial frequencies is preserved after the replication process. We have found, however, that shrinkage mismatch between the ceramic and electroformed NiCo may occur during the heat treatment of the printed ceramic and contribute to the low frequency figure thus far observed. An alternate approach to mitigating this problem has been proposed, which relies on the use of ultrathin substrates. The substrates are flexible and can be formed and bonded to the ceramic after heat treatment. The use of flexible substrates offers an additional advantage, since the coating applied to enhance x-ray reflectivity is easier to deposit on flat substrates. We have received additional funding for a second year to continue the development of this work.

PROJECT MANAGER AND/OR PRINCIPAL

INVESTIGATOR: David Broadway

PARTNERSHIP: Hot End Works (Industrial Partner)

FUNDING ORGANIZATION: Center Innovation Fund

Composite Technology for Exploration (CTE)

OBJECTIVE: To advance composite technologies with a focus on weight-saving, performance-enhancing bonded-joint innovations for heavy-lift launch-vehicle-scale applications to support future NASA exploration missions.

PROJECT DESCRIPTION

The Composite Technology for Exploration (CTE) project is developing and demonstrating critical composite technologies for future NASA exploration missions with a focus on composite joint technologies for heavy-lift launch-vehicle-scale hardware. Composite joints can account for significant increases in cost and weight. Through materials characterization studies; advanced analysis tools; and the design, manufacturing, and testing of lightweight composite bonded-joint concepts, CTE is producing weight-saving, performance-enhancing composite bonded-joint technologies. CTE is developing and validating high-fidelity analysis tools and standards for predicting failure and residual strength of composite bonded joints. By applying this comprehensive approach, composite technology will progress and

lower part count, and reduced life-cycle cost. NASA plans to advance composite technologies that provide lightweight structures to support future exploration missions. Due to the large 8.4-m diameter of a heavy-lift-type launch vehicle and the unavailability of large autoclaves for curing composite structures, individual large composite panels must be manufactured separately and then joined together. The state-of-the-art method for joining launch vehicle composite panels and structures is using metallic joints that are both heavy and labor intensive. Through CTE, NASA is gaining experience on developing lightweight composite joints and analysis techniques specifically applicable to large-scale composite structures.

CTE has designed a bonded (no fasteners) longitudinal joint. Joint test coupons will be fabricated and tested. Large-scale longitudinal joint tests will follow. A much

bigger challenge with a much larger payoff includes designing and testing a bonded circumferential joint. CTE has down-selected several analytical programs and failure theories. The project is currently analyzing joint designs with selected programs and theories. Results of the different joint tests which include testing to failure in flight-like conditions will be used to evaluate analytical approaches. When complete, a tailored approach for the reduction of factors of safety for composite discontinuities and for highly accurate failure prediction capabilities will be published.

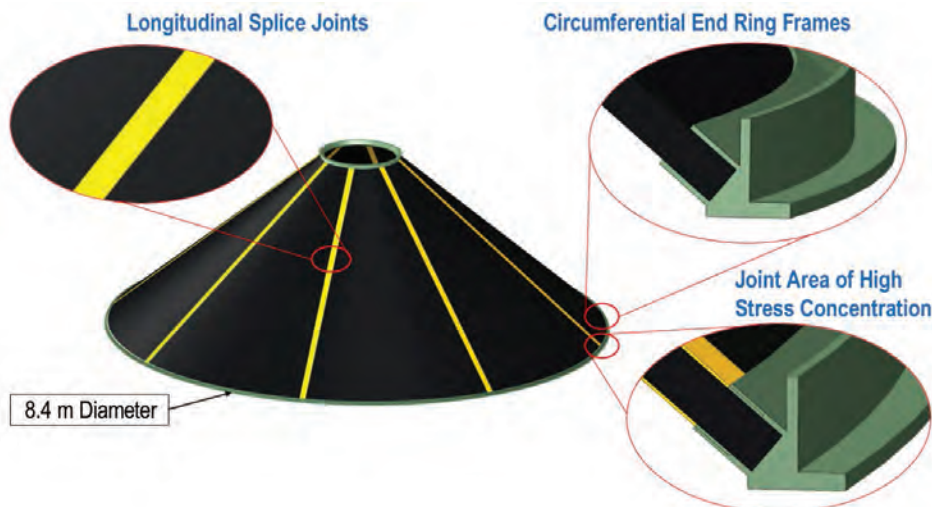

FIGURE 1. A conical structure point design was selected for the most widely applicable and challenging joint geometries and loads.

improve bonded-joint failure load and mode predictions to help reduce knockdown factors and increase overall confidence in bonded-joint composite structures.

When properly designed, composite structures have many potential benefits over traditional metallic structures, including lower mass, better fatigue resistance,

ACCOMPLISHMENTS

In the first year of CTE, a carbon fiber/epoxy prepreg material from a previous NASA project, which had exceeded its vendor-recommended freezer life, was recertified through a user-defined set of chemical and

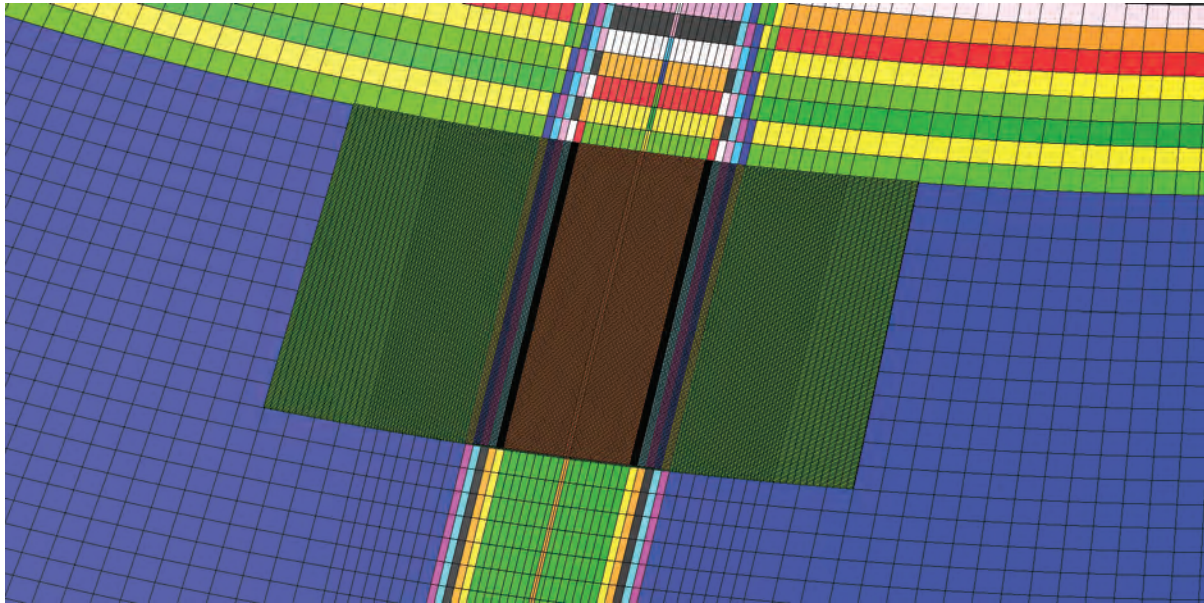

FIGURE 2. Finite element modeling provided detailed analysis and sizing for the final longitudinal composite bonded joint design.

mechanical tests. A material equivalency test matrix was established, and test coupons were fabricated at Marshall Space Flight Center and Langley Research Center (LaRC) to demonstrate equivalency to the existing National Center for Advanced Materials Performance (NCAMP) database. Room-temperature dry properties show equivalency, and elevated-temperature wet tests are complete.

In support of the longitudinal joint design, out of autoclave joint material test coupons have been fabricated and tested for use in joint analyses. Additional test coupons comprised of base material, joint material, and film adhesive will be characterized for use in failure analyses.

SUMMARY

The potential benefits of CTE's composite joints technology development activities include weight savings, cost savings, and improved performance with increased reliability compared to metallic structures/joints. The project will enable the technology infusion of lightweight composite joints into future exploration missions. CTE is working to achieve these potential benefits by developing and validating high-fidelity analytical tools and standards for predicting failure and the residual strength of composite bonded joints. This allows for a tailored approach to reducing the safety factor for composite discontinuities while still reducing risks and increasing confidence in composite-joint technologies.

PROJECT MANAGER AND/OR PRINCIPAL INVESTIGATOR: John Fikes

PARTNERSHIPS: Game Changing Development Program, SLS Spacecraft and Payload Integration/Evolution (SPIE) Office, LaRC, Goddard Space Flight Center, Glenn Research Center

FUNDING ORGANIZATION: Game Changing Development

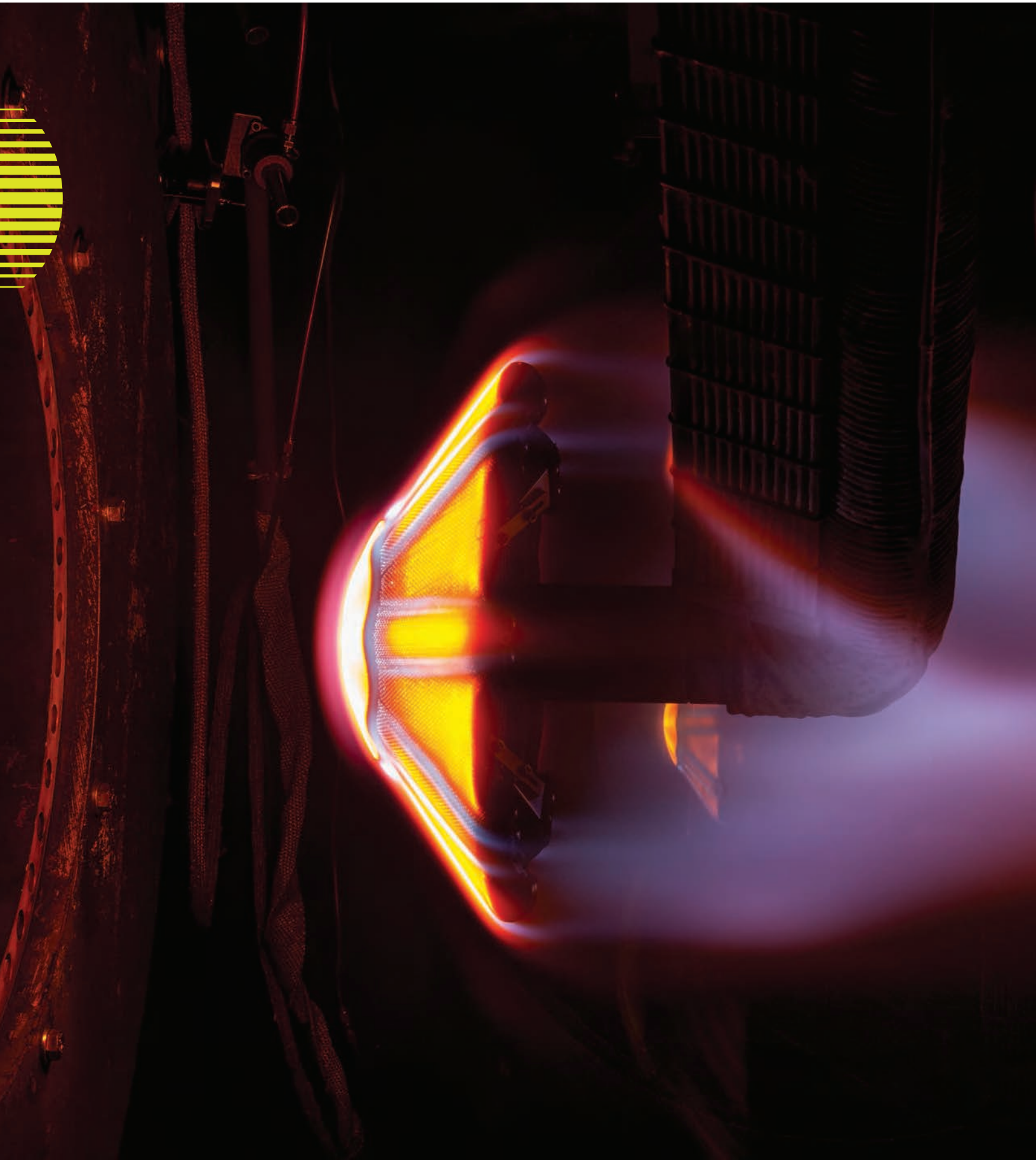



THERMAL MANAGEMENT

Thermal management systems acquire, transport, and reject heat, as well as insulate and control the flow of heat to maintain temperatures within the specified limits. Virtually all spacecraft and related equipment require some level of thermal control, some much more tightly controlled than others, and the design approach and technologies employed vary widely depending on application. Thermal control is critical to maintaining life support environments for the crew inside the vehicle, to preserving cryogenic temperatures for certain

propellants, and to ensuring structural integrity during launch. Therefore, the most fundamental goal of a thermal management system is to maintain temperatures of a sensor, component, instrument, spacecraft, or space facility within the required temperature limits, regardless of the external environment or the thermal loads imposed from operations. The technologies detailed in this section focus on cryogenic thermal control, in keeping with Marshall Space Flight Center's expertise in propulsion systems.

An Adaptive Time-Stepping Approach for Transient Simulations with GFSSP

OBJECTIVE: To develop an adaptive time-stepping technique for the Generalized Fluid System Simulation Program (GFSSP) to substantially reduce computational time for simulating fluid and thermal transient in a liquid propulsion system.

PROJECT DESCRIPTION

The Generalized Fluid System Simulation Program (GFSSP) is a general-purpose flow-network analysis software routinely used for propulsion system analysis across the Agency. A flow system is discretized into a finite number of connected control volumes where mass, momentum, and energy conservation equations are solved implicitly for a transient simulation using a fixed time step. The computational time is strongly dependent on time step, which is usually chosen from analysts' experience or trial-and-error process. The time step used is typically conservative, and transient simulation of a large network takes a long time to run. There is a need to enhance GFSSP's computational efficiency to enable simulation of long-duration space missions involving cryogenic fluid management. The current project is an attempt to develop an adaptive time stepping capability, where time step will be estimated from the feedback of a control theory to eliminate the unnecessary conservatism in selecting time step.

Approach/Innovation

The proposed activity was to develop an adaptive time step algorithm based on proportional integral derivative (PID) control theory suitable for long transient simulations of cryogenic heat transfer problems and to integrate the algorithm into NASA Marshall Space Flight Center's (MSFC's) GFSSP. These algorithms and tools were integrated into GFSSP software and validated by simulating problems critical to improving cryogenic storage and transport. The proposed adaptive time stepping strategy for network flow models combines change of the solution in two subsequent time steps and PID feedback control theory. It utilizes normalized changes in key variables such as flow rate, pressure, and temperature to compute the local errors e_n . The control is constructed such that it reduces the time step if the solution change is relatively large and increases it if the change is small. If the error is larger than a given toler-

ance, this error signal will be sent to the PID controller, and the controller computes both the derivative and the integral of this error signal. The time step Δt to the flow solver is equal to the proportional gain (K_p), times the magnitude of the error, plus the integral gain (K_i), times the integral of the error plus the derivative gain, (K_d) times the derivative of the error.

ACCOMPLISHMENTS

In this problem, we evaluate the adaptive approach in prediction of chilldown of cryogenic transfer line in which a long, vacuum-jacketed copper pipe (200-ft-long and 0.625-in-diameter) is attached to a storage dewar containing liquid hydrogen (LH_2); the other end is open to the atmosphere. The liquid hydrogen inside the tank could be saturated or subcooled. At times zero, a valve upstream of the pipe begins to open, and liquid hydrogen (LH_2) begins to flow into the feedline due to tank pressure. The simulations, reported below, used liquid

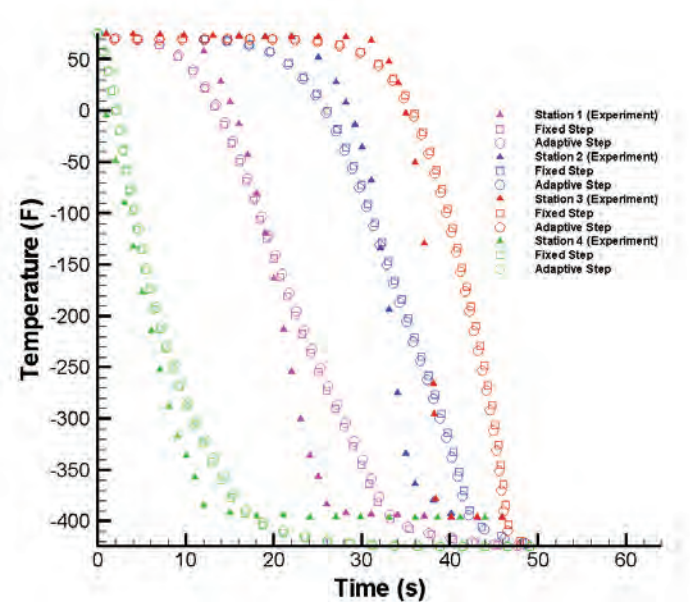

FIGURE 1. Transient temperature for the subcooled LH₂ for the driving pressure 111.69 psia at four stations.



hydrogen supplied from the tank at 111.69 psia and at -424.57 °F and exiting to the atmosphere at 12.05 psia.

The computations were performed with constant time step $\Delta t = 0.001$ s. The predicted temperature history is shown in figure 1. Stations 1–4 are nodes whose locations correspond to four measurement locations in the experimental data. These stations are located at 20, 80, 140, and 200 ft, respectively, downstream of the tank.

These numerical predictions compare well to the measured temperatures. At this driving pressure, the pipeline chills down in about 46 s. The adaptive time-stepping algorithm is tested with this problem by using an initial time step of $\Delta t = 0.001$ s. The time step is adjusted between $\Delta t_{\min} = 0.001$ s and $\Delta t_{\max} = 0.007$ s. In this problem, the adaptive scheme provides about 65% decrease in central processing unit (CPU) time for all the grid sizes considered. This proves that the time adaptive technique we have presented is an effective tool to obtain accurate and economical prediction of fluid and thermal transient of a liquid propulsion system.

SUMMARY

An adaptive, unstructured, finite-volume approach for efficient prediction of fluid and thermal transient in fluid network was developed. The ability to efficiently predict the coupled interactions in feedline was demonstrated by numerically solving first an air-water, two-phase problem of entrapped air in the water pipe and then solving a vapor-liquid two-phase problem of chilldown of cryogenic feedline. Numerical predictions with the adaptive strategy were compared with experimental data and found to be in good agreement. The strategy was found to be efficient for predicting fluid and thermal transient in flow network at reduced CPU time, compared to traditional flow network solvers. Moreover, it was shown that the adaptive approach improves the convergence behavior of the nonlinear solvers leading to further reduction in CPU time. In the cases of entrapped air in water pipe and chilldown of cryogenic feed line, the CPU time was decreased about 90% and 68%, respectively, without significant differences in the result.

PROJECT MANAGER AND/OR PRINCIPAL

INVESTIGATOR: Alok K Majumdar, Marshall Space Flight Center (MSFC) and S.S. Ravindran, University of Alabama in Huntsville (UAH)

PARTNERSHIP: UAH

FUNDING ORGANIZATION: Cooperative Agreement Notice

FOR MORE INFORMATION: <https://gfssp.msfc.nasa.gov/>

Evolvable Cryogenics (eCryo) Project

OBJECTIVE: The Evolvable Cryogenics (eCryo) project is a joint effort between Glenn Research Center (GRC) (Lead) and Marshall Space Flight Center (MSFC) to create and manage a portfolio of efforts that aim to increase the technology of storage and use of cryogenic fluids (mainly propellants) for space exploration.

PROJECT DESCRIPTION

The Evolvable Cryogenics (eCryo) project has had several projects under its management over FY2017—a 4-m cryogenic tank (fig. 1), the Integrated Vehicle Fluids (IVF) test to evaluate a United Launch Alliance (ULA) concept for Space Launch System (SLS), computer thermal modeling of propellants (fluids) and low-leakage cryogenic valves. These elements comprise the majority of the projects that are shared by Glenn Research Center (GRC) and Marshall Space Flight Center (MSFC) under the eCryo project aegis. The large cryogenic tank (right) is at MSFC for a spray-on-foam-insulation (SOFI) coating and will then be delivered to Plumbrook Facility (near GRC) for cryogenic testing of insulation after exposure to acoustic launch environments.

ACCOMPLISHMENTS

Up to this point, the need to keep cryogenic propellants conditioned has only been 8–12 hr from loading to use (in general). This has been sufficient for low earth orbit (International Space System (ISS) and Shuttle) and journeys to the moon (Apollo). As the push to move deeper into space grows ever stronger, the need to keep propellants usable for longer and longer periods becomes more mission critical and more difficult. The eCryo project has created a roadmap of cryogenic technologies that have been deemed essential to improving the capabilities to store and transfer cryogenic propellants. The eventual goal is a state called ‘zero boiloff.’ The eCryo project office continues to look for ways to improve the technology readiness level of these nearly 30 different technologies.

The testing of the IVF concept was one of the larger efforts for eCryo in FY2017. The eCryo team has been assessing the IVF concept for over 2 years. The final report was delivered to SLS in July of FY2017. The assessment has been a combination of computer modeling, hardware simulation, and testing of actual hardware. In figure 2, an uninsulated large valve is shown during liquid nitrogen (LN₂) testing. The purpose of IVF is to combine several fluid systems into one with a lower mass and other benefits. The testing at MSFC Test Stand 300 shows that the IVF concept works using real hardware. The computer model (right) shows what happens when a hot jet of gas is injected into a cryo-

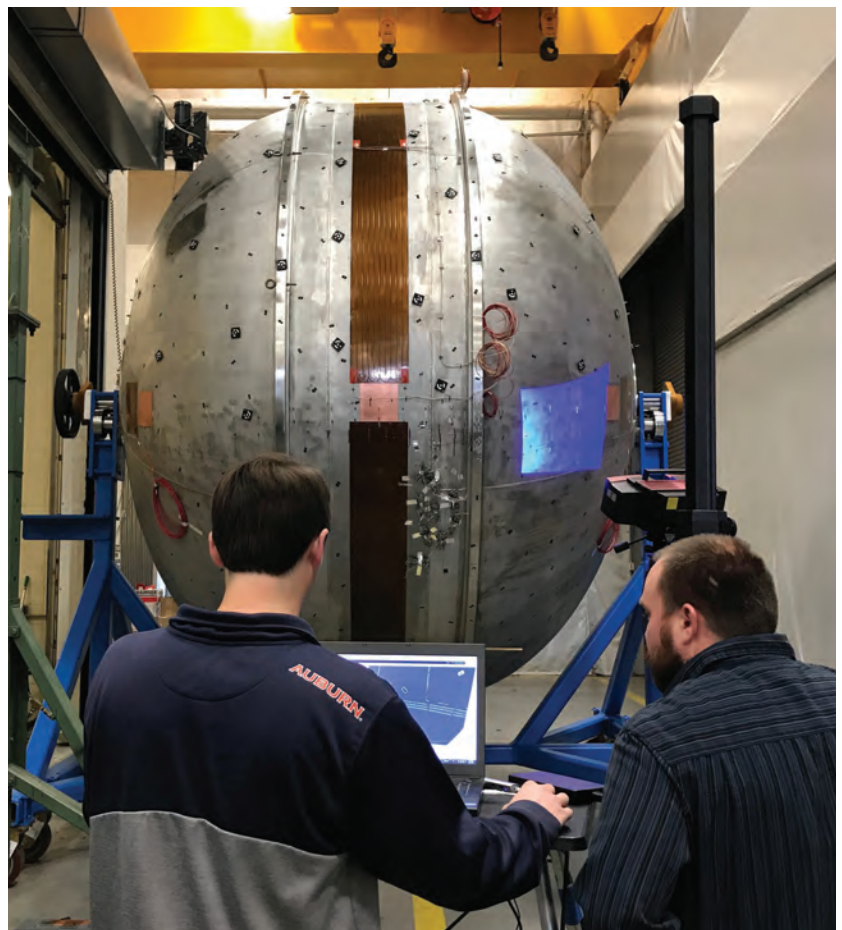

FIGURE 1. 4-m cryogenic tank being tested for dimension.

FIGURE 2. A facility cryogenic vent in use during IVF testing.



genic tank in low gravity conditions. The fluid surface is significantly disturbed. This is a condition to be avoided. There is still significant development work yet to be done by ULA before the system is flight worthy. The 4-m tank in figure 1 is the other significant piece of work that eCryo has achieved over FY2017. The tank was designed with the assistance of MSFC engineering. The tank was constructed by a contractor and then delivered to MSFC for instrumentation and SOFI application.

SUMMARY

The eCryo project continues to be a successful and necessary joint effort between Glenn Research Center and Marshall Space Flight Center. The need to keep, maintain, and transfer cryogenic propellants is only going to increase as NASA and NASA partners continue to push the physical boundaries of exploration further out from low earth orbit. Regardless of the type of propulsion system—liquid oxygen/liquid hydrogen, liquid oxygen/methane, nuclear thermal propulsion—the need to keep cryogenic propellants in liquid form is a mission-critical technology that needs to continue the path to maturity.

PROJECT MANAGERS: Hans Hansen, GRC and Arthur Werkheiser, MSFC

PARTNERSHIPS: ULA, Roush Engineering

FUNDING ORGANIZATION: Technology Demonstration Missions

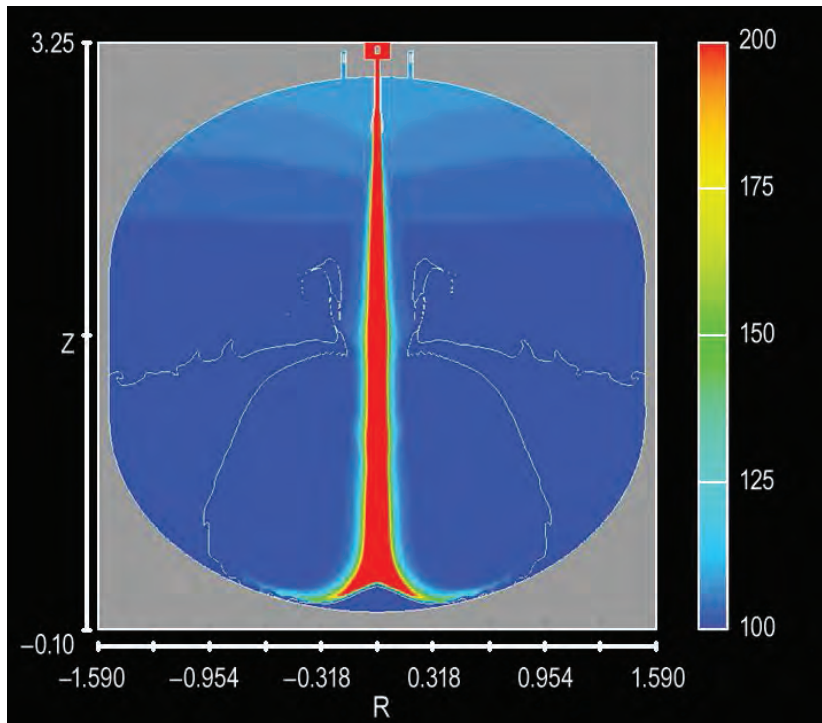

FIGURE 3. A computer model of a jet into a tank of liquid.

Centennial Challenges

OBJECTIVE: To stimulate innovation in basic and applied research, technology development, and prototype demonstration that has the potential for application to the performance of the space and aeronautical activities of the Administration.

PROJECT DESCRIPTION

NASA's Centennial Challenges Program began in 2005 to directly engage the public in the process of advanced technology development. Incentive prizes generate revolutionary solutions to problems of interest to NASA and the Nation. The program seeks innovations from diverse and nontraditional sources, including independent inventors, small businesses, student groups, and individuals.



FIGURE 1. Left to right are Steve Jurczyk, HQ; Second Place, CU-E3; First Place, Cislunar Explorers; Third Place, Team Miles; and Eugene Tu, Ames Center Director.



FIGURE 2. Kevin Knoedler of team Coordinated Robotics wins first prize in NASA's Space Robotics Challenge.

This stimulates opportunities for creating new industries and new business ventures. Competitors are not supported by government funding, and awards are only made to teams when the challenges are met.

Challenges address current topics on NASA's technology road map that are also beneficial to other technology

sectors here on Earth. Teams have a unique opportunity to leverage their ideas, whether they win prize money or not. Through the visibility of the challenges, all participants gain the opportunity to be seen by and network with industries that may be searching for similar solutions, as well as each other, media outlets, and the public at outreach events.

The program works with allied organizations (typically, a nonprofit), sponsors, and other NASA Centers to put on unique challenges. The competitors come from a wide variety of backgrounds and expertise, which broadens the solutions for technology needs. These competitions are typically designed to be completed within a year or 2. Some Challenges have more than one phase, allowing for different barriers of a specific technology need to be addressed or to allow each phase to build upon the previous phases. Competitor teams have been known to compete in multiple phases and Challenges.

ACCOMPLISHMENTS

Centennial Challenges had four open Challenges with six competition events in FY2017 and awarded prize money in each of the competitions, a total of \$1,466,024. This represents the highest percentage of available prize money (62%) ever awarded. The program also began the formulation of five new challenges in FY2017.

3D-Printed Habitat Challenge, in partnership with Bradley University, is advancing the additive construction technology needed to create sustainable housing solutions for Earth and deep space exploration. The competition is divided into three phases focused on design, materials and fabrication. This Challenge has seen the successful completion of phases 1 and 2. Phase 2 Structural Member Competition focused on manufacturing structural components and was completed in August 2017. Money was awarded to teams for all three levels of phase 2. Prizes awarded were as follows: Level 1, \$100,000, two teams; level 2, \$201,024, six teams; level 3: \$400,000, two teams. Phase 3 of the competition opened in November 2017.

Cube Quest Competition gave teams the objective of designing, building, and delivering flight-qualified small satellites capable of advanced operations near and beyond the moon. This competition awarded the top 5 teams, in October 2016, a total of \$150,000 (\$30,000 each). The fourth and final Ground Tournament of the Cube Quest Challenge was conducted in June 2016. The top three teams won a total of \$60,000 (\$20,000 each) and a secondary payload slot for their CubeSat on the Space Launch System Exploration Mission-1 flight.

Space Robotics Challenge, in partnership with Space Center Houston, invited teams to develop autonomous perception and manipulation algorithms and software for the Robonaut-5 humanoid robot utilizing a software simulator. Space Robotics had a very successful Final Virtual Competition, with the top three winning teams getting the chance to put their code in the Robonaut 5. A total of \$255,000 was awarded to the top 20 teams in a qualifying round (February), and a total of \$300,000 to three winning teams in the final Virtual Competition (June). This competition received the program’s largest team response to date, with 405 pre-registrations from 55 countries.

Vascular Tissue Challenge, in partnership with the nonprofit Methuselah Foundation’s New Organ Alliance, offers a \$500,000 prize to be divided among the first three teams that successfully create thick, metabolically-functional human vascularized organ tissue in a controlled laboratory environment. This competition is ongoing, with nine teams currently registered.

SUMMARY

Centennial Challenges had a very successful year, with a large number of domestic and international teams competing in our four open Challenges. The technology advancement, as well as public inspiration in space technology, exceeded expectations. The program will be continuing work on the 3D-Printed Habitat, Cube Quest, and Vascular Tissue Challenges in the next year. Along with those, several new competitions will be in formulation and possibly opening for competition.

PROJECT MANAGERS: Monsi Roman, NASA, Program Manager, and Tony Kim, NASA, Deputy Program Manager

PARTNERSHIPS: 3D Printed Habitat – Bradley University, Caterpillar; Cube Quest – NASA Ames Research Center; Space Robotics, Space Center Houston, NineSigma, NASA Johnson Space Center; Vascular Tissue, Methuselah Foundation’s New Organ Alliance

FUNDING ORGANIZATIONS: Centennial Challenges Program

FOR MORE INFORMATION: www.nasa.gov/winit



INDEX BY FUNDING SOURCES

ADVANCED EXPLORATION SYSTEMS

- Cloud-Based App Design (AVAIL), 94–95
- In-Space Manufacturing (ISM) Multimaterial Fabrication Laboratory (FabLab), 104–105
- In-Space Recycling and Reuse: Refabricator and Erasmus Technologies, 102–103
- Ionic Liquids (ILs) Enabling Revolutionary Closed-Loop Life Support, 44–45
- Near Earth Asteroid Scout, 8–9
- Series-Bosch Oxygen Recovery Mix and Match Evaluations, 46–47

CENTENNIAL CHALLENGES PROGRAM

- Centennial Challenges, 134–135

CENTER INNOVATION FUND

- 3D Printed Electroluminescent Light Panels, 108–109
- Development of Floating Slosh Dampers for Propellant Tanks, 6–7
- Fabrication and Characterization of a Grooved-Ring Fuel Element for a Nuclear Thermal Rocket, 14–15
- In Situ Production of Cementitious Material from Martian Resources, 50–51
- Ionic Liquids (ILs) Enabling Revolutionary Closed-Loop Life Support, 44–45
- Ionic Polyimides: New High-Performance Polymers for Additive Manufacturing, 110–111
- Multiscale Nuclear Thermal Propulsion (NTP) Nuclear Fuel Material Simulation, 18–19
- Pulsed Fission-Fusion (PuFF) Target Design and Containment System, 16–17
- Purification of Lunar Cold-Trapped Volatiles, 52–53
- The Fabrication of Lightweight, Full-Shell, Replicated Optics by 3D Printing, 124–125
- Toward In-Space Additive Manufacturing of Thermosets With Embedded Fibers, 106–107

COOPERATIVE AGREEMENT NOTICE

- An Adaptive Time Stepping Approach for Transient Simulations with GFSSP, 130–131
- Characterizing Effects of Potential Build Induced Defects in Selective Laser Melting Components, 118–119
- Dual-Mode Green Propulsion Proof of Concept: Providing Both Innovative Green Propulsion and Micropropulsion for Small Spacecraft, 28–29

- Fatigue Behavior of Freeform, Additively Manufactured Inconel 718, 120–121
- Immersive Decision-Making Environment (IDME) for Mission-Driven Technology Alignment (MDTA), 92–93
- Liquid Oxygen (LOX) Expansion Cycle: A Dual Cooled-Expander Cycle Engine Using Hydrogen and Oxygen, 22–23
- Low-Cost Plasma Micropropulsion Using 3D Printing and Off-the-Shelf Components, 24–25
- Multimode Micropropulsion for Small Spacecraft, 26–27
- Smartphone Video Guidance Sensor-Based Navigation of RINGS Onboard the International Space Station, 32–33
- Snap-IMS: A Snapshot Hyperspectral Imager for Earth Remote Sensing, 80–81

GAME CHANGING DEVELOPMENT

- Additive Construction With Mobile Emplacement (ACME), 56–57
- Composite Technology for Exploration (CTE), 126–127
- Deep Space Engine, 10–11
- In-Space Manufacturing (ISM) Multimaterial Fabrication Laboratory (FabLab), 104–105
- In-Space Recycling and Reuse: Refabricator and Erasmus Technologies, 102–103
- Low Cost Upper Stage-Class Propulsion (LCUSP), 122–123
- Programmable Ultra Lightweight System Adaptable Radio (PULSAR), 38–39

MSFC INNOVATION DAY SHARK TANK

- Additive Manufacturing Cleaning Process Improvement, 116–117
- Void Optimization Laser-Ultrasonic Additive Manufacturing Test Utility System (VOLATUS), 114–115

SCIENCE MISSION DIRECTORATE

- Advanced Microwave Precipitation Radiometer (AMPR), 60–61
- Advanced UVOIR Mirror Technology Development for Very Large Space Telescopes, 82–83
- CLASP2: The Chromospheric Layer Spectropolarimeter, 62–63
- Fermi Gamma-Ray Burst Monitor (GBM), 66–67
- Fly's Eye Geostationary Lightning Mapper Simulator (FEGS), 64–65
- Hinode, 68–69

Hurricane Imaging Radiometer (HIRAD), 70–71
Lightning Imaging Sensor (LIS), 72–73
Lynx X-Ray Observatory Concept Study, 74–75
Objective Estimation of Tropical Cyclone Intensity, 76–77
Predictive Thermal Control Technology for Stable Telescopes, 88
Short-Term Prediction Research and Transition (SPoRT), 96–97
Technology Development of the Mars Ascent Vehicle Hybrid Fuel Grain, 12–13
Testing and Calibration of the Parker Solar Probe Mission SWEAP Solar Probe Cup, 78–79
The Imaging X-Ray Polarimetry Explorer (IXPE), 84–85

SPACE LAUNCH SYSTEM DEVELOPMENT

Advanced Booster: Hydroxyl-Terminated Polyether (HTPE) Propellant Liner Insulation (PLI) System Development, 4–5

TECHNOLOGY DEMONSTRATION MISSIONS

Evolvable Cryogenics Project (eCryo), 132–133

TECHNOLOGY INVESTMENT PROGRAM

Electric Sail Tether Deployment System, 20–21
Embedded Wireless Strain Sensors for Rapid Characterization of Structural Health, 100–101
Habitat Ground-Based Demonstrator: Auto-Operator for the Autonomous Fluid Transfer System (AFTS), 34–35
Ionic Liquid (IL) Metals and Oxygen Extraction in Microgravity: A Prelude to Asteroid Mining, 54–55
Mars Ascent Navigation, 40–41
Next-Generation Lightning Instrument Package (LIP) via Merged Sensor and Data Technologies, 86–87
Space Environmental Effects on Additively Manufactured Parts, 112–113

U.S. AIR FORCE SPACE AND MISSILE SYSTEMS

Integrated Oxygen-Rich Test Article (IOTA), 2–3

REPORT DOCUMENTATION PAGE

Form Approved
OMB No. 0704-0188

The public reporting burden for this collection of information is estimated to average 1 hour per response, including the time for reviewing instructions, searching existing data sources, gathering and maintaining the data needed, and completing and reviewing the collection of information. Send comments regarding this burden estimate or any other aspect of this collection of information, including suggestions for reducing this burden, to Department of Defense, Washington Headquarters Services, Directorate for Information Operation and Reports (0704-0188), 1215 Jefferson Davis Highway, Suite 1204, Arlington, VA 22202-4302. Respondents should be aware that notwithstanding any other provision of law, no person shall be subject to any penalty for failing to comply with a collection of information if it does not display a currently valid OMB control number.

PLEASE DO NOT RETURN YOUR FORM TO THE ABOVE ADDRESS.

1. REPORT DATE (DD-MM-YYYY) 01-07-2018			2. REPORT TYPE Technical Memorandum			3. DATES COVERED (From - To) October 2016–October 2017		
4. TITLE AND SUBTITLE Marshall Space Flight Center Research and Technology Report 2017						5a. CONTRACT NUMBER		
6. AUTHOR(S) A.S. Keys and H.C. Morris, Compilers						5b. GRANT NUMBER		
						5c. PROGRAM ELEMENT NUMBER		
						5d. PROJECT NUMBER		
7. PERFORMING ORGANIZATION NAME(S) AND ADDRESS(ES) George C. Marshall Space Flight Center Huntsville, AL 35812						8. PERFORMING ORGANIZATION REPORT NUMBER M-1462		
9. SPONSORING/MONITORING AGENCY NAME(S) AND ADDRESS(ES) National Aeronautics and Space Administration Washington, DC 20546-0001						10. SPONSORING/MONITOR'S ACRONYM(S) NASA		
12. DISTRIBUTION/AVAILABILITY STATEMENT Unclassified-Unlimited Subject Category 12 Availability: NASA STI Information Desk (757-864-9658)						11. SPONSORING/MONITORING REPORT NUMBER NASA/TM—2018-219958		
						13. SUPPLEMENTARY NOTES Prepared by the Office of the Director, Center Chief Technologist		
14. ABSTRACT Many of NASA's missions would not be possible if it were not for the investments made in research advancements and technology development efforts. The technologies developed at Marshall Space Flight Center contribute to NASA's strategic array of missions through technology development and accomplishments. The scientists, researchers, and technologists of Marshall Space Flight Center who are working these enabling technology efforts are facilitating NASA's ability to fulfill the ambitious goals of innovation, exploration, and discovery.								
15. SUBJECT TERMS MSFC Research and Technology Report 2017, engineering, science, technology								
16. SECURITY CLASSIFICATION OF:			17. LIMITATION OF ABSTRACT		18. NUMBER OF PAGES		19a. NAME OF RESPONSIBLE PERSON	
a. REPORT U	b. ABSTRACT U	c. THIS PAGE U	UU		148		STI Help Desk at email: help@sti.nasa.gov	
							19b. TELEPHONE NUMBER (Include area code) STI Help Desk at: 757-864-9658	



National Aeronautics and Space Administration
George C. Marshall Space Flight Center
Huntsville, AL 35812
www.nasa.gov/marshall

www.nasa.gov