

# Advanced Mirror Technology Development (AMTD) II Modal Test of a 1.5-m Ultra Low Expansion Slumped Mirror

SPIE August 2018

J. Brent Knight

NASA/MSFC/ES63

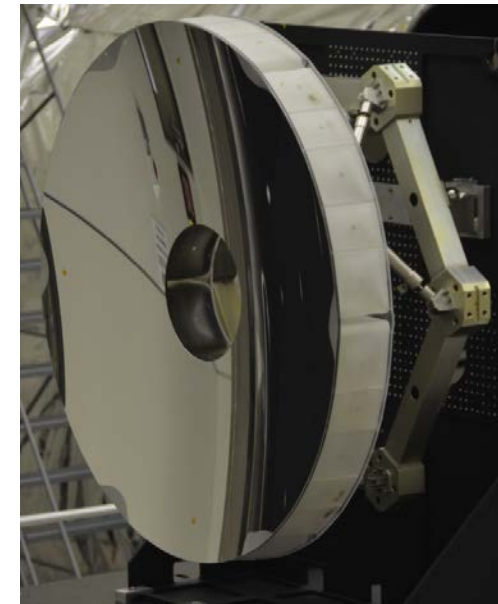



# Agenda

---

- AMTD - Overview
- HabEx - Overview
- Objectives
- Optical System Mechanical Stability
- Structural Dynamic Impacts to Optical Alignment & Stability
- Significance of Verified Structural Dynamic Modes
- Modal Test
- Test of a 1.5 m mirror
- Discussion
- Summary

# Advanced UVOIR Mirror Technology Development (AMTD) for Very Large Space Telescopes



AMTD (2011 to 2017) advanced TRL of processes to design and fabricate 4-meter (& larger) monolithic & segmented mirrors at lower areal density, lower areal cost & lower risk.

Demonstrated stacked core process by making:

- Phase 1: 40-cm thick ULE<sup>®</sup> mirror
- Phase 2: 1.5-m ULE<sup>®</sup> mirror (show lateral scalability)

Validated by Test Thermal & Mechanical Performance Models:

- 1.5m Harris ULE<sup>®</sup> mirror
- 1.2m Schott Zerodur<sup>®</sup> mirror

Developed Modeling & Analysis Tools

- Arnold Mirror Modeler
- Coronagraph Contrast Leakage Modeling Tool
- Thermal MTF
- CTE Homogeneity Estimation Process

Developed process to make ‘as-built’ structural FEM model from X-ray computed tomography data.

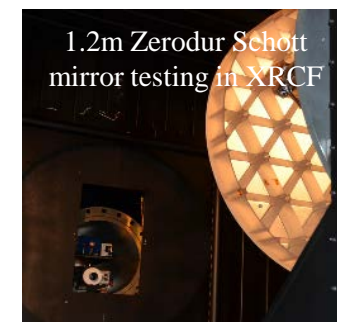
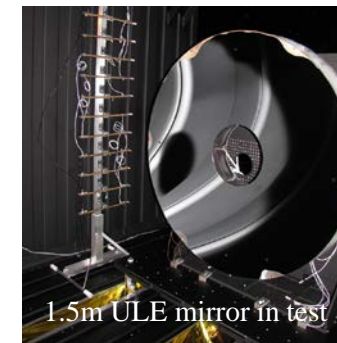
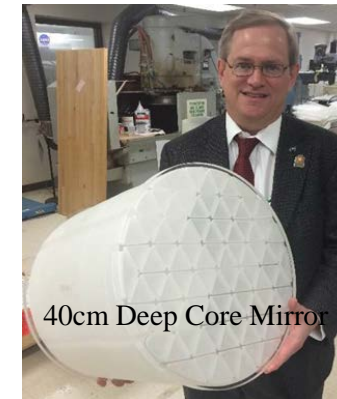

## EXPLORING PLANETARY SYSTEMS AROUND NEARBY SUNLIKE STARS AND ENABLING OBSERVATORY SCIENCE FROM THE UV THROUGH NEAR-IR



### GOAL 1

**To seek out nearby worlds and explore their habitability, *HabEx*** will search for habitable zone Earth-like planets around sunlike stars using direct imaging and will spectrally characterize promising candidates for signs of habitability and life.



### GOAL 2

**To map out nearby planetary systems and understand the diversity of the worlds they contain, *HabEx*** will take the first “family portraits” of nearby planetary systems, detecting and characterizing both inner and outer planets, as well as searching for dust and debris disks.

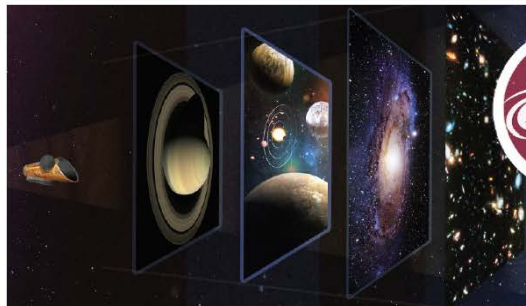

### GOAL 3

**To carry out observations that open up new windows on the universe from the UV through near-IR, *HabEx*** will have a community driven, competed Guest Observer program to undertake revolutionary science with a large-aperture, ultra-stable UV through near-IR space telescope.

from *HabEx* interim report  
URS273294

Pre-Decisional - For Planning Purposes Only

## The HabEx STDT chose these parameters for Architecture A:

Telescope with a 4m aperture

72-m diameter, formation flying external Starshade occulter

Four instruments:

Coronagraph Instrument for Exoplanet Imaging

Starshade Instrument for Exoplanet Imaging

UV– Near-IR Imaging Multi-object Slit Spectrograph for General  
Observatory Science

High Resolution UV Spectrograph for General Observatory Science

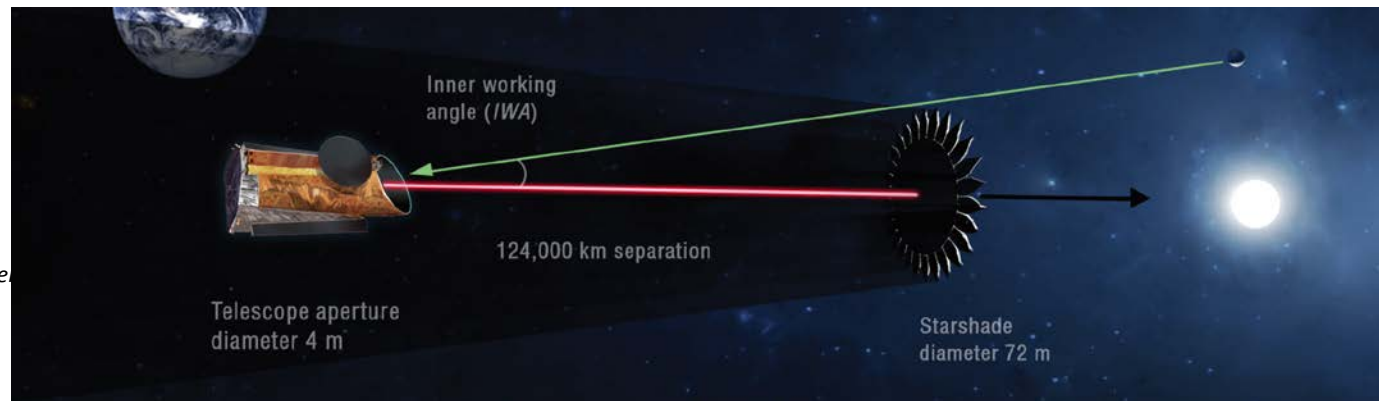

Image from HabEx inter-  
report URS273294

Pre-Decisional - For Planning Purposes Only

# Objectives

- The objectives of this presentation are to:
  - Touch on space optical system overall mechanical stability
  - Discuss mirror structural dynamic modal characteristics
    - Discuss how predicted mirror motion rolls into overall performance assessments
  - Present details and results from a modal test of a 1.5 m mirror

*HabEx structural design is evolving!*

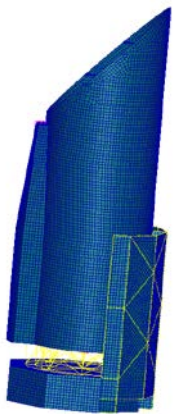

2016

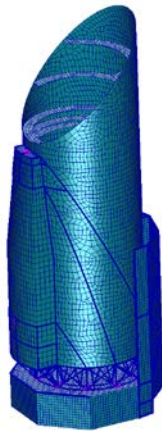

2017

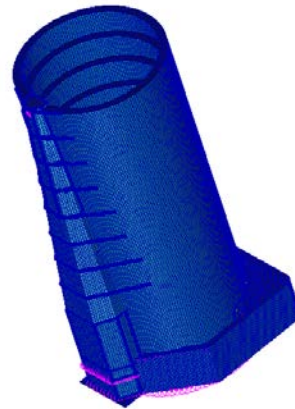

Current (or close to it)

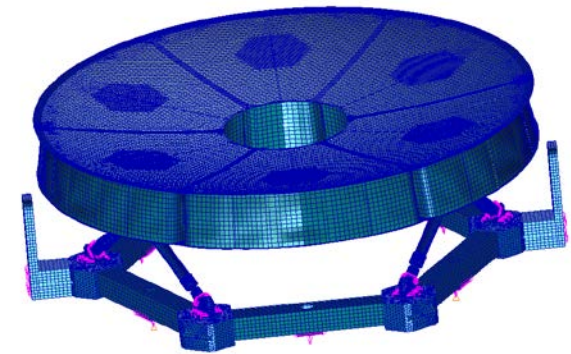

Finite Element Model of a  
1.5 m mirror in a modal test configuration

# Optical System Mechanical Stability

- Optical System Stability is a measure of how *motionless* the system is
  - Sources of motion include structural deformations due to thermal gradients (generally quasi static) and structural dynamics excited by vibrations of onboard equipment such as reaction wheels and/or cryo-coolers as well as transients due to fluid motion
- This talk is ultimately aimed at describing a mirror that was fabricated by Harris as part of AMTD, then was tested to measure modes, and test results were compared to analytical results

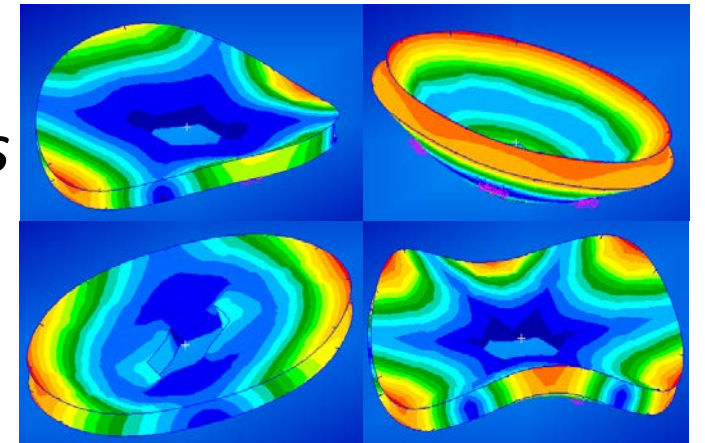

Sample -Mirror vibratory mode shape

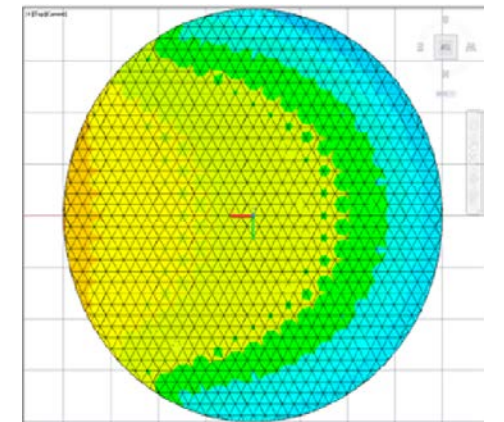

Sample - Mirror Thermal Gradient



# Structural Dynamic Impacts to Optical Alignment & Stability

- Structural Dynamics – structural responses/motion due to time varying (dynamic) inputs (forces, moments, ...)
  - Vibrations from on-board systems such as reaction wheels and cryo-coolers as well as fluid motion in thermal control systems
  - These vibration sources are inputs to stability analyses performed to support design and later performed as part of verification
    - Part of verification is verification of model accuracy
    - Modal tests are performed and models are compared to test data and possibly then correlated to test data
    - Without verification, it is probable that wave front error and/or line of site predictions could be inaccurate

- Forced vibratory motion
  - Vibration waves propagate away from source until diminished

- Modal Responses
  - In put vibrations couple with structural modes (natural frequencies)
  - Responses are amplified
    - Amplification is limited by damping

Forced and modal responses will impact performance to some degree

All structural elements have modal characteristics that will contribute to overall responses

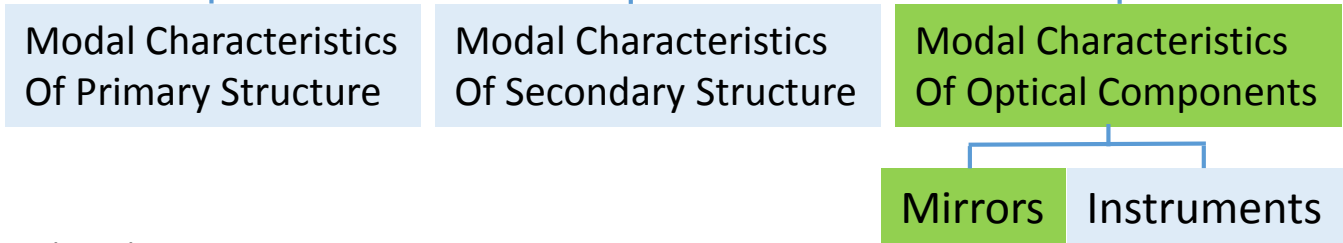



# Significance of Verified Structural Dynamic Modes

- Mode Shapes of simple things such as theoretical SDOF's and common beam/column designs are simple and intuitive
  - Analytical predictions are by and large achievable with closed form solutions - easy
- In Contrast, mode shapes for complex integrated structures can be complex and far less intuitive
  - Analytical solutions are predominantly via Finite Element Analyses (FEA)
- Mode shapes of advanced and extremely light weight mirrors are often symmetric and their mode shape symmetry is intuitive but accurate analytical predictions are via FEA

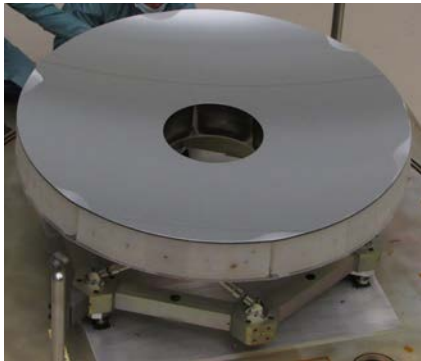

1.5 m Corning Ultra Low Expansion (ULE<sup>®</sup>) material mirror

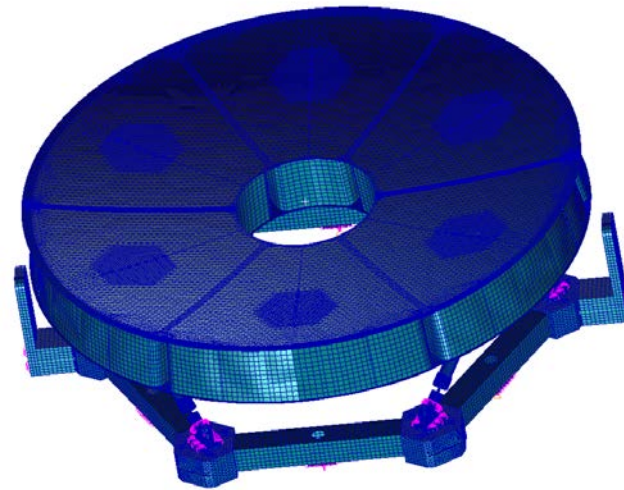

Finite element Model (FEM)  
≈ 720,000 grid points  
As much as 4.3M DOF  
Therefore mass and stiffness  
Matrices that are 4.3 M X 4.3 M

# Significance of Verified Structural Dynamic Modes



- Structural dynamic analyses of HabEx are performed to predict the stability (wave front error and/or line of site) of the system due to known inputs (vibrations and impulses)
  - The HabEx coronagraph requires very little Wave Front Error (WFE)
    - Therefore the Primary Mirror has to be very stable
  - For proof of concept and latter for verification, predictions that roll into Structural Thermal Optical Performance (STOP) analyses have to be accurate
- The accuracy of the predicted vibratory or transient dynamic motion is dependent, in part, on the accuracy of the predicted modal frequencies and shapes
  - In the absence of verified models/mode shapes one would be left with using Uncertainty Factors (UF) in pertinent performance prediction analyses
    - Predicted motions is scaled up to account for uncertainties in predicted motion
    - The cumulative effect of UF's can be significant
  - Modal tests and FEM verification and/or correlation are paramount with respect to verifying a system will meet its performance requirements prior to launch



# Modal Test - Pre-test and Test

- After detailed FEM's are created of a mirror and modal predictions are made, those predictions are verified via modal tests
  - Pre-test analyses are performed in some cases to determine where peak modal responses will occur and where dynamic inputs (excitation) should be applied that will effectively excite modes of interest
  - Those locations would be accelerometer and dynamic load input locations
  - For symmetric structures often engineering judgement is used to locate accelerometer and excitation locations
    - This was the case for the subject AMTD mirror
- In tests, modes are excited via instrumented modal test hammers or stingers that input a specified sinusoidal input ....
  - An instrumented hammer was utilized in this test
- Acceleration is measured and used to mathematically determine mode shapes (displacements)



# Modal Test – Test vs. Analysis

- Comparison of test and analytically derived modal frequencies is straight forward – measured being analytical +/- 5% is generally acceptable
- In contrast, measured mode shapes will be associated with a small number of points whereas analytically derived mode shapes will be associated with many thousands of points
  - Simplified models, Test-Analysis Models (TAM), are created to make the mode shape comparison
  - The FEM is reduced down to the accelerometer locations
    - Effective or equivalent mass and stiffness associated with those points is calculated
    - Mode shapes from the reduced [M] & [K] are compared to test mode shapes
    - The Modal Acceptance or Assurance Criteria (MAC) can be used to compare
      - The MAC is a matrix and a perfect correlation would be the identity matrix
      - Diagonal terms being  $\geq 0.9$  is generally acceptable
      - Off –diagonal terms being  $\leq 0.1$  is generally acceptable

$$\begin{bmatrix} 1 & 0 & 0 & 0 \\ 0 & 1 & 0 & 0 \\ 0 & 0 & 1 & 0 \\ 0 & 0 & 0 & 1 \end{bmatrix}$$



# Modal Test of a 1.5 m Corning Ultra Low Expansion Mirror

# Modal Test

- A modal test of a 1.5 m corning Ultra Low Expansion (ULE) mirror was performed at NASA/MSFC

The mirror and support structure are suspended via bungee simulating A free-free condition

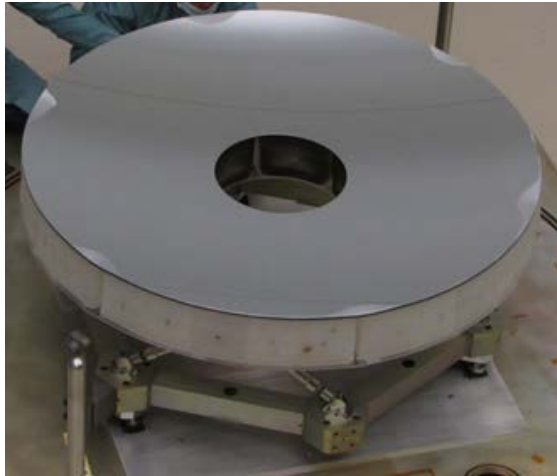

Free-free testing is one way to perform a test and minimize the effects of support structure on the test data

Bungee

# Test Article & FEM

- The mirror was slumped to achieve the prescribed curvature
- The slumping process resulted in geometric imperfections in the mirror
- The mirror developer utilized an in house method of creating a FEM of the slumped geometry
  - The AMTD mirror was stressed in the slumping process beyond what the FEM development process had been applied to prior and was likely beyond the limits to which the method was applicable
  - The geometric imperfections were in the FEM but not to the extent visible in the mirror

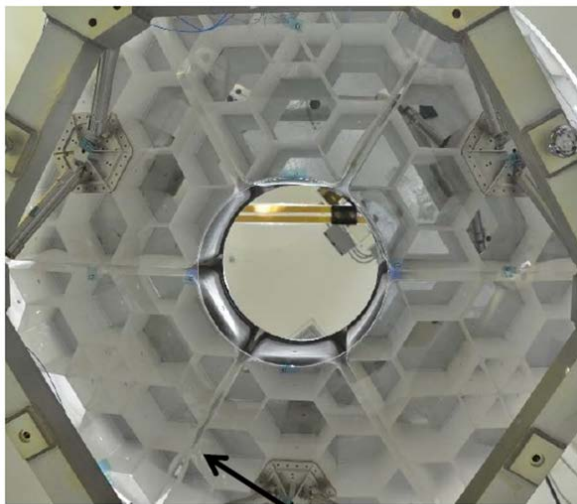

Some ribs are contacting

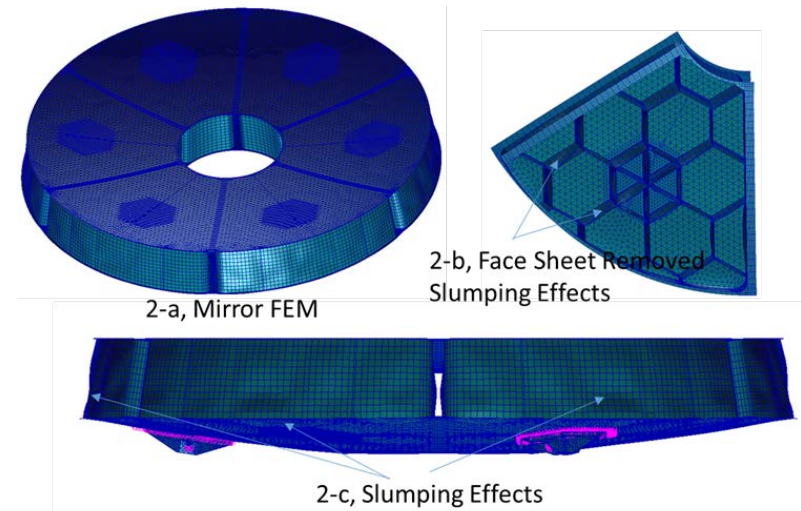
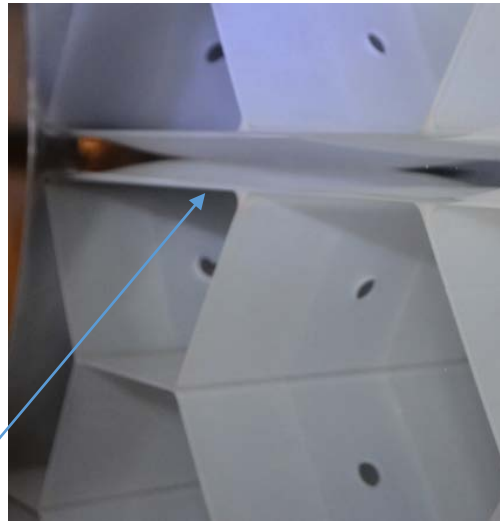

# Modal Test

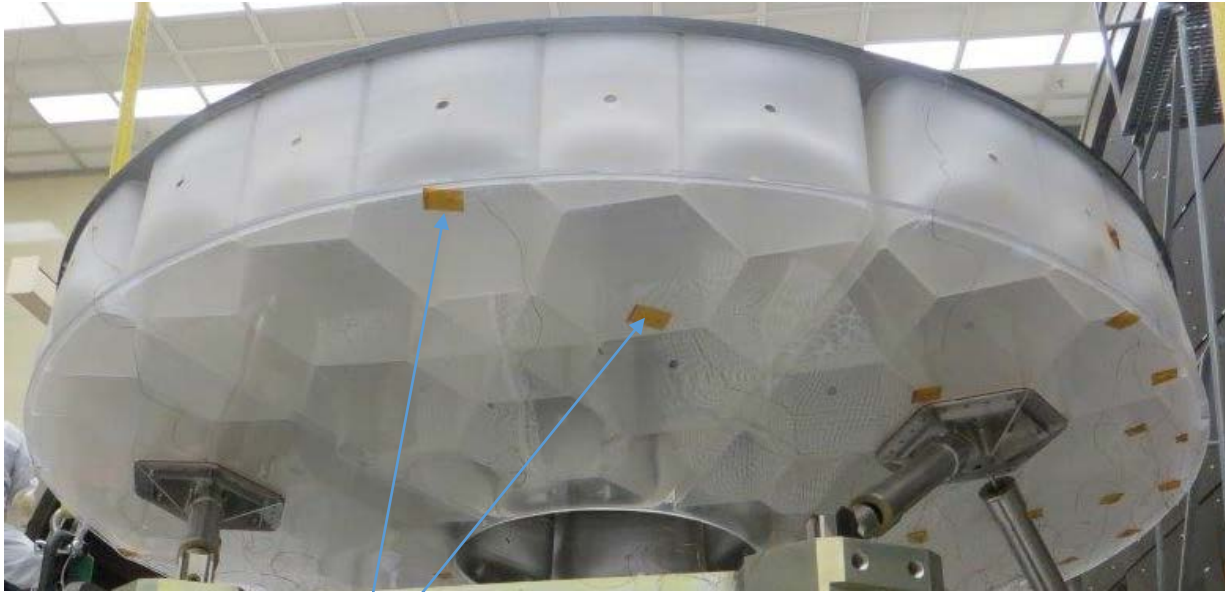

Accelerometer locations

Modes excited via instrumented hammer

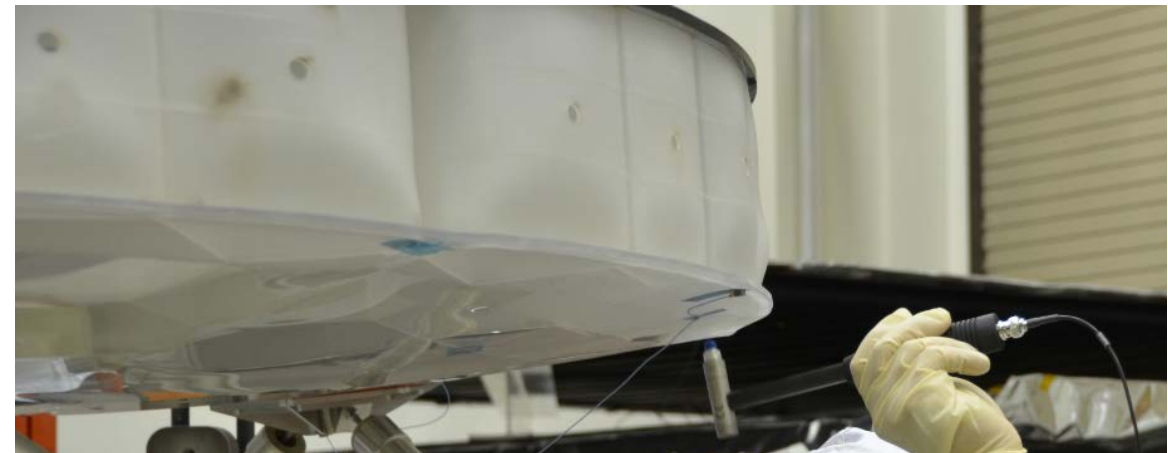



# Test Results

## Frequencies

Modal Frequency, Hz		Difference	
Predicted	Test	Hz	%(of Test)
398.9	414.4	15.5	3.7
395.4	417.2	21.8	5.2
646.1	678.7	32.6	4.8
682.4	707.5	25.1	3.5
834.0	864.1	30.09	3.5
834.8	868.9	34.1	3.9
864.1	877.1	13	1.5

## Mode Shapes

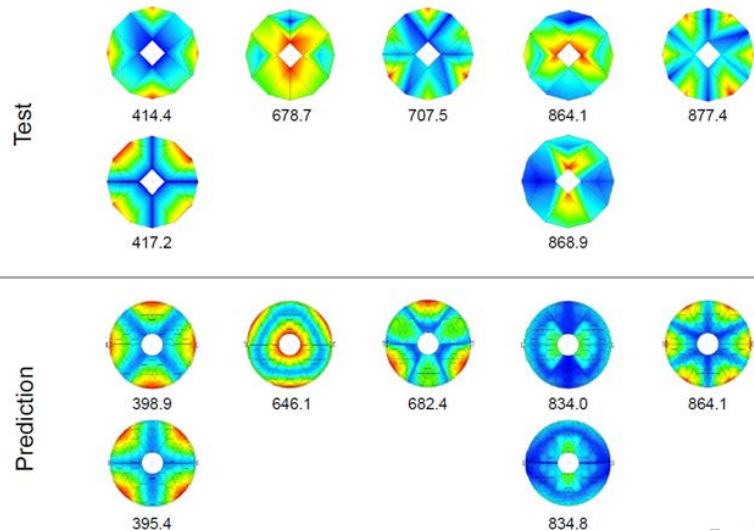

## MAC

Mode	1	2	3	4	5	6	7
1	0.96	0.00	0.00	0.00	0.00	0.00	0.00
2	0.00	0.65	0.00	0.00	0.00	0.00	0.00
3	0.00	0.00	0.91	0.01	0.00	0.00	0.00
4	0.00	0.00	0.07	0.92	0.00	0.01	0.00
5	0.00	0.00	0.00	0.00	0.62	0.00	0.07
6	0.01	0.00	0.00	0.01	0.16	0.85	0.01
7	0.00	0.00	0.00	0.00	0.01	0.01	0.94

- Some MAC values are under par
- Possibly due to differences between the as built mirror and the FEM

# Secondary FEM

- Another FEM of the as built mirror was created via x-ray tomography
- Posttest analyses and comparisons utilizing that FEM are in work
- Perhaps x-ray tomography will prove to be an accurate method of creating a mathematical model of the geometry of a slumped mirror

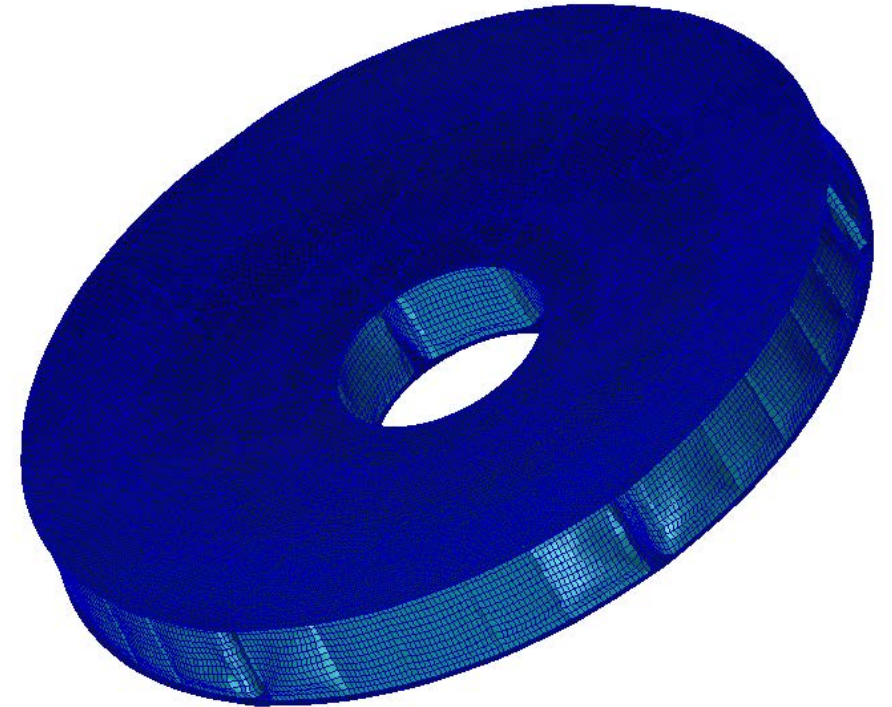



# Discussion

---

- Several MAC values are less than desired
  - Possible causes
    - When the FEM was created by the mirror developer, multiple assumptions had to be made
      - Impacted/influenced the FEM
      - As the mirror was developed, some assumptions did not synch up
      - A new FEM without these assumptions may result in a better comparison
- Furthering the FEM created via x-ray tomography may result in a good representation of as built geometry
- HabEx has challenging engineering requirements
  - The AMTD products are adding value to HabEx and any future large space telescope