

# Utilizing Ionic Liquids to Enable the Future of Closed-Loop Life Support Technology

Brittany R. Brown<sup>1</sup>, Eric T. Fox<sup>2</sup>, Laurel J. Karr<sup>3</sup>, Christine M. Stanley<sup>4</sup>, Morgan B. Abney<sup>5</sup>  
*NASA Marshall Space Flight Center, Huntsville, AL 35812*

Dave N. Donovan<sup>6</sup>  
*Qualis Corp., Huntsville, AL 35806*

Mark S. Paley<sup>7</sup>  
*AZ Technology, Huntsville, AL 35806*

and

Jesse L. McLeroy<sup>8</sup>  
*Auburn University, Auburn, AL 36830*

**Current oxygen recovery technology onboard the International Space Station only recovers approximately 50% of the oxygen from metabolic carbon dioxide, thus requiring resupply mass in order to sustain life onboard. Future long duration manned missions will require maximum oxygen recovery in order to reduce resupply mass. Complete recovery of oxygen can be achieved through Bosch technology. The challenge with this technology is that the solid carbon produced during the process results in undesired catalyst resupply mass. Although there have been several approaches to solve this challenge, in order to totally eliminate the need for resupply only one potential process has been identified. This process is a fully-regenerable Ionic Liquid (IL)-based Bosch system that employs in situ resources. In 2016, efforts were made that proved the feasibility of an IL-based Bosch system. ILs were used to electroplate iron onto a copper substrate and to regenerate the iron by extracting the iron from the copper substrate and product carbon. In 2017, efforts were initiated to scale the proposed technology. Here we report the results of those efforts as well as an IL-based Bosch system concept and basic reactor design.**

## Nomenclature

<i>AR</i>	=	Atmosphere Revitalization
<i>C</i>	=	Carbon
<i>CAD</i>	=	Computer Aided Design
<i>CO</i>	=	Carbon Monoxide
<i>CO<sub>2</sub></i>	=	Carbon Dioxide
<i>COR-CaTS</i>	=	CO <sub>2</sub> Reduction Catalyst Test Stand
<i>Cu</i>	=	Copper
<i>DC</i>	=	Direct Current

---

<sup>1</sup> Project Lead and Reactor Designer, ECLSS Development Branch, Mail Stop: ES62, MSFC, AL 35812.

<sup>2</sup> Ionic Liquid SME and IL Task Lead, Materials Branch, Mail Stop: EM22, MSFC, AL 35812.

<sup>3</sup> Ionic Liquids SME, Materials Branch, Mail Stop: EM22, MSFC, AL 35812.

<sup>4</sup> ECLSS SME and Design Engineer, ECLSS Development Branch, Mail Stop: ES62, MSFC, AL 35812.

<sup>5</sup> O<sub>2</sub> Recovery SME, ECLSS Development Branch, Mail Stop: ES62, MSFC, AL 35812.

<sup>6</sup> Electrolysis SME, Materials Branch, Mail Stop: EM22, MSFC, AL 35812.

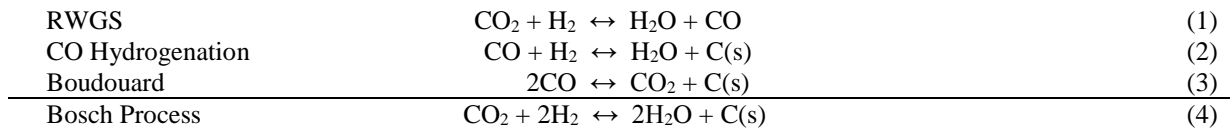
<sup>7</sup> Ionic Liquid Chemist, Materials Branch, Mail Stop: EM22, MSFC, AL 35812.

<sup>8</sup> Summer Intern, ECLSS Development Branch, MSFC, AL 35812.

<i>ECLSS</i>	= Environmental Control and Life Support System
<i>Emim [H<sub>2</sub>SO<sub>4</sub>]</i>	= 1-ethyl-3-methylimidazolium hydrogen sulfate
<i>Fe</i>	= Iron
<i>H<sub>2</sub></i>	= Hydrogen
<i>H<sub>2</sub>O</i>	= Water
<i>HNO<sub>3</sub></i>	= Nitric Acid
<i>IL</i>	= Ionic Liquid
<i>ISS</i>	= International Space Station
<i>LEO</i>	= Low Earth Orbit
<i>MSFC</i>	= Marshall Space Flight Center
<i>NASA</i>	= National Aeronautics and Space Administration
<i>Ni</i>	= Nickel
<i>O<sub>2</sub></i>	= Oxygen
<i>RWGS</i>	= Reverse Water Gas Shift
<i>SmLPM</i>	= Standard milliLiters per Minute
<i>UHP</i>	= Ultra-High Purity

## I. Introduction

WHEN humans begin to explore deep space, all the resupply luxuries experienced during Low Earth Orbit (LEO) missions will vanish. Without these amenities, it will be critical for future life support systems to be reliable and self-sustaining in order to support humans for long duration exploration missions. Oxygen is vital in order for the crew to survive and is provided by the electrolysis of water (H<sub>2</sub>O) aboard the International Space Station (ISS). For long duration missions, higher efficiency processes should be investigated due to the current Sabatier process onboard ISS having a recovery rate of oxygen (O<sub>2</sub>) from metabolic carbon dioxide (CO<sub>2</sub>) of approximately 50%. For long duration manned missions, the efficiency of such recovery should be at a minimum of 75% with a target goal of 90%. The Bosch process is a desirable alternative to the Sabatier process for long duration missions, due to its potential of 100% oxygen recovery. However, there are many challenges with the Bosch process that must be addressed. The Bosch process (shown in Equations 1 through 4) forms elemental carbon that coats and fouls the catalyst compromising the performance of the reaction therefore requiring the catalyst to be replaced.



Historical Bosch systems have produced carbon at a volume of 1.2 kg per day, which quickly fouls the catalyst. For long duration missions, this issue is concerning due to the high amount of catalyst resupply that would be required to maintain oxygen for the crew throughout the entire duration of the mission. In order to solve this issue, advanced development of a fully-regenerable oxygen recovery system is desirable. Regenerable catalysts can be achieved with the aide of liquid organic salts known as Ionic Liquids (ILs). ILs are of particular interest for space applications due to their characteristics such as low flammability, no vapor pressure, and their ability to be modified to be task-specific. Previous studies at NASA's Marshall Space Flight Center (MSFC) have used ILs to extract iron (Fe) and nickel (Ni) from a Campo del Cielo meteorite and electroplate the extracted metals onto a carbon substrate.<sup>1</sup> This same approach can be applied to create an IL-based Bosch system which could eliminate the need for resupply for long duration missions. An IL-based Bosch system is a fully-regenerable oxygen recovery system that involves the following three steps:

- 1.) Designer IL is used to extract Fe and/or Ni from Martian/Lunar regolith, once initial IL is depleted of Fe and/or Ni.
- 2.) Designer IL is used to electroplate Fe and/or Ni onto a Copper (Cu) substrate to generate a Fe/Ni-Cu catalyst substrate to be used in the Bosch process for O<sub>2</sub> recovery.

- 3.) Designer IL is used to regenerate the Fe and/or Ni from the carbon fouled catalyst. Upon completion, the Fe and/or Ni is suspended in the IL leaving behind pure carbon. The solution is then ready to be reused in step two.

In 2015 and 2016, using ILs to reduce catalyst resupply in a closed-loop Environmental Control Life Support System (ECLSS) Atmosphere Revitalization (AR) system achieved a TRL 2.5.<sup>2</sup> Fe was successfully electroplated onto Cu substrates using a traditional method with three different ILs, and electroplated Fe-Cu substrates were shown to be catalytic from all ILs. Also, Fe extraction from a high carbon-content mixture using IL was demonstrated. In 2017, efforts were initiated to scale the proposed technology. Here we report the results of those efforts as well as an IL-based Bosch system concept and basic reactor design.

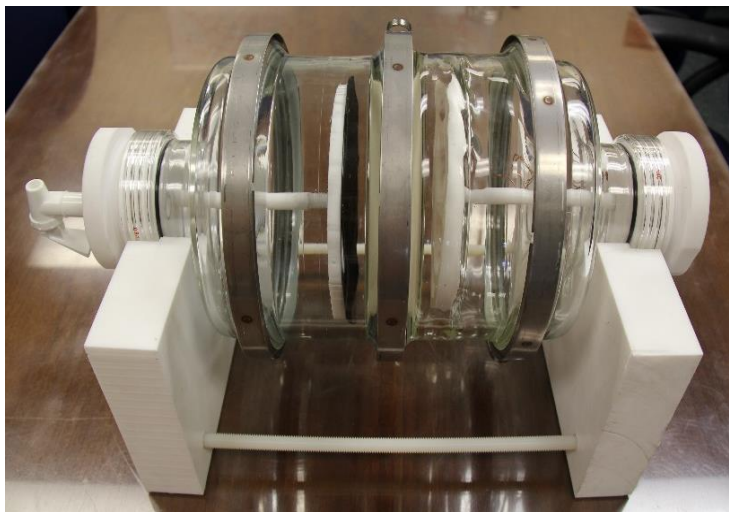
## II. Materials and Methods

### A. Materials

Copper foam was originally purchased from ERG Materials and Aerospace (Emeryville, CA) and cut into 4.6 cm diameter by 1.6 cm thick substrates. Thinner (0.4 cm thick) copper foam was purchased from Nanoshel in Wilmington, DE and cut into 4.6 cm substrates. The two varied thicknesses of copper foam was used as an inert, electrically conductive catalyst substrate were purchased for testing. For carbon formation testing, Ultra-high purity (UHP) carbon monoxide (CO) gas was purchased from Matheson Tri-Gas (Basking Ridge, NJ) and UHP hydrogen and UHP nitrogen gases were purchased from Sexton Welding Supply, Inc. Quartz reactor tubes were purchased from National Scientific, Inc. in Quakertown, PA and Unifrax Fiberfrax S insulation discs were purchased from Unifrax in Tonawanda, NY. For surface cleaning, ionic liquid preparation, and electroplating all wet chemicals used came from Sigma-Aldrich in St. Louis, MO. IL (1-ethyl-3-methylimidazolium hydrogen sulfate (emim [H<sub>2</sub>SO<sub>4</sub>])) was made at NASA's MSFC as previously described.<sup>1</sup>

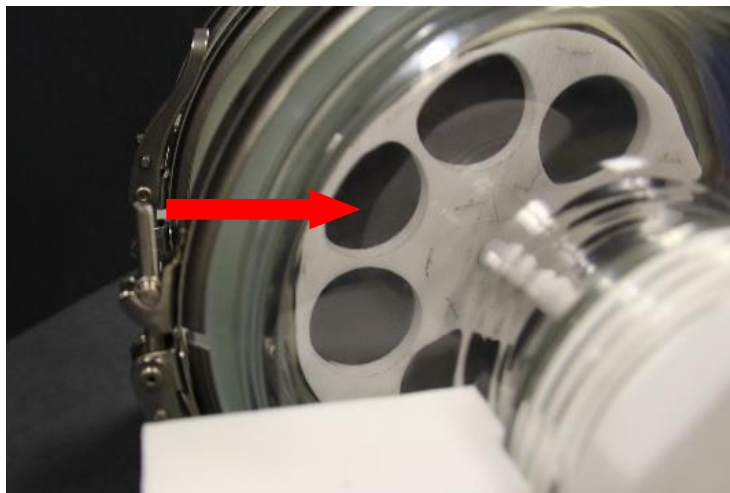
### B. Scaling of Catalyst Preparation

During initial development efforts in 2015 and 2016, copper substrates were plated individually in a single electroplating cell. However, a fully integrated system will require multiple substrates to be plated simultaneously. A new design concept, previously described in great detail<sup>3</sup>, was generated and constructed that allows for up to seven substrates to be plated at a time. The multi-substrate regeneration chamber is shown in Figure 1. The chamber consists of an anode and cathode chamber separated by a quaternary ammonium-functionalized polystyrene anion exchange membrane. The anode chamber contains a 4mg/cm<sup>2</sup> black platinum cloth hydrogen electrode and is shown in Figure 2. The cathode chamber contains the copper substrates that are to be plated during testing. Figure 3 shows the cathode chamber with the substrates secured in the Teflon disc with copper wire threaded through each substrate to make the electrical contact needed during the plating process. Valves are located on the on the endcaps to permit filling and venting without requiring the end caps to be removed. Prior to electroplating, each copper substrate was prepared by rinsing the substrate in 1 M nitric acid (HNO<sub>3</sub>), followed by rinsing in distilled water, vacuum dried for approximately 15 minutes and weighed. The IL used for the electroplating process was [emim] [HSO<sub>4</sub>]. The copper substrates were secured into the Teflon disc holder, IL was filled into the anode and cathode chamber, and the electroplating process was initiated. During the electroplating process, the anode chamber was run with a flow of 7 mL/min at 1 atm of hydrogen between the electrode and the membrane in order to acidify the solution (reprotonation). To prevent the oxidation of the fresh Fe plating on the substrates, the cathode chamber was purged with argon at a flow rate of approximately 7

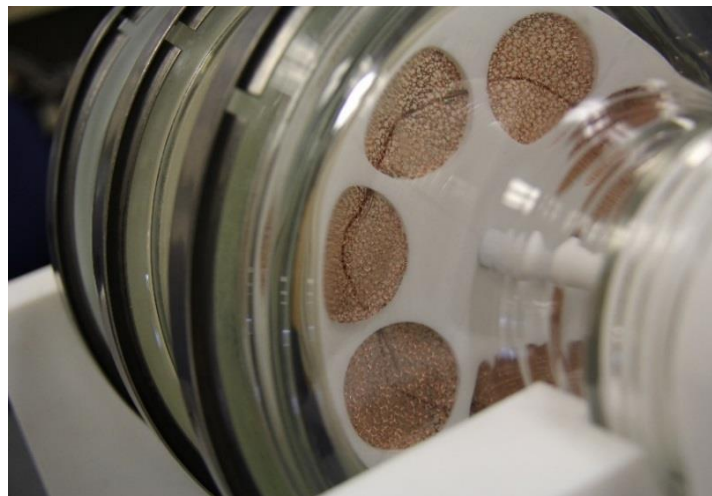


**Figure 1. Multi-substrate Regeneration Chamber.**

mL/min. A voltage of 2.24 volts was applied to the chamber during the process by a traditional DC power supply. Once the desired weight gain of the substrates were achieved (measured by current since the current drops when Fe levels in the IL decreases), the substrates were removed from the chamber, washed in distilled water saturated with argon (to prevent oxidation of the Fe), washed with acetone, and dried in a vacuum oven.



**Figure 2. Anode Chamber containing black platinum cloth hydrogen electrode**



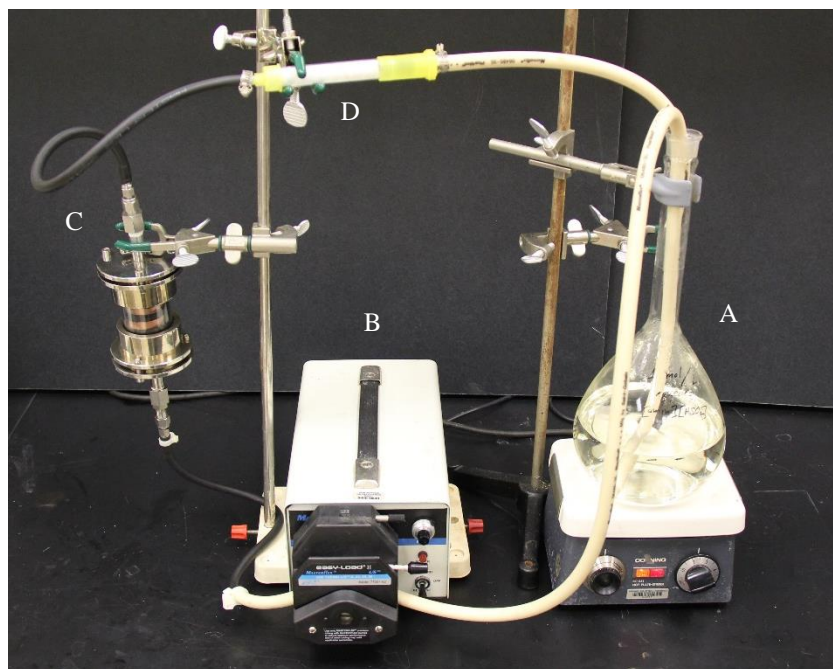
**Figure 3. Cathode chamber containing Cu substrates with electrical connections.**

### **C. Scaling of Catalyst Regeneration**

In a fully integrated system, multiple catalyst substrates must be regenerated simultaneously. A bulk regeneration system was designed and constructed to regenerate multiple carbon coated substrates simultaneously (shown in Figure 4). Prior to bulk regeneration testing, carbon was deposited onto four Fe-plated Cu substrates (three 0.6 cm thick substrate and one 0.3 cm thick substrate) using the CO<sub>2</sub> Catalyst Test Stand (COR-CaTS) at NASA's MSFC. COR-CaTS provides controlled gas flow rates of 10 to 2,000 standard millimeters per minute (SmLPM) as well as all the necessary valving, controls, instrumentation, and safety equipment required while operating carbon deposition testing on the catalyst substrates.

The carbon-coated catalyst substrates were placed into a 10.4 cm quartz tube with the 0.3 cm thick substrate placed closest to the inlet. The substrates and endcaps were separated from each other by copper rings cut from a 3.8 cm diameter Cu pipe. Spacing between the substrates allowed for adequate IL flow to each substrate and ensured

that the substrates were secured in place. Once the substrates were secured in the tube (C), the IL in the reservoir (A), which sits on a hot plate, was pumped through the quartz tube using a peristaltic pump (B). The IL used during testing was a heated 1 mol/L aqueous solution of [emim] [HSO<sub>4</sub>]. Increasing the temperature of the cleaning IL both increases the rate of dissolution of Fe from the catalyst substrate and decreases the viscosity of the IL. Combined, these factors result in IL at elevated temperatures having significantly greater cleaning efficacy than IL at lower temperatures. After the IL was pumped through the quartz tube, the IL was then run through a filter housing unit allowing for carbon to be filtered out of the IL (D). The IL then goes into the reservoir where it continues the process.



**Figure 4. Bulk Catalyst Regeneration Setup.**

#### **D. IL-Based Bosch Reactor Design/Concept**

When designing an IL-based Bosch system reactor, several requirements must be considered. The three main steps to the IL-based Bosch system all occur at varied temperatures requiring the IL based Bosch reactor to be capable of large thermal variations: electroplating of catalyst substrates occurs at room temperature, oxygen recovery via the Bosch reaction occurs at temperatures between 500°C to 600°C, and the regeneration of the carbon coated catalyst substrates occurs at 100°C. When designing the reactor to carry out both the Bosch reaction and electroplating/regenerating of catalysts, the reactor must be capable of multiphase flow. A multiphase flow capability is necessary due to the gases required for the Bosch reaction and the IL required for catalyst preparation and catalyst regeneration. The reactor must also be capable of electrolytic operations required for catalyst preparation (Fe is electroplated onto a Cu substrate, generating the Fe-Cu catalyst substrate for the Bosch process). The data gathered throughout the study were also used as a factor in designing the system.

### **III. Results**

#### **A. Scaling of Catalyst Preparation**

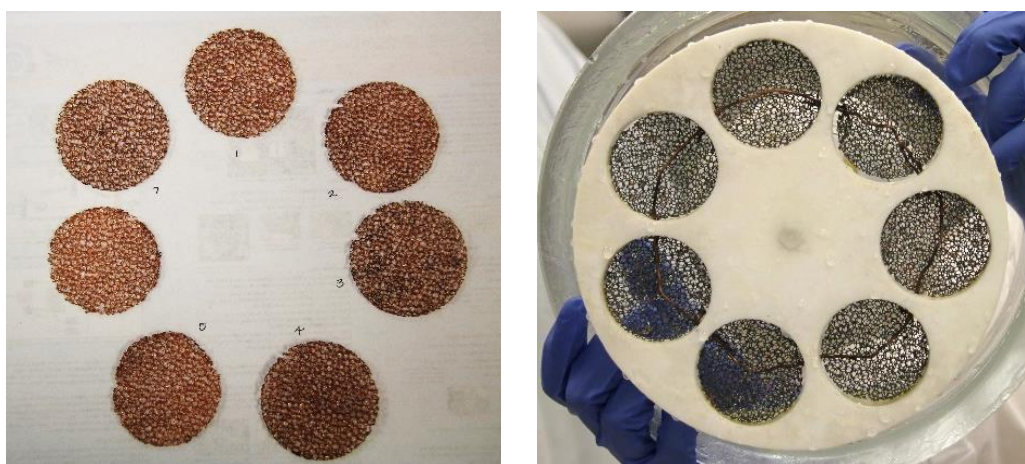
The new design concept that was generated to allow for multiple substrates to be plated simultaneously was successfully tested. The electroplating chamber was originally designed to be run in the horizontal configuration, however due to hydrogen traveling across the anion exchange membrane in previous tests with the single electroplating chamber, the multi-substrate electroplating chamber was run in the vertical configuration to avoid

such behavior. The total run time during testing of the chamber was five hours. To ensure even plating of the Fe on the substrates, the hydrogen electrode was rotated halfway through electroplating.

The weights of each substrate before and after testing is shown in Table 1. A total of 1.6291 g of Fe was plated on all seven copper substrates with an average of 0.233 g of Fe plated on each substrate. Figure 5 shows the copper substrates prior to testing and the copper substrates post testing. Although each substrate was successfully plated with similar amounts of Fe, an even distribution of Fe on each substrate was not achieved. Although each substrate appeared similar in coating upon observation, the uneven distribution of amount of Fe plated was observed once the substrates were weighed individually (shown in Table 1). During testing, the IL solutions showed no signs of color change (color change in the cathode solution would indicate the oxidation of  $\text{Fe}^{2+}$  in the cathode solution of  $\text{Fe}^{2+}[\text{NH}_4^+]_2[\text{SO}_4]_2$  to  $\text{Fe}^{3+}$ , which is undesirable).

**Table 1. Multi-Substrate Electroplating Chamber Run Results.**

Substrate	Pre-Plating Weight (g)	Post-Plating Weight (g)	Amount of Fe Plated (g)
1	1.4700	1.6964	0.2264
2	1.6445	1.7871	0.1426
3	1.5073	1.7315	0.2242
4	1.3902	1.5291	0.1389
5	1.2836	1.6100	0.3264
6	1.5056	1.7538	0.2482
7	1.5630	1.8854	0.3224



**Figure 5. Copper Substrates prior to electroplating (a) and after electroplating with Fe (b).**

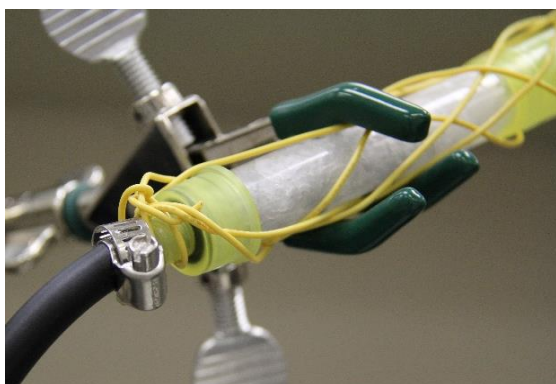
### **B. Scaling of Catalyst Regeneration – Demonstration of Bulk Regeneration**

Several runs were completed in the bulk regeneration system. In Run 1, the IL was heated and the peristaltic pump was set on the highest setting to optimize regeneration time. The measured flow rate produced was approximately 661 mL/minute. After approximately two minutes of run time the chambers inlet end cap separated from the quartz tube despite being securely bolted. Observation of the chamber showed carbon plugging the outlet endcap (shown in Figure 6) which could have caused the pressure to build up in the chamber causing the tube to separate from the endcap. Another contributing factor could be the number of substrates that were in the chamber as well as the high flow rate of IL. Although the duration of Run 1 was only two minutes, the IL showed significant signs of regeneration capability.

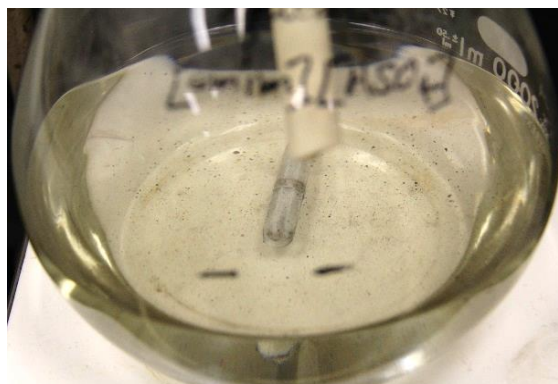


**Figure 6. Carbon plugging the outlet endcap.**

Optimization of the regeneration chamber was made due to the challenges experienced in Run 1. A safety wire cage was installed for the glass wool filter system to prevent failure of the plastic endcaps, and a clamp was secured around the quartz reactor tube to ensure that the endcaps were secure. During Run 2, cold IL was used in the system during testing and the peristaltic pump was set to the lowest setting. Although the lower flow rate allowed for a lower pressure differential than Run 1, the quartz tube is not designed to withstand the pressure and ultimately failed (the quartz tube cracked). Run 2 allowed for a slightly longer run time than Run 1, which allowed the carbon in the IL to reach the inlet of the glass wool filter (Figure 7) and carbon was also observed in the IL container (Figure 8).



**Figure 7. Glass wool filter system post testing with carbon observed at the inlet of the filter.**



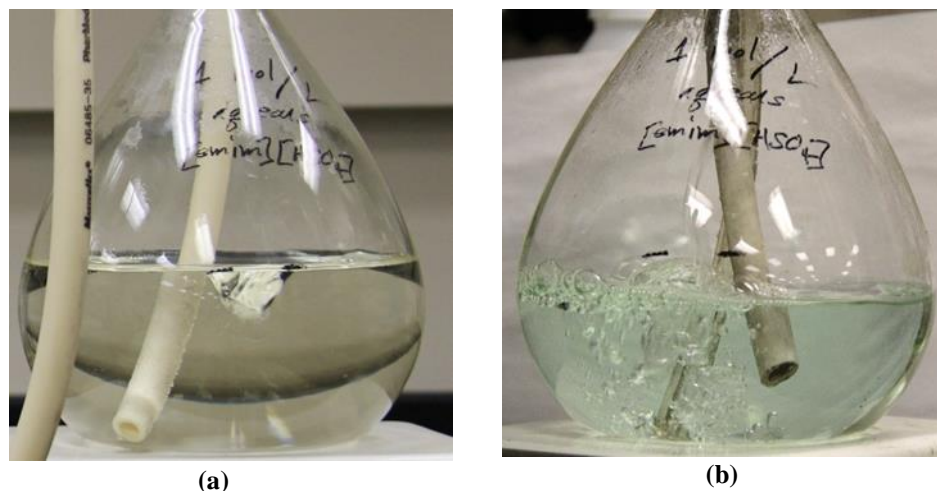
**Figure 8. IL container with carbon residue post testing of chamber.**

Due to the high pressure buildup in the chamber, Run 3 was conducted with the system under a vacuum by reversing the pumping direction. This allowed for a longer run time in which larger amounts of carbon were removed. However, observations of catalyst removal during the run proved the pressurization system showed more regeneration potential than a vacuum system. Prior to completion of Run 3, the pump tubing collapsed due to the filter tube exit being blocked with carbon. Therefore, a larger primary filter and a multi-stage filter system for future runs was required to handle the carbon capacity of the substrates.

To further optimize the regeneration chamber to handle the high pressures generated within the chamber, the quartz tube reactor was replaced with a new chamber (Figure 9) that was rated to withstand 80 psi. The new chamber is a water deionization filter cartridge that contains a filter at the inlet and outlet. Due to the filtering systems tendency to over pressurize the system in previous runs, the chamber was packed with glass wool at the outlet of the chamber allowing the filter system to be eliminated. Results from Run 4 with the new pressurized chamber showed visible amounts of carbon removed from the substrates and the glass wool filter coated in carbon. The clear IL turned a light green color indicating that Fe was present in the IL solution (Figure 10). Although visible amounts of carbon were removed from the substrates, total regeneration of the substrate was not complete. During the run, argon was used to ensure that air was excluded from the system. Air in the system would cause the copper to react and the  $\text{Fe}^{2+}$  would oxidize to  $\text{Fe}^{3+}$ . It was discovered that the argon bubbles that flowed through the chamber provided mechanical agitation which aided the carbon detachment from the substrate.



**Figure 9. Pressure-Optimized Regeneration Chamber.**



**Figure 10. Clear IL prior to testing (a) and light green IL post testing (b) indications Fe removal from Cu substrates.**

Previous efforts to regenerate a single catalyst at a time (catalyst-submerged in a beaker filled with IL and heated to a vigorous reflux for 12 to 24 hours at 100°C) allowed for most of the carbon to be removed from the catalyst substrates. During initial runs in the bulk regeneration chamber, the IL was heated but did not reach temperatures of 100°C. It was thought that the temperature difference was playing a role in the regeneration differences and therefore the regeneration system was further adjusted. In order to ensure minimum temperature distribution from the IL container to the chamber, insulation was installed around the tubing. Thermocouples were installed at the inlet and outlet of the chamber to monitor temperature differences.

During the run, the IL was heated to approximately 96°C. The maximum temperature shown at the inlet of the chamber was 70.1°C and the maximum temperature at the outlet was 67.2°C. The temperature difference between the IL container and the chamber inlet is likely due to the limitation of the thermocouple, because the thermocouple was installed on the outside of the thick walled chamber. Previous runs showed settling of the carbon to be an issue with carbon removal. Carbon would float in the IL solution but then settle back down onto the substrate. To fix this issue, the substrate was suspended on a copper wire and the flow of the IL was changed so that the IL would flow through the top of the substrate allowing for the carbon to fall and catch in the filter below. The regeneration system with the hot IL was run for approximately 8 hours. Post test results look promising as the packed carbon on the inside of the substrate was visibly removed. Light could be seen through the center of the substrate in areas, however



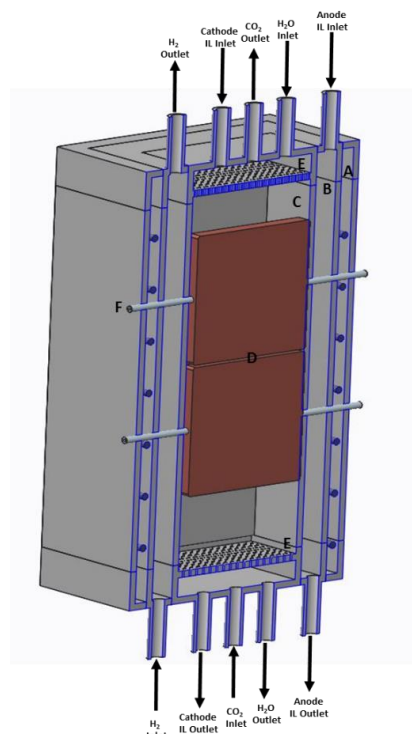
full regeneration was still not achieved. It was determined that the chamber needs to be optimized to allow for some form of agitation to be installed into the system to aid in forcing the carbon loose from the substrates.

### C. IL-Based Bosch Reactor Design/Concept

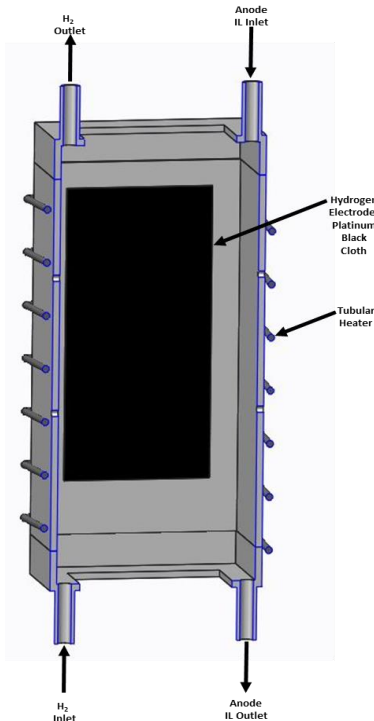
An IL-based Bosch reactor design concept was generated that incorporates three main process: electroplating catalyst onto a substrate, carbon formation via the Bosch process, and regeneration of the carbon-coated catalyst substrate. The Computer Aided Design model (CAD) of the reactor design concept is shown in Figure 11. The reactor will contain a heating element chamber (A), anode chamber (B), and cathode chamber (C). The anode and cathode chambers are used for the electroplating process of the system. The anode chamber (B) is shown in Figure 12. The chamber is composed of titanium and contains the hydrogen electrode which is a platinum surface coated with platinum black. The electrode is rectangular in shape and will be on the inner lining of the anode chamber (shown in Figure 12). The electrodes in the anode chamber will line up with the cathodes in the cathode chamber. The cathode chamber (C), shown in Figure 13, is encased by the anode chamber. In order to withstand the high temperatures required during the Bosch reaction and separate the anode and cathode solutions, the cathode chamber is composed of a ceramic anion exchange membrane. The cathode chamber contains two square copper mesh plates (D). The copper mesh plates are reinforced with a thick copper outer lining to provide structural support for the copper mesh. The copper mesh substrates are capable of rotating and locking into different positions for different processes of the system.

During the electroplating process, the copper mesh plates are rotated and locked into the vertical position (shown in Figure 11). The support rod (F) holding the copper mesh plates contains a port on each end in order to make the electrical connection that is required. The ports allow for an electrical connection to be made to the copper mesh plates as well as a port for a reference electrode to quantify the potential applied to the cathode. The anode and cathode solutions are fed into the chambers by fluid delivery tubes. Once electroplating is complete, the copper mesh plates are then rotated and locked into the horizontal position where they will remain while they undergo carbon formation via the Bosch process (shown in Figure 14). In order to reach the temperatures required for carbon formation and regeneration process, a tubular heater is used. The tubular heater is encased in the heating chamber (A). Tubular heaters were selected due to their ability to bend into different configurations. The bending capability allows for the heater to be wrapped around the anode chamber as well ensure an even temperature profile throughout the reactor.

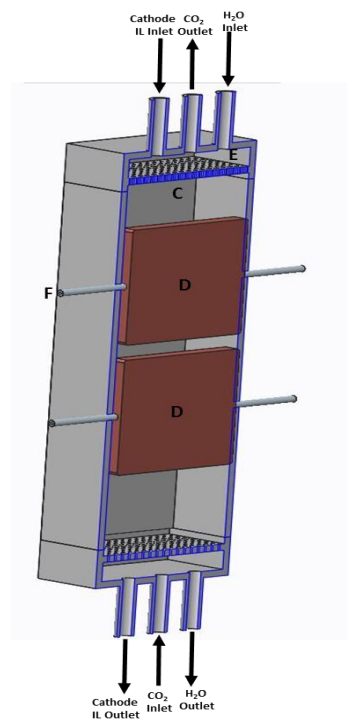
During the regeneration process of the carbon coated copper mesh plates, a combination of vertical and horizontal positioning will be used throughout the process to help aid in agitation of the carbon particles in the copper mesh. The liquid diffuser head (E) is also used to help further aid in the agitation of the carbon. The liquid diffuser head, shown in Figure 15, contains small holes throughout that allows for a jet-like cleaning mechanism. Prior to carbon formation, the anode and cathode chambers are cleaned with water to remove any IL residue. During the carbon formation process, the feed gases are distributed by a gas diffuser head (E) to ensure adequate gas flow distribution through the plates. During the regeneration process, the cathode chamber is pumped with the IL and is run through a filter to collect the carbon that is suspended in the IL solution. Currently, the filter will be replaced periodically when performance is compromised. However, future efforts will be focusing on designing a fully-regenerable filter in order to alleviate resupply mass and eliminate crew interaction.



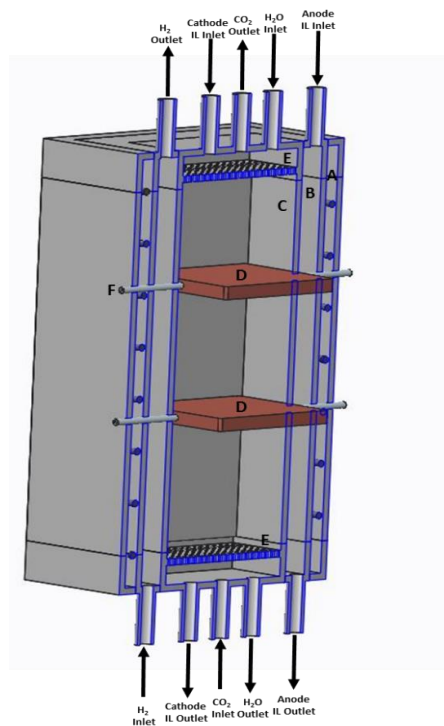
**Figure 11. IL-Bosch Reactor Design**



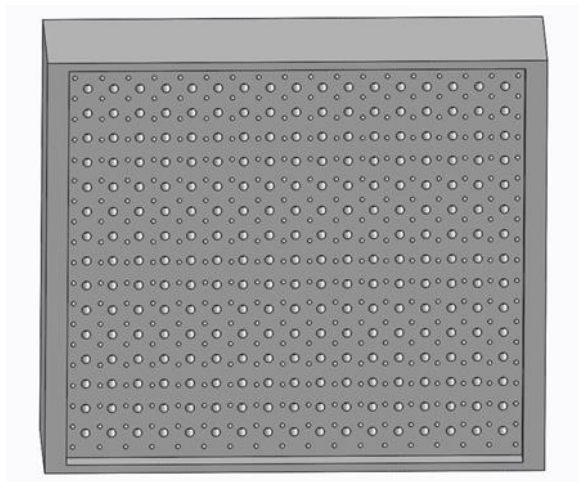
**Figure 12. Anode Chamber of IL-Bosch Reactor Design**



**Figure 13. Cathode Chamber of the IL-Bosch Reactor Design**



**Figure 14. Copper Mesh Plates in Horizontal Position for Carbon Formation Process**



**Figure 15. Liquid/Gas Diffuser. Located in the cathode chamber, it allows for even gas distribution during carbon formation process and agitation during the regeneration process.**

#### **IV. Conclusion and Future Work**

An IL-based Bosch system approach may provide a fully-regenerable technique for recovering oxygen from either metabolic CO<sub>2</sub> or from planetary atmospheric CO<sub>2</sub> by utilizing ILs and in situ resources. Past studies proved the feasibility of such a system and provided a first generation IL-based Bosch system concept.<sup>1</sup> Fe was successfully electroplated onto Cu substrates, all electroplated Cu substrates were shown to be catalytic from all sources, and Fe extraction from a high carbon-content mixture using an IL was demonstrated. The data reported here show the efforts made on scaling up the technology that is required for an integrated life support system, as well as an initial reactor design and concept for an IL-based Bosch system. A multi-substrate plating apparatus and a bulk regeneration system was designed, constructed, and successfully tested. Based on the data gathered throughout the study, an initial reactor design was generated. Future work will involve further optimization of the bulk regeneration system that mimics the design of the IL Bosch-based reactor design, and enhances the carbon cleaning capabilities. Also, a high efficiency regenerable carbon filter system should be further investigated to ensure long-term robustness of the IL. Once a final reactor design is complete, the construction of the IL-based Bosch reactor will begin.

#### **Acknowledgments**

The authors would like to thank Heath Mullins for test stand support, Tom Williams for software support, and Gene Nelson at AG Scientific Glass Company, Inc. for the construction of the glassware for the electroplating chambers.

#### **References**

- <sup>1</sup>Karr, L.J., Paley, M.S., Marone, M.J., Kaukler, W.F., Curreri, P.A., "Metals and Oxygen Mining from Meteorites, Asteroids and Planets using Reusable Ionic Liquids," 2012 PISCES Conference, Pioneering Planetary Surface Systems Technologies and Capabilities; 11-15 Nov. 2012; Waikoloa, HI.
- <sup>2</sup>Abney, M.B., Karr, L.J., Paley, M.S., Donovan, D.N., Kramer, T.J., "Life Support Catalyst Regeneration Using Ionic Liquids and In Situ Resources," 46<sup>th</sup> International Conference on Environmental Systems, Vienna, Austria, July 10-14, 2016.
- <sup>3</sup>Brown, B.R., Abney, M.B., Karr, L.J., Stanley, C.M., Donovan, D.N., Paley, M.S., "Ionic Liquids Enabling Revolutionary Closed-Loop Life Support," 47<sup>th</sup> International Conference on Environmental Systems, ICES Technical Paper, ICES-2017-245, Charleston, South Carolina, 16-20 July 2017.