



TFAWS JWST Special Session



Highly Specialized GSE Required for JWST Verification

Keith Havey, Jesse A. Huguet, Dwight A. Cooke,
Robert L. Day, Harris Corp.

Presented By
Keith Havey



TFAWS
JSC • 2018

Thermal & Fluids Analysis Workshop
TFAWS 2018
August 20-24, 2018
NASA Johnson Space Center
Houston, TX



New Slide Agenda



- Test Overview
- Mechanical Support Systems
- Optical Metrology Systems
- Thermal GSE Systems
- Thermal Modeling & Analysis
- Summary
- Acknowledgements
- Lessons Learned



James Webb Space Telescope (JWST) Successor to the Hubble Space Telescope (HST)

(ref ICES-2018-340)



- JWST has two major differences from HST
 - 6.5m primary mirror (PM) compared to 2.4m HST
 - Temperature 35 - 50 K compared to 294 K HST
- JWST will operate in the infrared region of the electromagnetic spectrum to observe far red shifted stars and galaxies
 - Telescope and all the systems that create the infrared image must operate near 40 K
 - Four science instruments that operate near 40 K
 - Mid-Infra-Red Instrument (MIRI) cooled further to approximately 7 K
- This operating temperature created many challenges for design, assembly, and test of JWST
- Today's presentation will highlight development of the optical, mechanical, and thermal test systems for the OTIS cryotest

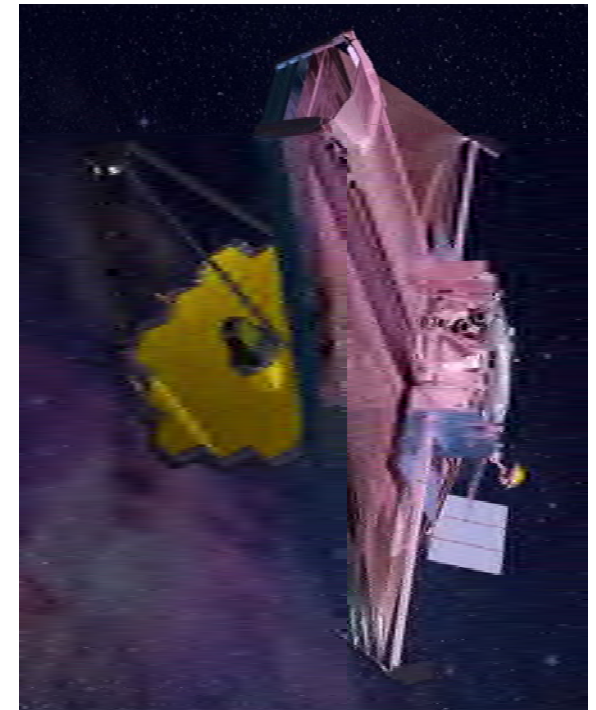



JWST Thermal Test Campaign

(ref ICES-2018-340)



- JWST program developed a methodical sequence of tests to burn down risk by validating each major subsystem prior to the Optical Telescope Element (OTE) and Integrated Science Instrument (ISIM), aka OTIS test.
- Key tests with Harris leadership roles are summarized here.

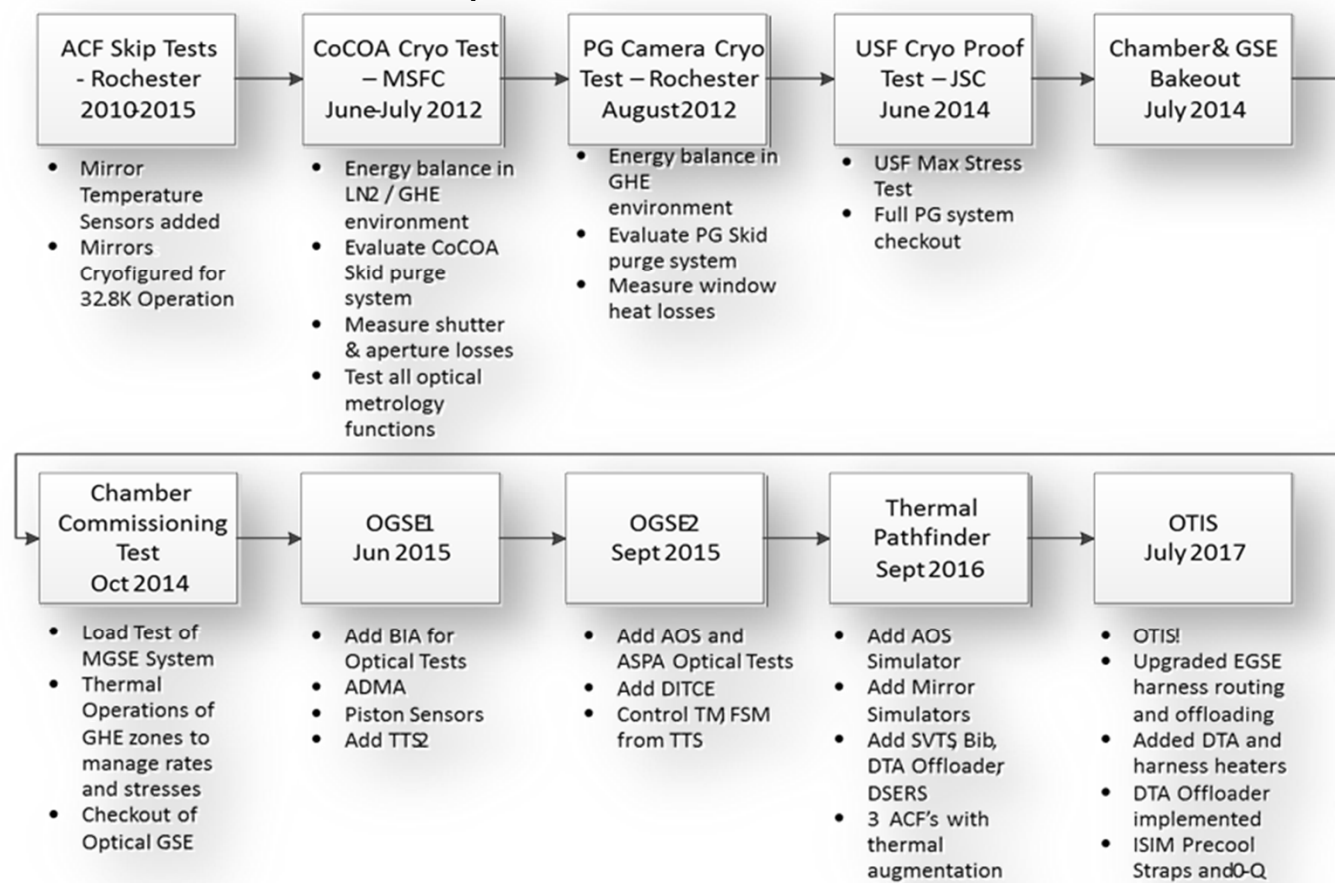



New Chart Thermal-Electrical Test Team – Summary of OTIS Pre-Test Activities



- Extensive effort went into designing the OTIS test and developing test plans and procedures
- Procedures included emergency operations documents for each test set
- Staff rotation planned for over 3 months of test support at JSC in Texas
 - Experienced personnel on each shift
 - Hands-on training for test engineers and operators was an essential element of the plan
- Key Pre-test activities
 - Calibration check of TTS and TTS2 instruments – measured every channel of every LS336 and LS218 and comparing to original response
 - Diode touch tests for all accessible diodes during assembly
 - Inaccessible diodes typically had a response test by disconnecting pigtail cables and monitoring response at the test set
 - Safe-to-Mate tests of all heater channels, measuring resistance and isolation to ground as close to heater as possible, and powering heater and confirming response
 - Test set commissioning
 - After wiring was complete, each test set was checked for full functionality prior to test, including primary and redundant heater control



OTIS Configuration with Harris Cryo-Test Hardware in JSC Chamber A

(ref ICES-2018-340)



- The OTIS test simulated many of the challenges of the flight program
- To provide the most flight-like environment, the test configurations included
 - thermal isolation
 - dynamic isolation
 - precise optical alignment and wavefront measurements
 - stray light control
 - contamination mitigation features
- The required GSE is illustrated here

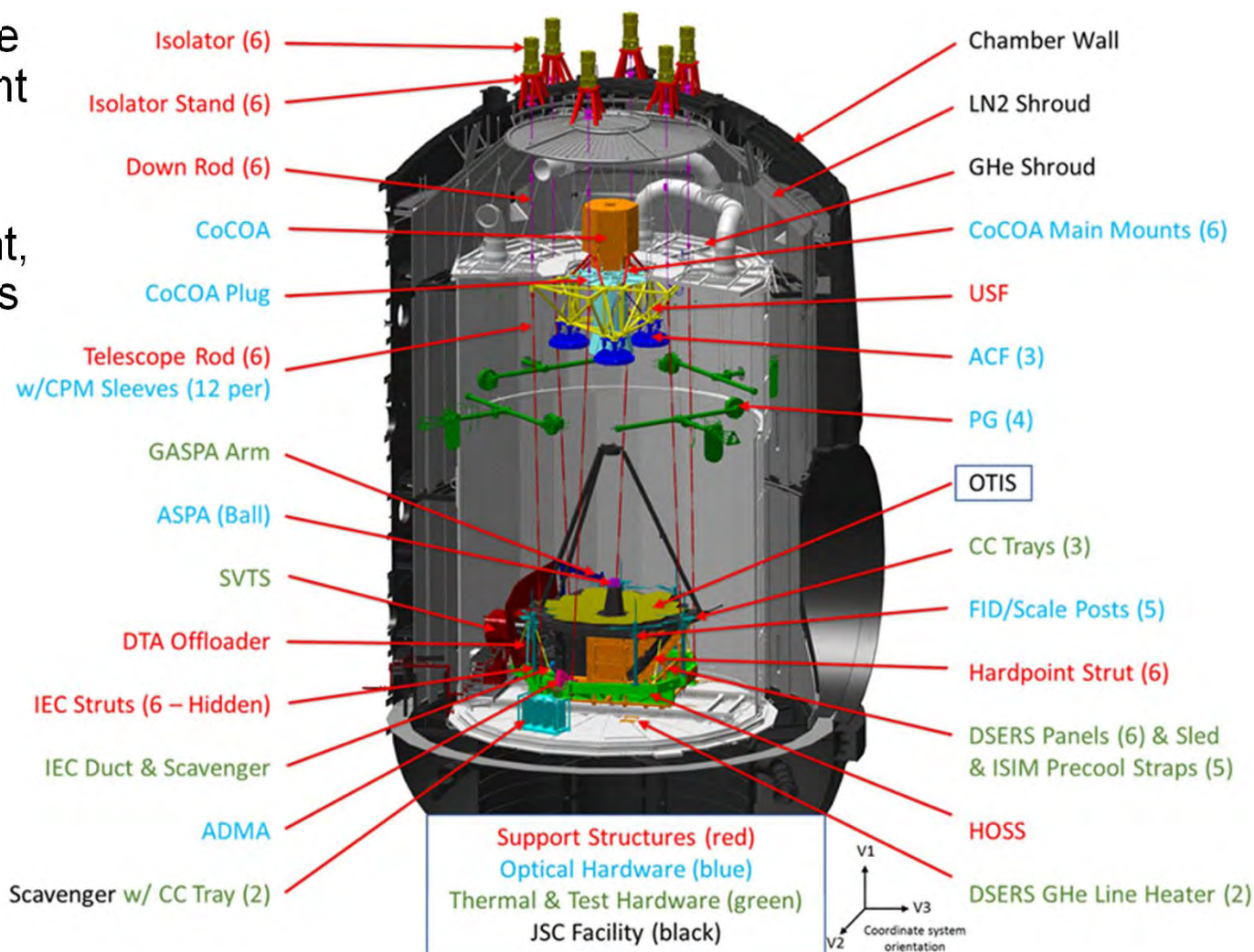

- Dynamic isolation for the 27,000 kg test support hardware
- Titanium rods 27m long reached from ceiling to HOSS
- Upper Support Frame (USF) supported Center of Curvature Optical Assembly (CoCOA) and three auto-collimating flat (ACF) mirrors
- Hardpoint Offloader Support System (HOSS) hung at the ends of the telescope rods and supported OTIS on composite struts

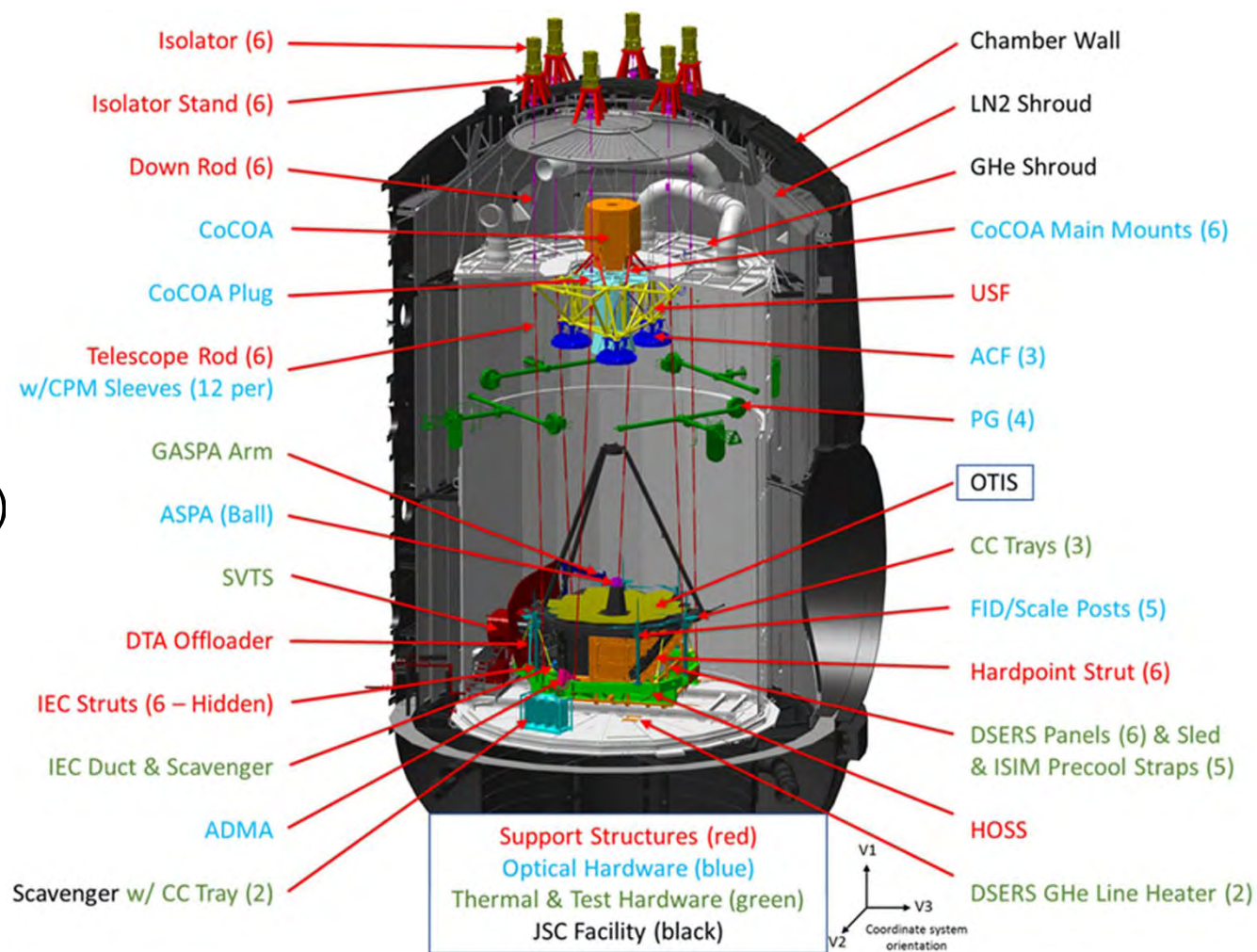



New Slide OTIS Structural GSE Subsystems



- Hanging the system from the top of the chamber reduced alignment uncertainties from:
 - Pumpdown / vacuum shift
 - Cryoshift
 - Dynamics
- Flight DTA is partially offloaded (Not designed for 1-G cryo loading)
- IEC is mounted on HOSS (Flight struts not designed for 1-G cryo loading)

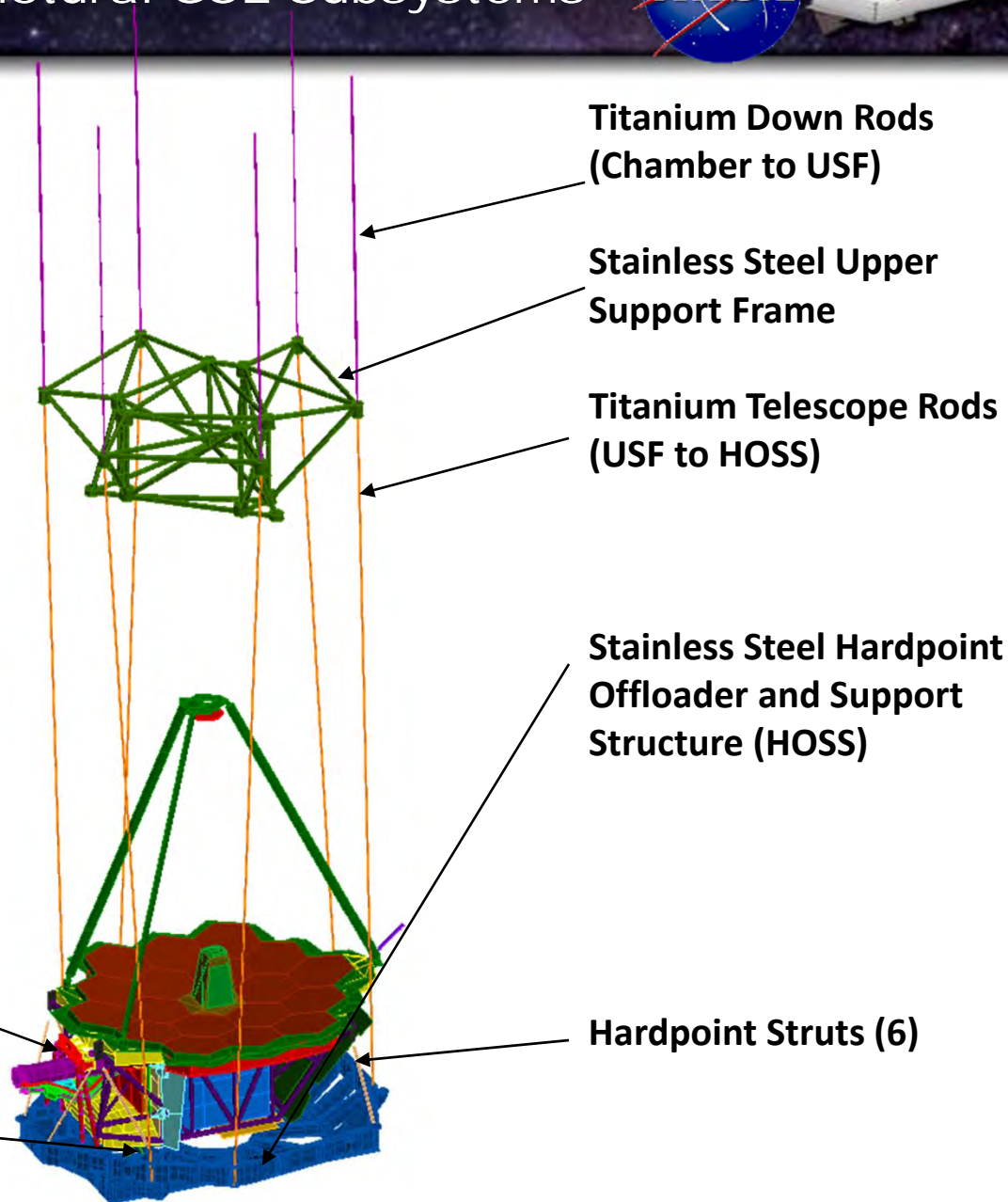

- CoCOA and ACF are GSE Optical Metrology Systems
- PG, ADMA, and the many reflective targets on the scale bars, Telescope Rod Sleeves, and GHe Shroud make up the Cryo-positioning Metrology system (CPM)

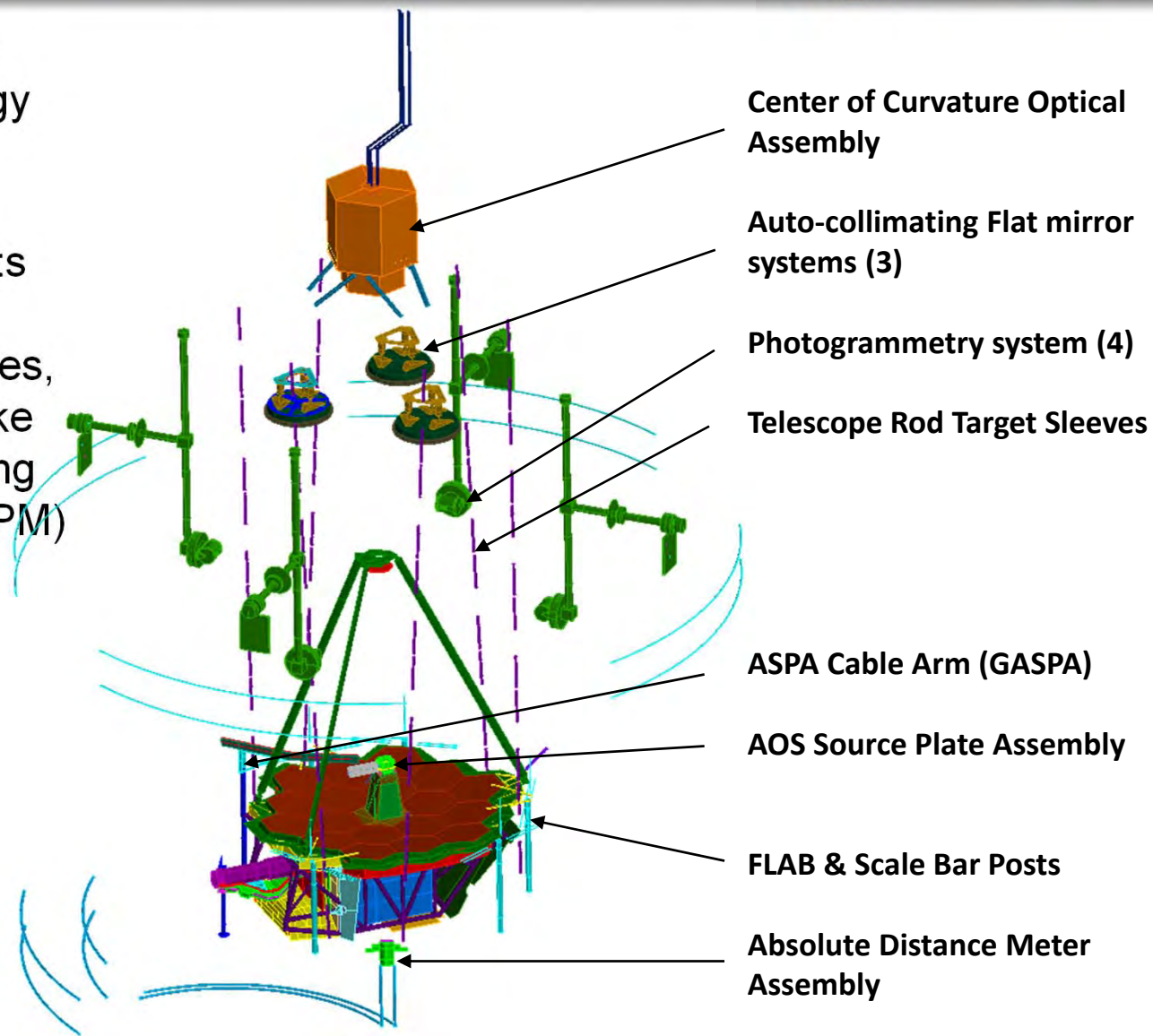

- Center of Curvature Optical Assembly (CoCOA)
 - MWIF & DMI laser sources & electronics inside a large PTE with active air purge
 - Thermal enclosure keeps vacuum-side optics & mechanical hardware at ambient
 - Actuated shutter to mitigate heat input to GHe Cavity
- Auto-collimating Flat Mirrors (ACFs)
 - 3 optically flat (75nm RMS surface figure error) mirrors that collimate reflected source from the AOS & flight optics back toward the flight Instruments
 - Thermal closeouts, GHe flow, and an actively controlled heater ring provide cryo-stability temperatures of $32.8 \pm 1\text{K}$ & $< 0.36\text{K}$ axial gradient
- Cryo-positioning Metrology: Absolute Distance Metering Assy (ADMA) & Photogrammetry (PG)
 - Measure relative position of optics and critical surfaces within $100\mu\text{m}$
 - Uses room temperature, atmospheric pressure electronics – PTEs with active skid controls
 - External temperatures under 70K achieved with GHe cooling and specially designed window coatings.

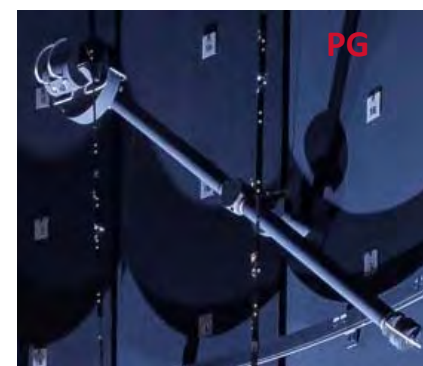
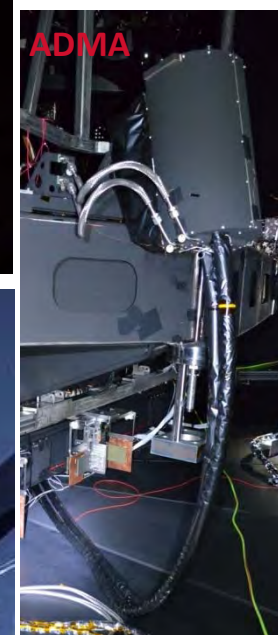
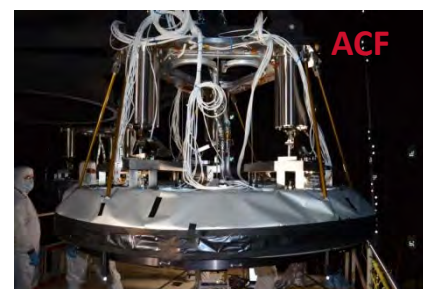
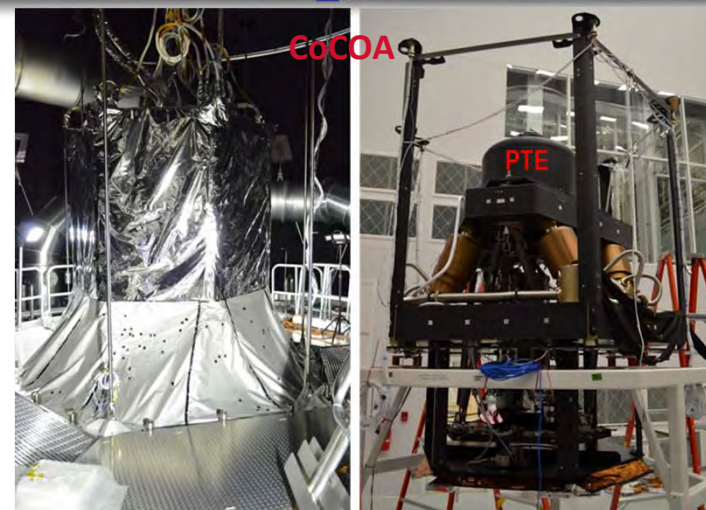



Optical Metrology Systems: Center of Curvature Optical Assembly (CoCOA)

(ref ICES-2018-340)



- CoCOA measured the alignment, phasing, and wavefront of the PM
 - Room-temperature optical assembly supported on USF

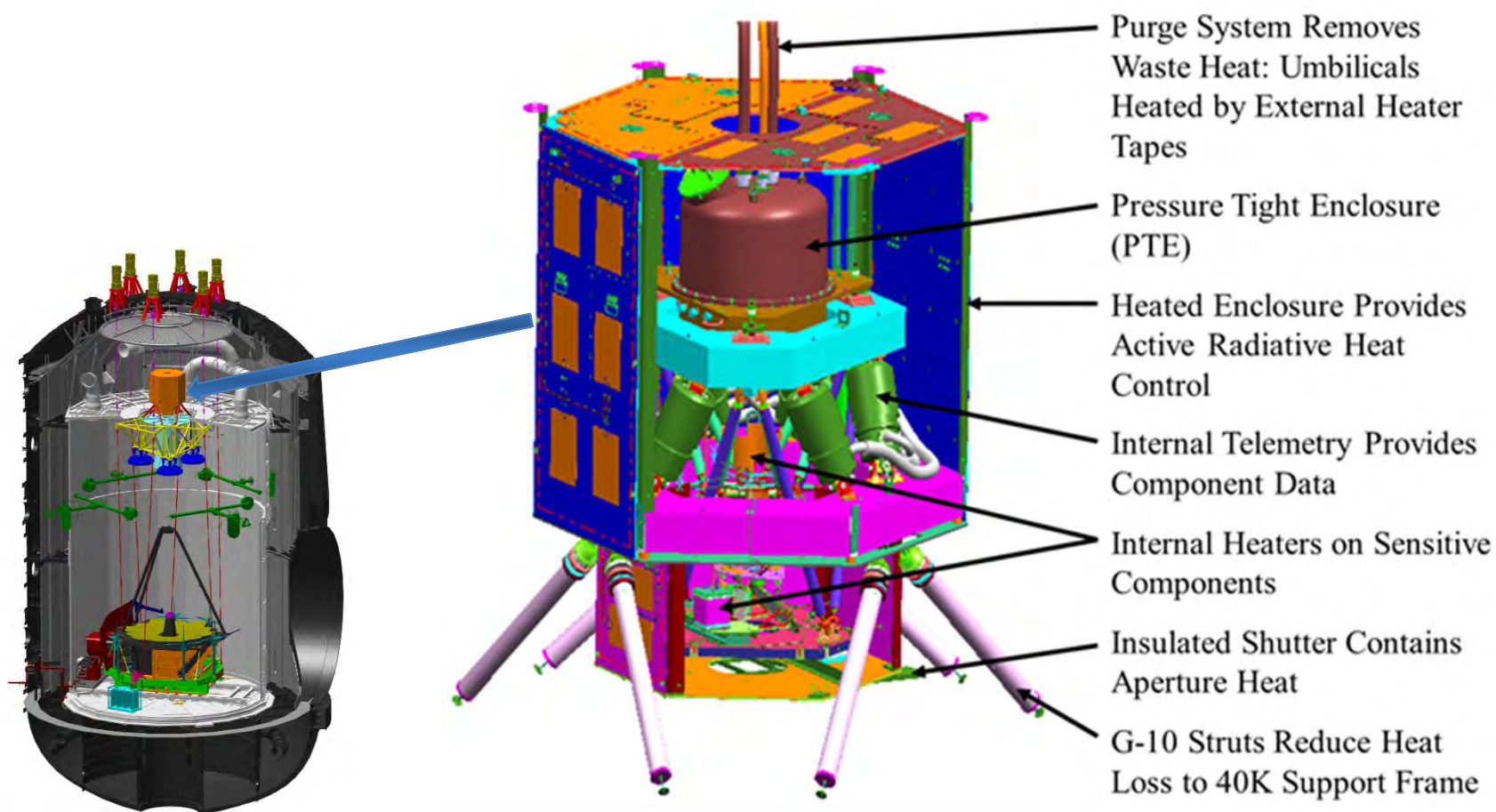

- Three ACF mirror assemblies used in the Pass-and-a-Half (PAAH) test of the JWST flight optics during cryo-stability
- Radiative heaters were also provided for gradient control and for warmup
- ACF average temperature of 32.8 K and gradient limits were met within the cooldown schedule of 35 days

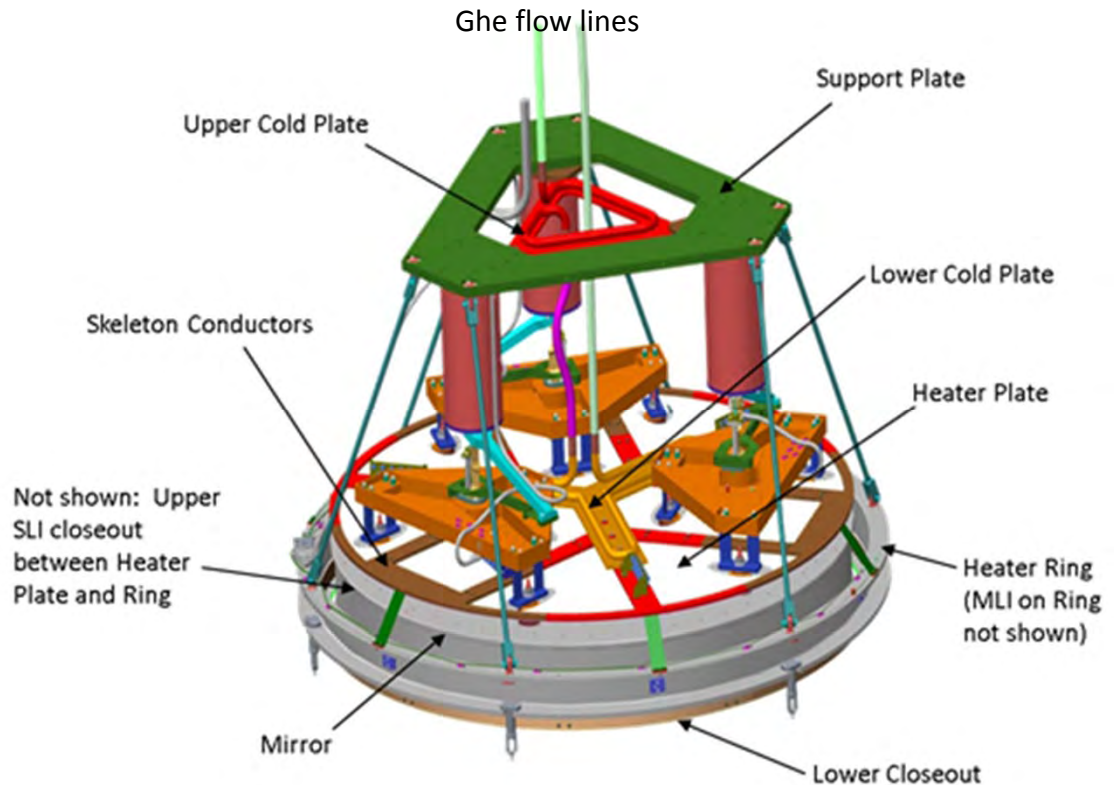
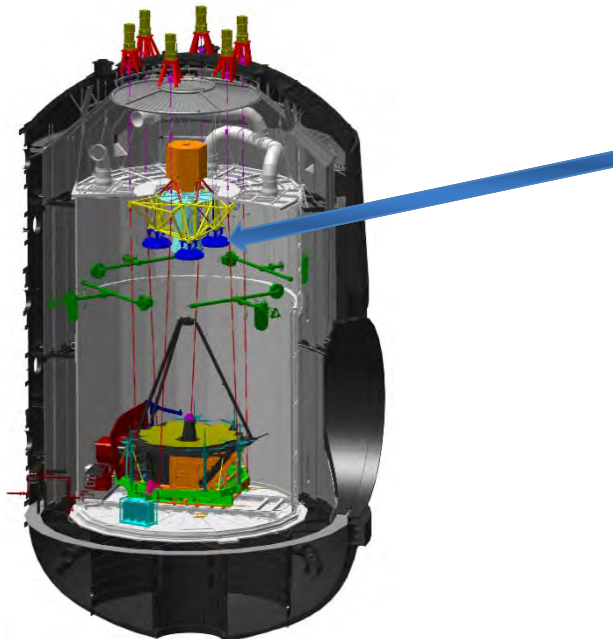



Cryo-Positioning Metrology (CPM) System: Photogrammetry System (PG) and Absolute Distance Meter Assembly (ADMA) (ref ICES-2018-340)



- CPM tracked relative positions of OTIS and GSE in test
- PG and ADMA systems operated with room temperature and pressure interiors but with exterior surfaces <math><70\text{ K}</math> to satisfy stray light and to minimize parasitic thermal loads

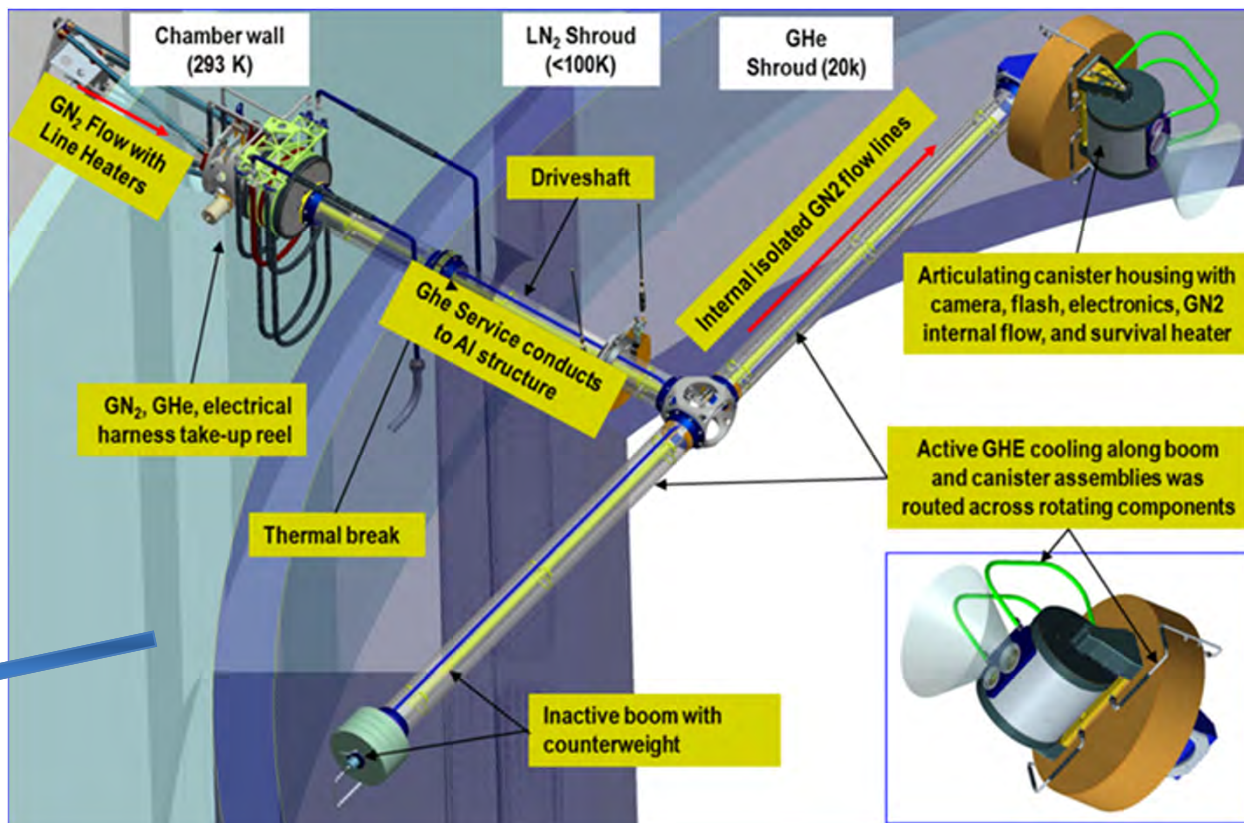
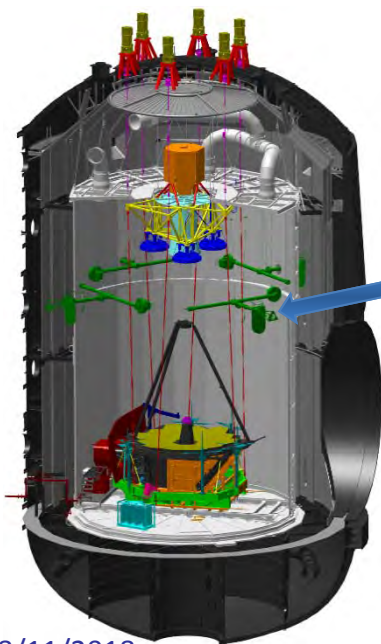



New Slide OTIS Thermal GSE Subsystems



- Harris was responsible for
 - Thermal control of ground support equipment (GSE) boundary conditions
 - Control of OTIS interfaces to flight-like heat loads and temperatures
 - Accelerate test schedule within limitations and constraints
 - Test-only telemetry systems
- +V2, -V2, +V3, & ADIR DSERS & DSERS Closeouts controlled ISIM environment
- HRMS DSERS reduced stray light from harnesses
- IEC DSERS and MLI controlled stray light and contamination from warm flight IEC
- ISIM Precool Straps attached to DSERS and provided conductive cooling path from flight radiators to GHe
- SVTS & Bib mimic flight Spacecraft BUS and Sunshield

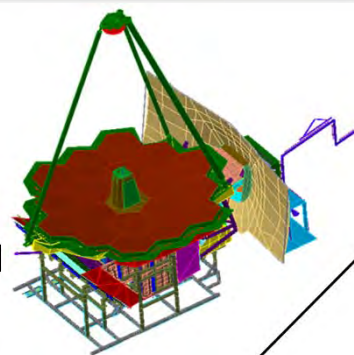

- SVTS:
- L5 Simulator
- GSE Bib
- Hub Heaters & SLI
- HTSA
- Platen
- Cold Box (Warmbox inside)
- MIRI Chase
- Assembly Platform

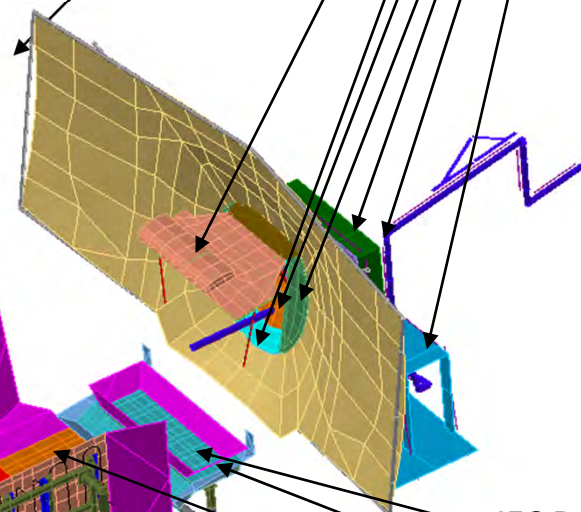

- DSERS Closeouts
- +V2 DSERS
- +V3 DSERS
- ADIR DSERS
- DSERS Inline Heaters
- V2 DSERS
- DSERS Sled & Frames

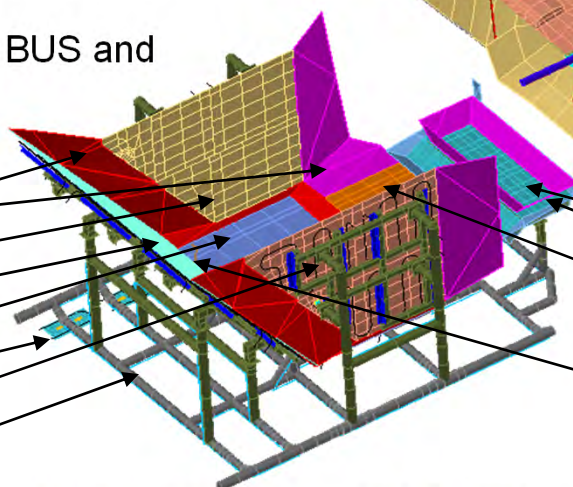

- IEC DSERS
- IEC Closeouts
- HRMS DSERS
- ISIM Pre-cool Straps

- DSERS GSE provided a radiative sink for the flight radiators
 - High emissivity / IR absorption of 0.98 for simulated heat loss to space
 - Panel and in-line heaters were assisted with gaseous helium (GHe) / panel temperature control
 - Test objective during cryo-stability was met keeping the ISIM DSERS panels stable at 20 K with low spatial panel gradients over very large surfaces

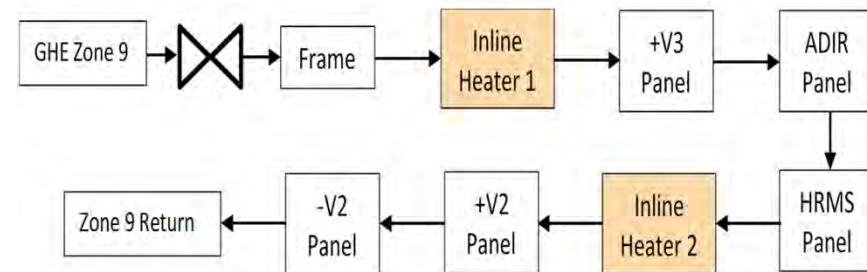
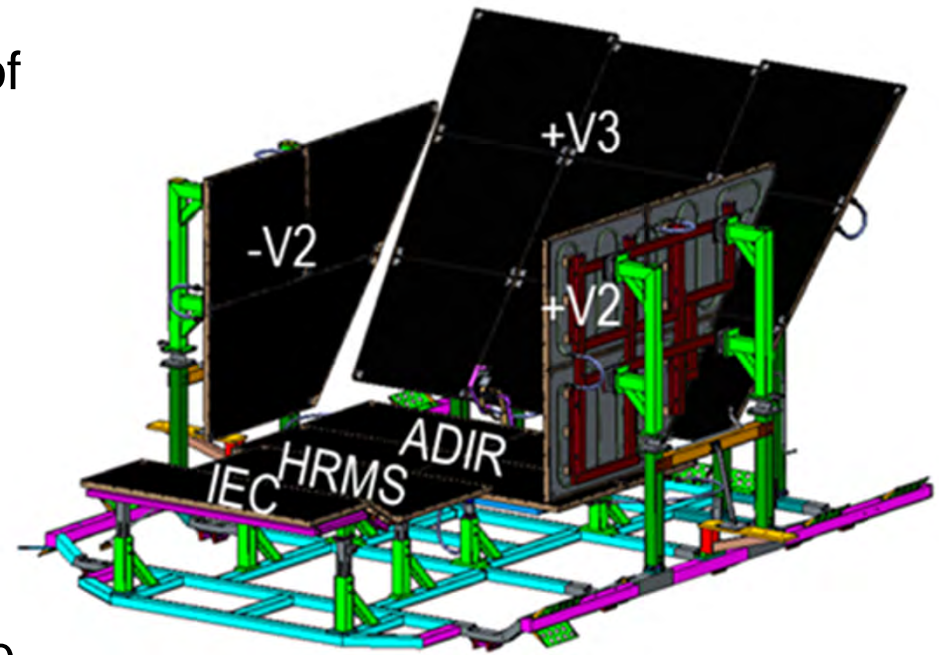

- Instrument Electronics Compartment (IEC) DSERS GSE had challenging thermal, mechanical, stray light, and venting requirements
 - IEC DSERS was cooled and warmed with GHe and had an emergency heater to protect the flight electronics in event of test failure
 - MLI blanket assembly accommodated the large cryo-shift and closed out the volume below the IEC with light-tight seams at the conformal shields
 - Venting from the warm IEC was managed with a G-10 vent duct attached to the +V2 collar of the IEC to direct outgassing from inside the IEC down to a dedicated scavenger plate on the HOSS
 - All thermal test temperature control requirements were met

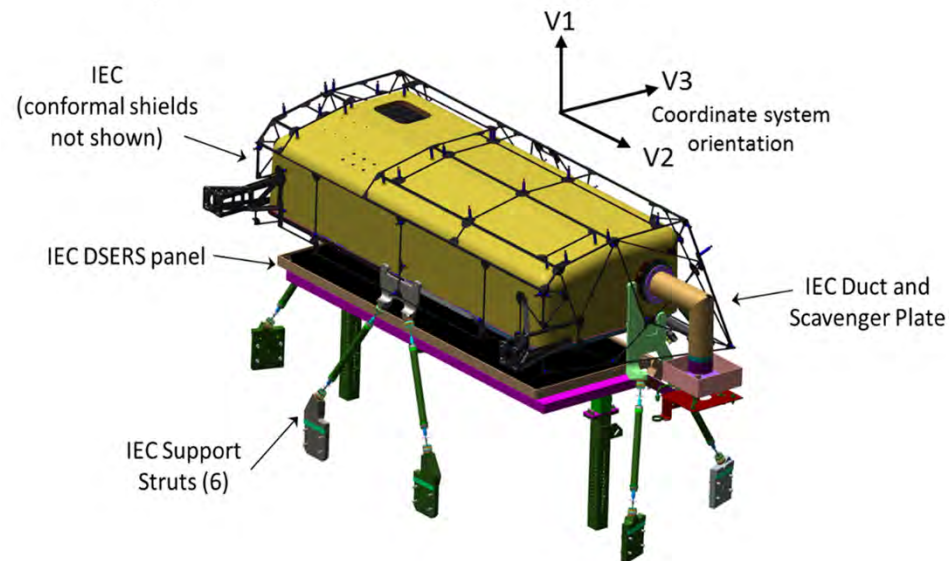

- 6 carbon fiber composite struts with MP35N flexures
 - Supports OTIS for the 1-G environment
 - Deviates from the flight condition
 - Bipod arrangement on $-V3$ end, Monopod at $+V3$
 - 25-layer MLI blankets on outside keep radiative effects low

- Heat leakage requirements
 - 2 mW on monopod struts, 6 mW on bipod struts
 - More heat is acceptable at the bipods due to the warm Core Area on $-V3$ end of OTIS

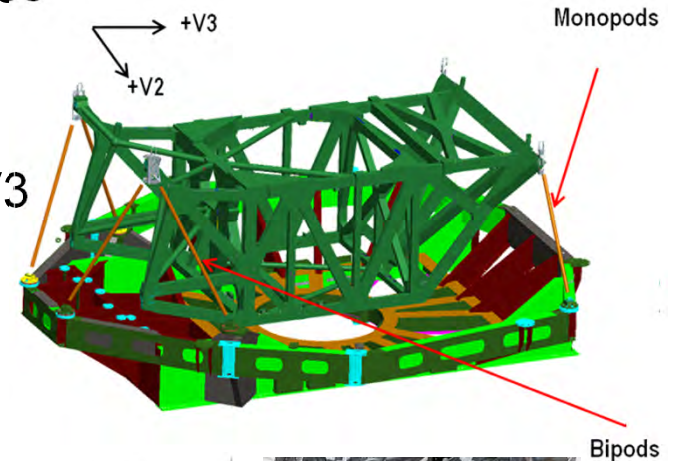

Even with low conduction and insulated struts, active thermal control was required to meet heat leakage requirements

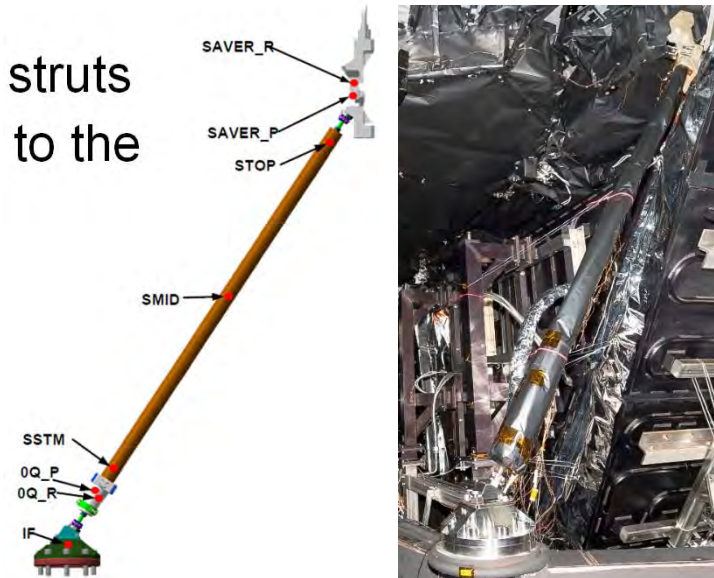



Hardpoint Strut Heater Operation

(ref ICES-2018-333)



- A semi-automated routine was configured in the test set for changing setpoints during cooldown
- The 0-Q heater applies heat such that the temperature at
$$\text{STOP} = \text{SAVER_P}$$
 - With zero gradient across the flexure, there is no heat transfer
- The test set enabled the setpoint of the heater to be the current temperature of SAVER_P + an offset
 - Heater setpoint was updated every 2 minutes
 - User supplied offset modified to trim the heat flow to zero

The automated setpoint updating was able to track the cooldown of OTIS while keeping heat leakage small

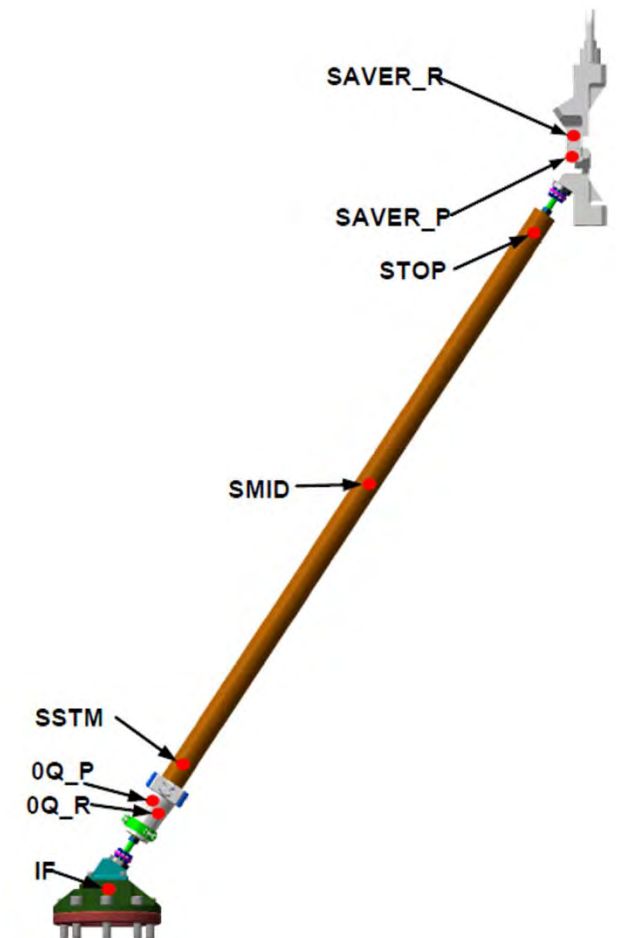

- ISIM precool flexible aluminum straps bridged the five ISIM radiators to the back side of the DSERS
 - Provided a heat sink to accelerate ISIM cooldown
 - Managed conductive heat flow from the ISIM to DSERS below 6 mW at thermal balance
- Several thermal-mechanical challenges were required to accommodate the large cryo-shift
 - Flexible strap and sensors accommodated the large motion without shorting the straps or SLI
 - GHe flow piping lines floated without making contact

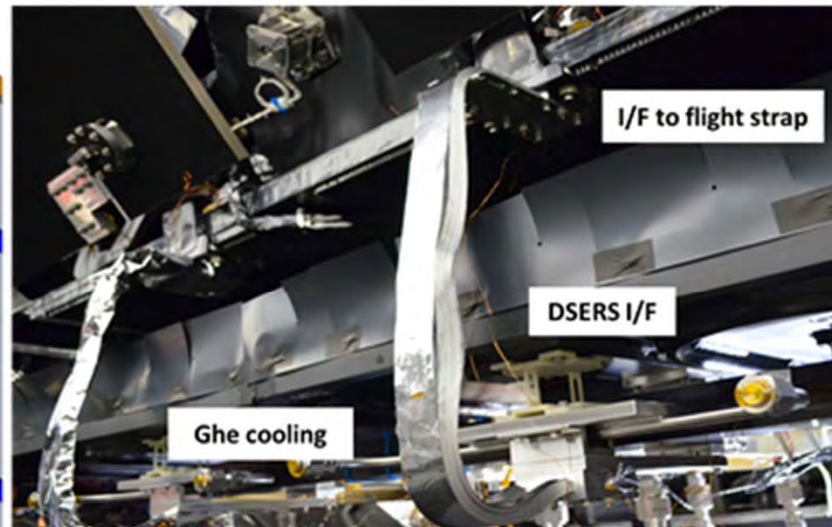
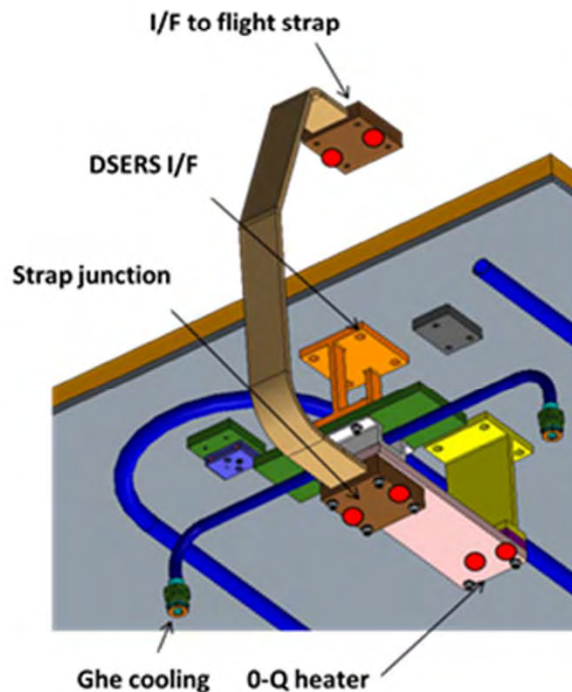

- High purity aluminum strap
 - Accommodates relative motion from OTIS to support structure
- GHe tube under the strap serves as a cold sink
 - GHe flows during cooldown, shuts off for 0-Q phase
 - Conduction path optimized to throttle heat flow
- 0-Q heater located at end of assembly for precision control
 - 0-Q heater designed to perform with automated setpoints like hardpoint struts
- 0-Q achieved when gradient between strap junction and I/F to flight strap is zero

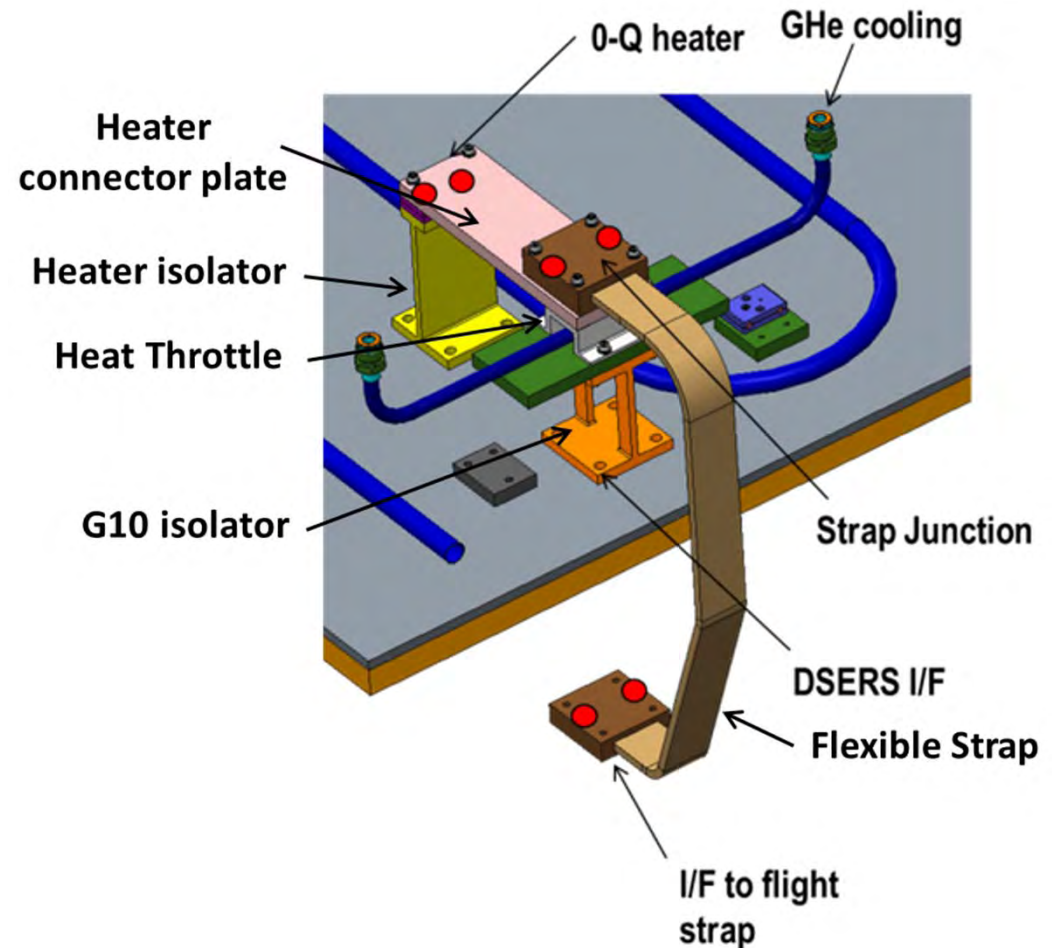



Pre-Cool 0-Q Performance

(ref ICES-2018-333)



- All 5 pre-cool straps kept heat flows near 0 W
 - Some spikes in heat flows, with largest on NIRSpec FPA
 - Corresponds with instrument system heater power/dissipation signature
 - Attempts to correct for the spikes were detrimental to the other direction of the oscillation
- Heat leakages for 0-Q periods (excludes E2E Conduction and MSA Annealing tests) are shown in the table
 - Negative values are heat flow out of OTIS, positive values are heat flow into OTIS
 - Heat from temperature uncertainty shows uncertainty from sensor calibration

	Average Heat Leak (mW)	Maximum Heat Leak (mW)	Minimum Heat Leak (mW)	Standard Deviation (mW)	Heat from temp. uncertainty (mW)
NIRCam	-0.39	1.95	-2.85	0.82	1.84
NIRSpec FPA	-0.08	5.70	-4.24	1.31	2.13
NIRSpec OA	0.29	2.75	-1.58	0.71	2.89
FGS	0.18	2.03	-0.84	0.45	1.68
MIRI	0.47	1.29	-0.22	0.33	3.02

- SVTS simulated several flight hardware features
 - Sunshield Layer 5
 - Hub and rim assembly
 - Harness interconnect panel ICP4
 - Stray light bib
- SVTS features unique to OTIS test
 - A thermal “chase” for the MIRI GSE cryocooler lines
 - Cable chase and vent flow control path with ducting and scavenger plate
 - DTA heater
 - Large cryo-shift accommodation

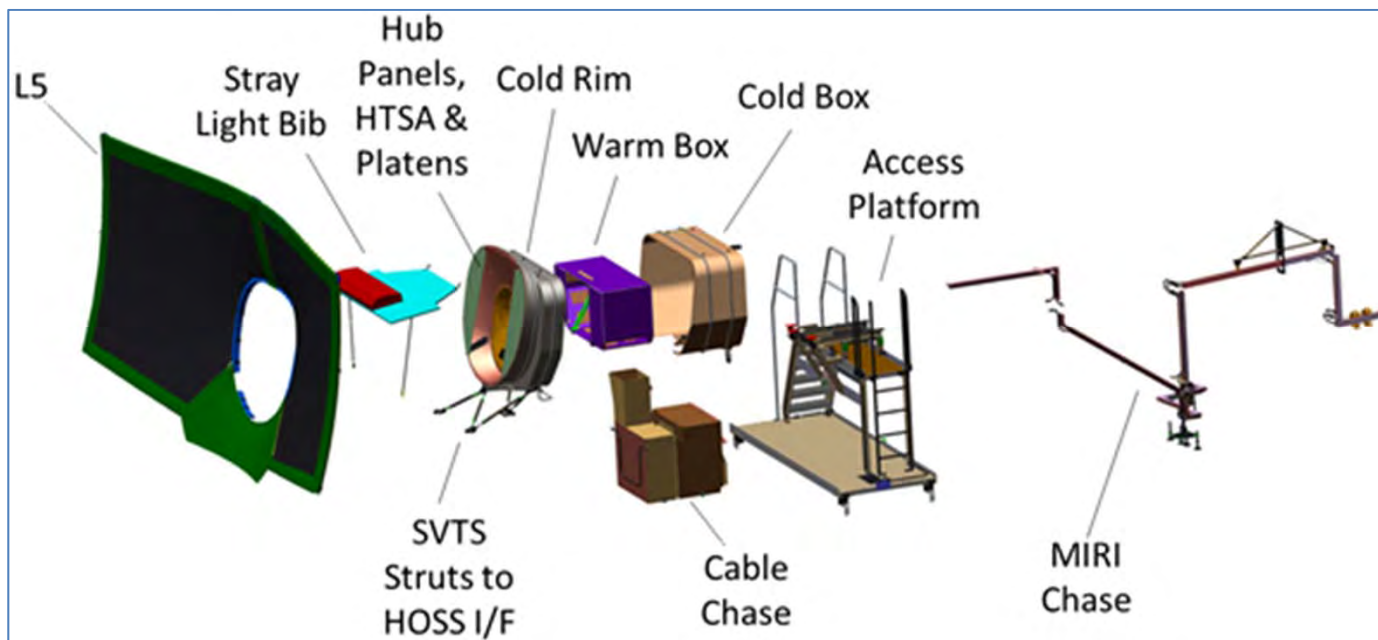

- SVTS hardware mounted on HOSS: HTSA, bib, platens, heaters, and L5

- SVTS hardware mounted on rails: warm and cold box, MIRI chase, and venting

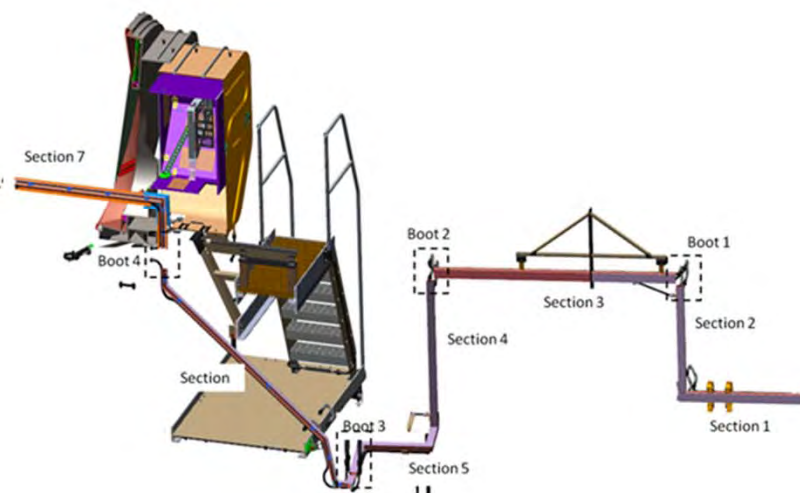
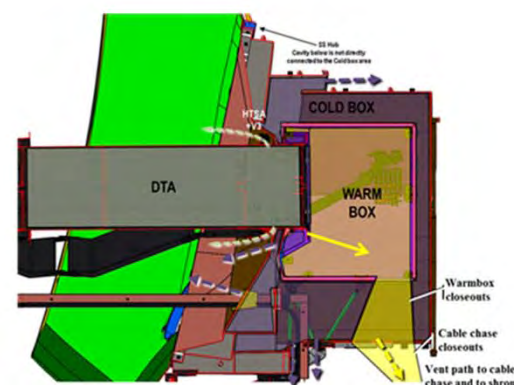
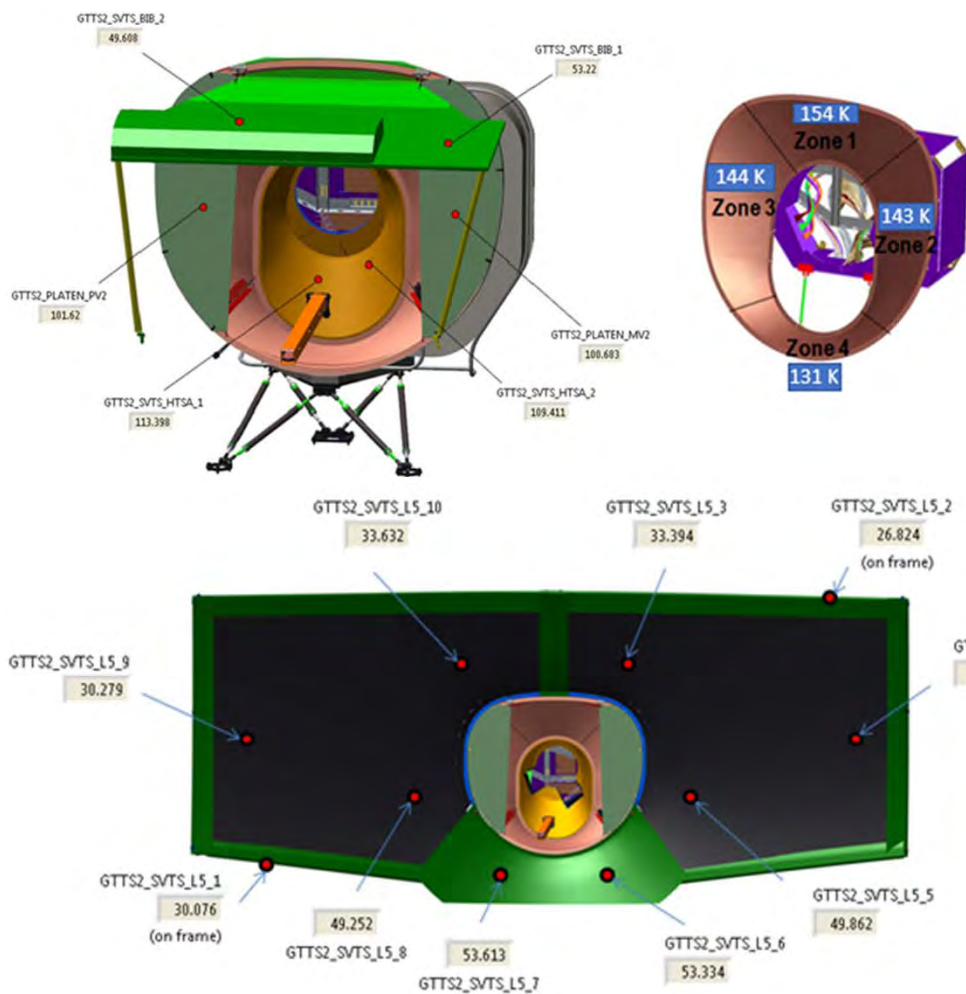



Telemetry and Test Controls: Test Sets

(ref ICES-2018-340)



- Harris was responsible for development of six thermal GSE test sets to control and monitor GSE subsystems as well as test-only OTIS sensors
- Thermometry included diodes, PRTs, Cernoxes and independent measurements with NASA-provided radiometers and calorimeters

6 Thermal GSE Test Sets



ACF: 149 Sensors, 6 Heaters
CoCOA: 81 Sensors, 26 heaters
PG: 64 Sensors, 12 heaters
ADMA: 19 Sensors, 3 heaters
TTS: 732 Sensors 22 Heaters
TTS2: 364 Sensors 108 Heaters
TTS&TTS2 Clone Computers (Redundant GUIs)

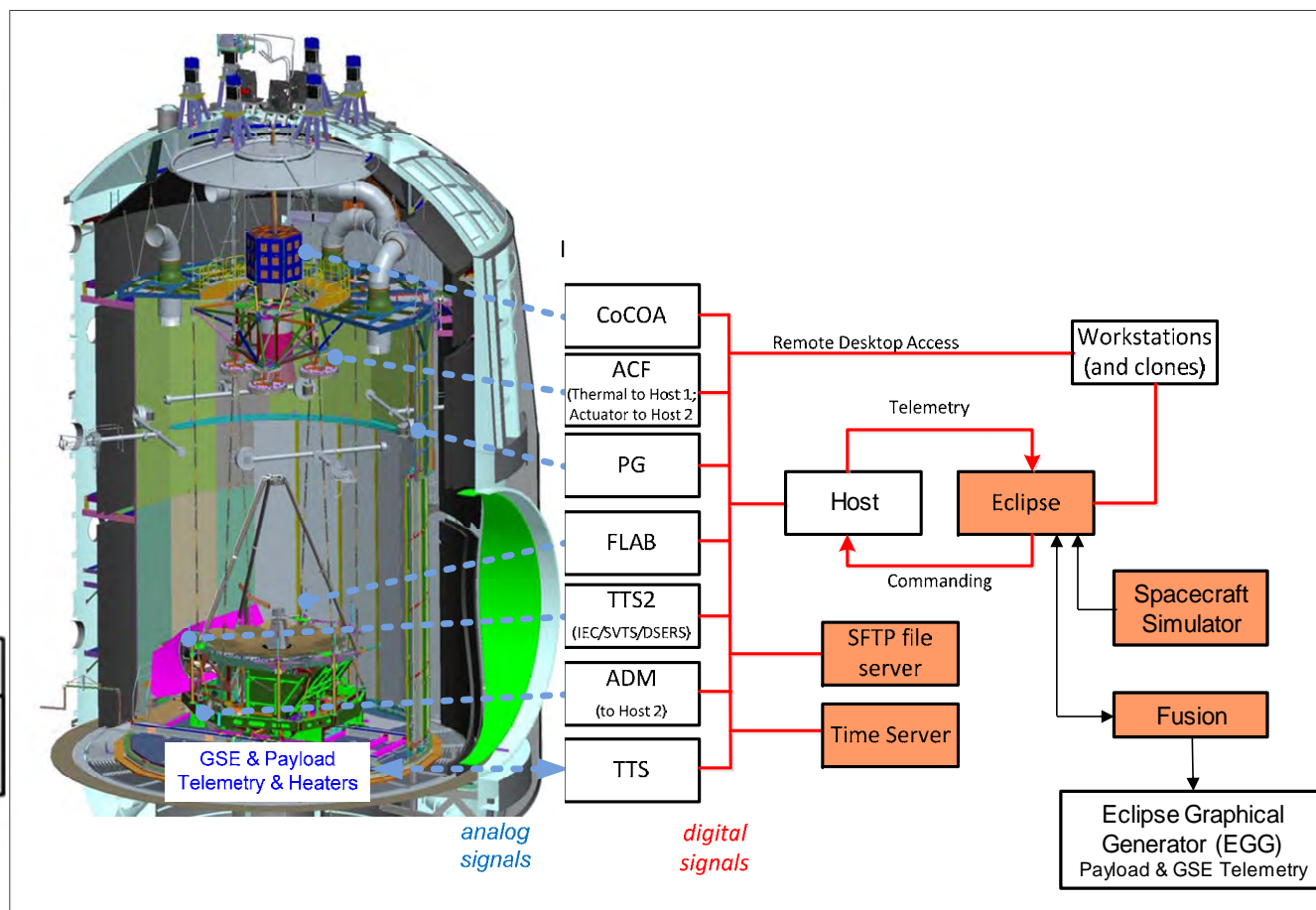



New Slide Sensor Accuracy



- The typical temperature sensor package used in Harris test sets were the Lakeshore DT670 diodes, with some Cernox sensors on pre-cool straps
- All sensors were calibrated and wired with a 4-wire phosphor-bronze configured with dual twisted pair leads
- Temperature accuracy is a combination of the calibration accuracy and the Lakeshore instrument accuracy
- Temperature resolution is a decade smaller for the test sets, although noise and other factors may limit clarity of readings

Note: all data is based on analysis of Lakeshore published instrument and sensor documentation

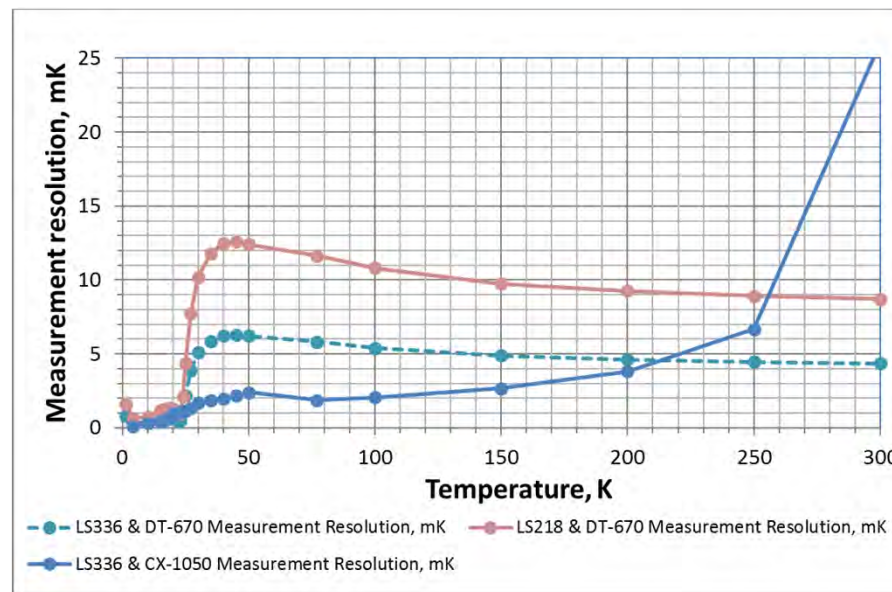
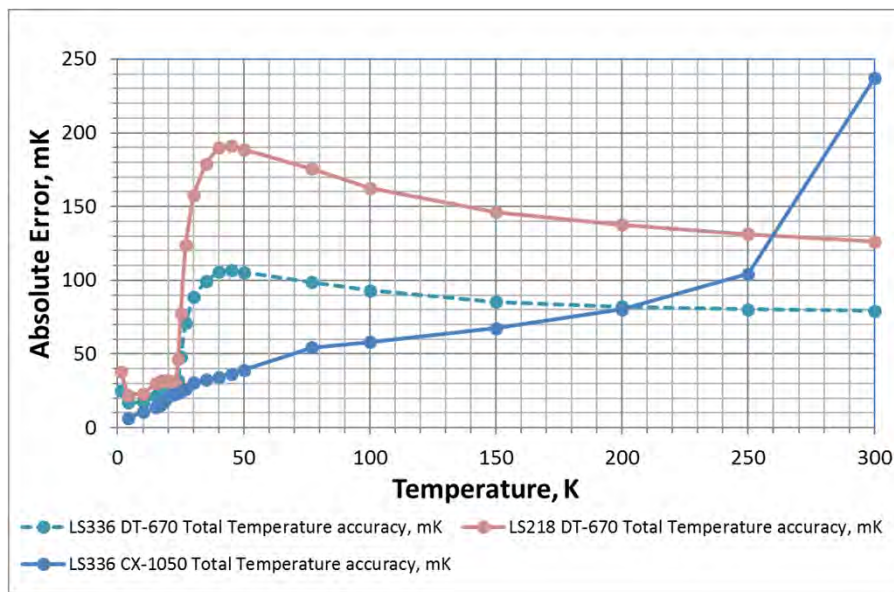



New Slide Pre-cool Strap Sensor Calibration



- During Thermal Pathfinder test, the pre-cool strap Cernox sensors were calibrated for relative uncertainty (how much they differ)
- Sensor pairs (i.e. on same structure) were compared to measured differences
- Data during the transient pressure spike (i.e. loss of compressor 1) excluded

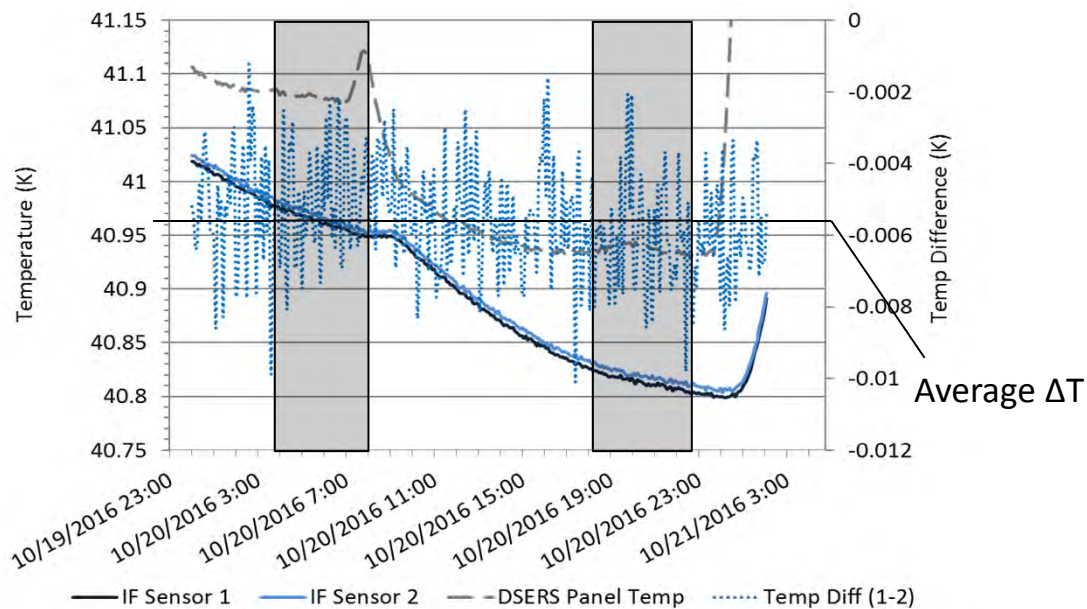

	Mean Difference (K)	Abs(Mean) + 3 Std Dev (K)
FGS IF	0.0154	0.0191
FGS 0-Q	0.0285	0.0322
FGS ISIM Sim	-0.0012	0.0090
MIRI IF	-0.0557	0.0598
MIRI 0-Q	0.0196	0.0238
MIRI ISIM Sim	-0.0064	0.0120
NIRCam 0-Q	-0.0119	0.0181
NIRCam JCT	-0.0019	0.0089
NIRCam ISIM Sim	-0.0017	0.0087
NIRSpec OA IF	-0.0097	0.0157
NIRSpec OA 0-Q	0.0037	0.0141
NIRSpec OA ISIM Sim	0.0201	0.0301
NIRSpec FPA IF	-0.0055	0.0104
NIRSpec FPA 0-Q	-0.0053	0.0142
NIRSpec FPA ISIM Sim	0.0120	0.0162

Relocating the best sensor pairs to be located at opposite ends of the strap, the calibrated relative uncertainty can be used. This yields up to 3.0 mW for heat leak



New slide Harris Thermal/Electrical GSE Design (TTS)



- Custom GUI & Control Software built in Labview
- Monitored and controlled GSE as well as flight clip-and-fly and test-and-remove sensors
- Provided real-time status of instruments & feedback against red & yellow limits
- Subsystem screens show sensor locations and provide heater control
- Capable of calculating temp-dependent limits, group avg/max/mins, delta between 2 sensors, and rates of calculations & individual sensors
- Customizable graphics

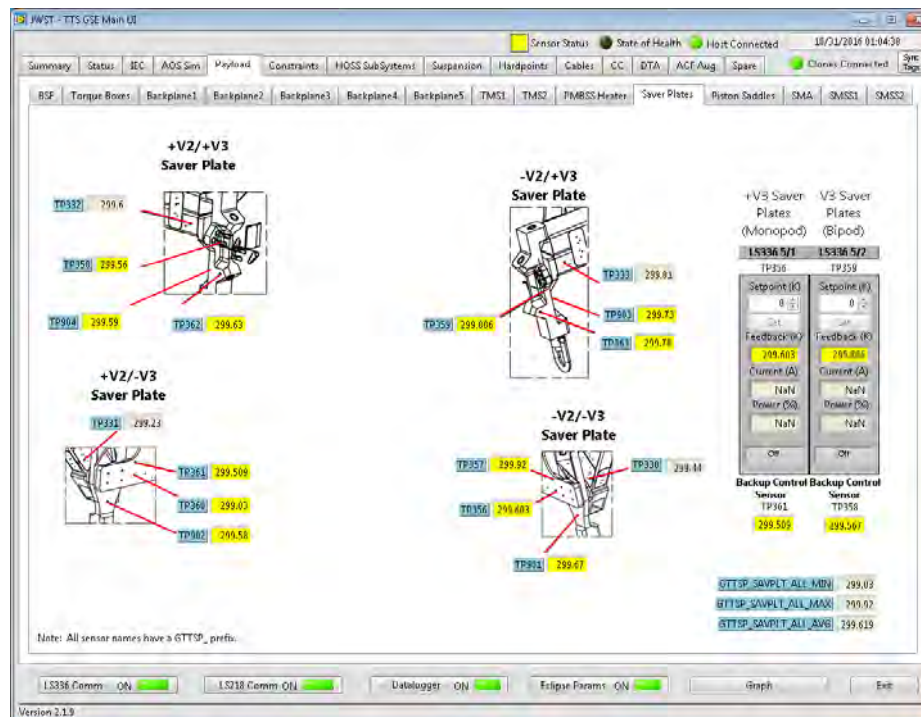
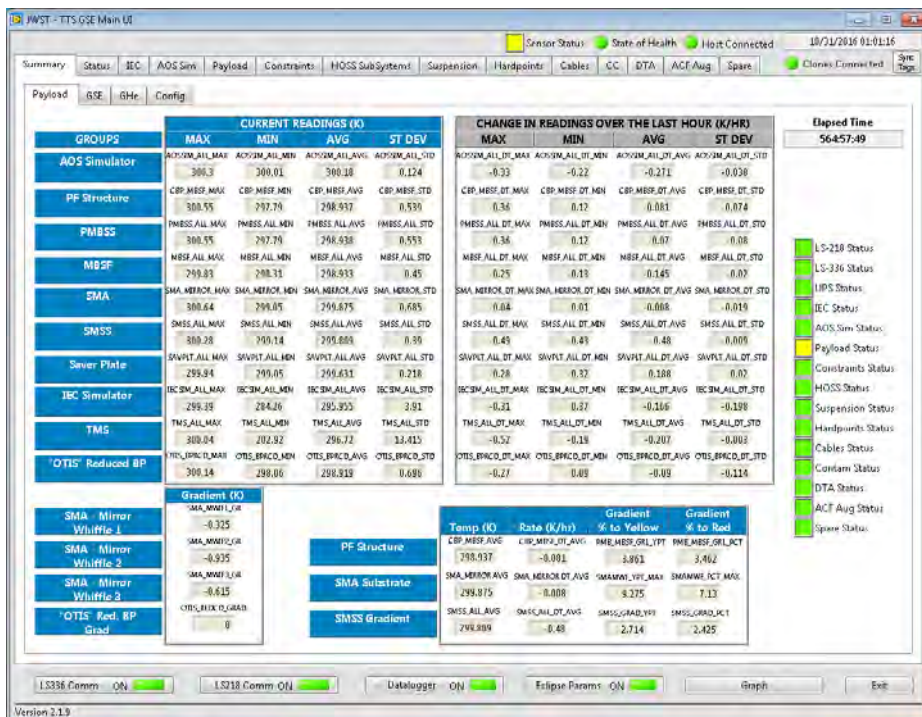



New slide TTS - Telemetry Pages



Summary/Overview Page

Test Set connection status

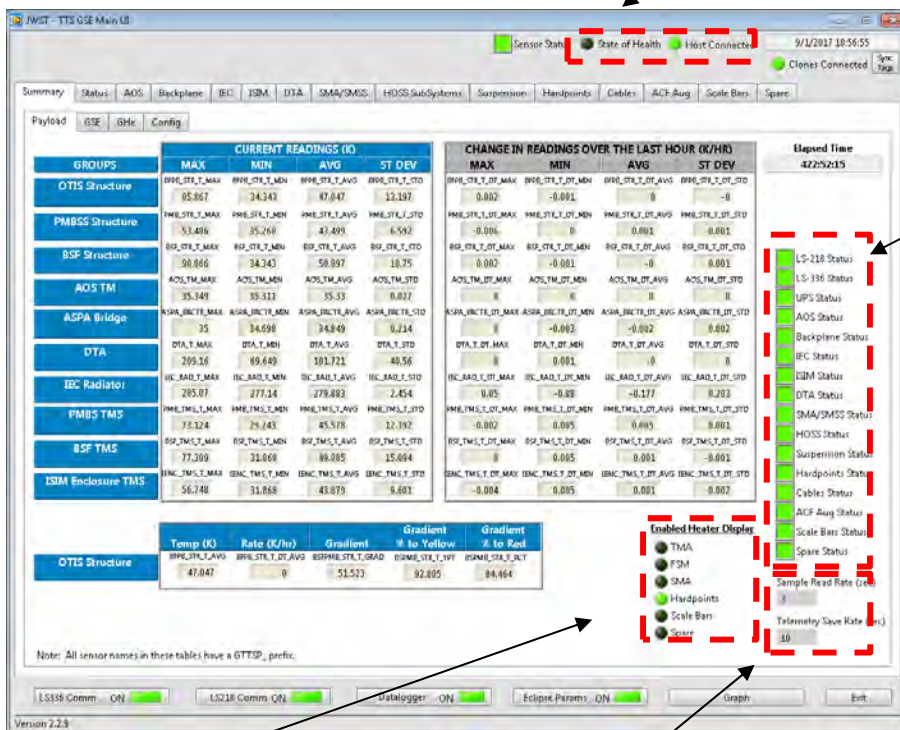

Subsystem Status

Graphical Subsystem Page

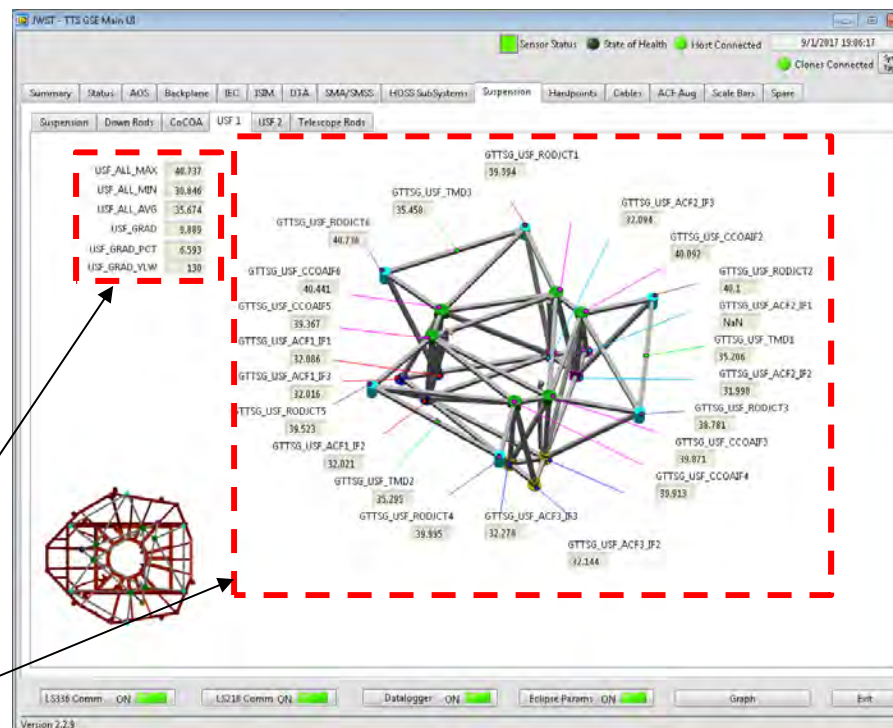

LEDs show which heaters are enabled

Sample read rate and telemetry save rates

Group Max, Min Avg

Sensor values with image



New slide TTS - Graphing Window



Display/hide series in graph

Edit scrolling interval up to 24 hours

Lock the time or temp scale for editing

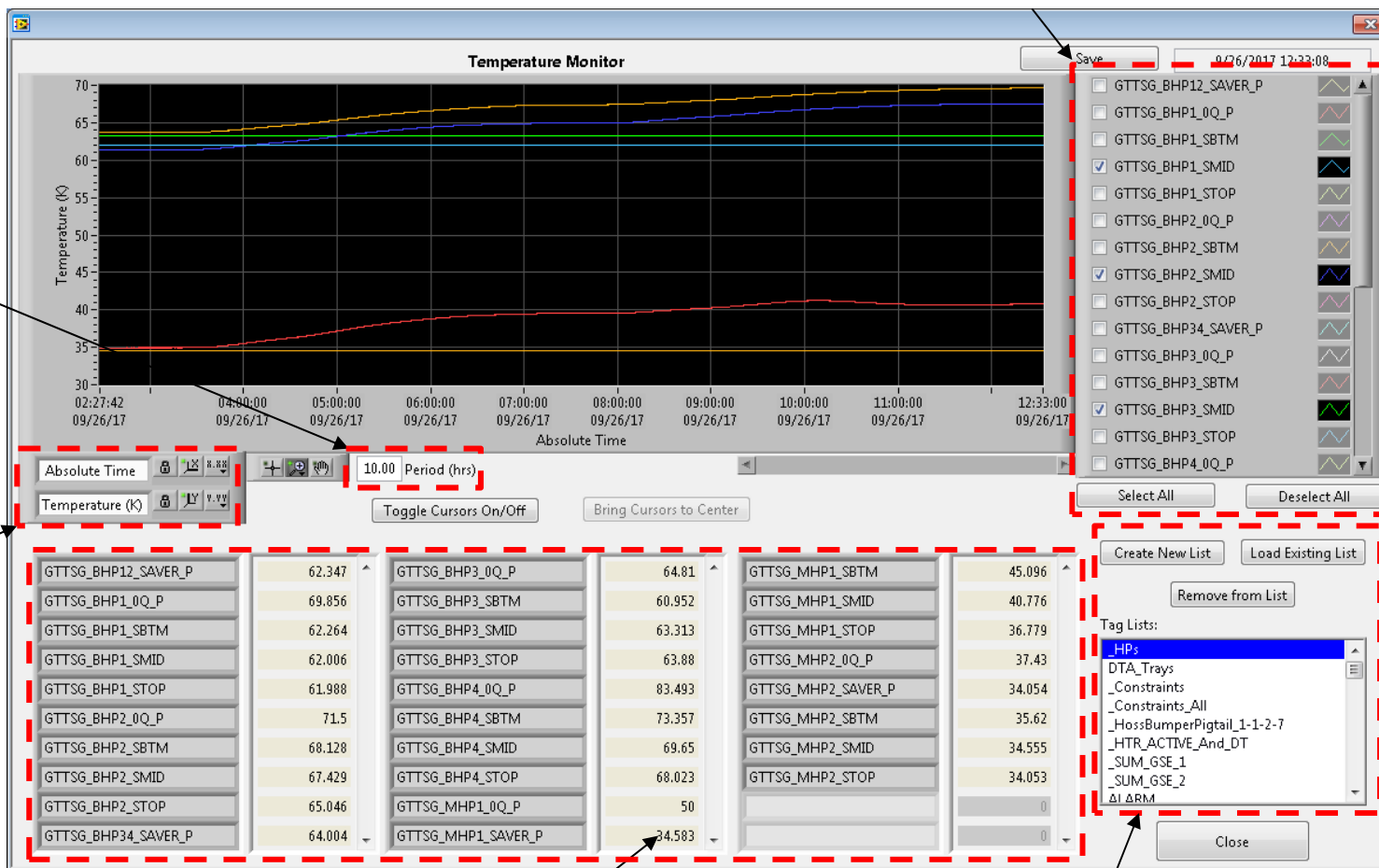

Current telemetry values displayed

Graph list selection (can add/edit/delete in real-time)



New Slide Eclipse Graphical Generator (EGG) Test Display Screen Example

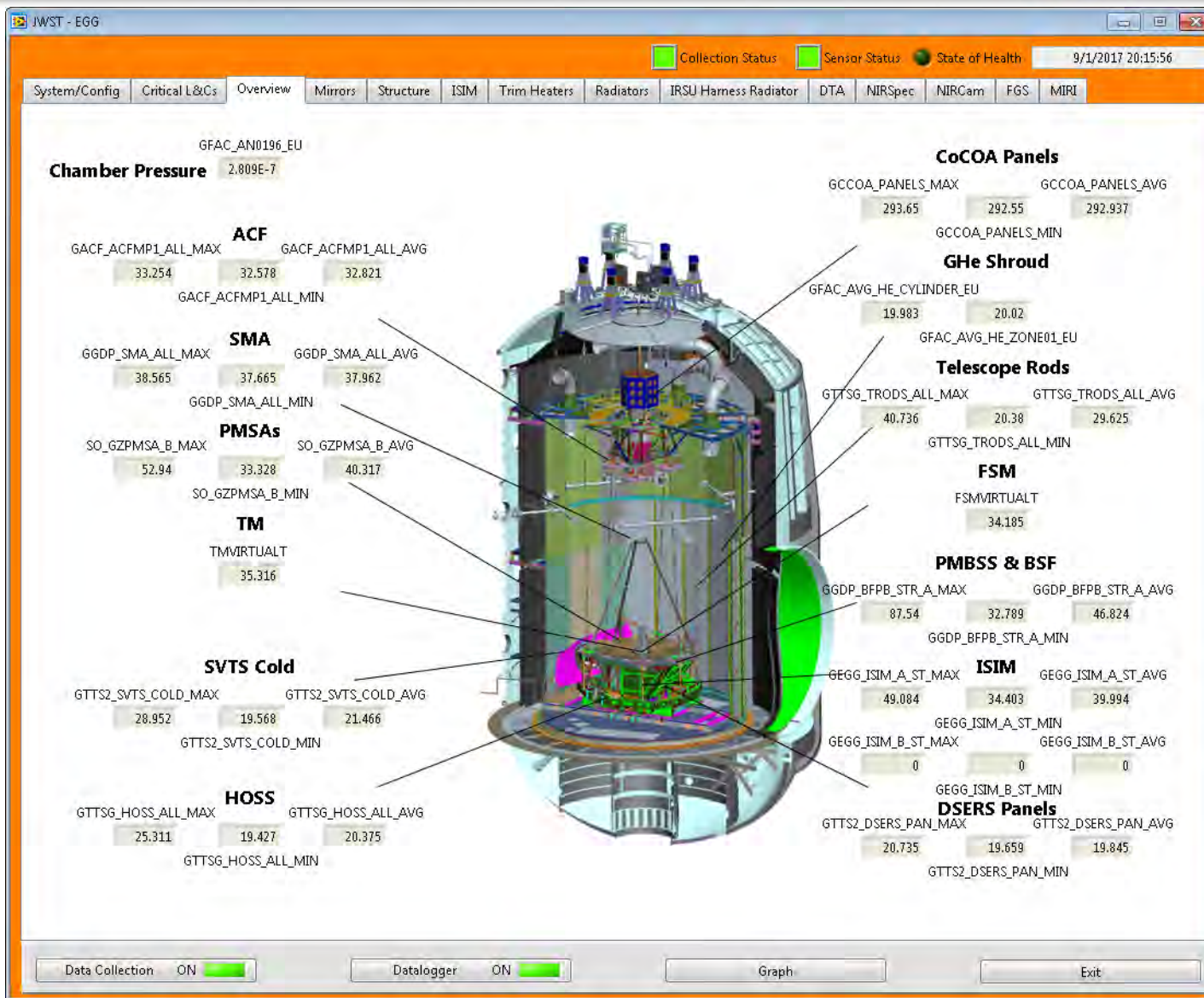



Thermal Control Overview – Managing Parasitic Heat Loads (ref ICES-2018-291)



- Thermal Control Objectives:
 - Eliminate direct view factors from the chamber wall into the GHe shroud.
 - Minimize direct view factors from the LN2 shroud into the GHe shroud.
 - Minimize reflective (non-black or specular) surface finishes in view of the optical path.
 - Achieve < 70 K on all surfaces within view of the optical path.
- Thermal Control Methods:
 - Shroud penetration closeouts
 - Stationary and movable
 - Thermal anchoring of electrical cables entering the shroud
 - Thermal control systems for test equipment operating inside the shroud

- Stray light from warm sources can saturate instruments and interfere with optical testing of science instruments

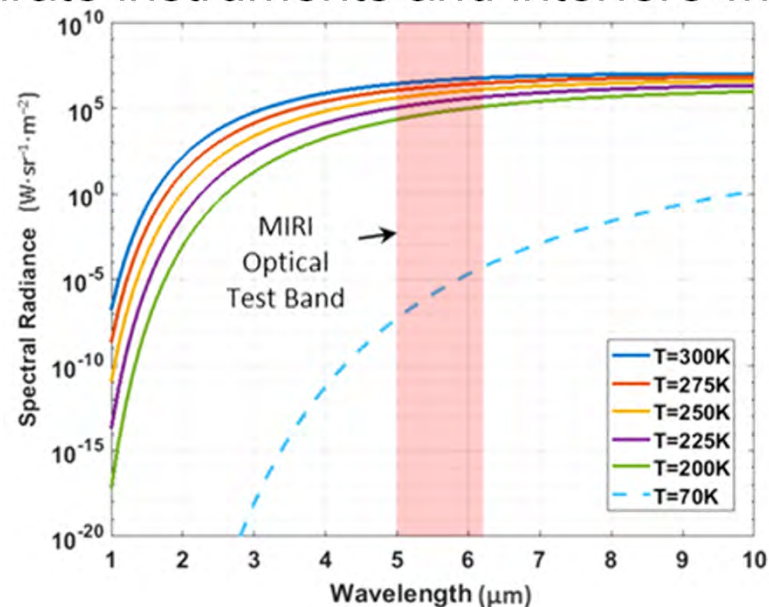
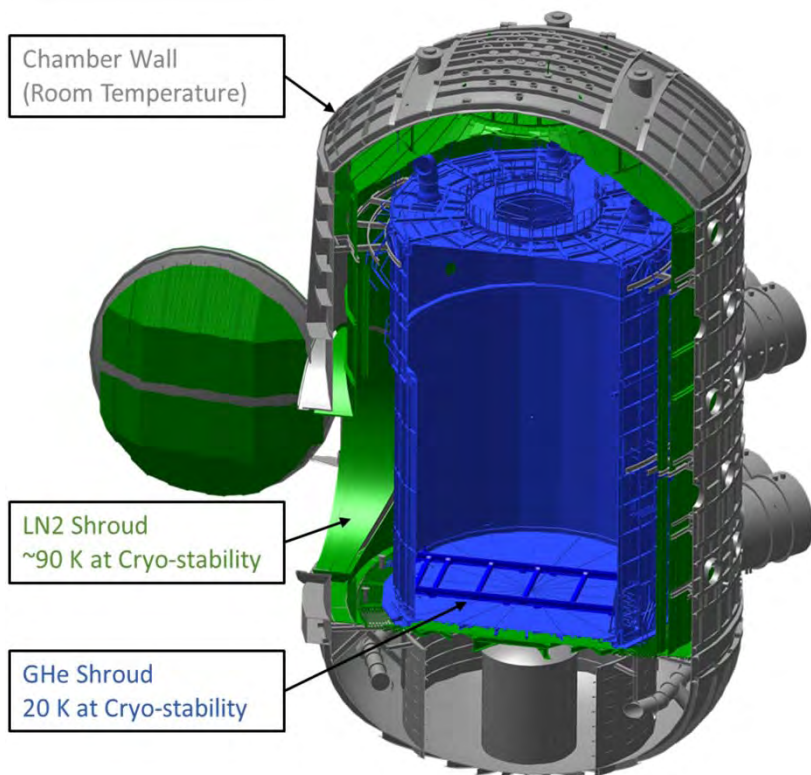

- A conservative maximum allowable temperature requirement of 70 K was levied on all surfaces with a view to the optical path
- All penetrations in the GHe shroud and all test equipment entering it required thermal management

- Top-mounted, hanging configuration of the OTIS test resulted in critical load-bearing hardware penetrating the shroud ceilings.
- Dynamic quiescence required that closeouts minimize shorts.
- A two-part system was used in this example:
 - Baffle mounted to rod and sized to prevent touching shroud was used to remove direct energy paths into test cavity
 - Flexible outer layer created light-tight seams

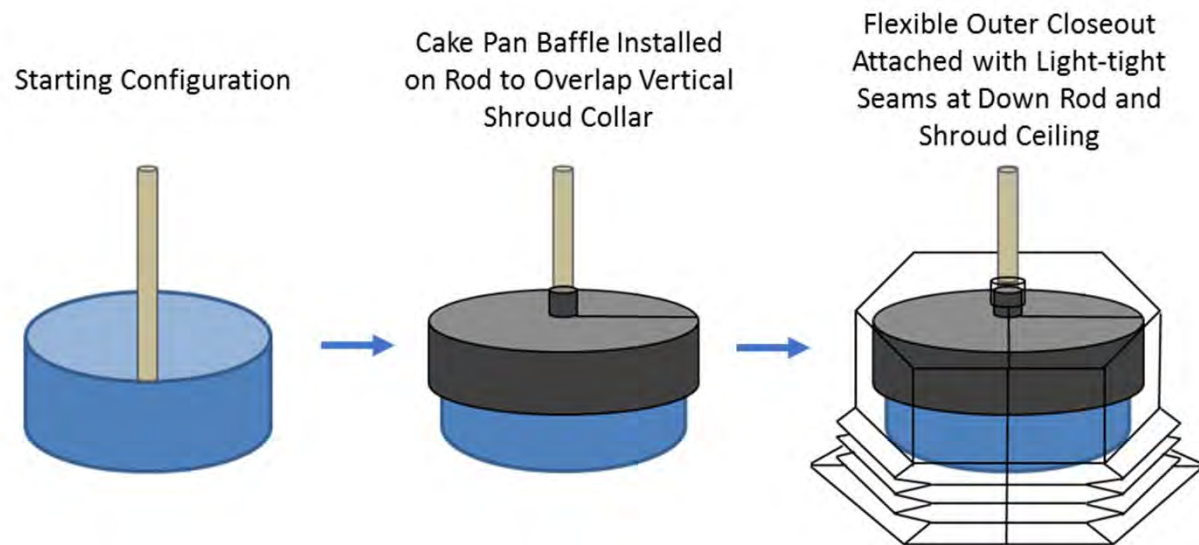

- Complicating factors of this closeout job:
 - Large shroud cutout – approximately 0.25 m²
 - 355 degree rotation requirement of the PG Boom
 - Had to survive at least 5 cryo-cycles
- Multi-part Baffle Solution:
 - Wire-stiffened SLI closeout attached to shroud necks down energy through-path.
 - Aluminum cake pan baffle attached to GHe-cooled PG Boom and overlapping SLI closeout eliminates direct viewfactors from LN₂ and chamber wall to SLI gap.
 - Aluminum internal baffle attached to GHe-cooled PG Boom completely blocks direct energy from cutout area and redirects energy back to shroud wall

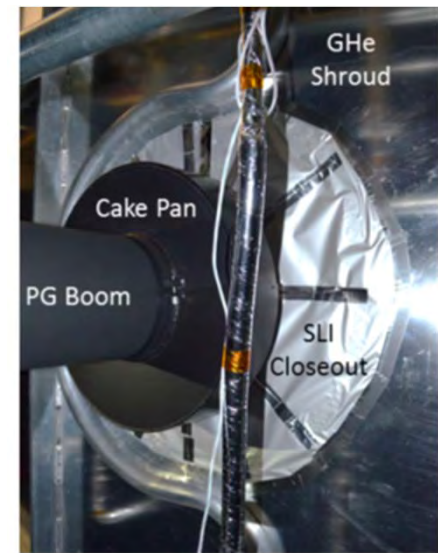
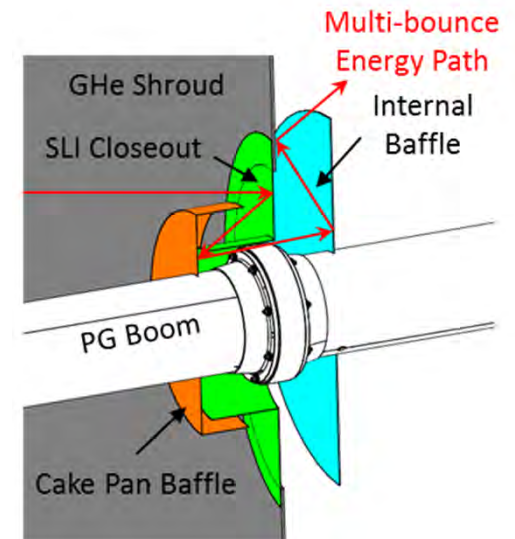

- Test telemetry and thermal control systems required dozens of cable bundles enter the optical test cavity.
 - 164 GSE Heaters
 - 964 GSE Sensors
- Thermal management was required to ensure cables entered the 20 K environment below the 70 K limit.

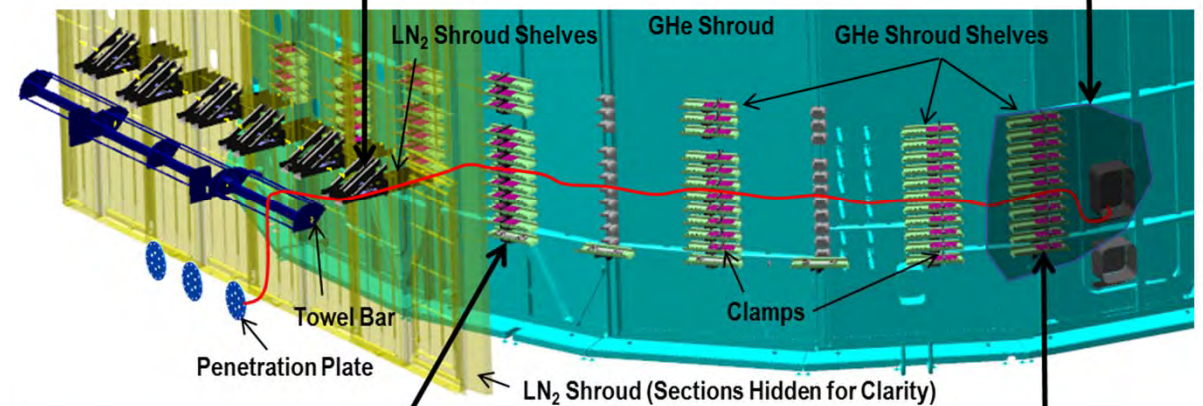
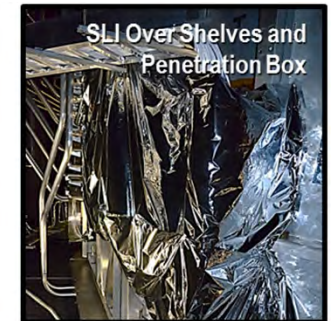

Harris System Thermal Model used for over a decade of test design/planning and GSE system design. Needed to:

- Predict GSE system profiles against L&Cs and test objectives.
- Run fast enough for in-test checks

Fully housed in Thermal Desktop includes:

- Temperature-dependent properties
- 1-way conductors modeling fluid flow

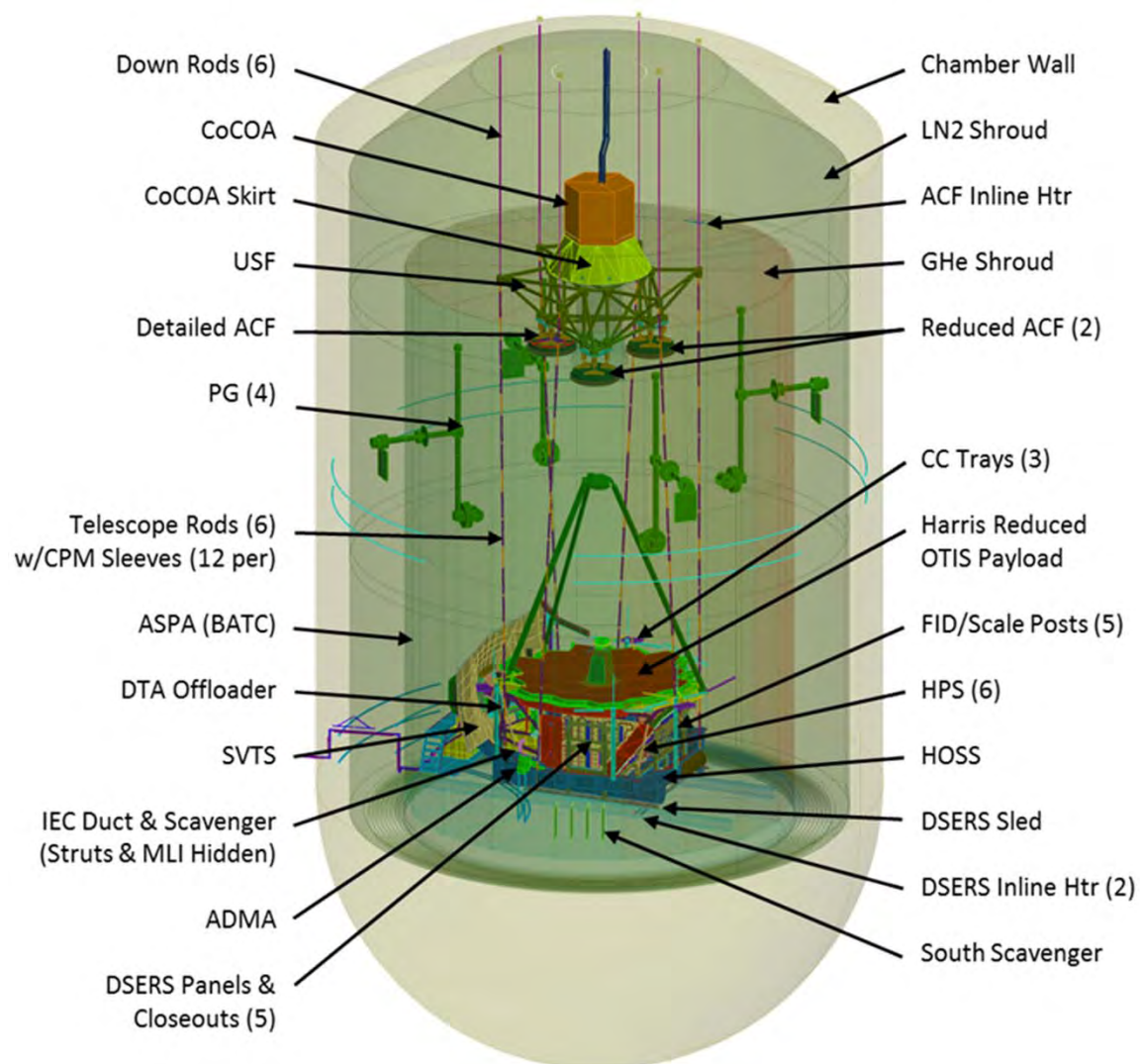



New Slide OTIS Reduced Payload Model



- Matched radiative properties on all external surfaces
- Matched geometry within reason
 - <5% surface area differences
- Matched MLI/SLI designations
 - From tech spec and TMS CDR documents to date

OTIS Observatory Model

Over 15000 External Radiation Nodes

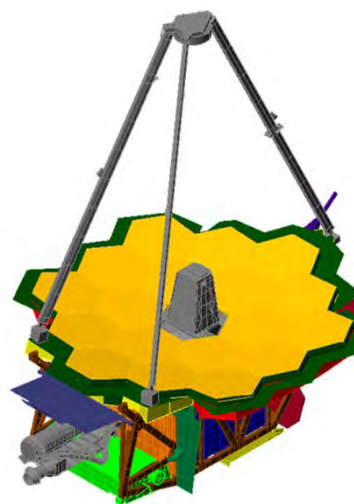

Harris Reduced OTIS Model

2531 Nodes Total

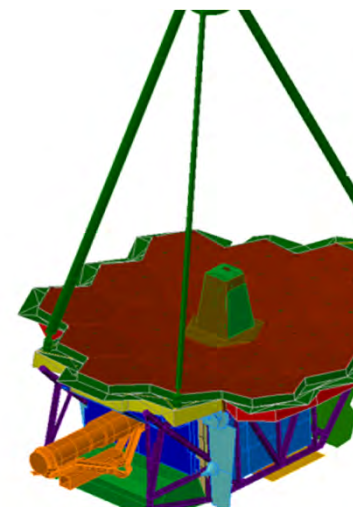

Models Match within 1.5% of total heat



New Slide Transient Test Cases



- Ambient-vac case added to correctly generate active cool down starting point
- Transient profiles broken up to allow adequate temp-dependent radiation recalcs
- Cryostability broken into 2 steady state cases:
 - Thermal Balance (shutter closed)
 - SSCryo (shutter open) for start of Warm Up map

Case Name	Model Start Time Seconds (Days)	Model End Time Seconds (Days)
OTIS_Amb_Vac	-604800 (-7)	0.0 (0)
OTIS_Cooldown1	0.0 (0)	518400 (6)
OTIS_Cooldown2	518400 (6)	1296000 (15)
OTIS_Cooldown3	1296000 (15)	1900800 (22)
OTIS_Cooldown4	1900800 (22)	2592000 (30)
OTIS_Cooldown5	2592000 (30)	3283200 (38)
OTIS_TB	5439600 (62.9583)	N/A
OTIS_SSCryo	5954760 (68.9208)	N/A
OTIS_Warmup1	5975520 (69.1611)	6537120 (75.6611)
OTIS_Warmup2	6537120 (75.6611)	6839520 (79.1611)
OTIS_Warmup3	6839520 (79.1611)	8221920 (95.1611)

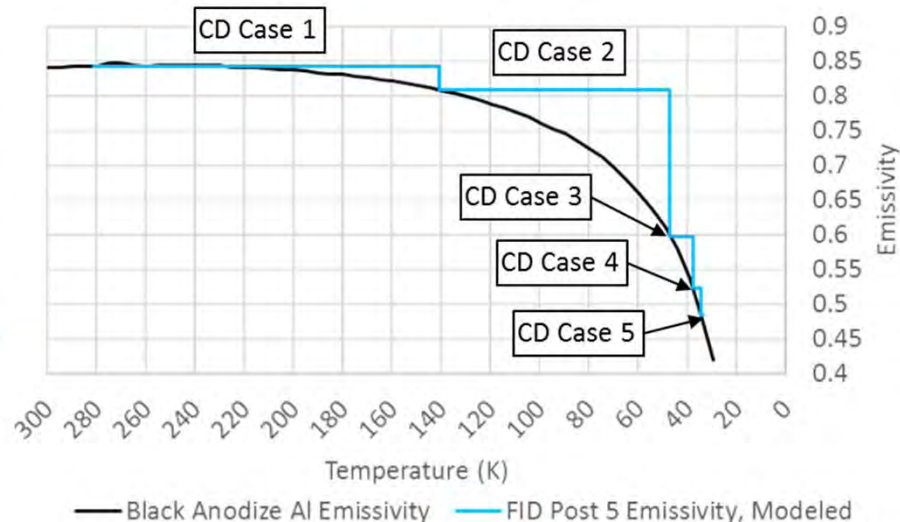
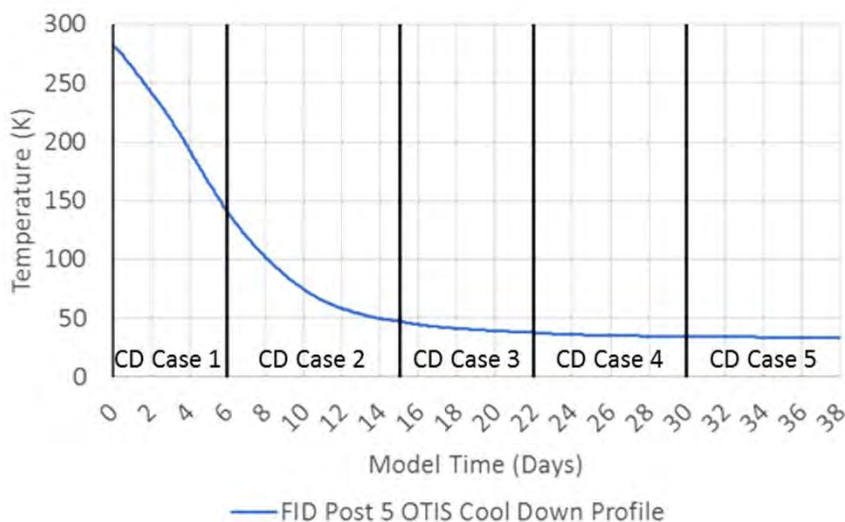



New Slide Model Fitness



- Basic question: How good are the uncorrelated model predictions?
- Answer by comparing node/sensor pairs for each subsystem in two regimes:
 - At Thermal Balance
 - Over Transient Profiles
- MATLAB test data processing routine developed with added feature of importing Thermal Desktop results & a node/sensor lookup to generate individual pair comparisons, subsystem summaries, and full model summary

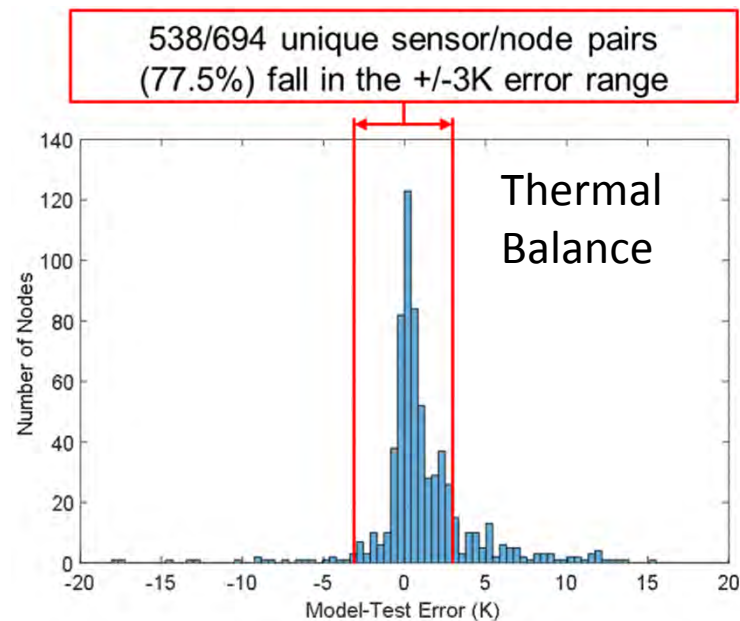
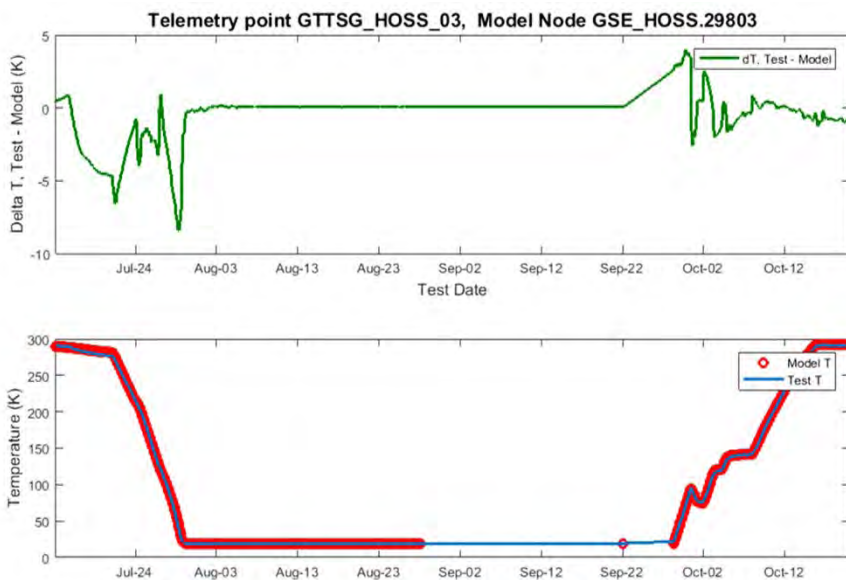



Summary (ref ICES-2018-340)



- The OTIS cryo-vacuum test required the development of an extensive suite of optical, mechanical, and thermal GSE subsystems and devices
- The designs and test campaign required attention to every detail due to the large size of the payload and the challenging cryogenic test environment
 - Thermal systems successfully measured milli-Kelvin temperature and milliwatt heat flows
 - Optical systems measured nanometers of displacements while the hardware moved 5 cm
 - Large mechanical structures safely carried 27,000 kg while keeping the flight payload safe and dynamically stable



Acknowledgments (ref ICES-2018-340)



- JWST is a collaborative effort involving NASA, industry partners, the European Space Agency, the Canadian Space Agency, the astronomy community and numerous principal investigators
- OTIS cryo-vacuum test GSE hardware design, integration, and execution was carried out under the JWST contracts NNG11FD64C with NASA's Goddard Space Flight Center and NNG15CR64C with ATA Aerospace
- Special thanks to:
 - The entire Harris thermal team
 - The Harris mechanical and electrical teams and assembly crew who implemented our thermal designs into hardware systems with great attention to detail
 - The entire JWST thermal community and their exceptional technical skills, professionalism, and dedication in all situations over many years



new slide 2017 OTIS Cryovac Test Harris Thermal / Electrical Team



OTIS After Test – Still in Great Shape!



Control Room at Shift Change

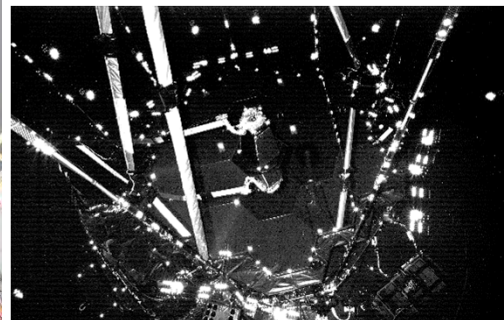

OTIS at 70K as seen by PG System



Thermal Station EGG, ADMA, PG, COCOA, ACF, TTS2, TTS, DARAC (JSC)



Garry Fink, Matt Callahan, Jim Lawton, Danielle Williams, Jesse Huguet



Add Keith Havey, Tom Stockton, Liz Daly, Dwight Cooke



Add Bob Day, Clint Travis



Add Mike Commons, Perry Pesce



Add Rob Page

Not shown Chris Sullivan, Perry Voyer, Dean Freeberg, Mark Connolly



New Slide Lessons Learned





New slide Lessons Learned: Preparation



- Develop a test plan that burns down risk rigorously.
 - The JWST cryovac development testing program and the demonstration of successful operation of all GSE metrology systems prior to the final flight test was a huge risk reduction for OTIS
 - Early identification of test challenges provided time to implement solutions.
- Train your team!
 - Be sure all expectations of what to monitor and what to record while on shift are captured in writing.
 - The OTIS test was a big success due to the expanded training regiment for OGSE as well as for flight hardware teams.
 - In a land far away ... working offsite has additional challenges
- Define test management rules when hardware is near red & yellow limits.
 - JWST test team had multiple interpretations of how to react early on
 - Definition and consistent interpretation is needed early in the test planning phase.



New slide Lessons Learned: Scope of Telemetry Needed



- Develop a robust thermal instrumentation plan – multiple thermometry systems may be needed to rigorously interpret test results in a cryo test.
 - Extensive effort was spent to insure the calibrated diodes and Lakeshore units would provide the desired accuracy and resolution.
 - This was complimented with radiometers that could measure localized heat sources to high sensitivity.
 - This was further complimented with calorimeters that were simple and independent of mounting technique for understanding radiative boundaries and icing.
 - JWST would have benefited from a more robust GHE flow calibration - model results would have been much easier to compare to test data if accurately measured flow rates were available.
- Critical sensors need to be mechanically secured in a cryo test.
 - Sensors held well over ~95% of time with thermal tape, but adhesion was workmanship and substrate dependent.
 - If a sensor is critical then be sure that at least representative locations are secured more robustly.



New slide Lessons Learned: Combined Loads & Thermal Strain



- Be sure you have enough sensors to evaluate thermal stresses.
 - During cryoload test we had insufficient sensors to easily assess stresses in low conduction stainless steel structures with large gradients.
 - Also confirm that the form factor of the gradients between test and analysis agree – largest gradient is not necessarily the largest stress
 - We needed to rely on extensive thermal model simulations to interpolate and extrapolate readings both for USF and for HOSS.
 - HOSS had the added uncertainty of inadequate flow rate data

- Define test Limitations & Constraints based on measurable data
 - Sensor locations should correlate with limits
 - Uncertainty factors are required if sensors do not capture peak stresses

- If there is a problem in test do you have a method to control gradients?
 - In our case GHE flow rate and shroud cooling were the primary tools for some hardware.
 - ACF and DSERS also had heater control



New slide Lessons Learned: Preparing for Fast Temperature Response to Low Mass or High Power



- In cryo test conditions, a runaway heater can have devastating consequences.
 - Insure that adequate controls are in place between temperature monitoring system, max heat settings, or software to address the risk.
 - Train your team on what to monitor, especially if automated methods are not possible.
 - Plan an instrumentation design capability which will reduce maximum available power as a function of temperature.
 - For OTIS, this LL was applied and all critical heaters had current and ramping rate limits imposed.

- In a cryo test, be sure that all heat sources are modeled sufficiently to determine instrumentation needs.
 - OTIS Frill and SVTS Bib are good examples – perhaps more modeling of shutter effects would have resulted in more sensors in key locations.



New Slide Lessons Learned: PID Control



- Now that we've got this great thermal system

- If you utilize PID control, plan sufficient time to develop control parameters, or take test time to tune up the controllers.
 - There were not many opportunities during test where we could tune parameters without impacting some other test event.
 - PID control requires significant analysis time or dedicated test events
 - For example, the CoCOA thermal enclosure was hard to tune because the panels were so radiatively coupled.



New Slide Lessons Learned: Flexibility to deal with Constraints



- Plan in detail the implementation of contamination constraints on test operations.
 - Contamination constraints are complex in a system that needs to cool through water transition bands down below 120K.
 - Develop procedures with all subject matter experts running the test, and be sure all are trained.
 - Clearly define where there is flexibility in the constraints.

- Plan for high gas load contingencies (modeling, analysis, design).
 - Gas heat transfer due to GHe backfill and also due to chamber / COCOA air leak had major ramifications for thermal management of ADMA and PG.
 - PG and ADMA purge gas heating systems were upgraded to accommodate the thermal shorts at higher pressures.
 - Gas backfill can be (and was!) successfully used to accelerate transient profiles, but precisely modeling the response of complex geometries is a developing art.



New Slide Lessons Learned: Modeling



- Though model correlation wasn't required, tuning the subsystem models through 5 years of development tests resulted in an adequately accurate model that was fast enough for in-test runs.
- Model fidelity should be driven by the objective of the cases being run.
 - Reduced thermal models can save enough computation time to justify their creation and can be critical to making analysis timelines meet schedule requirements.
- Parametric trades of radiation case set controls, FMHT modeling, and convergence criteria can help an analyst decide where computation time is best spent in terms of accuracy.



New slide Lessons Learned: Wrap-up



- Post test data review and analysis confirmed that GSE systems worked well leading up to and during the OTIS cryovac test.
- GSE instrumentation systems all worked well in test.
 - Cryovac development test program provided crucial opportunities to find/fix bugs and add useful capabilities.
 - The EGG tool was a great use of the clones to follow the full test system.
- Test preparation in documents, procedures, emergency planning, and training paid off well with OTIS.
- Thanks for all the support the last few years!



OTIS Exiting JSC Chamber A after Three Months of Testing

(ref ICES-2018-340)

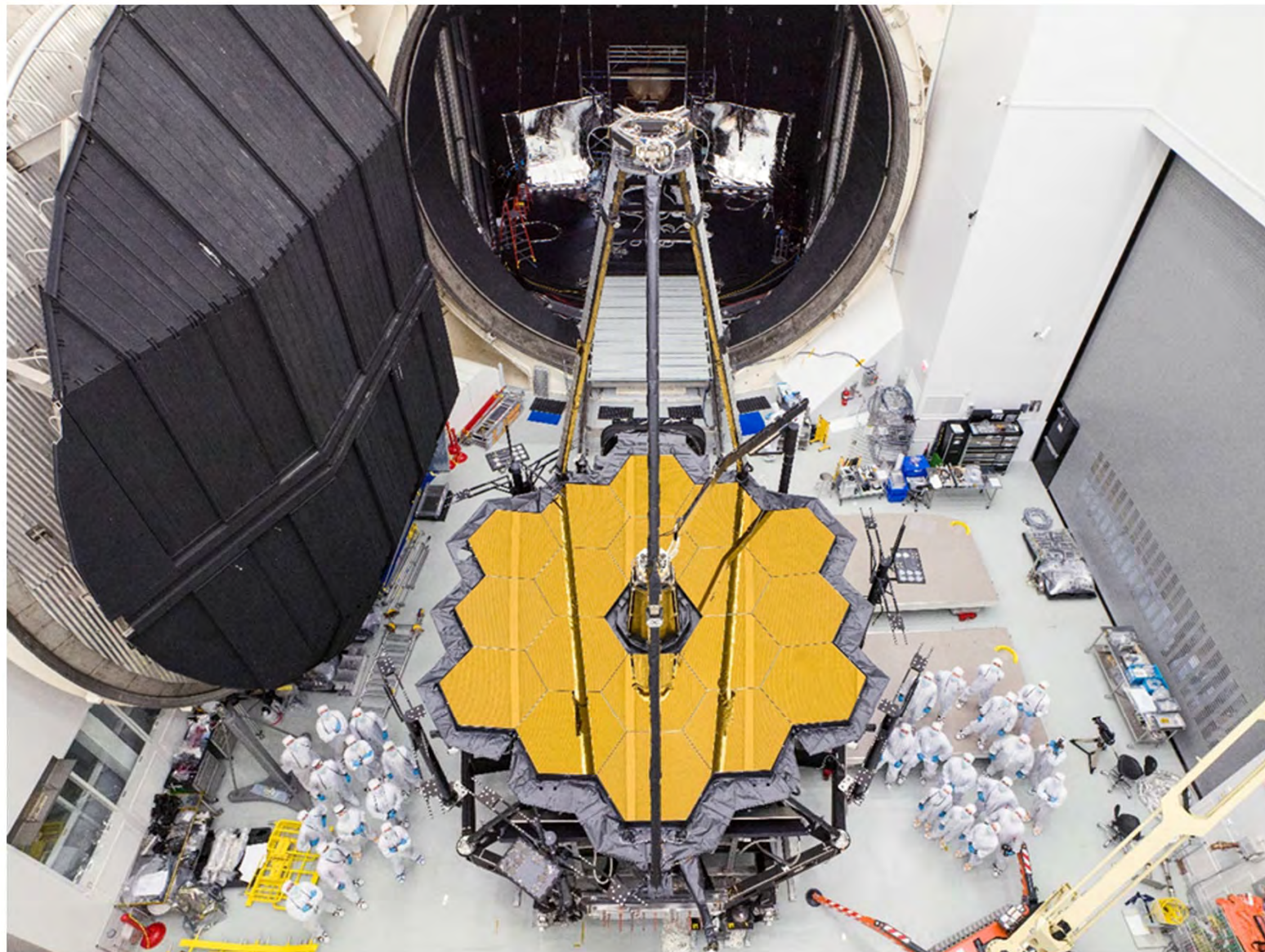
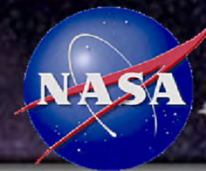

8/11/2018

TFAWS 2018 – August 20-24, 2018

52