

Toughness Testing for Liquid Hydrogen And Helium Temperatures

Validation of Austenitic Stainless Steels for 4K (-452F) Use

September 17, 2018

Owen R. Greulich, P.E., Office of Safety and Mission Assurance, NASA Headquarters, owen.greulich@nasa.gov

Dennis M. Lambert, Ph.D., P.E., Damage Tolerance Assessment, NASA MSFC, dennis.lambert@nasa.gov

Xiaoli (Shelly) Tang, Ph.D., Swagelok Company, Solon, Ohio, shelly.tang@Swagelok.com

Selin Sahici, PMP, Project Manager, ASME ST-LLC, SahiciS@asme.org

Outline

- Background
- Challenges
- PTCS Proposal
- Project Scope
- Testing Completed and Planned
- Possible Outcomes
- Representative Systems
- Charpy and Toughness Results
- Critical Crack Size
- Test Significance
- Project Cost to Date
- Testing Details
- Funding Needs
- Testing Details
- Backup Slides

Background

- Existing Code requirement: Charpy impact test at a temperature **no** higher than the design minimum temperature.
- Current Practice: Not clear
 - Indications are that testing is sometimes performed at -320F (liquid nitrogen or “LN2”) for that and all lower temperatures.
 - In some cases testing is probably not performed.
 - CGA indicated successful operation of systems at -453F without required test.
- Ballot activity: C & S Connect Record 13-341, Ballot 13-1746, initially proposed Charpy testing (lateral expansion criteria) at -320F to validate use at -452F (liquid helium or “LHe”)
- PTCS Proposal

Challenges

- Rapid adiabatic heating of test samples during Charpy impact testing at ultra-low temperatures makes current Charpy testing requirement invalid for ensuring material toughness .
- Any sort of testing in liquid helium is difficult to accomplish, expensive, and not readily available.
- Testing in LN2 has not been demonstrated to shed light on properties at -452F.
- Material **behaviors** are different at -452F than at higher temperatures (sawtooth stress strain curve, for example).

PTCS Proposal 9/15/15

- Scope and Objectives: This project will study the feasibility of performing toughness testing of austenitic stainless steels at a temperature of -320F as a means of validating them for use at a temperature of -452F.
- Technology to be addressed: Use of austenitic stainless steels for liquid hydrogen and liquid helium piping and pressure vessels.
- Code or standard impacted: materials testing in lieu of current testing in B31.3, B31.12, and Section VIII, Division 1.
- Methods/approach to complete project: Representative materials samples will be selected in sufficient range of chemical content (including tramp elements) and delta ferrite for both parent and weld material. Testing will be performed at both -320F and -452F, and possibly at intermediate temperatures. Correlations of results will be performed to determine whether testing at -320F is statistically justifiable for -452F operations.
- Results will be assembled and presented in one or more papers to be published.

Project Scope

Perform material testing to validate an approach to ensure suitable performance of austenitic stainless steel at -452F.

Tests Completed and Planned

ID	Material	Specimen mach. and prep. (precrack and side groove)	-452F Tensile Testing	-452F Fracture Testing	-320F Tensile Testing	-320F Charpy Testing	-320F Fracture Testing	-452F Fracture Test spares	Tensile Test spares	Report	Invoice
W1	316L	21	4	5	4	5	5	0	0	x	x
W2	316L	22	4	6	4	5	4	0	0	x	x
P1	316L	23	4	5	4	5	4	0	0	x	x
P2	316L	25	2	6	4	5	5	1	2		
P3	304L	25	2	5	3	5	5	3	2		
Completed											
In-Work											
Planned											
Spares											

- At this point, two welds and one plate of 316L stainless steel have been tested
 - at -320F: tensile, Charpy, and fracture
 - At -452F: tensile and fracture
- Additional testing is in process to complete testing of a second plate of 316L stainless steel and a plate of 304L stainless.
- Planned tests match those from earlier.

Possible Outcomes

The following represent the possible outcomes of this test and analysis effort. These were identified prior to testing.

1. Ideal: Material is demonstrated so robust as not to require toughness testing.
2. Correlation between -320F Charpy and -452F toughness properties is demonstrated, allowing LN2 Charpy testing for LHe operation.
3. No correlation demonstrated with Charpy testing, but correlation demonstrated between -320F toughness and -452F toughness.
4. No correlation between -320F and -452F properties, requiring testing at -452F.
5. Reduced allowable stress allows elimination of testing requirement.

Representative Systems

- CGA submitted a letter to the B31.3 Committee expressing concern with the idea of testing material at ultra-low temperatures, and included with that letter a list of 77 examples of 304 and 304L piping systems that have operated successfully in the range of -425F (liquid hydrogen or “LH2”) to -452F. 72 of these included sufficient data to calculate vessel membrane stress.
- This is a significant number of samples demonstrating successful operation and should be considered in assessing the capability of the material.
- Mean hoop stress in these systems was 1860 psi, a factor of ten below the material allowable stress. Many of the systems were operated with stress in the hundreds of psi. Six of the systems had stress greater than 5000 psi, and all were below 10,000 psi. (Note: Longitudinal stress would generally govern in circumferential pipe welds, and is half the hoop stress.)
- If material toughness is insufficient or is not easily demonstrated by testing at LN2 temperatures, a reduction in allowable stress for these temperatures might provide a workable solution.

Charpy and Toughness Results – Mean Values

Identity	FN	-320F Charpy, lateral expansion, in*10³	-320F KJlc, ksi-sqrt(in)	-452F KJlc, ksi-sqrt(in)
316L Weld, W1	3.5	42	266.7	178.6
316L Weld, W2	5	36	260.6	147.1
316L Plate, P1	1.2	90	390.6	227.8
316L Plate, P2	0			224.9
304L Plate, P3	not tested yet	78		

Toughness versus Temperature

Fracture Toughness versus Temperature--316L Plate

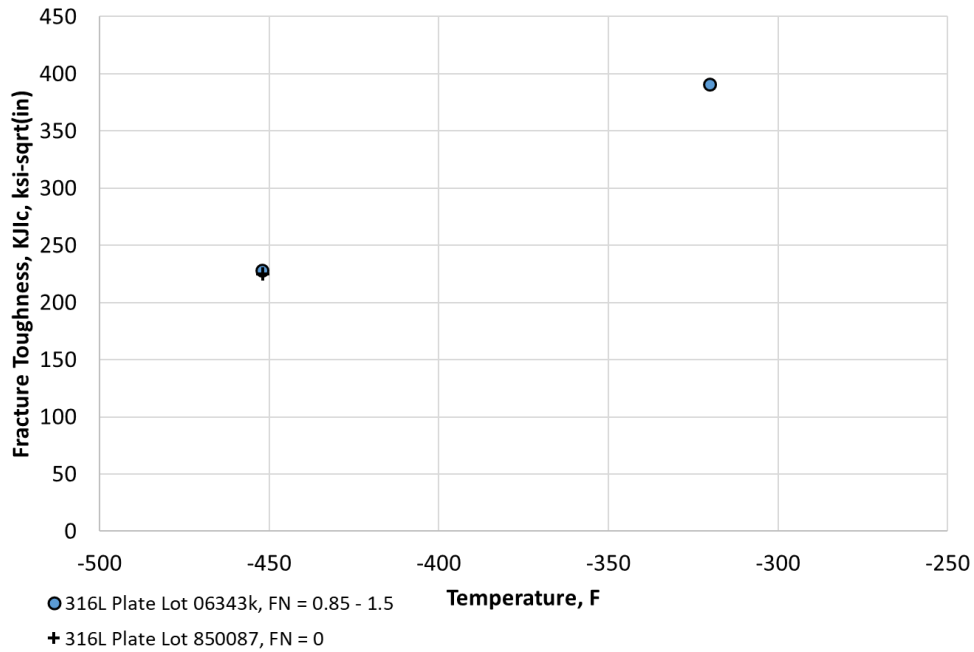

Fracture Toughness versus Temperature--316L Welds

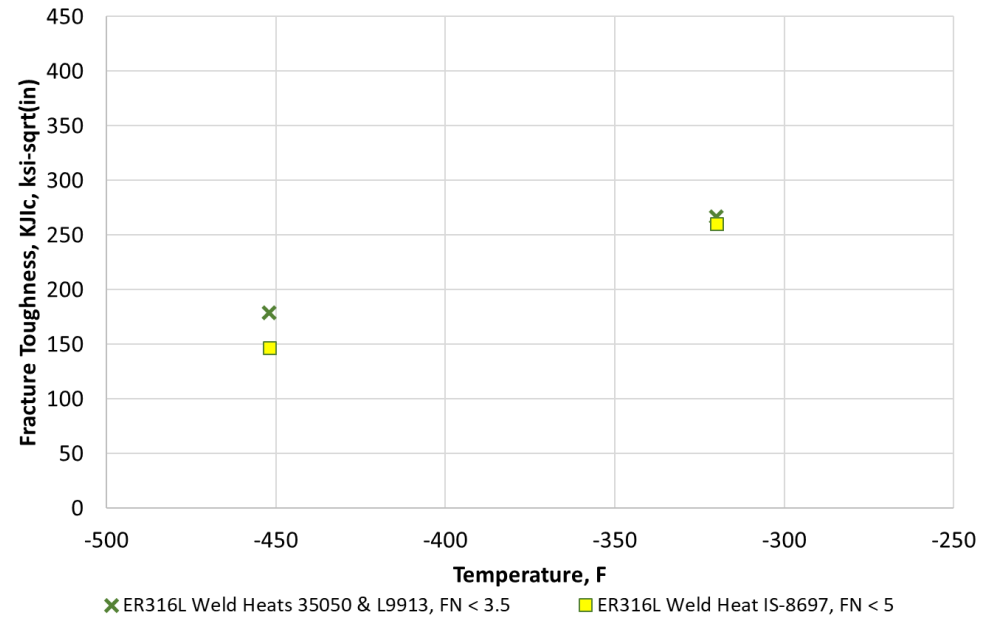

- KJ/c versus Temperature is shown. Two plates and two welds only.
- Plates are on the left, and welds are on the right.
- KJ/c decreases in both cases for a decrease in temperature. This decrease is more pronounced for the plate material.

Toughness versus Charpy Lateral Expansion

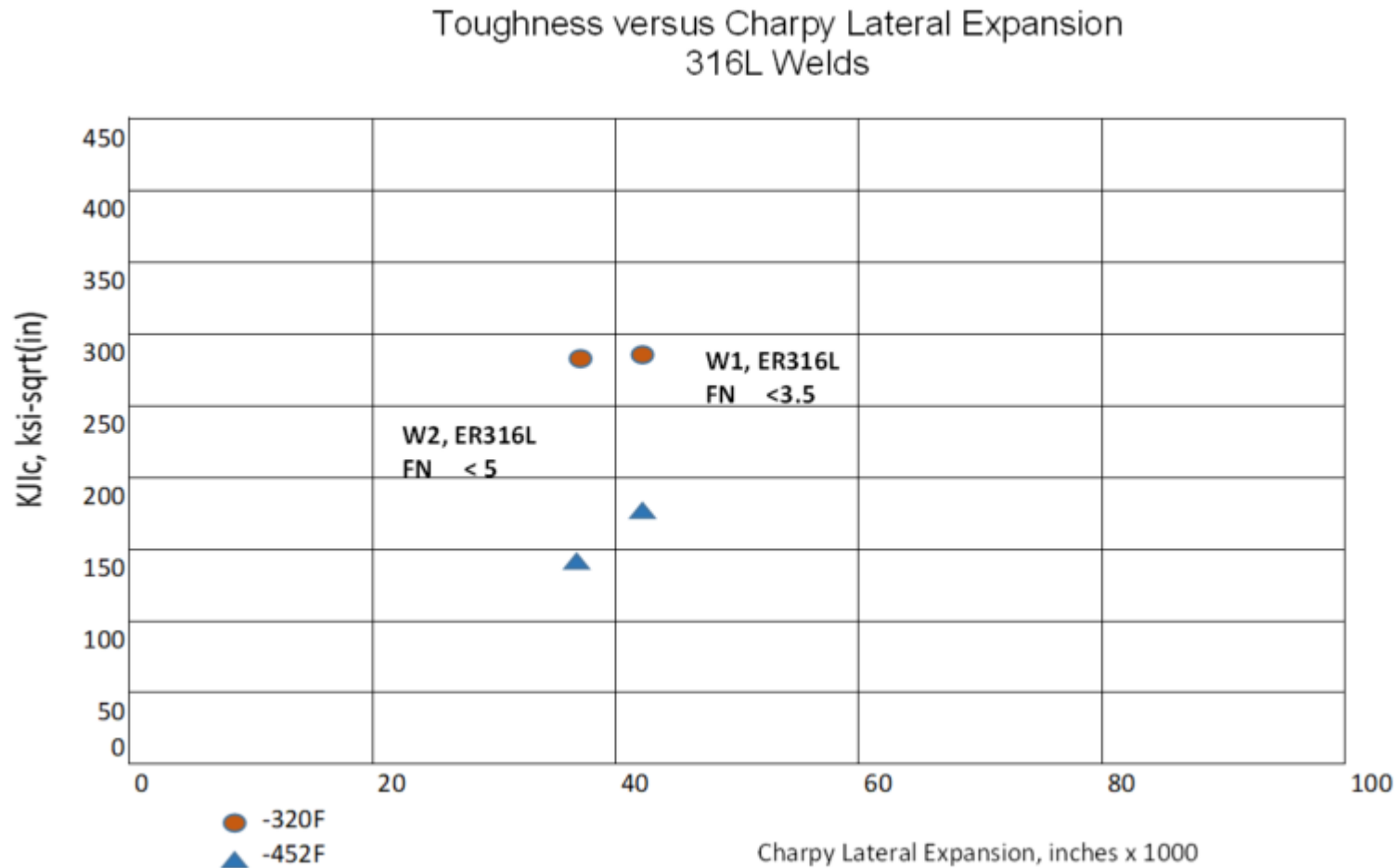

- A correlation may exist between Charpy lateral expansion and -452F toughness in 316L welds. Insufficient data is available.

Toughness versus Ferrite Number

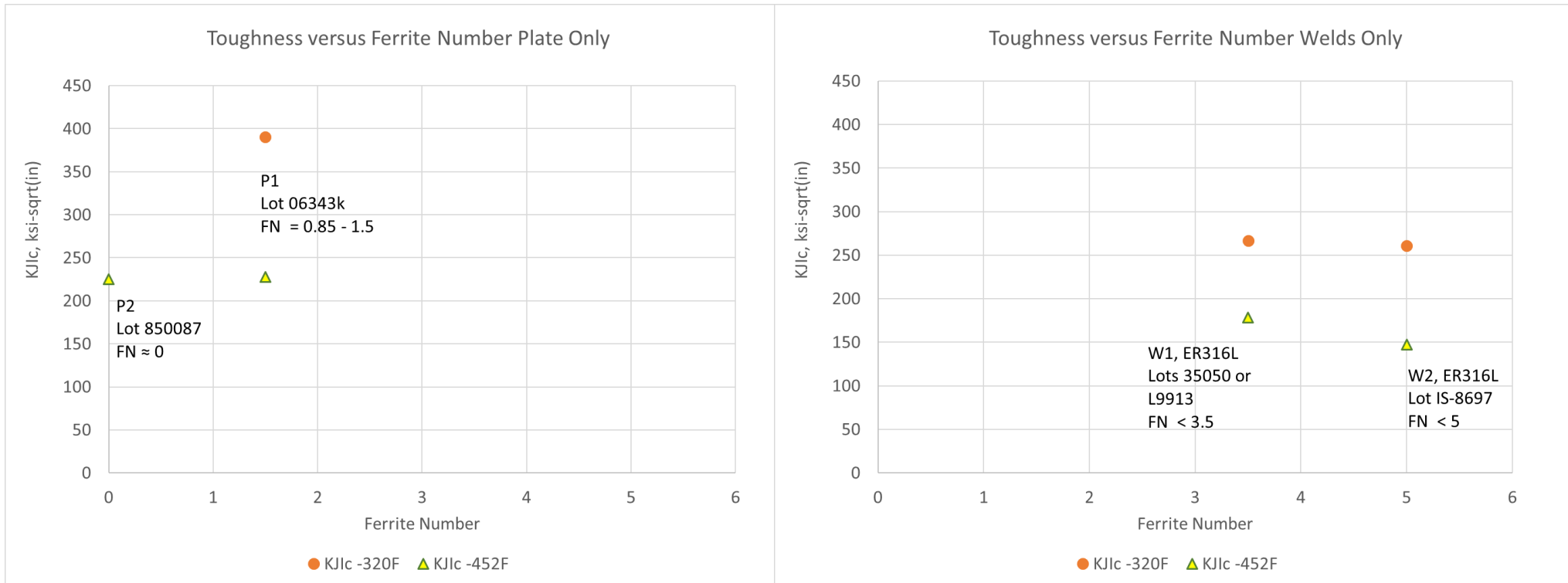

- Toughness, KJIC of plates (left) and welds (right) are shown.
- Toughness at -452F is clearly below toughness at -320F in all cases.
- Toughness measures do not necessarily diminish monotonically when FN increases as can be seen in both figures. The variability of toughness can be large and may overcome this conclusion.

Critical Crack Size

- A “minimum fracture toughness” was calculated using mean minus 8.12 x standard deviation (based on 95% confidence of 99% survival if 10 data points were available – only 2 are).
- The following minimum fracture toughness values were used to estimate critical crack size:
 - Plate: 151.5 ksi-sqrt(in)
 - Weld: 31.8 ksi-sqrt(in)
- Using design pressure, the minimum weld fracture toughness, the maximum longitudinal stress in each case, and using the CGA pipe sizes:
 - The critical flaw size was estimated at 1.09 inches (two sided flaw). This is consistent across all of the CGA pipe sizes, and a surface flaw will grow to a leak-before-break condition ($K < K_{critical}$ using NASGRO, see backup slides).
- If the operating pressures are used instead, with the minimum weld fracture toughness, the maximum longitudinal stress in each case, and using the CGA pipe sizes:
 - The smallest critical initial crack size was 3.26 inches (two sided flaw).
- The results used for this analysis used the 316L properties, but a survey of the CGA pipes in use indicated that all were 304 stainless.

Test Significance

1. The 316L stainless steel material appears to be very tough, relative to the design pressures, with minimum results (**mean minus 8.12 sigma**) producing a flaw that is leak-before-burst, and that only becomes critical when the flaw reaches **1.09 inches**.

This analysis lacks in statistical significance, although the numbers were chosen in a conservative manner.

2. Fracture toughness at -452F appears to correlate with Charpy impact testing at -320F, but little data is currently available.
3. Fracture toughness at -452F may correlate with fracture toughness at -320F, but little data is currently available.
4. Fracture toughness at -452F may correlate inversely with ferrite number, but little data is currently available.
5. Reducing the allowable stress would increase the critical flaw size.

Additional Testing Recommended

- Four 304L samples comprising a mix of 304L parent plate and welds might be considered, with welded versus plate TBD.
- This will provide more fully developed information in the predominantly used material, 304L.
- If the 304L results follow the pattern of 316L then a combination or comparison of results may be useful.
- This work could probably be completed in FY19 depending on availability of funds.
- CGA sample systems were all 304 or 304L stainless steel, but at relatively low stresses, and first phase of testing used 316L to maximize probability of successful results.

Project Cost to Date

Fund Source	Funds Allocated	Expenditures	Total Cost
ASME	\$40,000	Sample prep and testing (Marshall Space Flight Center and Westmoreland Labs)	\$36,210
NASA	\$177,473	Sample prep and testing (Marshall Space Flight Center and Westmoreland Labs)	\$133,714
		Material and welding (Glenn Research Center)	\$9,500
		Test planning and analysis (Marshall Space Flight Center)	\$16,800
		NASA TOTAL	\$160,014

Testing Details

The following identifies a typical round of testing proposed.

Quantity	Test Type	Env.	Temp (F)
1	Ferrite Number	n/a	n/a
2	Tensile	LHe	-452
5	Fracture JIC	LHe	-452
3	Tensile	LN2	-320
5	Instrumented Charpy	LN2	-320
5	Fracture JIC	LN2	-320
1	Tensile Spare	n/a	n/a
1	Fracture Spare	n/a	n/a

Funding Needs

- **Cost to ASME for the proposed additional testing** for specimen preparation and testing would be about **\$145,000**, based on costs from earlier efforts (this would lead to a total expenditure by ASME of about \$181,000).
- **Cost to NASA for the proposed additional testing** for welding, administration, analysis, and reporting would be about **\$25,000**, (this would lead to a total expenditure by NASA of \$182,000).

BACKUP SLIDES

Estimated Minimum Fracture Toughness

Identity	FN	-320F Charpy, lateral expansion, in*10³	-320F KJIC, ksi-sqrt(in)	Estimated -452F KJIC, ksi-sqrt(in)
316L Weld, W1	3.5	< 0	158.7	≈ 0
316L Weld, W2	5	3.5	135.6	31.8
316L Plate, P1	1.2	57.5	144.6	151.5
316L Plate, P2	0			
304L Plate, P3		59.3		

- Minimum fracture toughness was estimated by using the mean in each case and subtracting a factor 8.12 times the standard deviation (95% confidence of 99% survival, with 10 data points). The results are summarized, above.

NASGRO Run to Consider LBB Design Stress

THRESHOLD CRACK SIZE DETERMINATION

DATE: 15-Aug-18 TIME: 12:50:19.55
 NASGRO(R) Version 8.20 (DLL), January 2017
 Final Version

Copyright(c) 2017 Southwest Research
 Institute(R).
 All Rights Reserved.

U.S. customary units [in, in/cycle, kips, ksi, ksi
 sqrt(in)]

MODEL: SC05

Crack Type = INTERNAL

Cylinder Thickness, $t = 0.1330$
 Outer Diameter, $D = 1.3150$
 Poissons Ratio, $\nu = 0.3300$

Crack Aspect Ratio: $a/c = 0.8000$

Critical Material Properties:

Fracture Toughness, $K_{cr} = 31.8000$
 Yield (or Flow) Stress, $S_{cr} = 113.3000$

Applied Stresses:

$S_0 = 20.0000$
 $S_1 = 0.0000$

Design Stress

Valid Range of Crack Size:

The maximum allowed crack size, $a_{max} = 1.3300E-01$

The minimum allowed crack size, $a_{min} = 1.3301E-05$

Iteration Method: Regula Falsi Method
 (EPS=0.1%)

SC05

internal or external crack

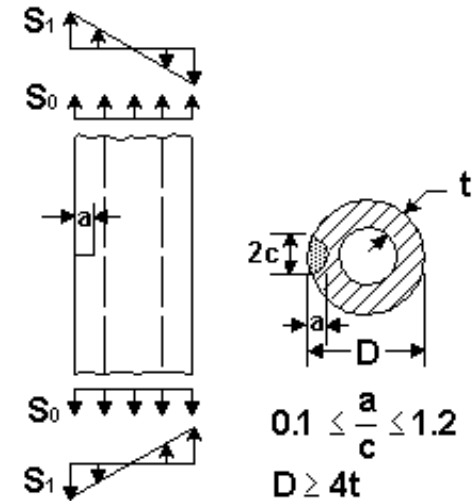

SOLUTION THROUGH SIF CHECK:

$K(a) < K_{cr}$ in the region $[a_{min}, 99\%a_{max}]$.
CCS does not exist in the region by SIF check.

CCS determined by SIF: $a > 1.3167E-01$ (99% a_{max}).

SOLUTION THROUGH NSY CHECK:

$S_n(a) < S_{cr}$ in the region $[a_{min}, 99\%a_{max}]$.
CCS does not exist in the region by NSY check.

CCS determined by NSY: $a > 1.3167E-01$ (99% a_{max}).

FINAL SOLUTION:

Critical crack size: $a > 1.3167E-01$ (99% a_{max}).
 CCS determination is based on both K_{max} and NSY.

Note: Crack depth + Yield zone exceeds or equals thickness.

This version of NASGRO(R) is limited to official NASA, ESA, and
 FAA business only.
 All other uses prohibited.

NASGRO Run

Design Stress

THRESHOLD CRACK SIZE DETERMINATION

=====

DATE: 17-Aug-18 TIME: 12:58:53.92
 NASGRO(R) Version 8.20 (DLL), January 2017
 Final Version
 Copyright(c) 2017 Southwest Research Institute(R).
 All Rights Reserved.

U.S. customary units [in, in/cycle, kips, ksi, ksi sqrt(in)]

MODEL: TC07

Thickness, $t = 0.1330$
 Outer Diameter, $D = 1.3150$

Critical Material Properties:
 Fracture Toughness, $K_{cr} = 31.8000$
 Yield (or Flow) Stress, $S_{cr} = 113.3000$

Applied Stresses:
 $S_0 = 10.0000$

Design Stress

Valid Range of Crack Size:
 The maximum allowed crack size, $c_{max} = 2.8036E+00$
 The minimum allowed crack size, $c_{min} = 0.0000E+00$

Iteration Method: Regula Falsi Method (EPS=0.1%)

TC07

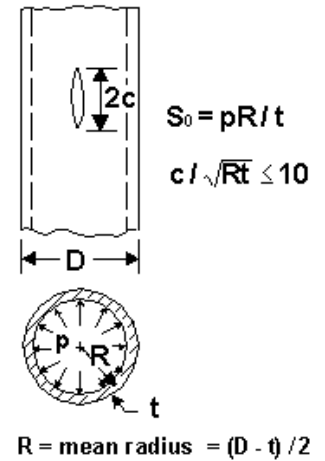

SOLUTION THROUGH SIF CHECK:

Iteration table within root bracket [2.7756E-01,5.5512E-01]:

i	c(i)	K(i)	[K(i)-Kcr]/Kcr
0	5.5512E-01	3.2435E+01	2.00%
1	5.4504E-01	3.1723E+01	-0.24%
2	5.4612E-01	3.1800E+01	--.00%

CCS determined by SIF: $c = 5.4612E-01$

SOLUTION THROUGH NSY CHECK:

$S_n(c) < S_{cr}$ in the region [$c_{min}, 99\%c_{max}$].
 CCS does not exist in the region by NSY check.

CCS determined by NSY: $c > 2.7756E+00$ (99% c_{max}).

FINAL SOLUTION:

Critical crack size (CCS):

$c = 5.4612E-01$

$2c = 1.09$ inches

CCS determination is based on both K and NSY.
 CCS is controlled by stress intensity factor.

This version of NASGRO(R) is limited to official NASA, ESA, and FAA business only.

All other uses prohibited.

Validating an Aging, Non-compliant Product

NASGRO Run to Consider LBB Worst Case Operating Pressure

THRESHOLD CRACK SIZE DETERMINATION

DATE: 17-Aug-18 TIME: 13:05:04.30
 NASGRO(R) Version 8.20 (DLL), January 2017
 Final Version
 Copyright(c) 2017 Southwest Research Institute(R).
 All Rights Reserved.

U.S. customary units [in, in/cycle, kips, ksi, ksi sqrt(in)]

MODEL: SC04

Cylinder Thickness, $t = 0.1330$
 Outer Diameter, $D = 1.3150$

Crack Type = INTERNAL

Crack Aspect Ratio: $a/c = 1.0000$

Critical Material Properties:

Fracture Toughness, $K_{cr} = 31.8000$
 Yield (or Flow) Stress, $S_{cr} = 113.3000$

Applied Stresses:

$S_0 = 5.0700$

Operating Stress

Valid Range of Crack Size:

The maximum allowed crack size, $a_{max} = 1.3300E-01$
 The minimum allowed crack size, $a_{min} = 0.0000E+00$

Iteration Method: Regula Falsi Method (EPS=0.1%)

SC04

internal or external crack

$S_0(X)$ = stresses due to internal pressure, p
 $S_i(X)$ = other stresses

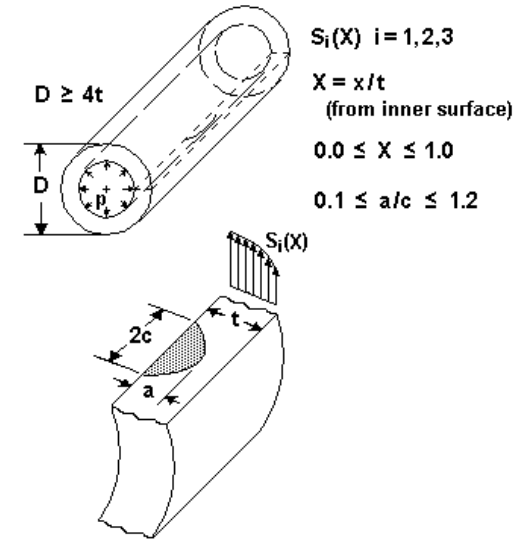

SOLUTION THROUGH SIF CHECK:

$K(a) < K_{cr}$ in the region $[a_{min}, 99\%a_{max}]$.

CCS does not exist in the region by SIF check.

CCS determined by SIF: $a > 1.3167E-01$ (99% a_{max}).

SOLUTION THROUGH NSY CHECK:

$S_n(a) < S_{cr}$ in the region $[a_{min}, 99\%a_{max}]$.

CCS does not exist in the region by NSY check.

CCS determined by NSY: $a > 1.3167E-01$ (99% a_{max}).

FINAL SOLUTION:

Critical crack size: $a > 1.3167E-01$ (99% a_{max}).

CCS determination is based on both K_{max} and NSY.

This version of NASGRO(R) is limited to official NASA, ESA, and FAA business only.
 All other uses prohibited.

NASGRO Run

Worst Case Operating Pressure

TC07

THRESHOLD CRACK SIZE DETERMINATION

=====

DATE: 21-Aug-18 TIME: 07:03:33.43
 NASGRO(R) Version 8.20 (DLL), January 2017
 Final Version
 Copyright(c) 2017 Southwest Research Institute(R).
 All Rights Reserved.

U.S. customary units [in, in/cycle, kips, ksi, ksi sqrt(in)]

MODEL: TC07

Thickness, $t = 0.1330$
 Outer Diameter, $D = 1.3150$

Critical Material Properties:

Fracture Toughness, $K_{cr} = 31.8000$
 Yield (or Flow) Stress, $S_{cr} = 113.3000$

Applied Stresses:

$S_0 = 2.5350$

Operating Stress

Valid Range of Crack Size:

The maximum allowed crack size, $c_{max} = 2.8036E+00$
 The minimum allowed crack size, $c_{min} = 0.0000E+00$

Iteration Method: Regula Falsi Method (EPS=0.1%)

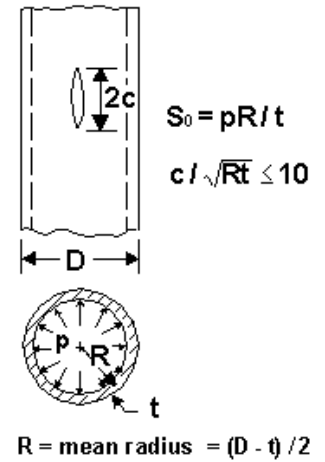

SOLUTION THROUGH SIF CHECK:

Iteration table within root bracket [1.3878E+00,1.6654E+00]:

i	c(i)	K(i)	[K(i)-Kcr]/Kcr
0	1.6654E+00	3.2607E+01	2.54%
1	1.6312E+00	3.1797E+01	-0.01%

CCS determined by SIF: $c = 1.6312E+00$

SOLUTION THROUGH NSY CHECK:

$S_n(c) < S_{cr}$ in the region $[c_{min}, 99\%c_{max}]$.
 CCS does not exist in the region by NSY check.

CCS determined by NSY: $c > 2.7756E+00$ (99% c_{max}).

FINAL SOLUTION:

Critical crack size (CCS):
 $c = 1.6312E+00$
 CCS determination is based on both K and NSY.
 CCS is controlled by stress intensity factor.

2c = 3.26 inches

This version of NASGRO(R) is limited to official NASA, ESA, and FAA business only.
 All other uses prohibited.

