

Anomalous Uses of Mass Spectrometers at NASA

National Aeronautics and
Space Administration

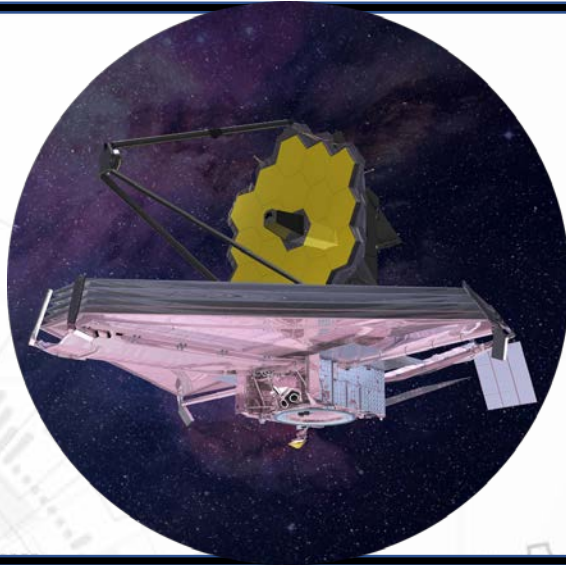

Kathleen B. Loftin, Ph.D
Deputy Chief Technologist
Kennedy Space Center

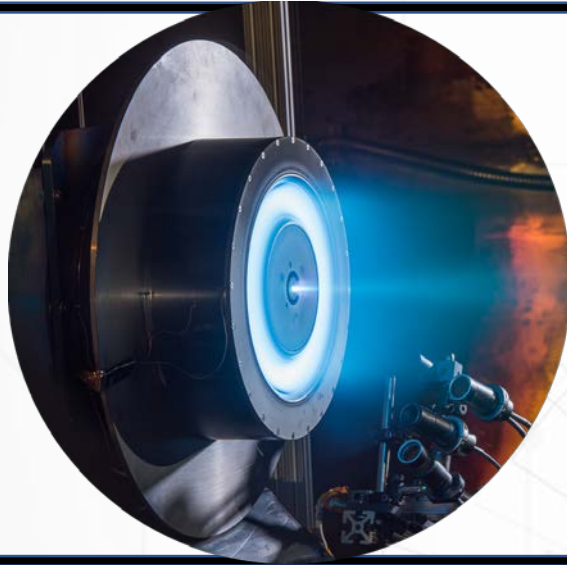

My Background

Education:

- Bachelor's and Ph.D. in Chemistry (Environmental and Materials Track), University of Central Florida
- Master's of Science Industrial Chemistry, University of Central Florida

Career:

Before NASA

- Environmental Analytical Chemist/Supervisor (private labs, Walt Disney World)

NASA

- Research Scientist, Principal Investigator, Subject Matter Expert
- Deputy Chief Technologist

Outside of work:

- Family, Outdoor activities, and adventures,



Objective

- Discuss alternative Mass Spec Applications at NASA
- Challenge Innovative Solutions

Background: We (HEMS) Focus on Bringing the Instrument to the Sample Because it's not Practical to Bring the Sample to the Lab

National Aeronautics and
Space Administration



NASA Focus Areas

- Global Studies
 - Atmospheric studies
- Planetary Science
 - Atmospheric studies
 - Organic volatiles and nonvolatile
 - Elemental and mineral identification
- Grounds Systems
 - Leak detection of fuels, toxic vapors, and purge gases

A Few NASA Applications Where We Bring the Samples to the Instrument



1. Space Shuttle Aft Gas Analysis* –evacuated autonomous sampling containers required
2. Anomaly investigations*- requires sample wipes, tape lifts, etc
 - Contamination Identification
 - Particles, films, liquids
 - Often trace forensic “unknown” unknowns
 - Requires a suite of instruments spectroscopy and spectrometry
 - Organic volatiles and nonvolatile
3. Preflight Applications*
 - Cleanliness verifications
 - Commodity and fuel purity

**Ripe for Innovative Solutions*



Atlantis
Discovery
Endeavour

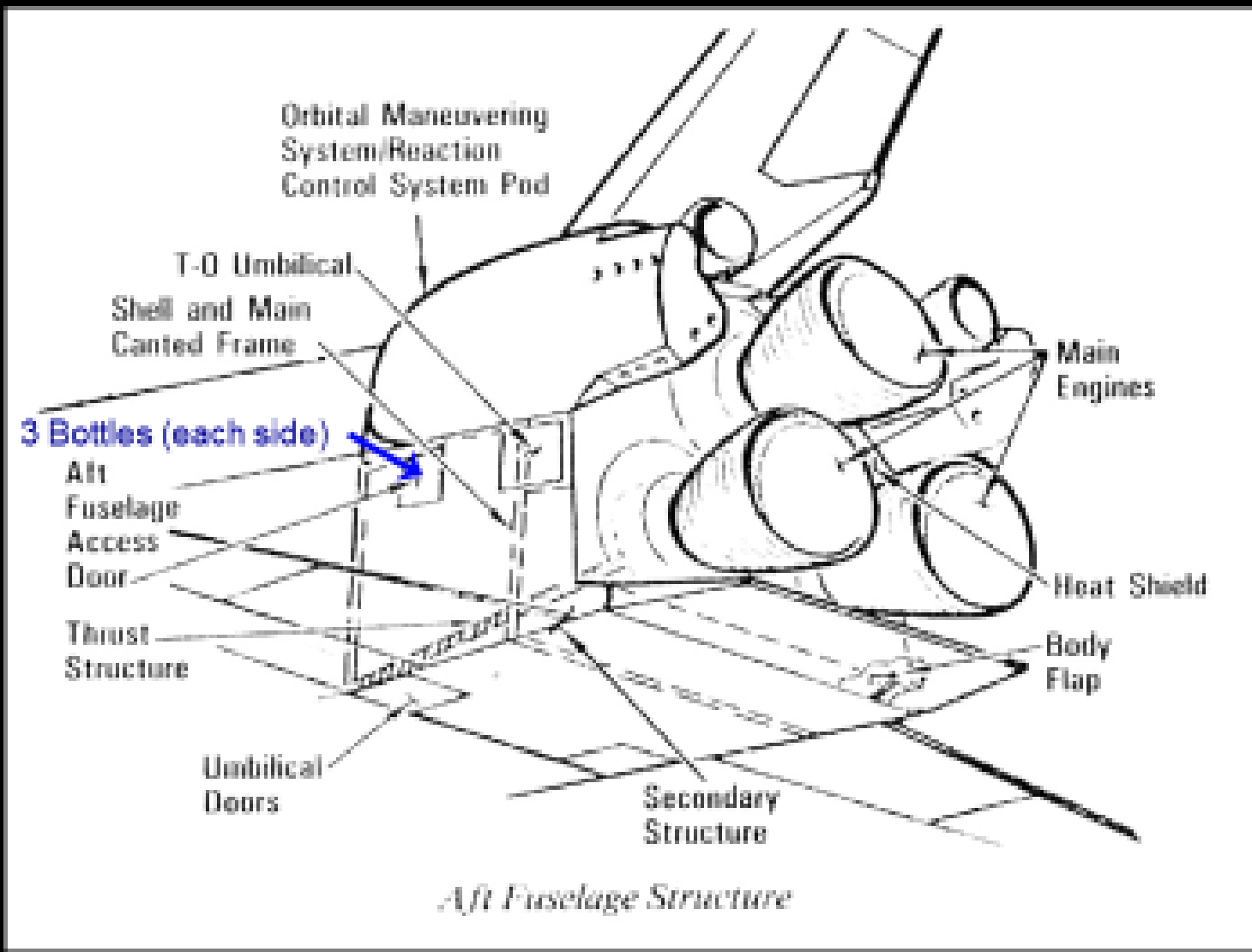



Aft Gas Requirements

- Six Evacuated Bottles in Aft of Orbiter During Ascent
- Opened at Specific Times During Ascent
- Bottles Removed After Mission
- All Pressures Sub Ambient
 - 2 – 175 torr
- Analyzed for Commodities of Interest for Main Engine
 - H₂, He, O₂, Ar, CH₄, CO, CO₂
 - Detection Limits of 0.01 %
- Used to Help Evaluate Main Engine Performance



Analytical Technique

Utilizes GC/MS along with Custom Sample Inlet

Detect Parts-Per-Million of Commodities

Monitor any Gas with Molecular Weight below 50 Daltons

Can Be Sub Ambient

Small Sample Volumes

Performs Shuttle Aft Gas Analysis



36



Why Do We Use Permanent Instruments?

Nothing available currently that addresses these issues:
(Closest reflective IR)

- Samples are in awkward locations geometrically
- Contaminants of interest are not necessarily volatile
- Sample may be coated on a hardware that can't be removed
- Hardware must be treated with delicacy
- Need accuracy and selectivity



What if could bring the instruments to the samples?

Advantages

- Less potential sampling artifacts
- Real time data
- Environmentally friendly

Other Markets

1. Commercial Aerospace
2. Forensics- crime scene
3. Medical- real time diagnostics

For Inorganic Compounds there are COTS instruments available, XRF. Maybe make a combo instrument?



What would it look like?

- Let's discuss



Innovation

- Converting ideas into value