



Helium Pressurization Modeling of the EDU Submerged Diffuser Using Thermal Desktop

Daniel Hauser
NASA Glenn Research Center

JANNAF In-Space Chemical Propulsion TIM, AUG 29-30, 2018



Submerged Pressurization Objective

- In micro-gravity, the effects of surface tension dominate over gravity forces and the liquid no longer remains in a settled condition.
- The fluid behavior/location is highly dependent on the small accelerations and fluid level experienced during a mission.
- As a result for a given pressurization system, the diffuser may be exposed to the tank ullage when the propellant is settled, but maybe exposed when the propellant is unsettled.
- Potential issues were identified with submerged diffuser pressurization:
 - Pressuring gas collapses as it passes through the liquid. More helium is required as a result.
 - Helium can dissolve within the propellant. More helium is required as a result.
 - The ability to control pressure within a specific range is unknown (focus of the 2015 EDU tests)



EDU Submerged Pressurization Modeling Overview



- Conjugate Fluid/Thermal Multi-node model of EDU diffuser tank experiment modeled in Thermal Desktop.
- Purpose of multi-node model is to understand dominant physical phenomena before higher fidelity CFD modeling is performed.
 - Cooling of GHe within diffuser.
 - Cooling of GHe via screen
 - Cooling of GHe/GH2 mixture
 - Dissolution of GHe in LH2.
- Model has fidelity to simulate thermal heat load into tank including thermal mass as well with the liquid, vapor, and interface modeled as single nodes.
 - Heat transfer between liquid, vapor, interface and tank walls allowed by specifying empirical convection estimate based on natural convection.



EDU Tank Assembly

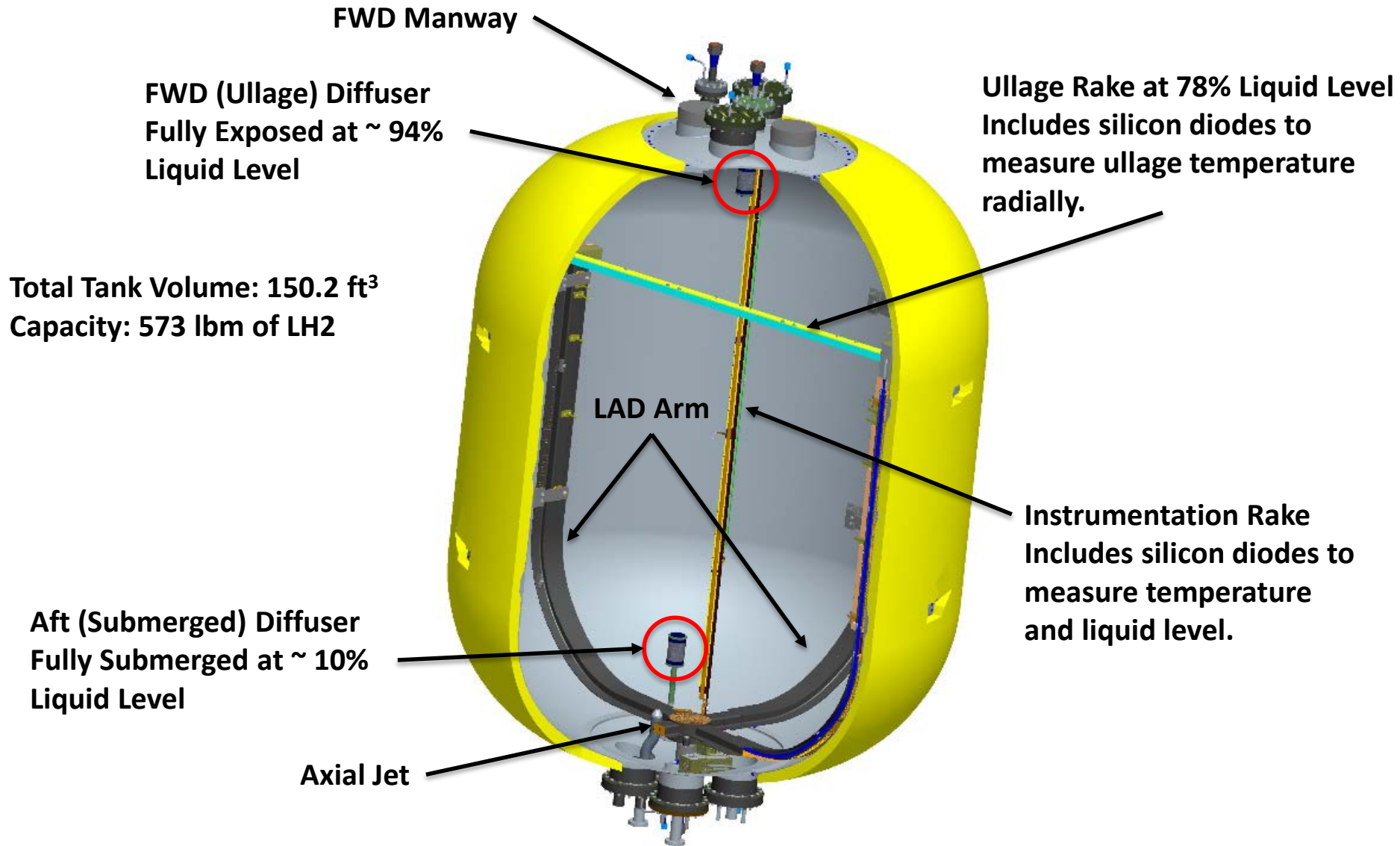



EDU Diffuser Assembly

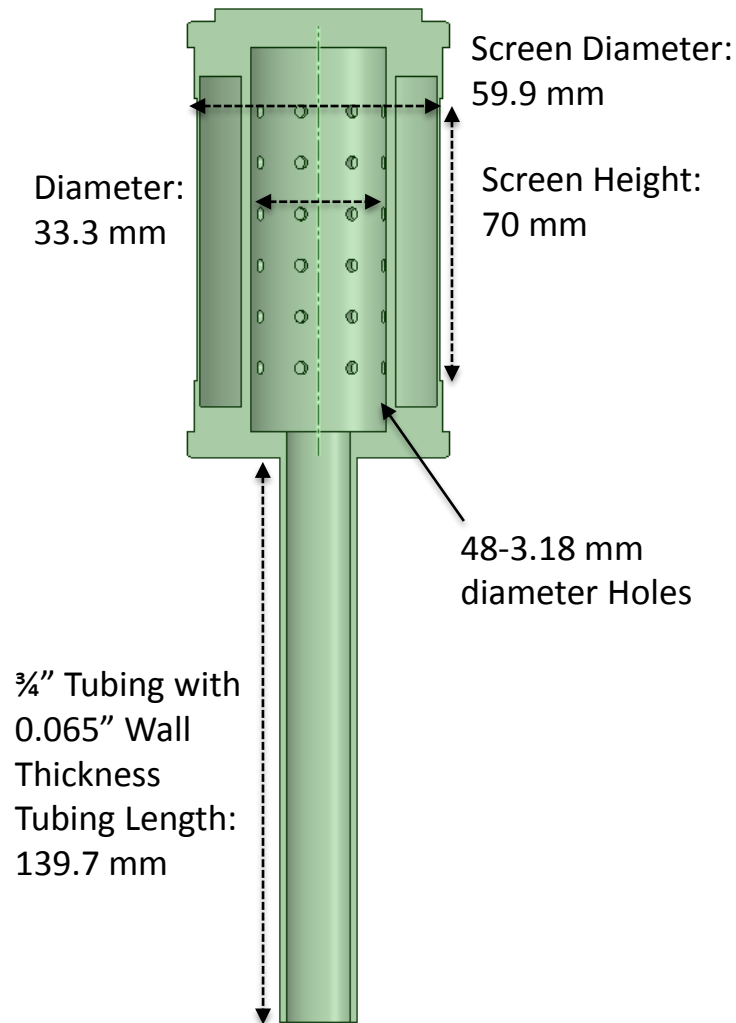

Screen Details

Mesh Size: 50 per 2.54 cm
Wire Diameter: 0.2286 mm
Opening: 0.2794 mm
Opening %: 30%





EDU Pressurization Schematic



Facility/EDU
Press Gas
Interface

Gaseous ambient
helium provided to EDU
by the test facility.

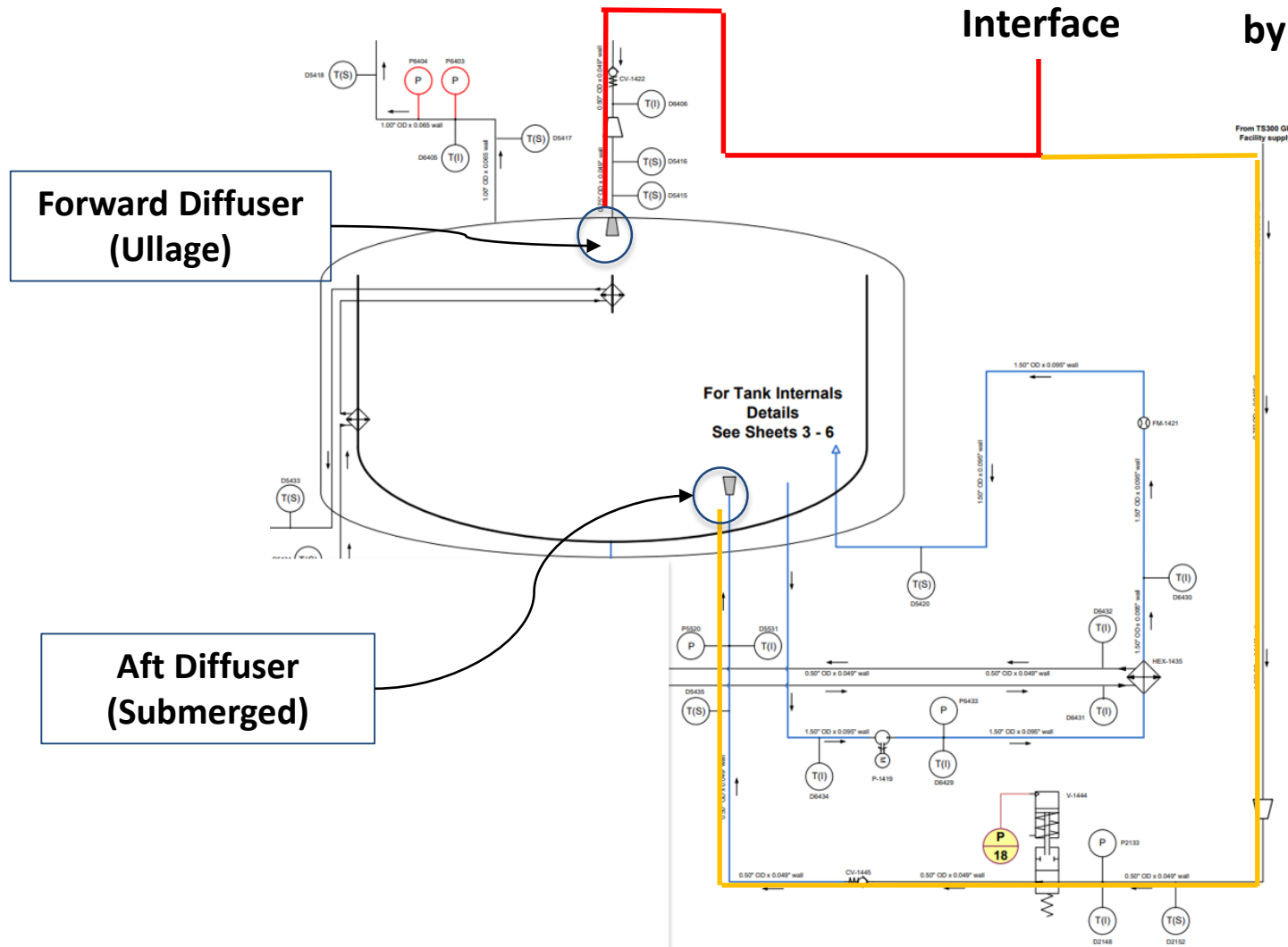



TD Model of Tank Pressurization

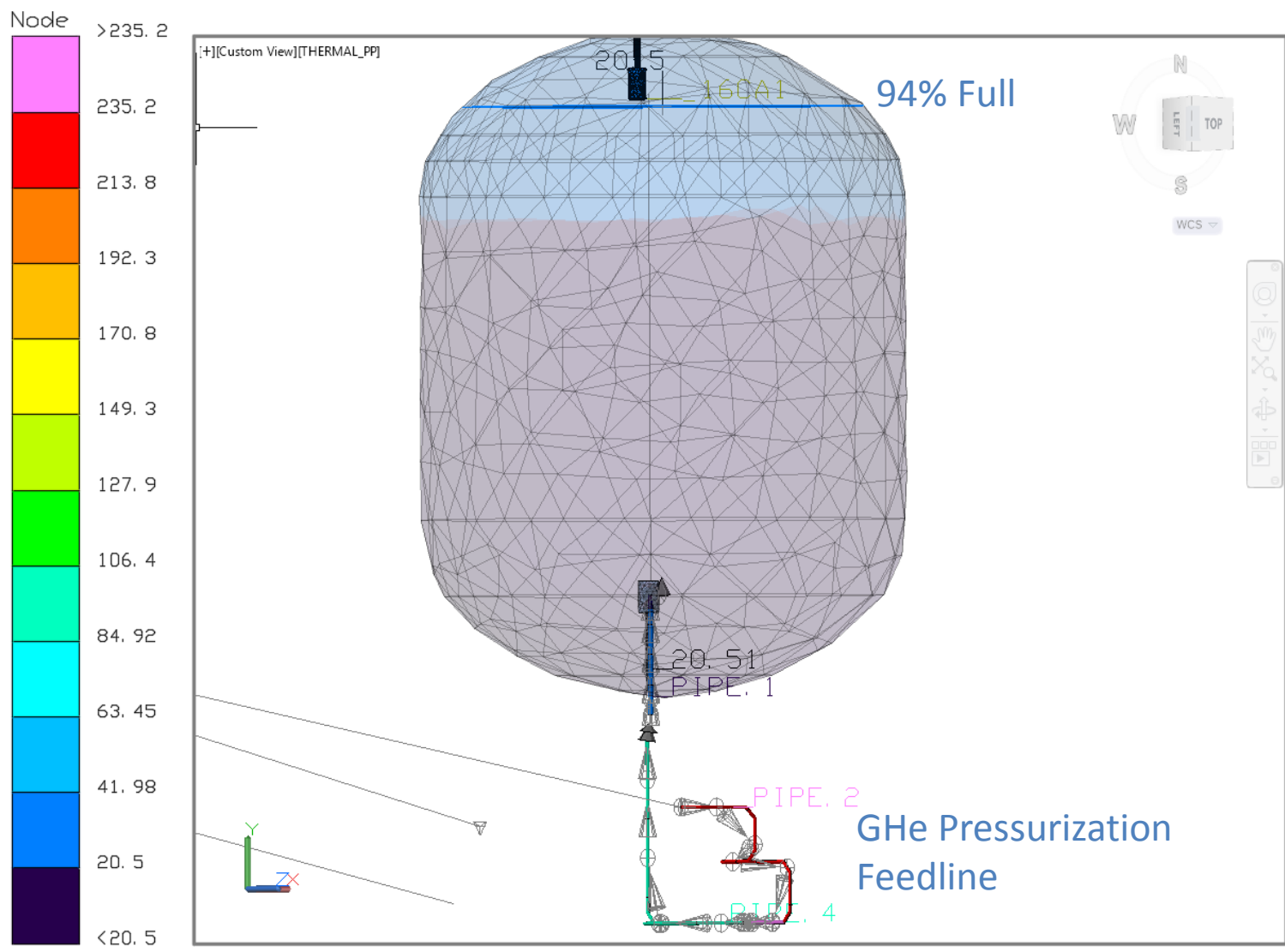

Temperature [K], Time = 0 sec



Model Assumptions



- Liquid and Gas modeled as separate lumps with a liquid/vapor interface temperature to account for heat and mass transfer between phases.
- Liquid and Vapor to interface heat transfer coefficients calculated using natural convection empirical correlations.
- Condensation (mass and heat transfer) in the with presence of a non-condensable modeled using Chilton-Colburn analogy in combination with interfacial energy balances. .

$$\frac{h_v}{\dot{m}'' / (\rho_{C\infty} - \rho_{Ci})} = \left[\frac{P_{tot}}{P_{NCG\infty}} \cdot \rho_{NCG\infty} \cdot \frac{\ln\left(\frac{P_{NCGi}}{P_{NCG\infty}}\right)}{P_{NCGi} - P_{NCG\infty}} \right]^{-1} \cdot \left[\rho \cdot C_p \cdot \left(\frac{k}{D_{lm}}\right)^2 \right]^{1/3}$$

- Conjugate heat transfer between liquid/vapor and walls modeled using two phase heat transfer ties and include the following types of heat transfer.
 - Natural Convection
 - Nucleate, film, and Transition pool boiling.
 - Condensation
- Tank wall assumed to be constant wall thickness with an average heat flux applied to outside of tank wall.



Tank Bubble Rise Model Details



Bubble Size & Velocity

Bubble Velocity

Turbulent

$$u_t = 0.69 \sqrt{\frac{g \cdot D_p \cdot (\rho_L - \rho_g)}{\rho_L}}$$

Laminar

$$u_t = 1.5 \sqrt{\frac{g \cdot D_p \cdot (\rho_L - \rho_g)}{\rho_L}}$$

Bubble Diameter

M. A. Talaia, Terminal Velocity of a Bubble Rise in a Liquid Column, 2007 International journal of Physical and Mathematical Sciences

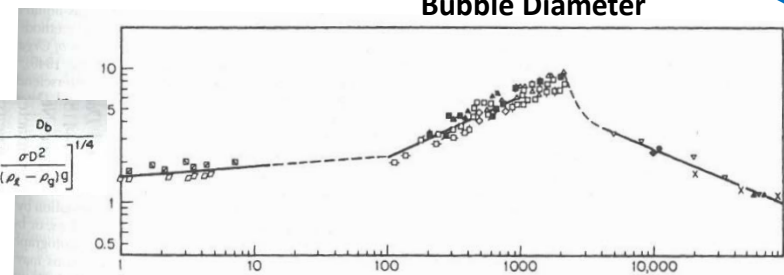

Can J Chem. ENG 54, 503(1976)

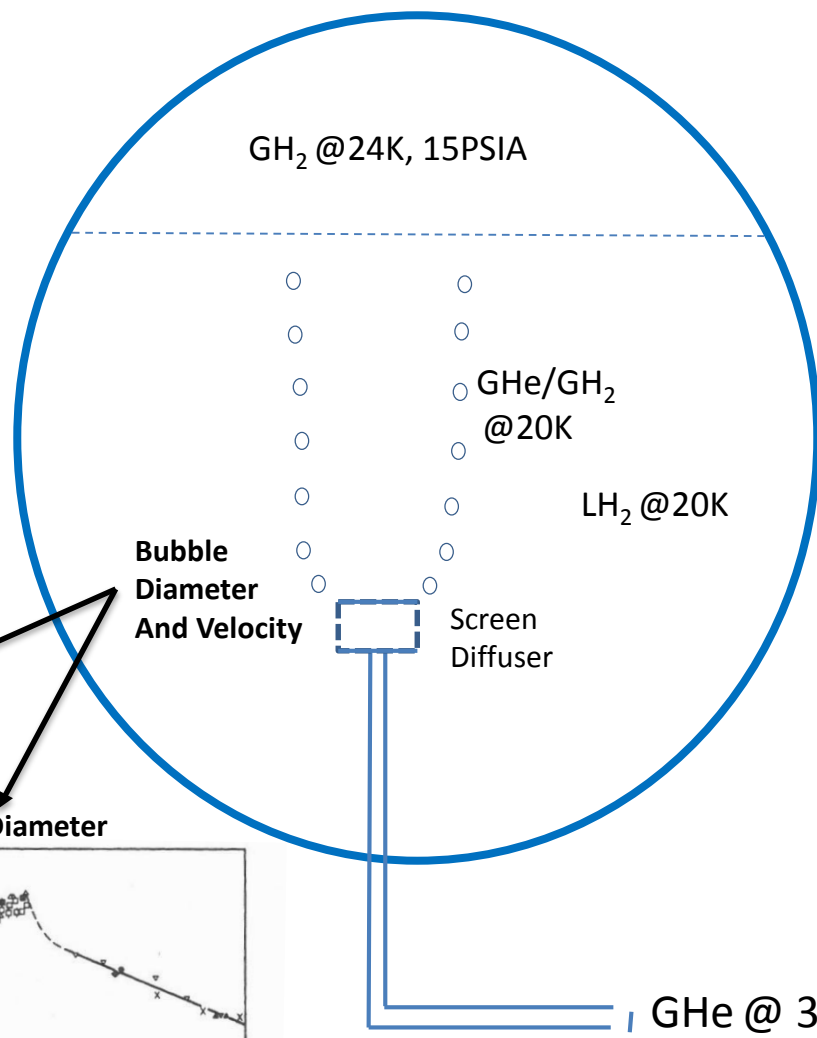

Screen Heat Transfer

Heat transfer from screen and Surrounding LH2

$$Q_{\text{screen,boiling}} = q''_{\text{boiling}} \cdot A_{\text{screen}}$$

q''_{boiling} function of $T_{\text{screen}} - T_{\text{liq}}$



Heat transfer from Screen to GHe

$$Q_{\text{screen,GHe Cooling}} = h_{\text{gas}} \cdot A_{\text{screen}} \cdot (T_{\text{gas}} - T_{\text{screen}})$$

$$Q_{\text{screen,GHe Cooling}} = Q_{\text{screen,boiling}}$$



Helium Dissolution using Bubble Column Correlation



- The dissolution of GHe into LH2 was approximated using GHe/LH2 solubility data and dissolution rate correlations for bubble column.

$$\frac{k_L a \cdot d_b}{D_{He-H_2}} = 0.62 \left[\frac{\mu_L}{\rho_L D_{He-H_2}} \right]^{0.5} \left(\frac{g \rho_L d_b^2}{\sigma} \right)^{0.333} \left(\frac{g \rho_L^2 d_b}{\mu_L^2} \right)^{0.29} \left[\frac{U_G}{(g d_b)^2} \right]^{0.68} \left(\frac{\rho_G}{\rho_L} \right)^{0.04}$$

$k_L a$: Overall Mass Transfer Coefficient, $\frac{kmol}{m^3 \cdot s}$

d_b : bubble diameter, m

D_L : diffusivity of GHe in LH₂, m²/s

U_g : Velocity (Use Terminal Velocity), m/s

Ozturk, et. Al AlcheJ., 33, 1473-1480 (1987)



Helium Dissolution

- The rate of dissolution is the product of the overall mass transfer coefficient times the mole gradient across the liquid/vapor.

- $$m_{He} = k_l a \cdot V_L \cdot MM \cdot (x_{GHe}^* - x_{GHe})$$
$$\frac{kg}{s} = \frac{kmol}{m^3 \cdot s} \cdot [m^3] \cdot \frac{kg}{mol} \cdot \text{mole\%}$$

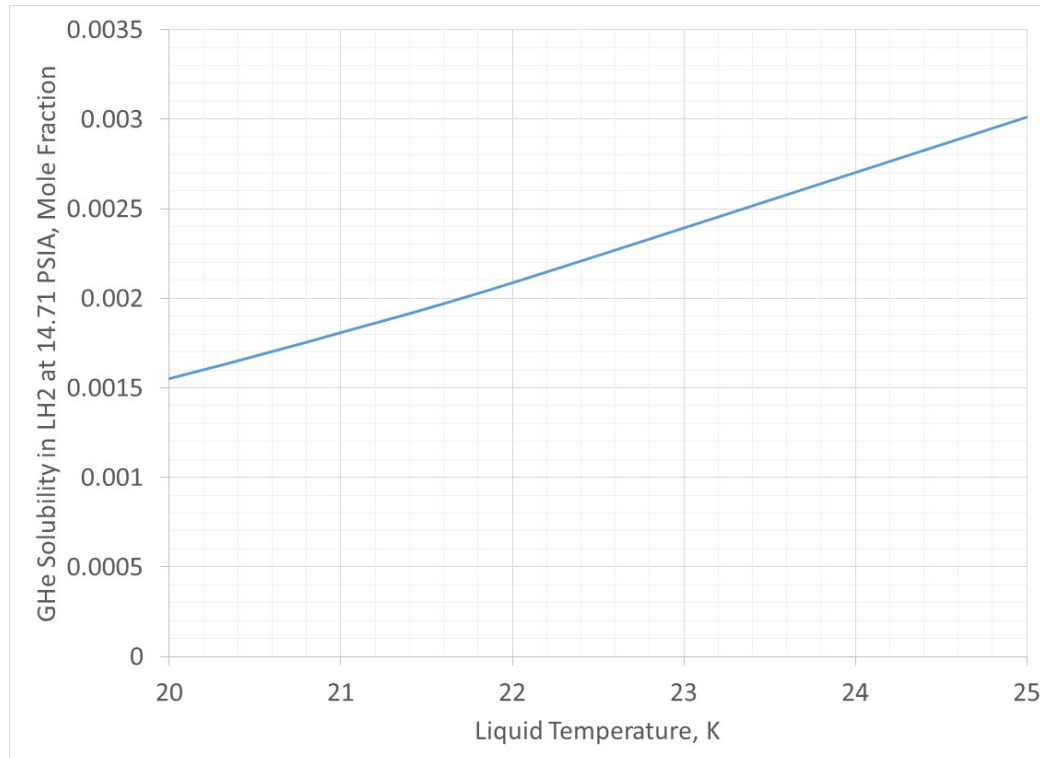

Zimmerli G A, Asipauskas M and Van Dresar N T
2010 *Cryogenics* **50** 556-60



GHe Diffuser Flow Rate (Bang-Bang Pressurization)

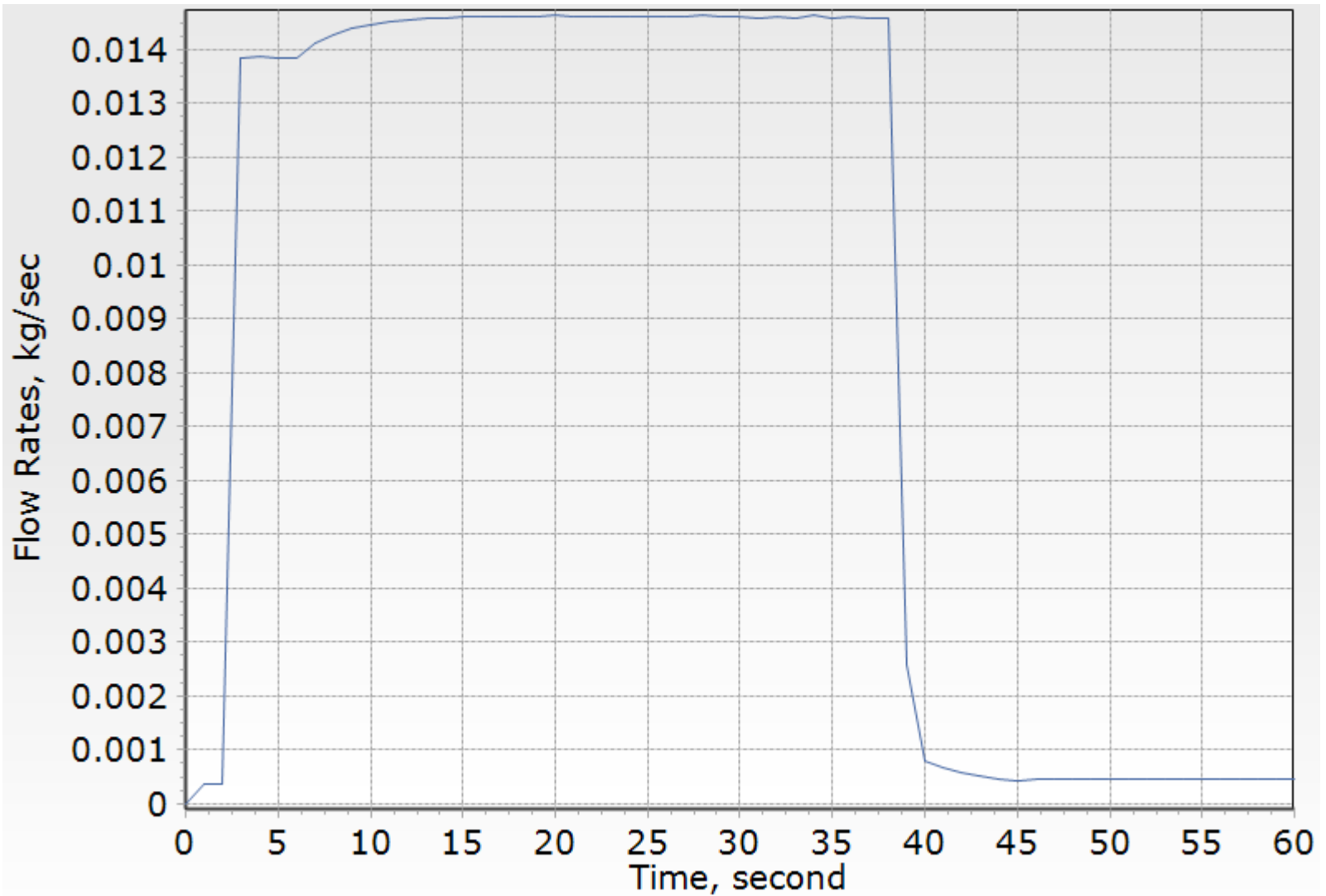



Liquid Volume During Pressurization



click to start video



LH2 Volume Inside Tank During Pressurization

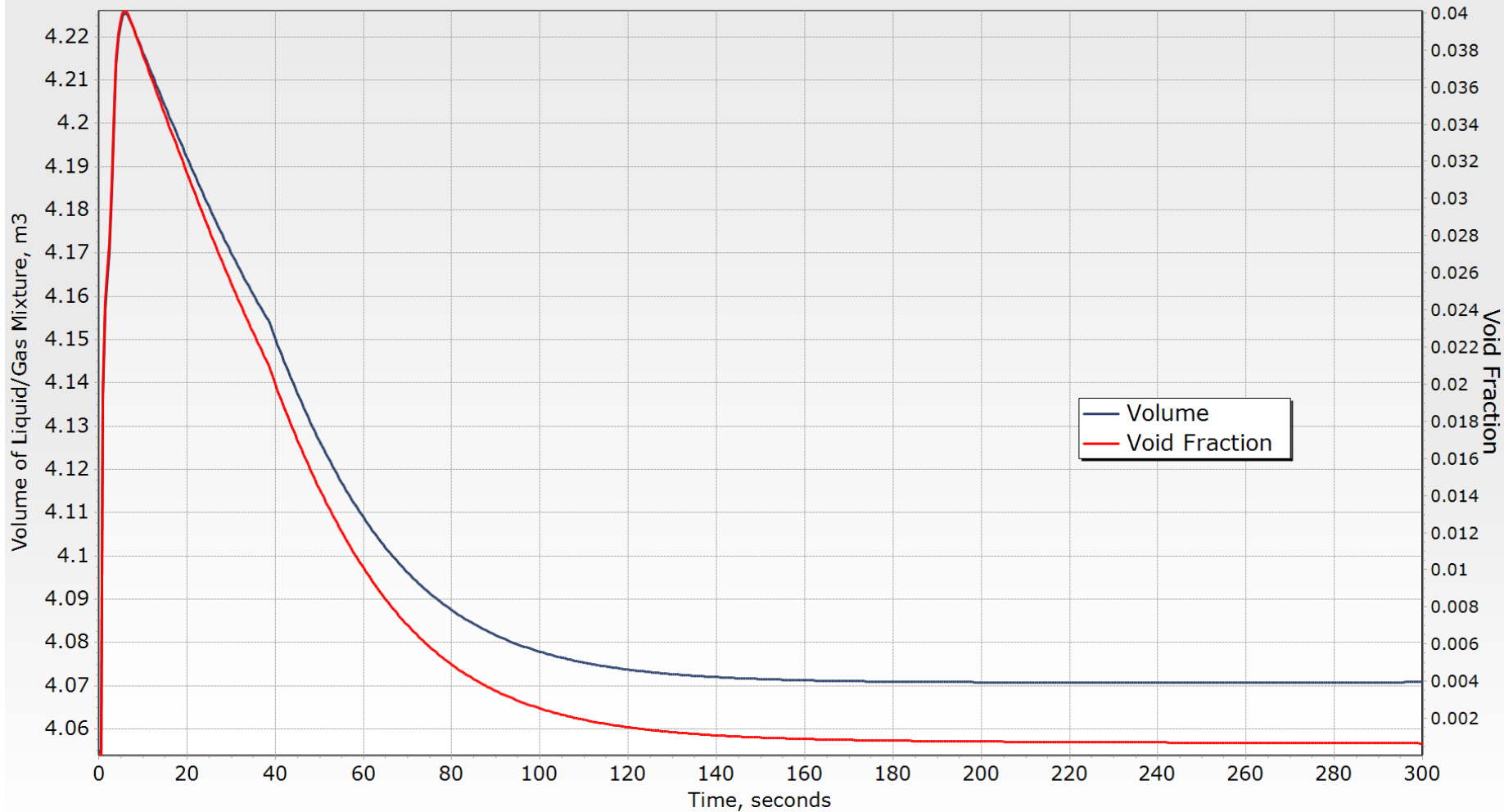

Upper Diffuser Temperature During Pressurization

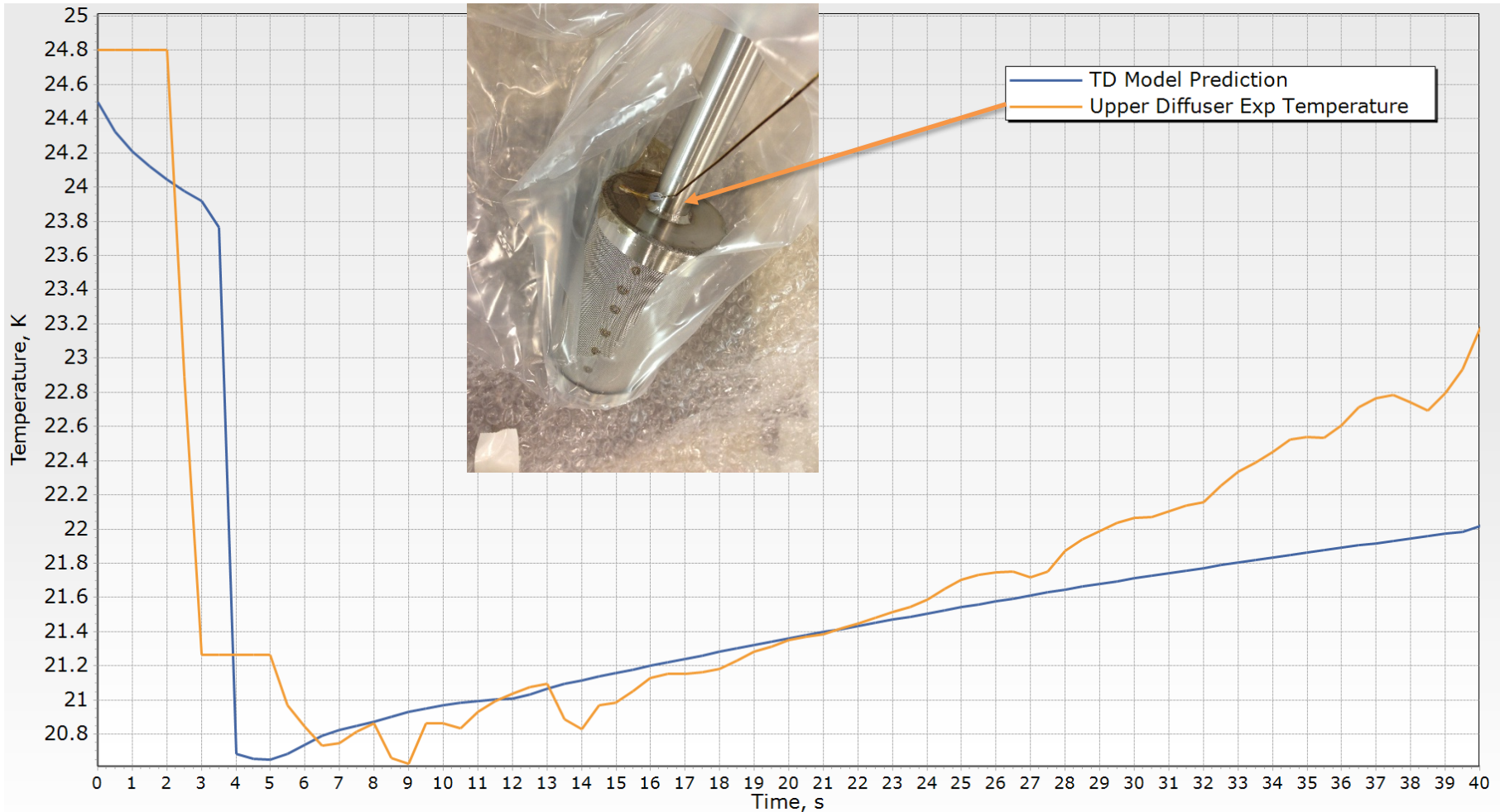



Predicted Pressure at Various Dissolution Rates vs Experimental (Fast Pressurization)

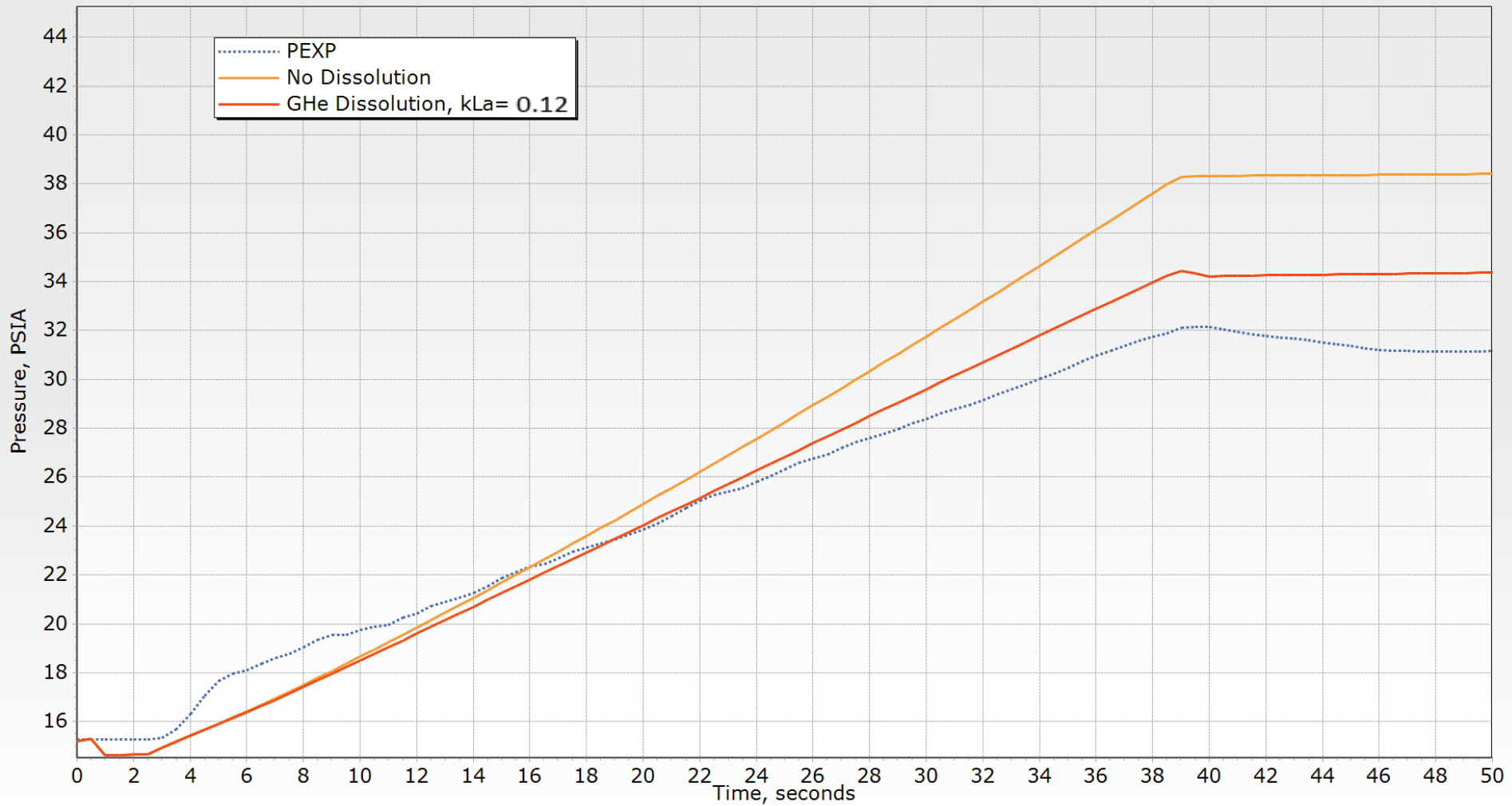



GHe Diffuser Flow Rate(Slow Pressurization Diffuser)

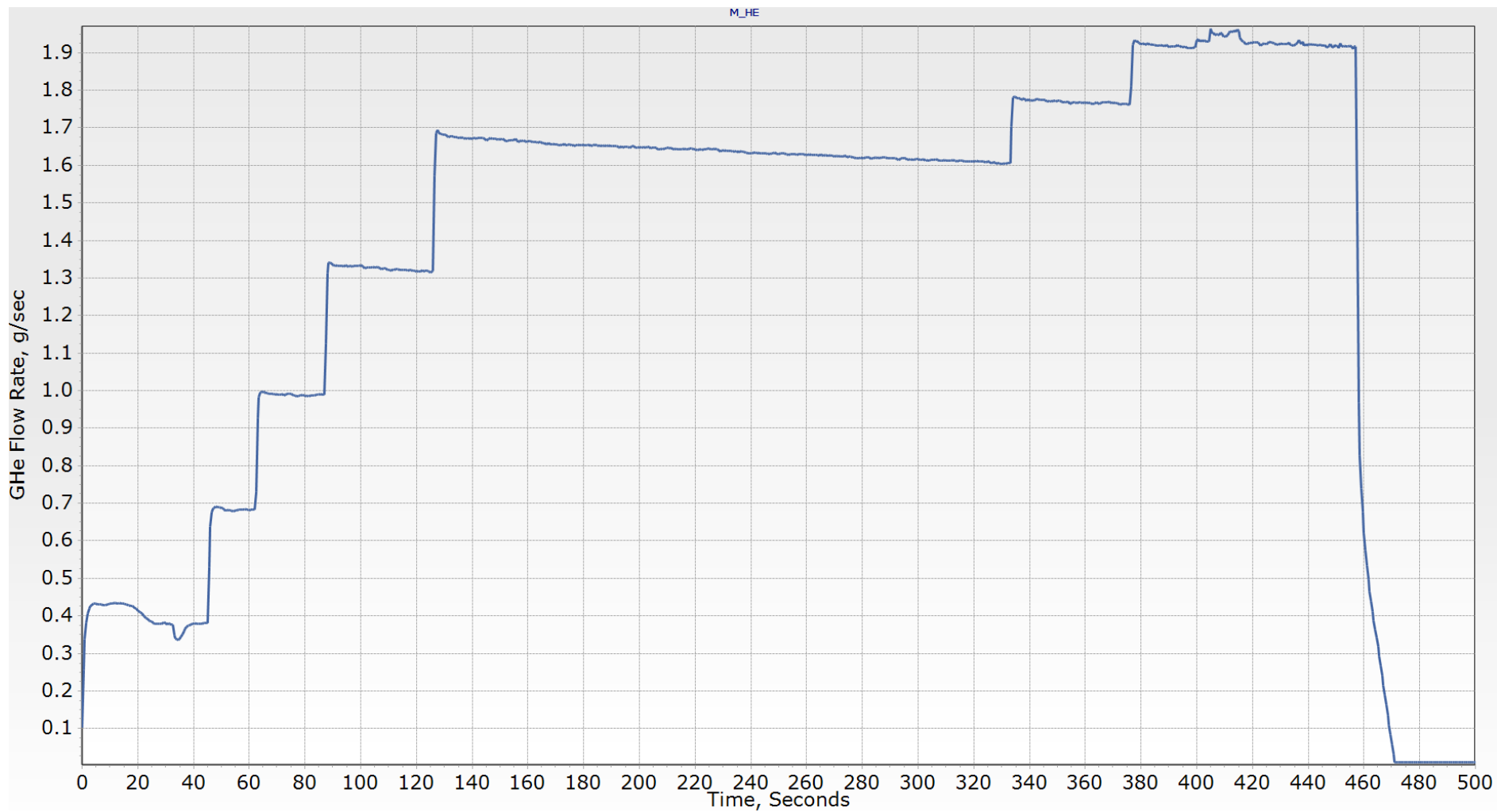



Predicted Pressure at Various Dissolution Rates vs Experimental (Slow Pressurization)

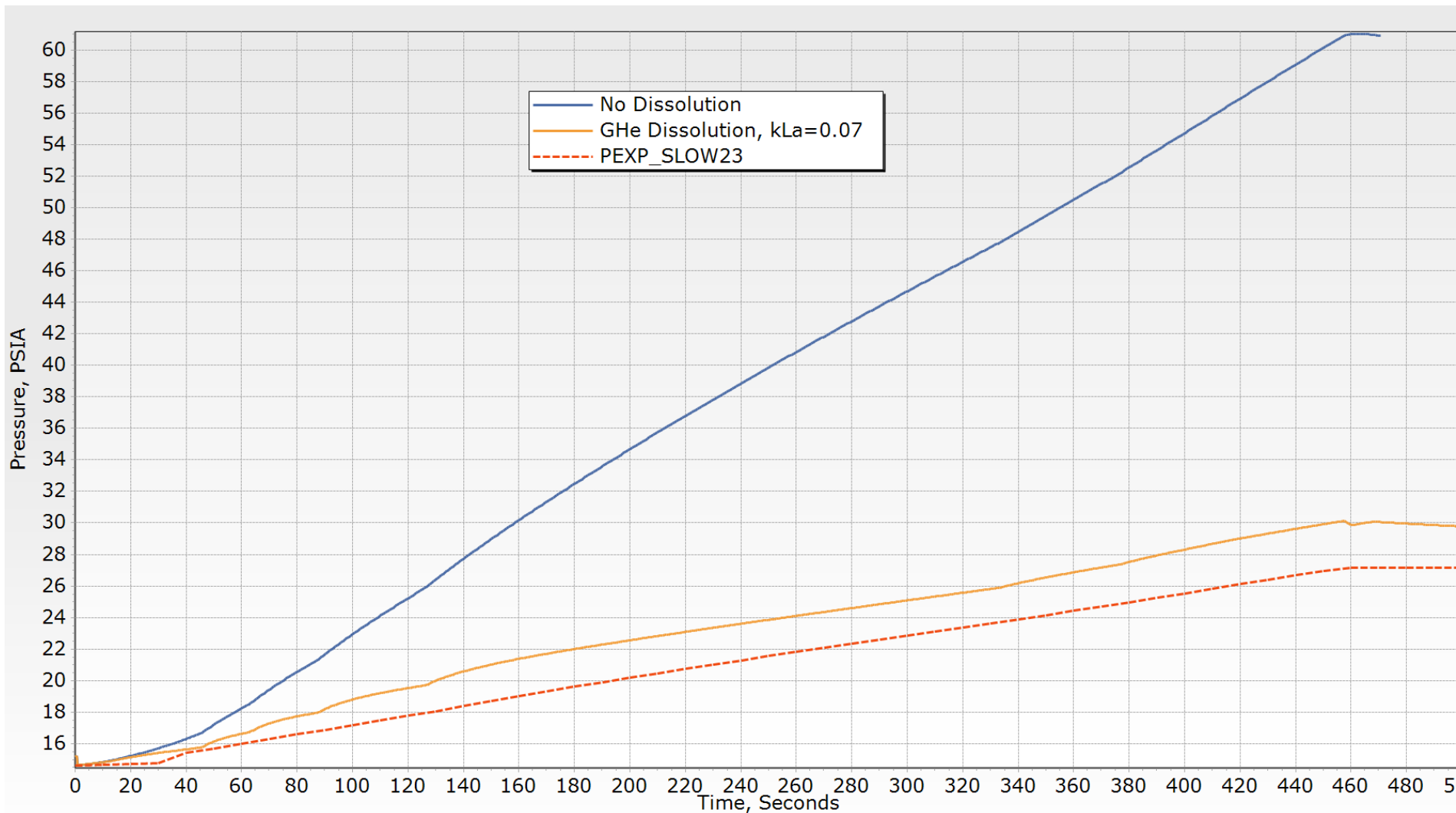



Bubble Modeling Notes to Consider for CFD Modeling



- When bubbles are produced in clouds such as the diffuser screen their behavior during rising is complicated by interaction among themselves.
 - Smaller bubbles will tend to coalesce and larger ones will disintegrate
- Rate of bubble rise has additional opposing influences that should be factored in when performing CFD modeling.
 - Chimney effect can develop in which a massive upward current appears at the axis of bubble stream, leading to increased net bubble velocity.
 - The proximity of the bubbles to one another can result in a hindered-settling condition leading to reduced velocity
- Further testing of diffuser with photography is necessary to investigate these effects.



Model Observations



- Simplified nodal model of submerged diffuser testing to observe model performance vs prediction and provide guidance for future CFD development.
- Empirical mass transfer correlations developed for bubble column applications including gas stripping processes predict significant helium dissolution.
- Thermal Desktop model matches experimental pressure significantly better when Helium dissolution is included into the model.
- This may imply that dissolution of GHe will be important to include into CFD model.
- Boiling at screen surface needs to be confirmed through diffuser visualization testing with screen surface temperature measurements.