

# Stirling Converter Controller Development at NASA Glenn Research Center

Presented by: Gina Dugala  
NASA Glenn Research Center  
Thermal Energy Conversion Branch

Wednesday, July 11, 2018

# Outline

- Background
- Stirling convertor controller functions
- Stirling convertors and support equipment
- Five controllers
- Controller testing
- Summary

# Background

- Existing Analog Controllers
  - Zener-diode controller and the Linear AC regulator controller
  - Uses tuning capacitors to passively correct the power factor.
- Existing Digital Controllers
  - Single Convertor Controller (SCC), Dual Convertor Controller (DCC), and Engineering Development Unit/Advanced Stirling Convertor Control Unit (EDU/ACU)
  - Digital controllers use field programmable gate arrays (FPGA) to implement control algorithms and other functionality.
  - Use power electronics to eliminate the need for tuning capacitors.
  - Pulse-width modulation switching of an h-bridge to control the convertors.
- The controllers were designed for use with a specific type of convertor but the same controller types can be modified to operate other types of convertors.

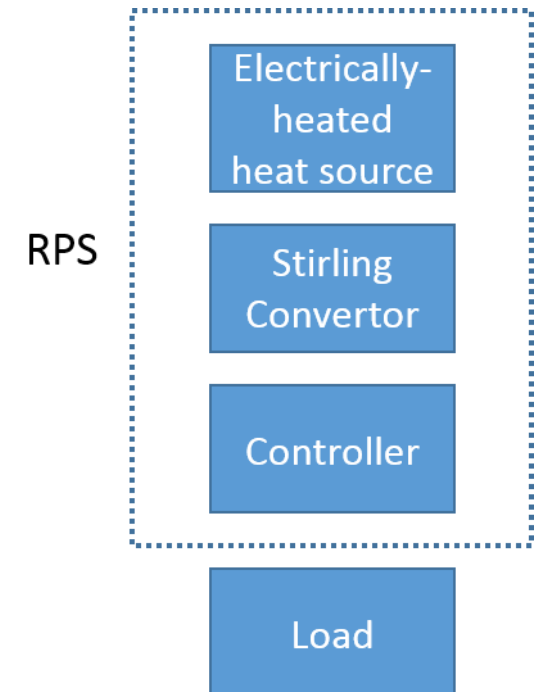

# Existing Analog Controller Functions

- Analog controller functions include:
  - Rectifying the power from the Stirling convertors from AC to DC.
  - Synchronizing the two convertors to reduce disturbance force.
  - Controlling the convertors' voltage (which then controls the piston amplitude).
- The analog controllers were not developed for flight/spacecraft integration but could be modified to meet flight requirements.

# Existing Digital Controller Functions

- Rectifying the power from the Stirling convertors from AC to DC.
- Synchronizing the two convertors to reduce disturbance force
- Controlling the convertors' operating frequency and voltage (which then controls the piston amplitude)
- Providing power to the spacecraft's DC power bus over a voltage range, with capability to handle over-voltage and under-voltage conditions
- Receiving and responding to commands from the spacecraft
- Providing telemetry to the spacecraft
- Incorporating fault management functionality at the controller box level and integrating into the spacecraft's fault management system.
  - When a fault is detected, control autonomously transfers from a primary controller to a backup controller.

# Stirling Convertors

- Different types of Stirling convertors have been developed to support various RPS projects at GRC.
- EE-35, Frequency Test Bed (FTB), and the Advanced Stirling Convertor (ASC) were developed by Sunpower, Inc.
- The Technology Demonstration Convertor (TDC) was designed by Stirling Technology Company (STC) which is now American Superconductor (AMSC).

	RMS Alternator Voltage (V)	RMS Alternator Current (A)	Alternator Power (W)	Operating Frequency (Hz)
TDC	85	0.8	65	82
EE-35	25	1.5	35	106.5
FTB	20	5	75	106
ASC-1	12	7	75	103
ASC-L	12	10	75	102.2
ASC-E3	18	6	75	102.2

# Dual Advanced Stirling Convertor Simulator (DASCS)

- The DASCS was designed by Johns Hopkins University/Applied Physics Laboratory (JHU/APL) in 2011 to support controller development.
- Simulates a pair of ASCs.
- **Purpose**
  - Used for pre-convertor checkout testing with a high fidelity simulator.
- **Benefits**
  - Controller testing with the DASCS has identified issues that could have caused damage to the ASCs if the testing was performed.
  - Reduces the start-up time required for operating ASCs.
- **Design**
  - Custom-designed circuits
  - Commercial equipment
  - Linearized ASC model implemented in a digital signal processor (DSP).
  - Convertor alternator inductance and resistance are represented by physical components with electrical properties similar to the actual alternator.

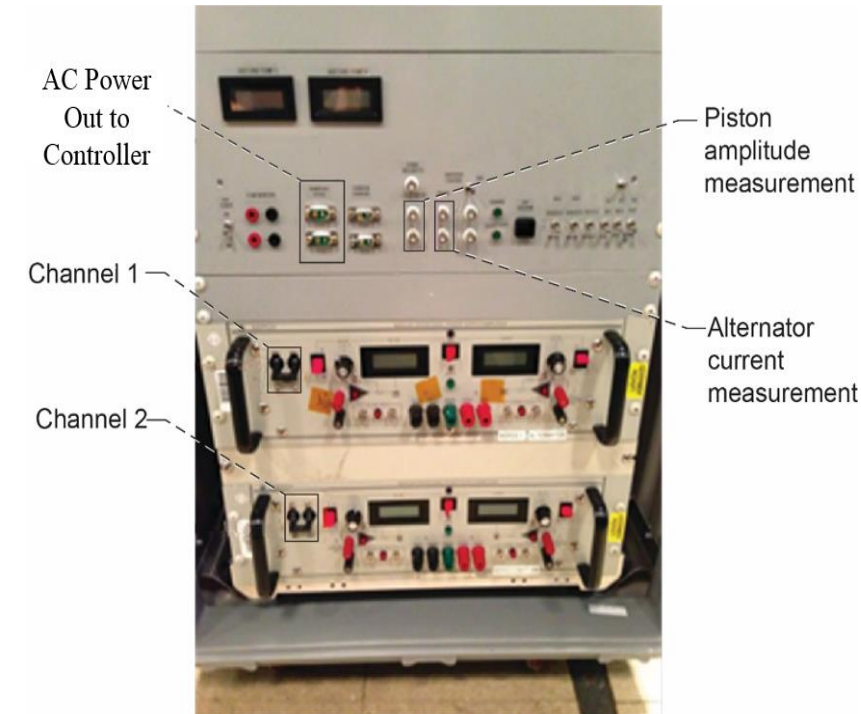

	RMS Alternator Voltage (V)	RMS Alternator Current (A)	Alternator Power (W)	Operating Frequency (Hz)
DASCS-12	12	7	75	103
DASCS-18	18	6	75	102.2

# Five Controllers



# Zener-Diode Controller



Zener-diode controller packaged for thermal vacuum.

Zener-diode controller.

- **Manufacturer/Designer**

- Originally designed by Stirling Technology Company (STC) which is now American Superconductor (AMSC).
- GRC modified the STC design, in 2003, to include additional functionality and rack monitoring.

- **Application**

- Supports laboratory operation.

- **Testing**

- A TDC version of the controller operates a pair of TDCs for over 100,000 hours.
- An ASC version of the controller operated a pair of ASCs in thermal vacuum for over 15,000 hours.

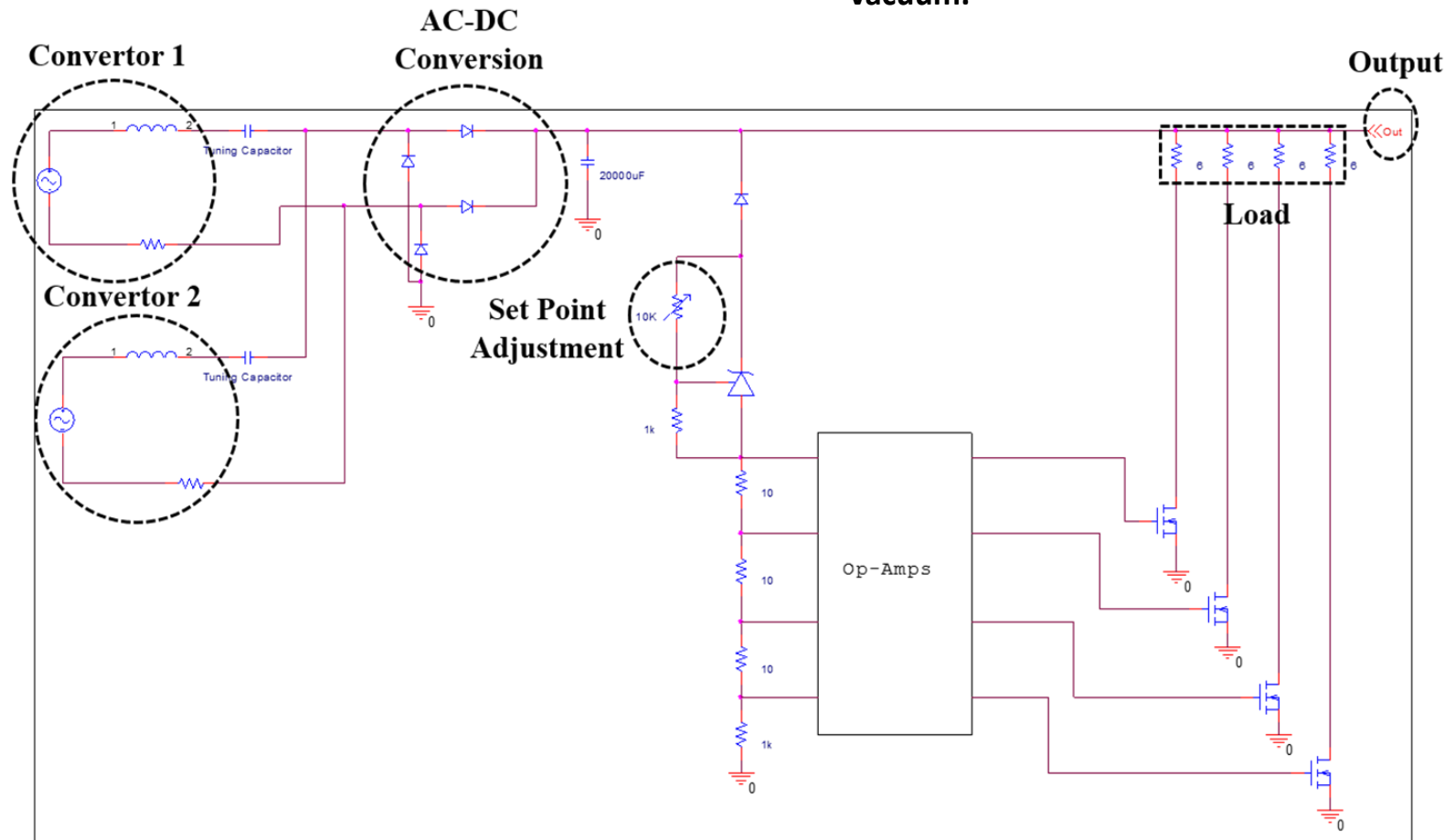

# Linear AC Regulator Controller

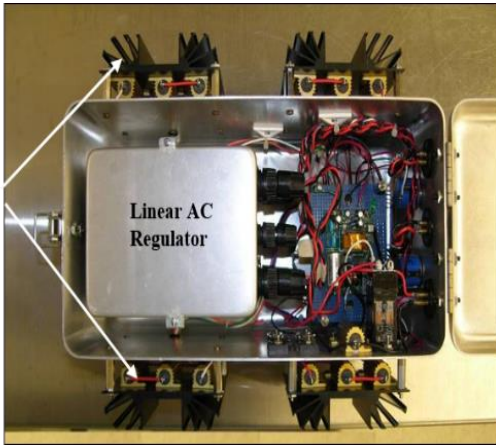

- **Manufacturer/Designer**
  - Designed in 2006 at GRC.
- **Application**
  - The Advanced Stirling Radioisotope Generator (ASRG) simulator mockup for a rover concept.
- **Testing**
  - Operated with the ASRG functional mockup.

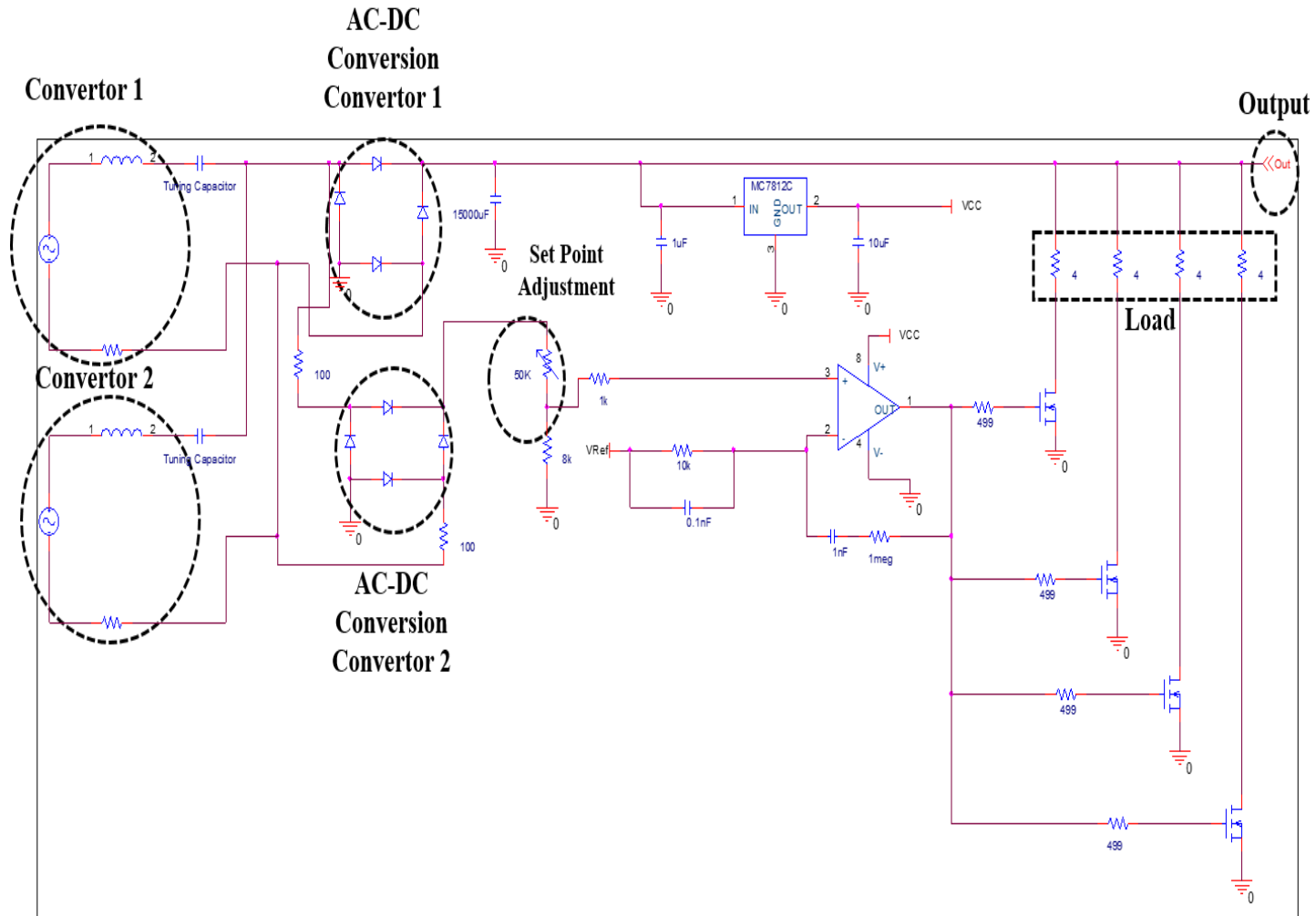

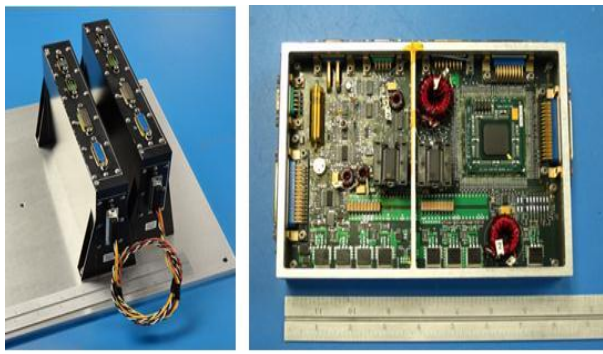

# Single Converter Controller (SCC)

## • Designer/Manufacturer

- JHU/APL delivered the SCC to GRC in 2011.

## • Application

- International Lunar Network (ILN) project – studied the feasibility of implementing a multiple-node seismometer network to investigate the internal lunar structure.
- Operates a single ASC, with an alternator voltage up to 15V, whereas the other controllers discussed operate a pair of ASCs.
- RS-422 communication
- Standby controller for fault tolerance.

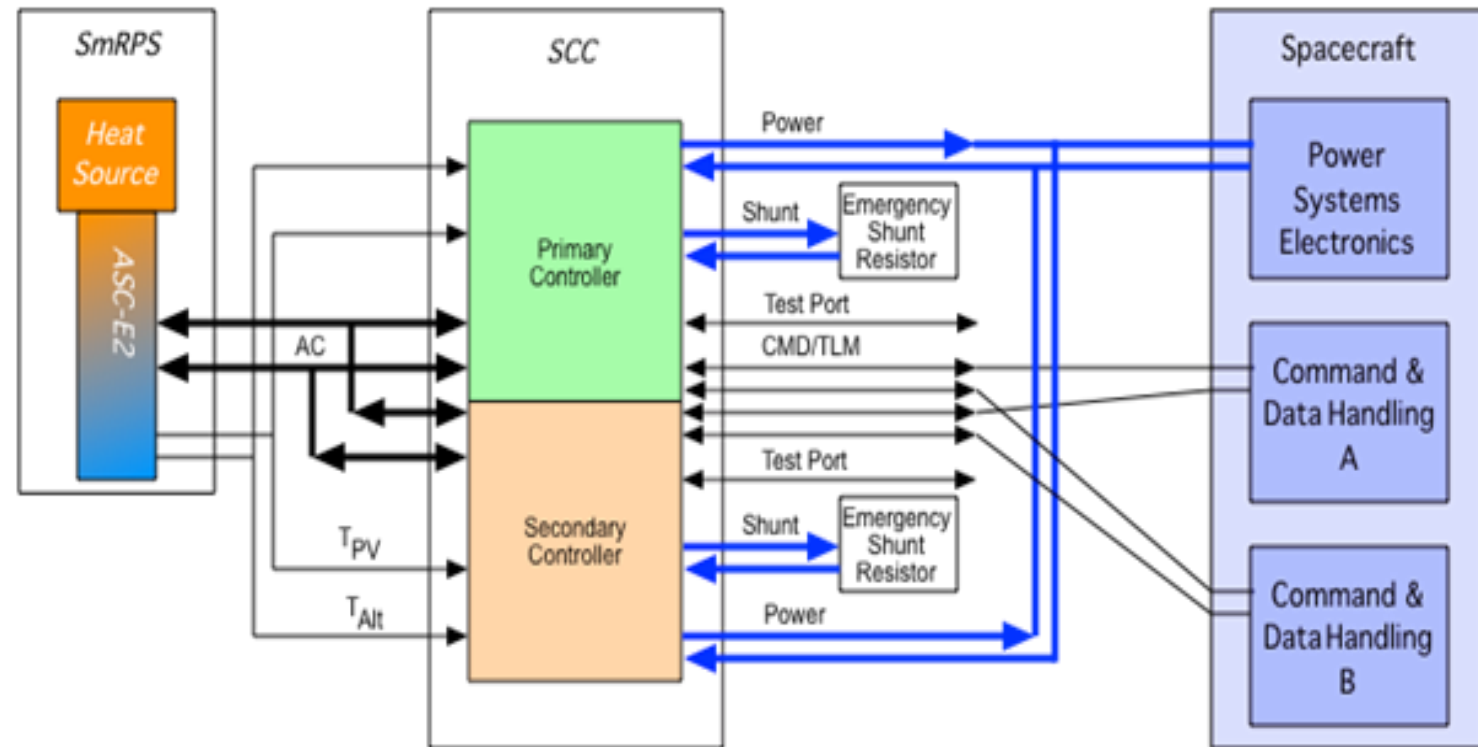

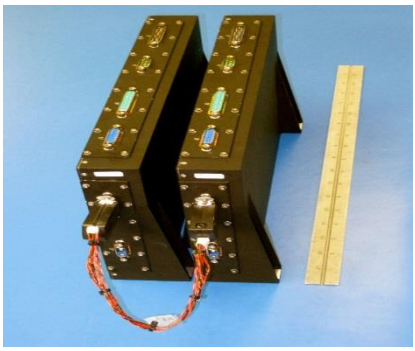

# Dual Converter Controller (DCC)

- Designer/Manufacturer
  - JHU/APL delivered the DCC to GRC in 2015.
- Application
  - Upgrade to the SCC.
- Operates ASCs with an alternator voltage up to 22 V.
- RS-422 communication
- One card controls both ASCs
- Standby controller for fault tolerance.

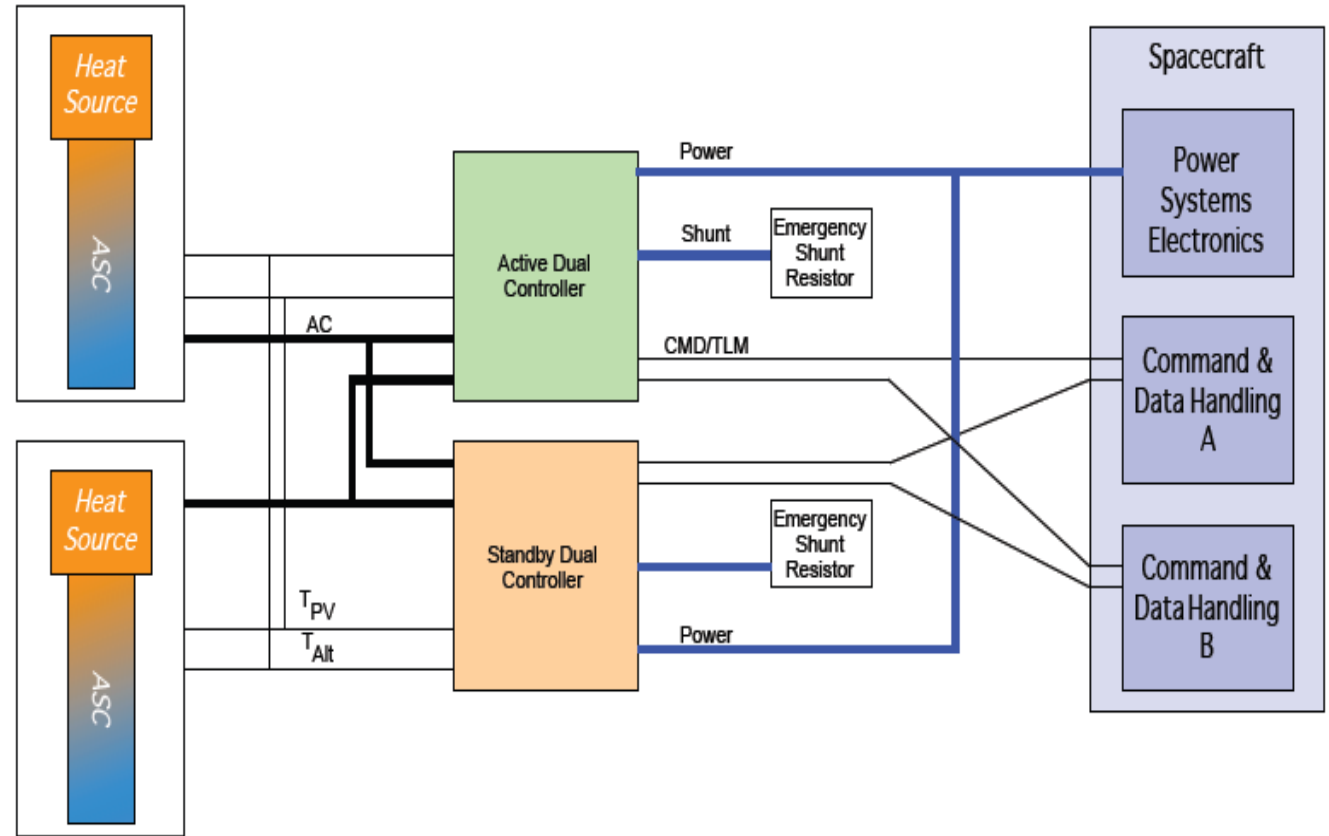

# Engineering Development Unit/Advanced Stirling Converter Control Unit (EDU/ACU)

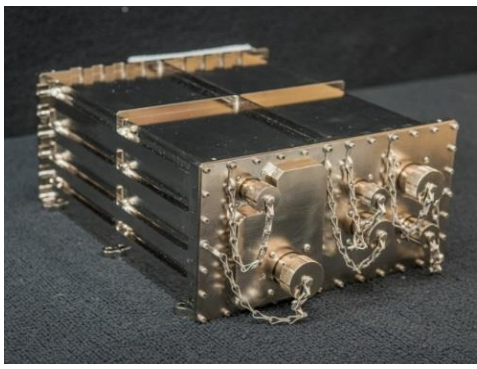

- Designer/Manufacturer
  - Lockheed Martin delivered the final version of the EDU/ACU in 2014.
- Application
  - ASRG
- Operates ASCs with an alternator voltage up to 22 V.
- MIL-STD-1553 communication
- One card per ASC.
- Standby controller card for fault tolerance.

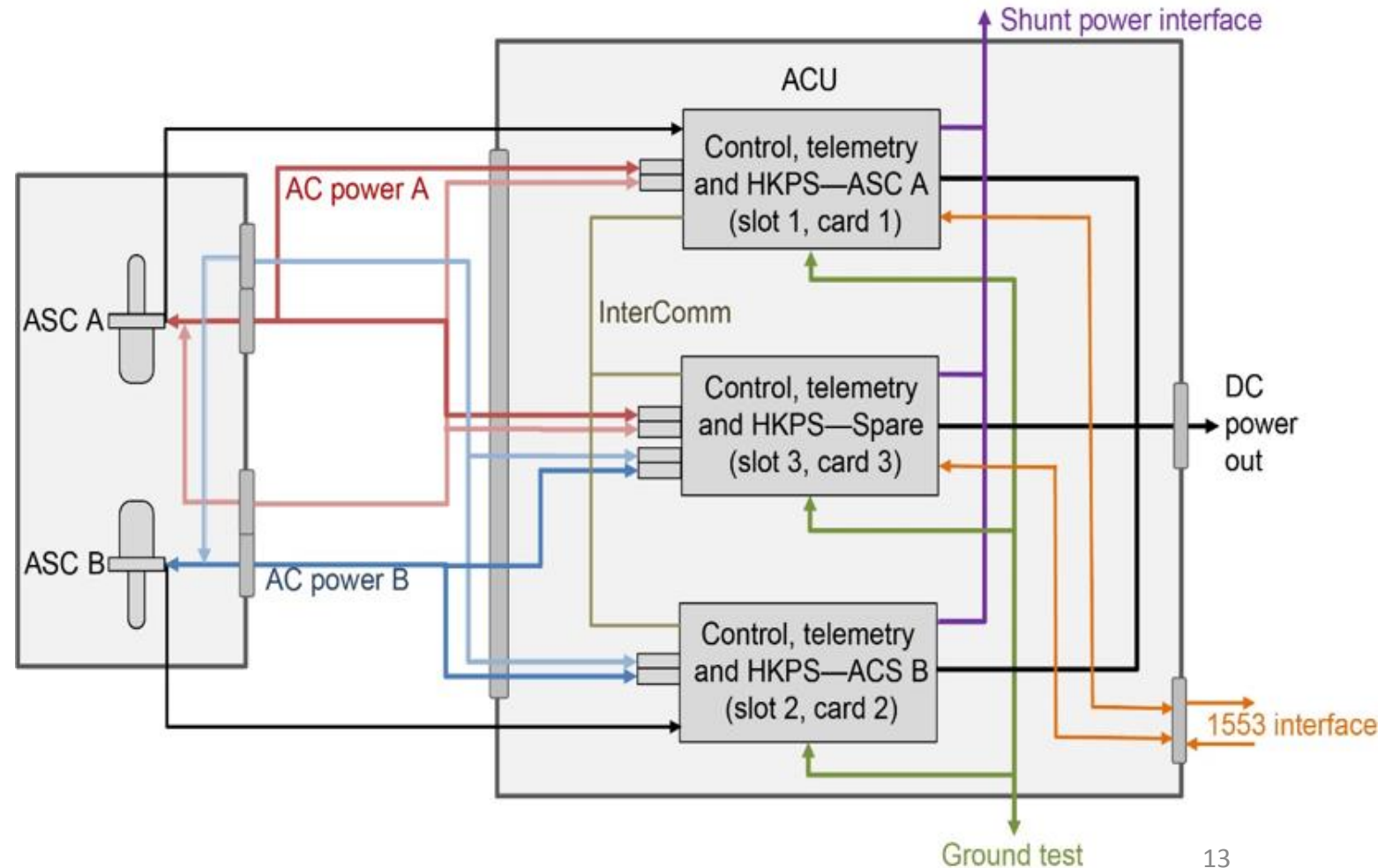

# Controller Testing

# Testing: Single Convertor Controller (SCC) and Dual Convertor Controller (DCC)

- **Electromagnetic Interference (EMI)**
  - AC and DC magnetic field – comparison of EMI signature with the SCC versus an off-the-shelf AC bus power supply. No difference in the EMI signature between the two methods of control.
  - Conducted emissions – large current component at twice the convertor operating frequency when tested with the SCC. To resolve this, a buck converter on the output of the DCC was used to reduce the current ripple to 5 mA.
  - Susceptibility – no noticeable performance effects during testing.
- **Flight acceptance vibration testing**
  - Qualification level was the goal but only flight acceptance level was achieved because the SCC was approaching current levels near its digitization range.
- **Fault testing**
  - Over/under the bus voltage range of 22-36 V.
  - H-bridge open/short
  - Emergency shunt open/short
  - Hot swap
  - The SCC and DCC successfully handled all the fault conditions.
- **Extended operation**
  - Operation with ASC-L for over 36,000 hours of operation as of June 2018.
  - Data is analyzed weekly and no changes in performance have been observed.

# RSIL: Background

- The Radioisotope Power Systems System Integration Laboratory (RSIL) was designed to simulate a prototypical spacecraft which is powered by an electrically-heated RPS with integration flexibility including multiple generators.
- Five major components:
  1. RPS power sources (a pair of ASCs)
  2. Power Management and Distribution (PMAD) system
  3. Energy storage system (bus capacitor, super capacitor, or battery)
  4. Electrical load simulators
  5. Flight control computer simulation
- Tests RPS generators as part of an end-to-end spacecraft system rather than as stand-alone power generators.

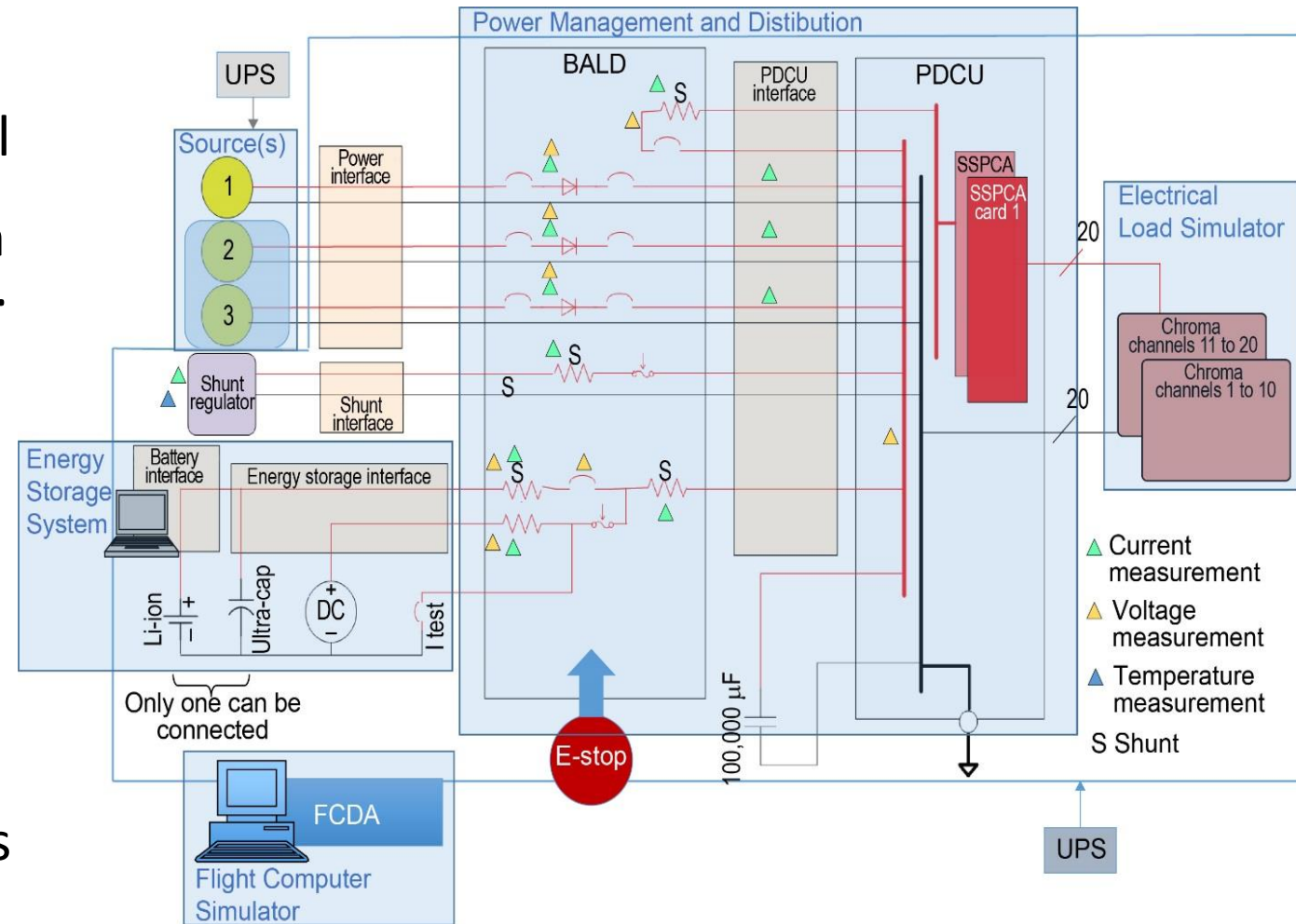



# Typical RSIL Tests

- **Load step**: 2A change in the spacecraft load
- **Load profile**: automated changes in load demand created based on several representative missions.
- **Over/under voltage**: verify the controller's ability to disconnect from RSIL when out of the 22-36V bus voltage range.
- **Short circuit**: Verify that the controller maintains operation of the convertors when the spacecraft load is shorted.

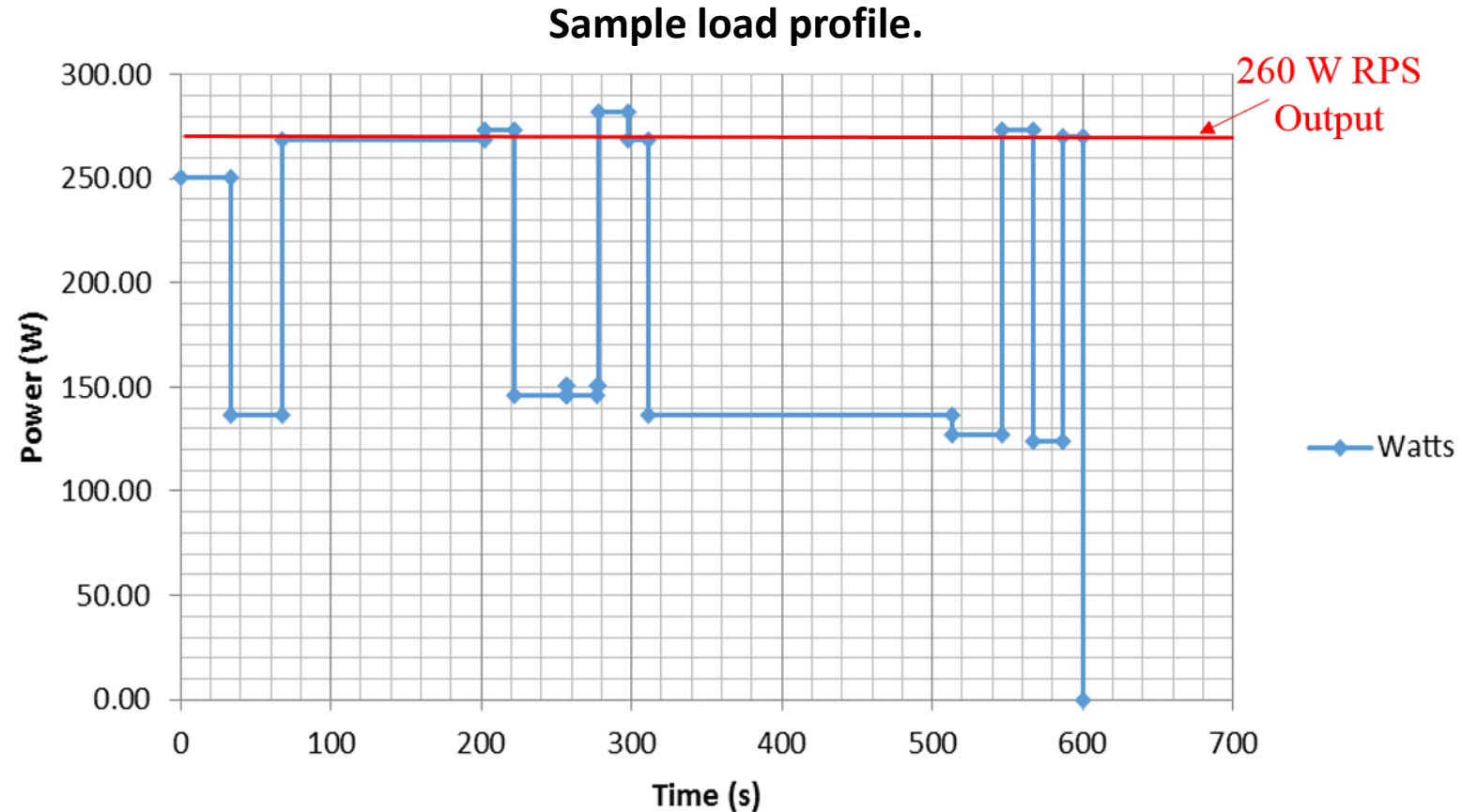

# Conclusion

- Several controller types developed as part of RPS technology development.
- Existing controllers were for laboratory testing and generator integration.
- Both analog and digital controller are being used and further developed.
  - Future tests planned for the SCC, DCC, and EDU/ACU
  - Development of a more flight-like analog controller has been started. The initial version of the design has been tested with a single TDC.

# Summary of Five Controllers

	Zener-Diode	Zener-Diode	Linear AC Regulator	SCC	ACU	DCC
<b>Design/Manufacturer</b>	GRC/STC	GRC	GRC	APL	LMCT	APL
<b>Type of Convertor</b>	TDC	ASC	ASC	ASC	ASC	ASC
<b># of Convertors</b>	2	2	2	1	2	2
<b>Tuning Cap</b>	Yes	Yes	Yes	No	No	No
<b>Fidelity</b>	Prototype	Prototype	Prototype	Engineering Model	Engineering Model	Engineering Model
<b>Set Point Control</b>	Potentiometer	Potentiometer	Potentiometer	RS-422	MIL-STD-1553	RS-422
<b>Telemetry</b>	No	No	No	Yes	Yes	Yes
<b>Analog/Digital</b>	Analog	Analog	Analog	Digital	Digital	Digital
<b>Spacecraft Bus Voltage Range</b>	N/A	N/A	N/A	22-36	22-34	22-36
<b>Extended Operation</b>	>110,000	>15,000	No	>36,000	2,000	No
<b>Delivered</b>	2003	2006	2007	2011	2014	2015
<b>AC Input Voltage</b>	Up to 80V	Up to 12 V	Up to 12 V	Up to 15 V	Up to 22 V	Up to 22 V
<b>Application</b>	Laboratory – air	Laboratory – thermal vacuum	ASRG simulator	ILN	ASRG	SCC upgrade

# RSIL Testing: DCC and EDU/ACU

- **Test sequence**

- Operate with a DASCs to verify the functionality of both the DCC and RSIL on one RSIL channel
- Integrate with a pair of ASC-1s on one RSIL channel
- Operate with two DASCs operating as parallel inputs (channel 1 and 2) to RSIL.

