

USING GPS RECEIVER 1PPS OUTPUT TO VERIFY TIME STAMP ACCURACY AND MEASURE PROPAGATION DELAY

Kevin Knudtson

**NASA Armstrong Flight Research Center
Edwards, California 93523**

Antonio Moreno

**Arcata Associates Inc.
NASA Armstrong Flight Research Center
Edwards, California 93523**

ABSTRACT

A simple pulse overlay circuit using a logic OR gate was developed to overlay a precise leading edge 1 pulse per second time reference marker from a global positioning system receiver onto a non-return -to- zero-level pulse code modulation telemetry data stream to validate time stamp accuracy and measure propagation delay in telemetry equipment.

KEYWORDS

Time stamp offset; Propagation delay; 1PPS; Test measurement

NOMENCLATURE

DA	distribution amplifier
DAU	distribution amplifiers unit
GPS	global positioning system
OS	one-shot
OC03	optical carrier level three
OTDR	optical time domain reflectometer
PCM	pulse code modulation
PD	propagation delay
PO	pulse overlay
PRN11	pseudo random number 11
RTC	real time counter
VDA	video distribution amplifiers
VDC	voltage direct current
VPW	variable pulse width
VR1	variable resistor one

1PPS

one pulse per second

INTRODUCTION

A pulse overlay (PO) circuit was designed to produce a time reference marker within a pulse code modulation (PCM) telemetry data stream that was recorded and analyzed to validate an IRIG Standard 106-17 Chapter 10 recorder's time stamp accuracy [1]. A manufacturer of a newly purchased Chapter 10 recorder claimed the time stamp accuracy to be better than 10 microseconds (μs) with only IRIG-B120 (IRIG-B) input and better than 1 μs with IRIG-B and one pulse per second (1PPS) inputs. The PO circuit and a Chapter 10 recorder test setup were used to verify the vendor's data-time synchronization claims and to justify infrastructure upgrade costs to connect additional cables to each purchased recorder. The circuit was also used to measure the propagation delay (PD) of a long distance Telemetry multiplexer/demultiplexer telecommunication system which the manufacturer did not provide a PD specification.

CIRCUIT DESIGN

The PO circuit is shown in Figure 1. The 1PPS signal of the global positioning system provides a 20 μs pulse with the leading edge being within 100 nanoseconds (ns) of a second mark. The 1PPS signal is processed using the one-shot (OS) multivibrator 74LS123 [2, 3] chip (Texas Instruments, Dallas, Texas) to adjust the 1PPS pulse width from 10 μs to 110 μs with a maximum delay of 32 ns. The adjusted signal is called 1PPS variable pulse width (VPW). This signal provides a flexible method to create a unique signal or test data pattern that is easily observed on an oscilloscope or within processed data. The 1PPS VPW signal is logically OR-ed within the 74LS32 [4] chip (Texas Instruments, Dallas, Texas) to overlay the 1PPS VPW signal into a PCM telemetry data stream. The final modified PCM telemetry data output is used to measure and analyze time synchronization of processed or transported telemetry data within an operational environment.

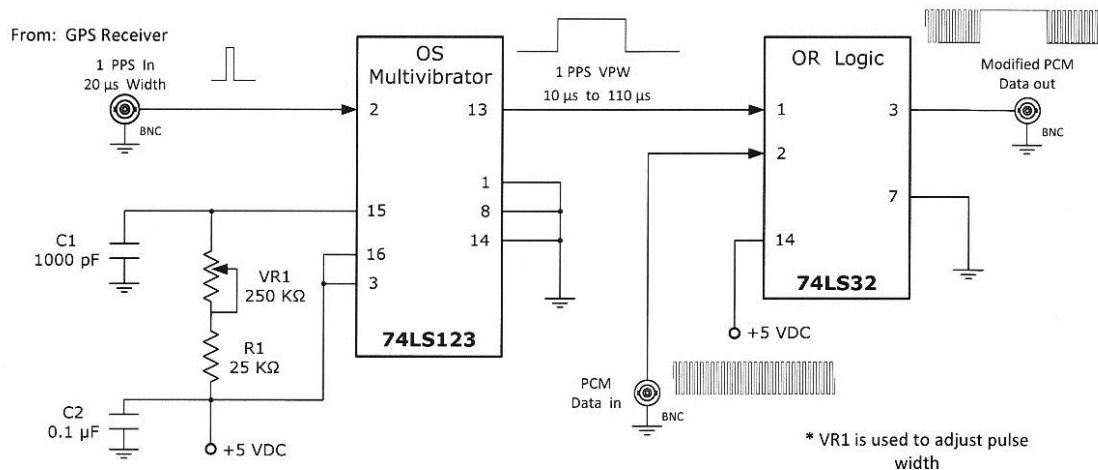

Figure 1. Pulse Overlay Circuit.

CHAPTER 10 RECORDER TEST SETUP

The Chapter 10 recorder test setup is shown in Figure 2. The GPS receiver provides a standard IRIG-B and 1PPS time signals that are connected to the distribution amplifiers unit (DAU) to distribute conditioned signals to the tested Chapter 10 recorder and the PO circuit. The Chapter 10 recorder was tested with IRIG-B only and then tested with IRIG-B and 1PPS as time input signals. The output of the PO circuit provides the modified PCM data with an overlaid 1PPS VPW precise time reference marker. The video distribution amplifiers (VDA) and the DAU are used to optimize signal levels with negligible ~14 ns propagation delay for each amplifier.

A serial telecommunication test set was used as the PCM telemetry data source. This test set generated a PCM data and clock telemetry stream with a pseudo random number 11 (PRN11), also known as 2047 pseudo random bit sequence to emulate a random telemetry data stream [5]. The PCM clock signal is synchronized to PCM data bits for receiving equipment to correctly process each PCM data bit.

The following is the tested recorder setup:

Chapter 10 PCM packet: 16-bit aligned packed mode

Bit rate = 2.5 Mb/s

PCM sync pattern: 0x805022

Data word length: 12 bits

Words/minor frame: 2047

Bits/minor frame; 24576 total = 24564 + 12 filler bits to align data to a 16-bit boundary

Minor frames/Chapter 10 PCM packet: 2

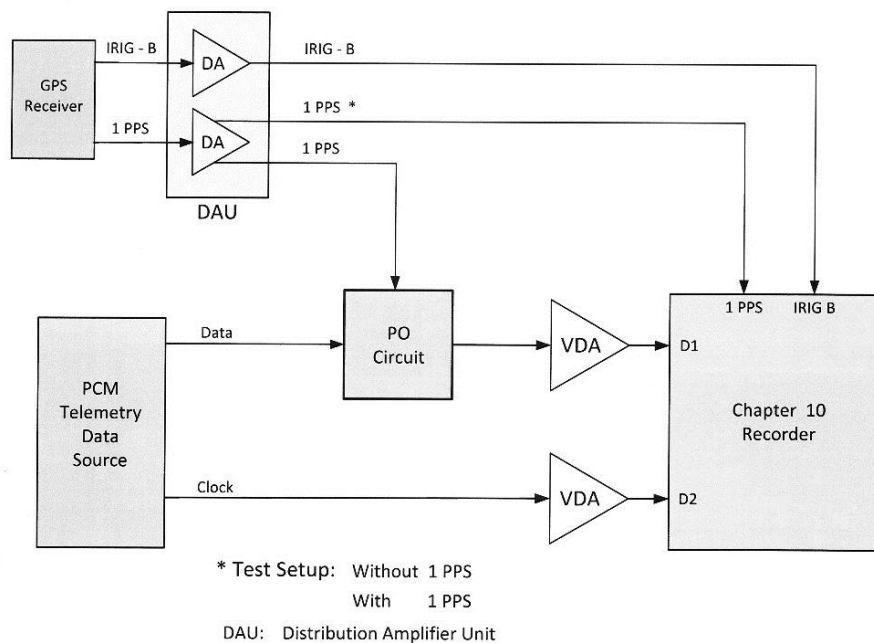

Figure 2. Chapter 10 Recorder Test Setup Used to Verify Time Stamp Accuracy.

CHAPTER 10 RECORDER TIME STAMP OFFSET TEST METHODOLOGY

A Chapter 10 packet viewer was used to read the recorded Chapter 10 file PCM data in a hex format and to read the time stamp for the 1st PCM data bit within the packet. The Chapter 10 recorder uses the IRIG-B and optional 1PPS time signals to correlate the Chapter 10 internal 10 MHz real time counter (RTC) with the on the second IRIG-B time data. The information is recorded within a Chapter 10 time packet. The Chapter 10 recorder then synchronizes PCM data to time by recording an updated RTC value for the 1st PCM data bit within each PCM packet. One RTC increment represents 100 ns of time. This 1st PCM data bit time stamp is needed to calculate the time stamp for the 1st bit of the overlaid 1PPS VPW data sequence.

The packet viewer was also used to find Chapter 10 packets containing and not containing the overlaid 1PPS VPW data sequence. A clean PRN11 sequence data pattern was collected and saved to precisely identify the actual 1st 1PPS VPW data bit within a Chapter 10 packet. A Chapter 10 packet containing the overlaid 1PPS VPW data sequence will have the 1st PCM data bit time stamp near a second mark. The displayed PCM data set within the packet viewer was then copied and pasted into a text editor to verify the presence of the unique 1PPS VPW data sequence pattern of “FFF,” (Table 1). The clean PRN11 data pattern sequence cannot have more than 11 consecutive 1s, so searching for “FFF” is enough to find the approximate beginning of the full unique 1PPS VPW data pattern.

The main analysis for calculating the time stamp for the 1st 1PPS VPW data bit is to count the number of bits between the 1st PCM data bit and the 1st 1PPS VPW data bit, and divide this count by the PCM bit rate to produce a 1PPS delta time offset that is added to the Chapter 10 1st PCM data bit time stamp (see the following formulas for more details).

Table 1. Relationship Between 1PPS Pulse Width and Possible Hex Patterns.

The unique 1PPS VPW signal produces a consecutive 1s data pattern. The relationship between a 1PPS VPW pulse width and PCM bit rate will produce different lengths of consecutive 1s. The consecutive 1s pattern can be viewed as hex and may have possible patterns starting 0x1, 0x3, 0x7, 0xF and ending with 0xE, 0xD, 0xC, or 0x8.			
Data rate	1PPS pulse width	Number of consecutive 1s bits	Example hex patterns
1.0 Mbps	20 μs	20	FFFF F or 1FFF FE or 7FFF F8
2.5 Mbps	20 μs	50	FFFF FFFF FFFF C
4.0 Mbps	20 μs	80	3FFF FFFF FFFF FFFF FFFF C

Formulas to Calculate 1PPS Time Stamp:

The following are the variable names and descriptions used in the formulas:

- 1PPS_time = Calculated time stamp for 1st bit of 1PPS VPW
- mF_time = Packet viewer’s reported time stamp for 1st PCM data bit
- DB = Packet viewer’s reported byte address nearest to the 1st 1PPS VPW data bit
- IPH = Intra-packet data header size = 80 bits
- Db = Additional bits offset to the 1st 1PPS VPW data bit
- Filler = Recorder added bits to end packet on a 16-bit boundary = 12 bits
- br = PCM data bit rate = 2.5 Mb/s

The setup of the Chapter 10 recorder will record two minor frames of telemetry PCM data within each Chapter 10 PCM packet, so there are 2 formulas to consider in calculating the time stamp of the 1st 1PPS VPW data bit. The decision point for selecting the correct formula is based on the byte offset for the 1st 1PPS VPW data bit. If the byte offset is greater than 0x0C0A, Formula#2 accommodates the subtraction of 12 filler bits from the first minor frame and subtracts another 80 IPH bits from the second minor frame. The 0x0C0A decision point is derived from (80 IPH bits + 24,576 bits per minor frame)/8 bits = 3082 bytes = 0x0C0A.

Formula#1 - 1st bit of 1PPS VPW byte address is “less” than 0x0C0A:

$$1PPS_time = mF_time + (DB * 8 \text{ bits} - IPH + Db) / br$$

Formula#2 - 1st bit of 1PPS VPW byte address is “greater” than 0x0C0A:

$$1PPS_time = mF_time + (DB * 8 \text{ bits} - IPH + Db - \text{Filler} - IPH) / br$$

Test#1 Example - Calculated Results with Only IRIG-B Time Input:

The analysis example below has its results defined within Table 2 as bold text. The Chapter 10 packet containing the 1PPS VPW data pattern has a time stamp of 077:20:55:03.998354 for the 1st PCM data bit. The PCM packet data set was copied into a text editor to search for the unique “FFF” data pattern and verify the location of the 1st 1PPS VPW data bit. The saved standard PRN11 data set was then used to precisely identify the actual 1st 1PPS VPW data bit (see Table 2 for the total of 12 calculated results from this test group).

The following shows the values for the variable names used in the formula:

mF_time = 077:20:55:03.998354 – Time stamp for 1st data bit within the PCM packet
 br = 2.5 Mb/s
 DB = 0x20A or 522 bytes – Formula#1 used because byte address < 0x0C0A
 IPH = 80 bits for 16 bit aligned packed mode
 Db = 0 bit – see packet data below where “FFFF” byte address is **0x20A**

Formula#1 used to calculate the time stamp of the 1st 1PPS VPW:

$$1PPS_time = 077:20:55:03.998354 + (522 \text{ bytes} * 8 \text{ bits} - 80 \text{ bits} + 0) / 2.5 \text{ Mbs}$$

$$1PPS_time = \sim 077:20:55:03.9999924 = 077:20:55:03.998354 + 0.0016384$$

1st 1PPS VPW data bit time stamp is offset by **~7.6 μs** (early) or 19 bits offset

The following shows the shortened Chapter 10 PCM packet data for review:

Packet data: [- intra-packet header (IPH) -] || -1st PCM data bit is 1000₂

00000000	E29F 9350 0004 0000 F000 8050 2215 480D
00000010	0723 75D4 50A2 456A 184F 2E72 F725 7615
Byte	*
Address	Normal PRN11 hex sequence:--- 0140 8855 2174
Offset	* 0x20A – bytes offset
00000200	FC61 BCE9 E9C9 DDD5 5002 FFFF FFFF FFFF
00000210	DC8D D751 4289 15A8 613C B9CB DC95 D857

Table 2. Analyzed Results of Recorded Chapter 10 Data with Only IRIG-B Connected.

Bytes offset hex	Bits offset	1st PCM bit time	1pps delta time, s	1st 1PPS bit time	Time off, μ s
1360	11	077:20:51:29.984184	0.0158076	077:20:51:29.9999916	8.40
0A44	10	077:20:51:59.991612	0.0083816	077:20:51:59.9999936	6.40
0134	0	077:20:52:29.999038	0.0009536	077:20:52:29.9999916	8.40
12DF	0	077:20:52:58.984602	0.0153904	077:20:52:58.9999924	7.60
11E8	3	077:20:53:25.985392	0.0146012	077:20:53:25.9999932	6.80
0C6F	3	077:20:53:57.989874	0.0101180	077:20:53:57.9999992	8.00
0353	0	077:20:54:27.997302	0.0026912	077:20:54:27.9999932	6.80
1249	7	077:20:54:57.985078	0.0149132	077:20:54:57.9999912	8.80
020A	0	077:20:55:03.998354	0.0016384	077:20:55:03.9999924	7.60
092D	3	077:20:55:27.992505	0.0074860	077:20:55:27.9999991	9.00
001C	5	077:20:55:57.999932	0.0000596	077:20:55:57.9999916	8.40
0C60	5	077:20:56:28.989921	0.0100708	077:20:56:28.9999918	8.20
Average time offset					7.87

Test#2 Example - Calculated Results with IRIG-B and 1PPS Time Inputs:

The analysis example below has its results defined within Table 3 as bold text. The Chapter 10 packet containing the 1PPS VPW data pattern has a time stamp of 077:20:43:55.983476 for the 1st PCM data bit. The PCM packet data was copied into a text editor to search for the unique “FFF” data pattern and verify the location of the 1st 1PPS VPW data bit. The saved standard PRN11 data set was then used to better estimate the actual 1st 1PPS VPW data bit (see Table 3 for the total of 12 calculated results from this test group).

The following shows the values for the variable names used in the formula:

- mF_time = 077:20:43:55.983476 – time stamp for 1st data bit within the PCM packet
- br = 2.5 Mb/s
- DB = 0x1441 or 5185 bytes – Formula#2 used because byte address > 0x0C0A
- IPH = 80 bits for 16 bit aligned packed mode
- Db = 0 bit– see packet data where “84FF” byte address is **0x1441**

Formula#2 used to calculate the time stamp of first 1st 1PPS VPW:

$$1PPS_time = 077:20:43:55.983476 + (5185 \text{ bytes} * 8 \text{ bits} - 80 \text{ bits} + 0 - 12 \text{ bits} - 80 \text{ bits}) / 2.5 \text{ Mb/s}$$

$$1PPS_time = \sim 077:20:43:55.9999992 = 077:20:43:55.983476 + 0.0165232$$

1st 1PPS VPW data bit time stamp is offset by **~800 ns** (early) or 2 bit offset

The following shows the shortened Chapter 10 PCM packet data for review:

Packet data: [-intra-packet header (IPH) -] ||-- 1st PCM data bit is 1000₂

00000000	EA31 0525 0003 0000 F000 8050 2215 480D
00000010	0723 75D4 50A2 456A 184F 2E72 F725 7615

Byte address *

Address 8472 B70D 671F 6C5B - normal hex sequence

Offset * || **0x1441** – bytes offset with 1st 1PPS data bit is 1111₂

00001440	84FF FFFF FFFF FFDB A6A7 8733 7FD0 120B
00001450	44CA FC21 94F8 E36D DB56 C1B8 EB68 D977

Table 3. Analyzed Results from Recorder Test with IRIG-B and 1PPS Connected.

Bytes offset hex	Bits offset	1st PCM bit time	1PPS delta time, s	1st 1PPS bit time	Time off, μ s
08F3	6	077:20:42:57.992699	0.0073016	077:20:42:58.0000006	-0.60
0549	3	077:20:43:25.995701	0.0042988	077:20:43:25.9999998	0.20
1441	0	077:20:43:55.983476	0.0165232	077:20:43:55.9999992	0.80
00FB	0	077:20:44:11.999228	0.0007712	077:20:44:11.9999992	0.80
0B24	5	077:20:44:25.990904	0.0090964	077:20:44:26.0000004	-0.40
0D1D	4	077:20:44:55.989324	0.0106752	077:20:44:55.9999992	0.80
0400	7	077:20:45:25.996752	0.0032476	077:20:45:26.9999996	0.40
12F8	4	077:20:45:55.984528	0.015472	077:20:45:56.0000000	-0.00
14E6	1	077:20:46:25.982949	0.0170512	077:20:46:26.0000002	-0.20
0BC9	4	077:20:46:55.990375	0.009624	077:20:46:55.9999999	1.00
02B8	5	077:20:47:25.997803	0.0021972	077:20:47:26.0000002	-0.20
0759	4	077:20:47:54.994011	0.0059888	077:20:47:54.9999998	0.20
Average time offset					0.23

Summary of Chapter 10 Recorder Test Results:

Test results from Chapter 10 recorder test#1 with IRIG-B only has an average offset time of **~7.87 μ s** (early) and the test results of Chapter 10 recorder test#2 with IRIG-B and 1PPS has an average offset time of **~0.23 μ s** (late). The two tests successfully verified the vendor's claim and justified the implementation to add the 1PPS signal to the range Chapter 10 recorders.

PROPAGATION DELAY SETUP AND MEASUREMENTS

The PO circuit was also used to measure the PD of an entire optical carrier level 3 (OC-3) multiplexer/demultiplexer system within its normal operational environment (see Figure 3 for test setup). This measurement was needed since the manufacturer did not provide a written PD specification. Using an optical time domain reflectometer (OTDR) would only measure the fiber link.

The test setup with PO circuit provided a simple PD measurement of the entire OC-3 system that included video distribution amplifiers, patch panels, and cables. The 1PPS signal of the GPS receiver provided a solid trigger on the oscilloscope. The oscilloscope cursors were used to measure PD between the sent/return 1PPS VPW signals. The measured PD round-trip was 12.22 milliseconds, which translates to a one-way PD of 6.11 milliseconds. These test results matched with the vendor's verbal specification of 3 milliseconds PD per OC-3 unit.

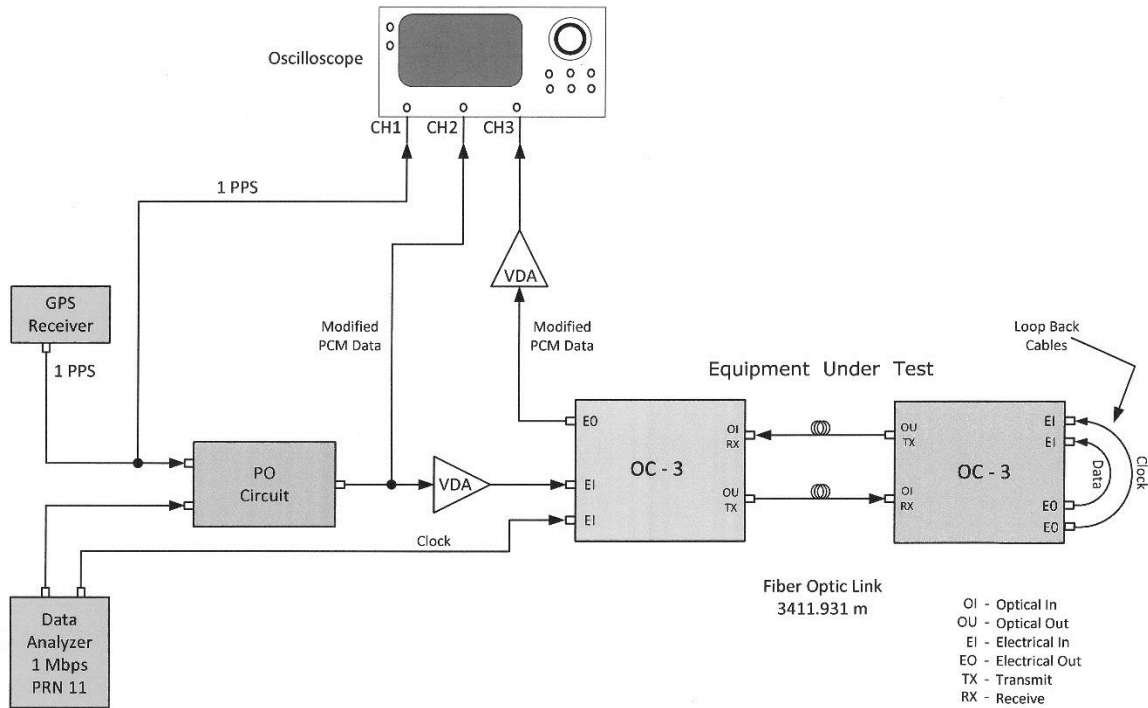

Figure 3. Propagation Delay Measurements Block Diagram.

CONCLUSION

Using the one pulse per second time reference marker of the global positioning system receiver and the pulse overlay circuit to overlay the one pulse per second variable pulse width signal into a pulse code modulation telemetry stream provided an excellent means to validate time stamp accuracy within a Chapter 10 recorder and to measure propagation delays within a normal telemetry operating environment. The positive results from the Chapter 10 recorder tests validated the vendor's claims and justified the implementation to add the one pulse per second signal to the range Chapter 10 recorders. The pulse overlay circuit and test setups defined in this paper can easily be used to measure other telemetry equipment.

REFERENCES

- [1] *Telemetry Standards, IRIG Standard 106-17*, Range Commanders Council, US Army White Sands Missile Range, New Mexico, Chapter 10, July 2017.
- [2] Floyd, Thomas L., Digital Fundamentals, 3rd ed., Charles E. Merrill Publishing Company, Columbus, Ohio, 1986.
- [3] Texas Instruments Incorporated, “Designing with the SN54/74LS123,” Dallas, Texas, 1997. (Available on-line at <http://www.ti.com/lit/an/sdla006a/sdla006a.pdf>).
- [4] Texas Instruments Incorporated, “SN74LS32, Quadruple 2-input positive-Or gates,” Dallas, Texas, December 1983, revised March 1988. (Available on-line at <http://www.ti.com/lit/ds/sdls100/sdls100.pdf>).
- [5] International Telecommunication Union, “Digital Test Patterns for Performance Measurements on Digital Transmission Equipment,” O-150, October 1992.