

Development of a direct fabrication technique for full-shell x-ray optics

M. Gubarev¹, J.K.Kolodziejczak¹, C. Griffith, J. Roche, W. S. Smith¹, T. Kester¹,
C. Atkins², W. Arnold³ and B. Ramsey¹

¹NASA Marshall Space Flight Center, Huntsville, AL, USA

²University of Alabama at Huntsville, Huntsville, AL, USA

³A. I. Solutions, Inc., Huntsville, AL, USA

X-ray Optics after Chandra



The challenge is to develop optical fabrication technology capable of producing x-ray optics with high angular resolution but with an order of magnitude lighter mirrors and at an affordable price.

The challenge can be approached from different directions:

- Very thin mirrors (0.2-0.4 mm):
 - Replicated optics
 - Pore Optics
 - Figure Correction
- Intermediate thickness mirror (0.5-2.0 mm):
 - Direct fabrication, Chandra-like
 - Figure corrections can be applied too



Direct Fabrication

Material	Density (g/cm ³)	CTE (10 ⁻⁶ / K ⁻¹)	Elastic Modulus GPa	Yield Strength MPa
Fused Silica	2.2	0.5	72	48*
Beryllium	1.8	12	318	240
BeAL-162MET	2.1	24	69	276
AlSi	2.8	13.9	193	314
Duralcan F3S.30S AlSi+SiC(30% by vol)	2.8	14.6	120	210

Mechanical Properties of Potential Mirror Substrate Materials

*Maximal achievable value. The 'working' value is typically much less and depends on the surface/subsurface condition.

Companies are confident they can deliver the Be, BeAl and AlSi substrates fabricated with necessary tolerances for fine-figuring and polishing

Additional Benefits of metal substrate:

- Fewer joints – smaller epoxy-induced errors
- Thermal design could be simplified with the support structure fabricated from the same material

Ideally, the mirror shell has low density, low coefficient of expansion (CTE), high modulus of elasticity and high yield strength. It should also be a material that is not too difficult to figure and polish.

Substrates can be plated with the nickel phosphorous alloy:

- Be + NiP (CATS-ISS telescope)
- BeAl + NiP
- AlSi + NiP



Direct Fabrication - Metal

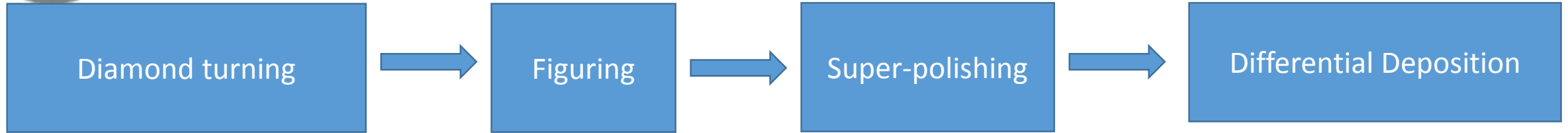

Challenge of shell thickness - fixtures

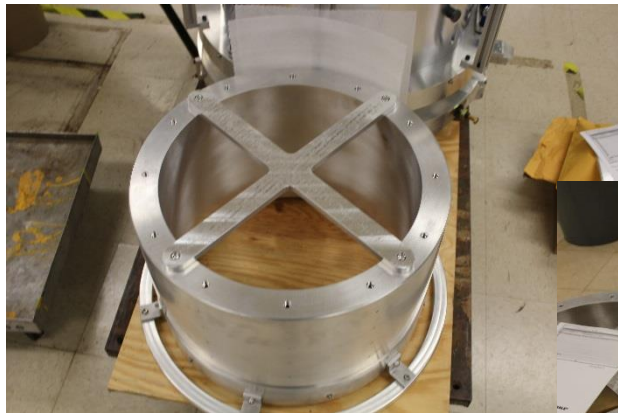

OD DT fixture



ID DT fixture



Polishing fixture



Whiffle tree station with an aluminum shell supported at 12 points.



A metrology fixture to support the mirror shell during the skip test.

Direct Fabrication

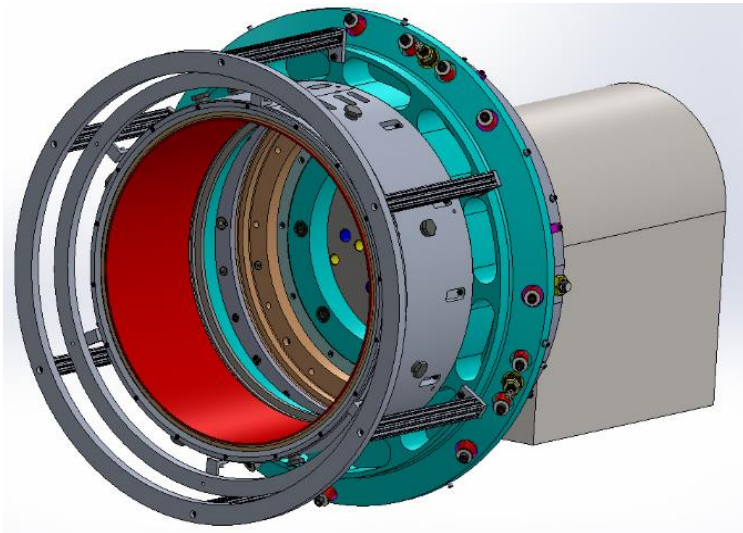

Backing support system installed on the precision lathe for diamond turning. The precision stage (blue) permit alignment of the mirror shell (red) with the lathe.



Thin-shell backing support system. A thin layer of backing material (not shown) acts as interface between the mirror shell (red) and the stiff outer support clam-shell (gray). The support rings and the gaskets shown contain the backing material.

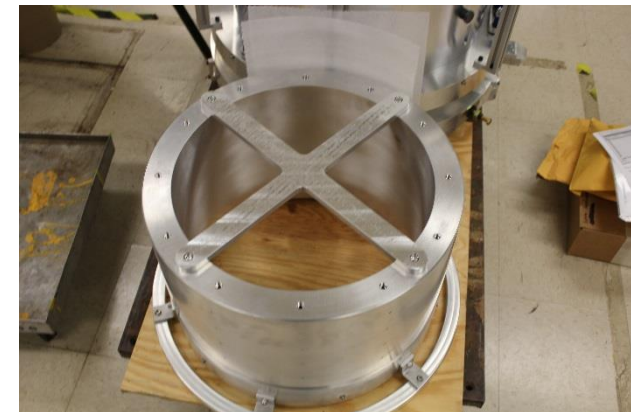
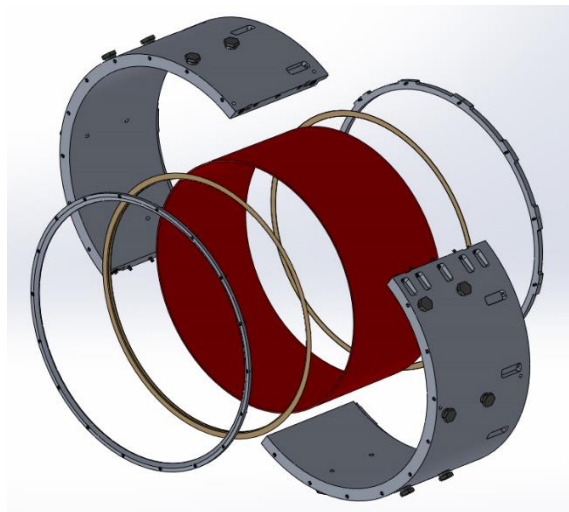



Zeeko machine

- The machine utilizes a “bonnet” technique in which an inflated rubber hemispherical diaphragm supports the polishing medium.
- there are different “bonnet” sizes (20 mm, 40 mm and 80 mm radii of curvature)
- This computer-controlled deterministic polishing process leads to a high convergence rate.

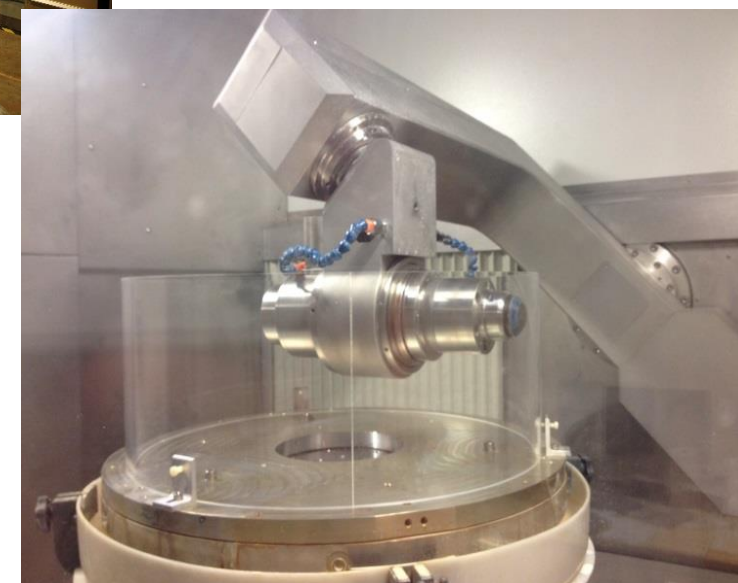

Wear function characterization

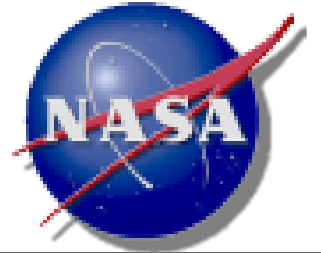

Example of Output from **Model Run**

Parametric wear pattern simulation enables a more efficient method of exploring the polishing parameter space.

Based on Preston's law:

Wear rate is proportional to

Bonnet pressure distribution

Velocity of bonnet surface

Velocity depends on

Spindle rotation

Head attack angles

Pressure depends on

Internal pressure of bonnet

Bonnet structural and mechanical properties

Static (current)

Dynamic (future)

Model is validated using measured data.

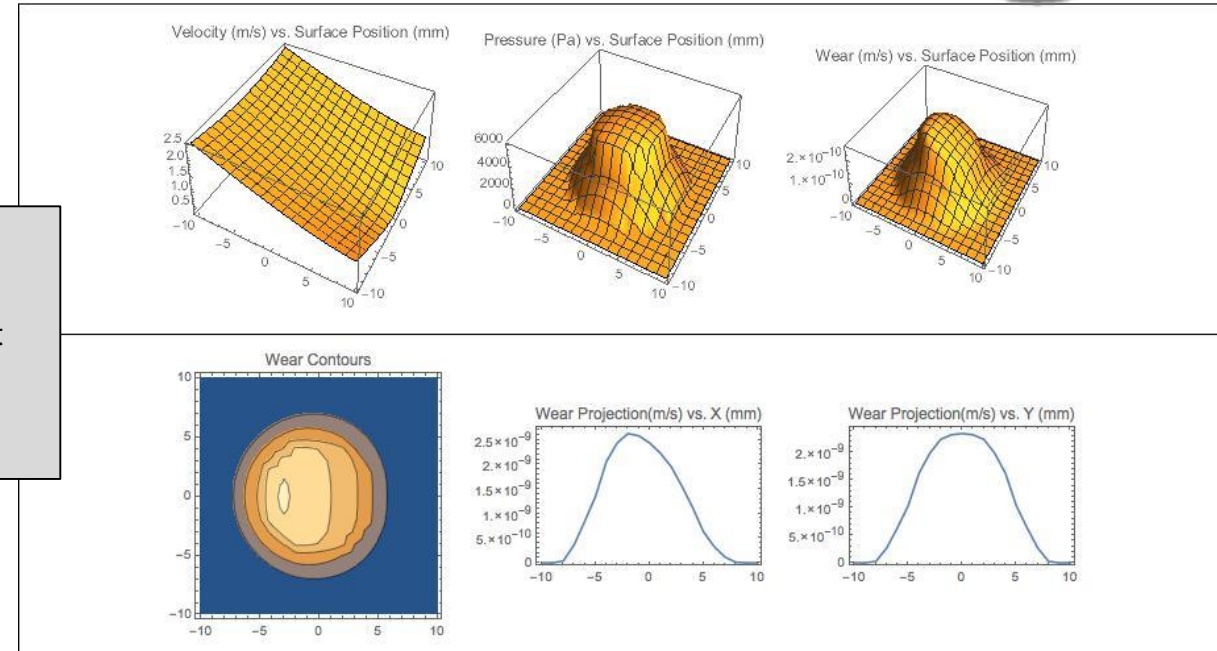
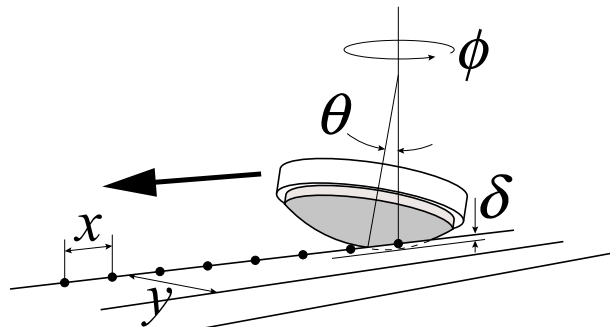
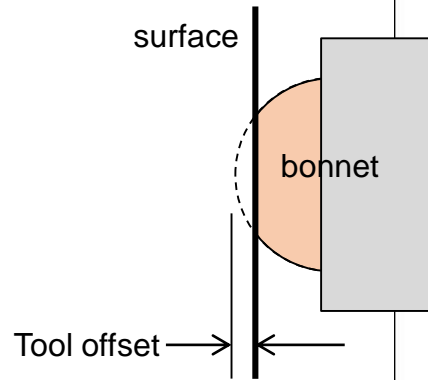

bonnet		
	value	unit
pressure	0.05	bar
thickness	0.5	mm
radius	41.	mm
density	1.3	g/cm ³
elasticModulus	20.	MPa
eModChangeFreq	0.01	MPa/Hz
poissonRatio	0.45	
damping	0.05	
dampChangeFreq	0.01	1/Hz
maxDamping	0.35	

bonnetCover		
	value	unit
thickness	0.5	mm
friction	0.04	
fracContact	0.5	

slurry		
	value	unit
viscosity	0.05	Pa s
fracSolids	0.1	
gritSize	0.03	micron
prestonCoef	2.9	10 ⁻¹⁴ /Pa
smoothScale	1.	mm

machineAxes		
	value	unit
springK	100000.	N/m
rotationRateSpindle	1000.	RPM
toolOffset	0.3	mm
precessAngle	17.	deg
phiAngle	0.	deg

surface		
	value	unit
radiusofCurvature	20.	cm
wearGridHalfWidth	10.	mm
wearGridStep	1.	mm



Wear function characterization

- Measured wear function

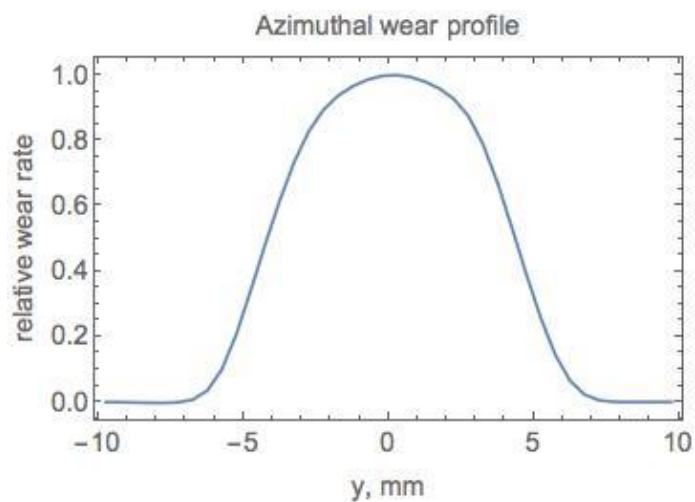
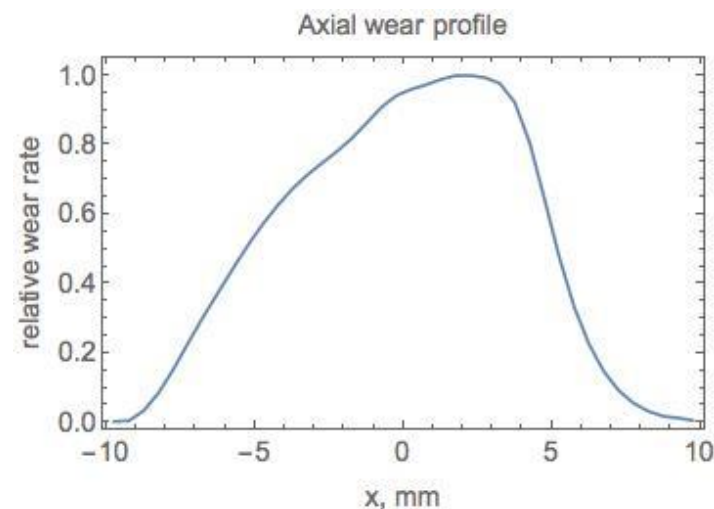
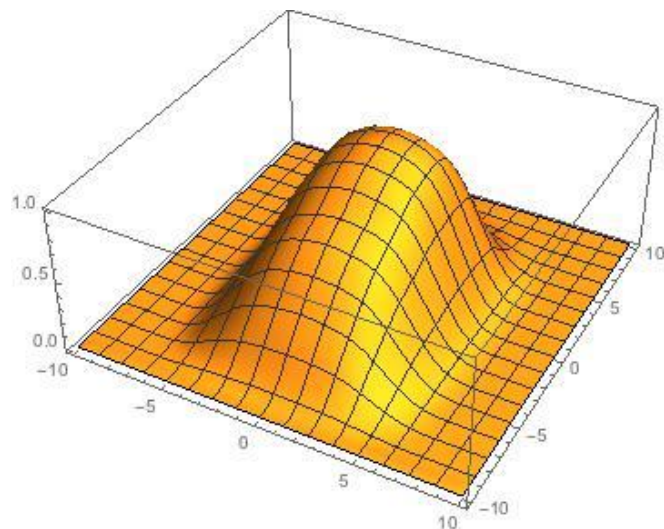

- Axial profile is asymmetric
 - Due to radial dependence of bonnet velocity relative to surface
 - Operate at 15° “precess” angle
- Axial and azimuthal directions are selected based on clearance considerations for shell polishing

Wear function characterization



- Explored polishing parameter space to balance:
 - Wear rate
 - Accuracy
- Parameter optimization
 - Bonnet pressure
 - Spindle speed
 - Tool Offset

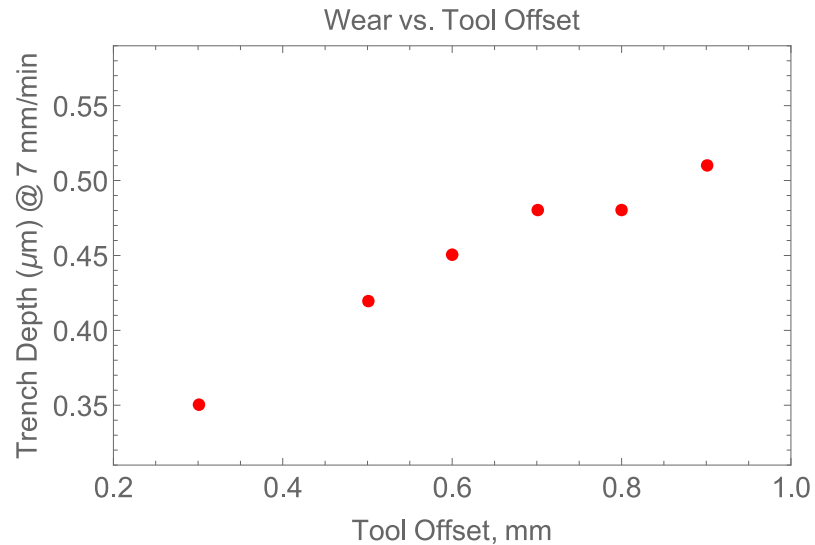

- **Example: Tool Offset**

Trench depth vs. tool offset flattens in 0.7-0.8 mm range

Results in minimal sensitivity to alignment in a $\pm 50 \mu\text{m}$ range around 0.75 mm

Selected 0.75 mm as operational tool offset



Wear function characterization

- Several options for determining the feed rate map from error map have been explored
 - Initially using a Richardson-Lucy deconvolution algorithm + small nonlinear correction
 - Tends to generate smoother edge transitions

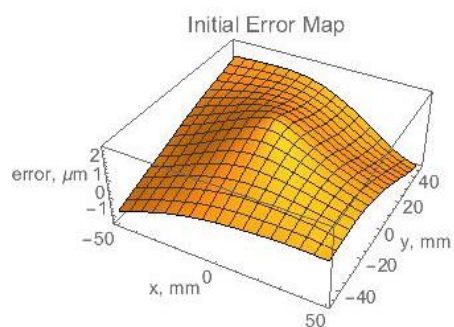

- Initial error map derived from metrology data.
- RMS slope errors along x-axis are **8 arcsec**.

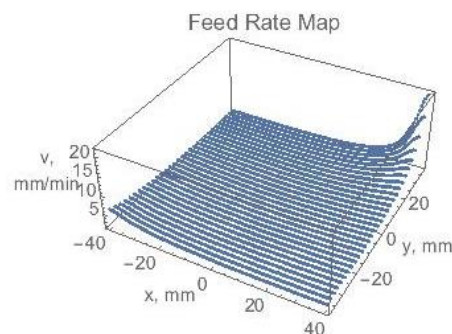

- Derived feed rate map.
- Feed rates range from 1.35-20 mm/min.

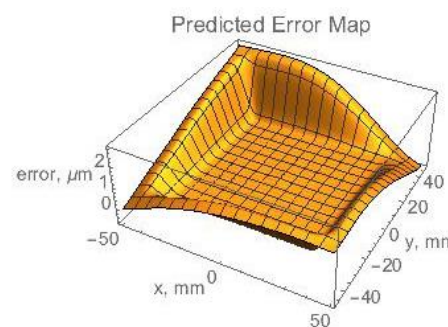

- Predicted result of polishing iteration.
- Predicted RMS slope errors are **0.6 arcsec**

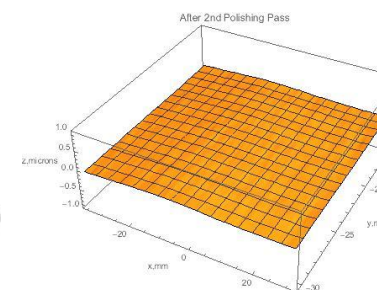

- Error map derived from metrology data.
- RMS slope errors were reduced to **0.5 arcsec**

The polishing routine software developed is validated and permit the fabrication of high resolution x-ray optics!!



Mandrel Demonstration

- Figure error correction process:
 - Initial Radii vs. axial position measured with CMM
 - Axial error map generated from Zygo data (36 meridians measured).
 - Feed rates determined from error map
 - Use axial wear function as deconvolution kernel
 - Use iterative Richardson-Lucy deconvolution algorithm
 - Select iteration that produces the smallest residual RMS slope errors
- Overall strategy
 - Initial mandrel errors >99.5% cylindrical so derive a feed rate map from 1D deconvolution of axial error map and apply to all meridians scaled for small azimuthal variations.
 - Scale the feed rates so run time fits in a work day
 - Perform a series of runs over required number of days alternating CW-CCW on alternate days to minimize daily wear rate drift
 - Iteratively measure(Zygo) and generate new feed rate map as required
 - Continue until cylindrical errors are comparable to azimuthally incoherent errors
 - Derive a feed rate map from 2D deconvolution of 2D error map
 - Perform a final series of polishing runs, possibly alternating with lap polishing to reduce out-of-band errors.

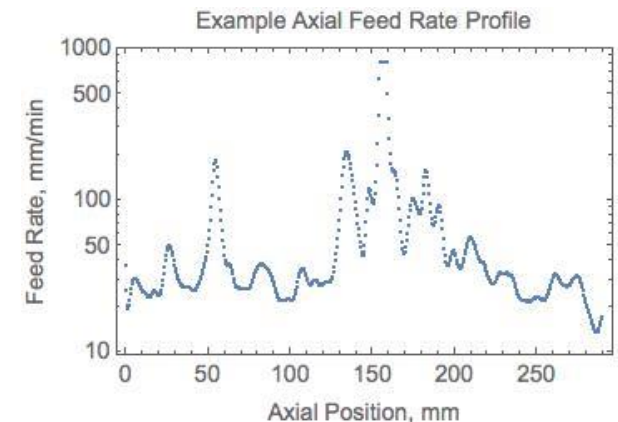
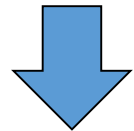
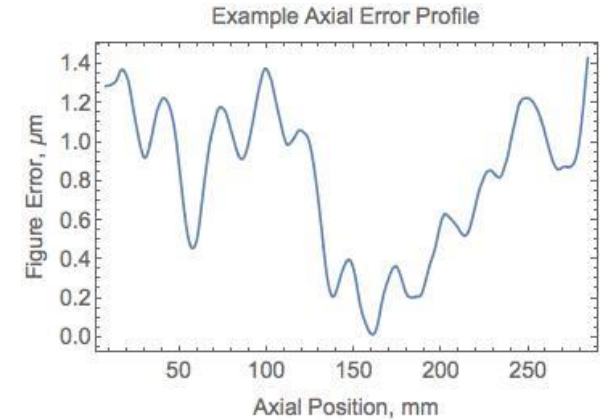



- Cylindrical Correction Complete, Polishing time: 71.5 hours

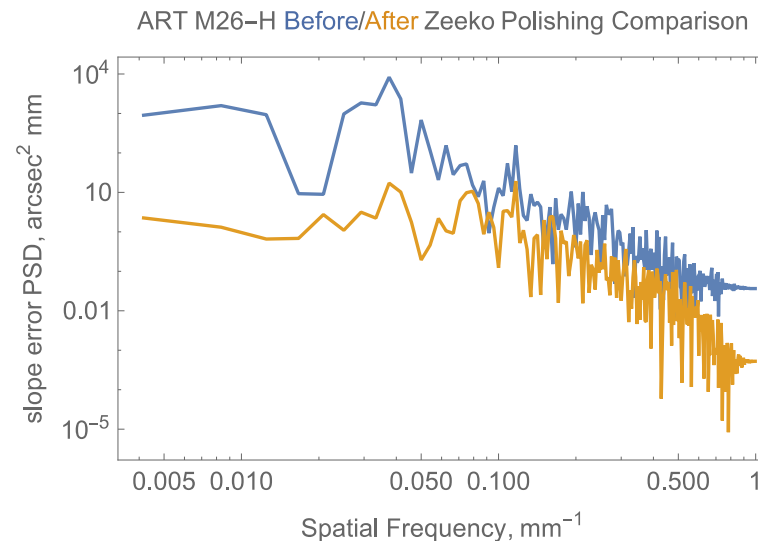
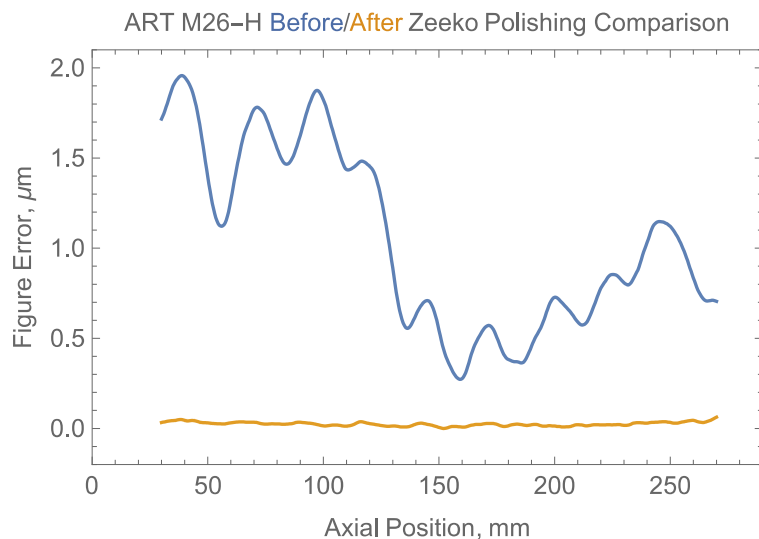

	before	after
Figure error (St. Dev.)	500 nm	10.7 nm
Slope error (> 2 cm) (RMS)	6.32 arcsec	0.30 arcsec
Low frequency (> 7 cm) slope error (RMS)	2.66 arcsec	0.09 arcsec
Mid frequency (2-7 cm) slope error (RMS)	5.73 arcsec	0.29 arcsec



Future Work

- Demonstrate the technology on a mandrel from scratch.
- Transfer the technology to NiP plated shells and segments.
- Use the differential deposition technique for further improvement of the angular resolution (to remove features with spatial extend below 7 cm)



. A NiP plated, segmented aluminum pipe with a conical inner figure fabricated for metrology, figuring and superpolishing experiments

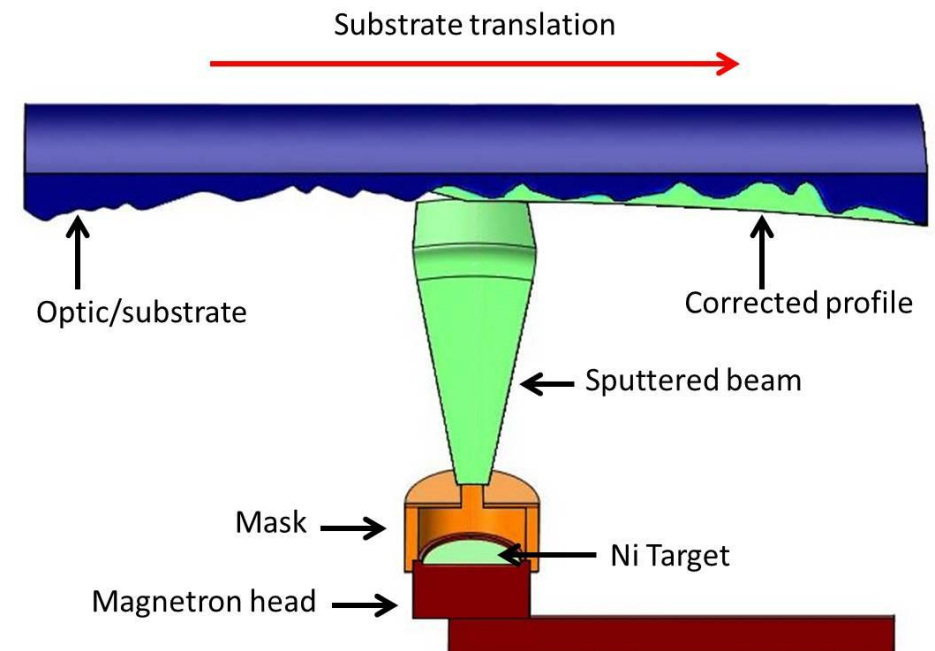

Conclusions



- MSFC is developing direct fabrication technology for full-shell x-ray optics made from metal substrates;
- Support fixtures for diamond-turning, polishing and metrology have been developed;
- Wear functions were determined using NiP plated flat samples;
- Tool path generation software has been developed;
- Slope error level is consistent with 1-2 arcsec optics
- The technique can be married with the Differential Deposition for further improvements