

Optical Relay for Future NASA Geosynchronous Orbiting Satellite for High Data Rate Links to NASA User Missions

Joseph H D. Warner¹

Comsat Architects, 20525 Center Ridge Rd. Ste 614, Rocky River, Ohio
216-767-5660 joseph@comsat-architects.com

Kul Bhasin¹

Comsat Architects, 20525 Center Ridge Rd. Ste 614, Rocky River, Ohio
216-767-5660 kul@comsat-architects.com

Jared Early¹

Comsat Architects, 20525 Center Ridge Rd. Ste 614, Rocky River, Ohio
216-767-5660 jared@comsat-architects.com

Steven Oleson²

NASA Glenn Research Center, 21000 Brookpark Rd, Cleveland, OH 44135
216-433-6165 steven.r.oleson@nasa.gov

James Stegeman²

NASA Glenn Research Center, 21000 Brookpark Rd, Cleveland, OH 44135
216-433-3389 stegeman@nasa.gov

Nang Pham²

NASA Glenn Research Center, 21000 Brookpark Rd, Cleveland, OH 44135
216-433-6165 nang.t.pham@nasa.gov

Abstract

NASA is exploring options for its Next Generation Relay (NGR) architecture while the current Tracking Data Relay Satellite System (TDRSS) completes its mission. The plan is to start implementation of the NGR beginning around 2025. The new system of proposed relay satellites will greatly increase the data rates between low Earth orbiting (LEO) satellite missions and the NASA TDRSS relay satellites. This increase in data rates will allow an unprecedented increase in data throughput from the LEO satellite missions back to the principal investigators (PI). This can be accomplished at Ka-band frequencies with high order modulation or at optical frequencies using Differential Phase Shift Keying (DPSK).

The first satellite in the next set of relay satellites will have to be backward compatible with current technology to support ongoing and planned missions. The new set of satellites will be launched over a 10-year period with design lifetimes of at least 15 years. To meet these requirements, we analyzed various architectures and designed both the communication payloads on the relay satellite and candidate payloads on the user spacecraft by utilizing optical heads already designed.

From this analysis, a demonstration optical satellite named “the Next Generation Optical Relay Pathfinder” with Ka-band capabilities was proposed to be built and launched with the purpose of evaluating an integrated high-speed optical and Ka-band communication system. Given a cost limit for the demonstration satellite, various satellite configurations were developed by varying the number of optical communication payloads. The communication payload on the relay satellite consisted of three major sub-systems: 1) Optical communication payload, 2) Ka-band communication payload, 3) Digital processing and routing of signals. The size, mass (weight), and power (SWaP) of the communication payload and other sub-systems of the satellite were obtained. The NASA Glenn Research Center COMPASS team designed the Pathfinder satellite and performed a cost analysis for its build and launch.

In this paper, we first describe the needs, drivers, and the associated challenges for the Next Generation Optical Relay Pathfinder to be capable of connecting multiple LEO and GEO satellites at high data rates. Second, we detail the concept of operations (ConOps) and the system architecture, including the satellite configurations considered, their attributes and limitations, and the size of the satellite needed for each configuration. Third, we provide a summary of the Next Generation Optical Relay Pathfinder satellite design trades and its key elements. Finally, we present the path needed for implementation and operations.

1.0 Introduction

The satellites in NASA's Tracking and Data Relay Satellite System (TDRSS) are aging. Even with the third generation of satellites, it is predicted that gaps in TDRSS's performance will begin to occur by 2025¹. The NASA Space Communication and Navigation (SCaN) Program Office is in the midst of determining how to replace the failing satellites to make the system viable until 2040^{1,2,3,4,5,6}. The goal of the NASA SCaN Program in replacing the current TDRSS is not just to maintain current capabilities but to enhance the service to meet the growing needs among NASA users for higher data rates and less user burden. In trying to meet those goals, NASA has been researching high-speed optical communications for both near-Earth applications, which TDRSS currently serves, and planetary missions. NASA has demonstrated optical communication from the Moon with the LADEE^{6,7,8} program. NASA has also sponsored work with Massachusetts Institute of Technology (MIT) for optical communication that was to go onto the Laser Communication Relay Demonstration (LCRD).⁹

The NASA Scan Program has also conducted numerous studies on how the next generation of satellites after 2025 can use optical communications. To make that a reality, a demonstration communication satellite with optical communication and Ka-band communication has been analyzed. We have designed a variety of configurations for the Next Generation Optical Relay Pathfinder using different numbers of optical terminals that were developed for the LCRD program and potentially by commercial entities. We applied a cost constraint to these configurations to down select the configurations that would fall within a NASA budget. From these configurations, the one with the most capability within the constraints had four optical terminals, one Ku-band terminal, and one S-band terminal. The S-band terminal was for the Next Generation Optical Relay Pathfinder's own TT&C and emergency needs and will not be addressed in this paper. Only the optical and Ku-band relay functions will be discussed.

Written by section in this paper, we give the performance of the satellite versus trades on the optical terminals and how those trades affected the concept of operations (ConOps) of the satellite and what properties of the new system that could be demonstrated. The ConOps of the Next Generation Optical Relay Pathfinder used to provide connections between user satellites and the ground gateway is discussed for different Next Generation Optical Relay Pathfinder configurations.

2.0 Drivers for the Next Generation Optical Relay Pathfinder

Multiple drivers have emerged initiating the Next Generation Optical Relay Pathfinder. Since its inception, the SCaN Program Office has been engaged in the development of communication architecture for creating an integrated communication network to meet the needs of NASA and other customers' space missions.

One of the drivers for the vision of the Next Generation SCaN architecture is described in Ref [2,10] and in Figure 1.

- Connect the principle investigator more closely to the instrument, the mission controller to the spacecraft, and the astronaut to the public.
- Improve the mission's experience and reduce mission burden.
- Reduce network burden.
- Enable growth of commercial services for missions currently dominated by government capabilities.
- Establish an open architecture with interoperable services.

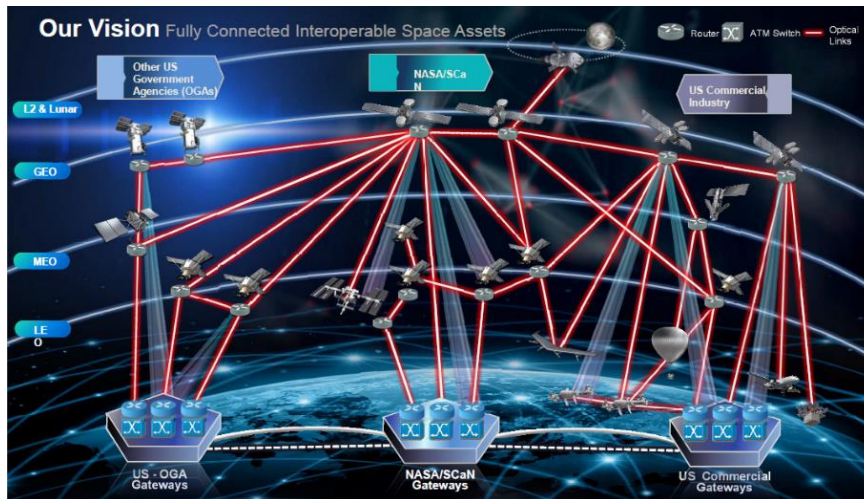

Figure 1 Next Generation SCaN Architecture

For this long term vision, the intent is to create an interoperable architecture among NASA, US agencies, and commercial entities. Figure 1 shows the need for cross-links, increased number of space links within the GEO domain, and links to the Lunar domain in this architecture.

The aging of TDRSS and upcoming new missions during the next decade will require changes in the NASA relay communication satellite network. NASA plans to enhance TDRSS to meet the growing needs among NASA missions for higher data rates, less user burden, and ease of connectivity. As a next step, NASA SCaN has conducted several studies to identify the best space communication architecture solutions for the coming decades¹⁰.

Based on these studies, an architecture is emerging. A schematic of the NASA Future Space Communication and Navigation Architecture vision is shown in Figure 2. One of the most notable changes is the addition of optical communications to achieve higher data rates for near Earth and deep space communication.

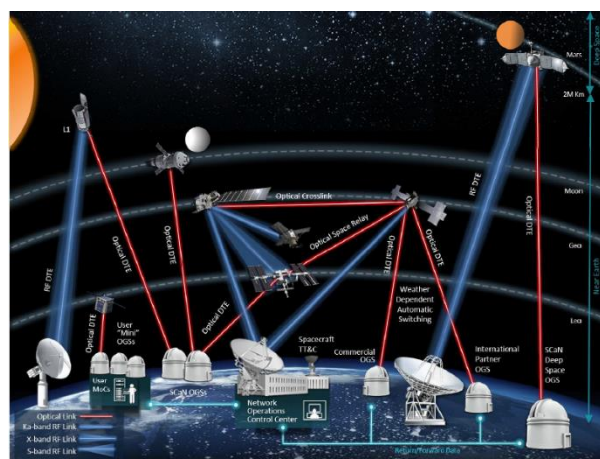

Figure 2 NASA Future Space Communication and Navigation Architecture³

Key paradigm shifts are expected to take place for the Next Generation Architecture, which will begin with the Next Generation Optical Relay Pathfinder. First, the architecture will go from all radio frequency (RF) to using both RF and optical communications. The rest are below:

1. Optical communications technology promises high data rates with low SWaP and cost for users. The optical terminal requires extremely precise pointing but has built-in vibration isolation that avoids imposing extremely high stability on the spacecraft bus. NASA has been engaged in

developing communication technology for the last several decades and is about to launch the Laser Communications Relay Demonstration (LCRD) in 2019⁶ as a precursor to operational implementation.

2. Unscheduled access will enable further system automation and operations cost reduction while eliminating scheduling for most missions.
3. Link layer services don't guarantee data delivery forcing Mission Operating Centers (MOCs) to develop software to process data for errors, resend data, and issue commands to delete data from memory. As part of reducing mission burden, the Next Generation approach includes space internetworking — the Solar System Internet (SSI) — that guarantees delivery and reduces burden on ground and flight segments, enables a Service-Oriented Architecture (SOA) providing access to additional applications, and offers the ability to move data directly from MOCs to PIs or directly from spacecraft to PIs.

The Next Generation Optical Relay Pathfinder is the first step in accomplishing the “Next Generation Architecture Vision”.

2.1 Near-Term Earth Network Architecture and Next Generation Optical Relay Pathfinder Requirements

From the needs and drivers described in the previous sections, we developed various requirements for the Next Generation Optical Relay Pathfinder based on NASA Headquarters requirements, various assumptions that were made, and information that was already known. The Next Generation Optical Relay Pathfinder requirements are based on the Earth Network Architecture planned for 2025, discussed in the next section.

2.1.1 Earth Network Architecture

An initial Earth Network Architecture concept for the second generation of optical relay satellites, planned for implementation from 2025 onward, is shown in Figure 3. The initial operational capability of the NASA Space Ground Network and Earth Relay will occur around 2025 driven by the need to replace the capacity of TDRSS as its satellites are retired. The envisioned architecture will support 100 Gbps downlinks, 10 Gbps user links, and 100 Gbps crosslinks for optical communication and will have a 1.2 Gbps Ka-band downlink with 99.99% availability.

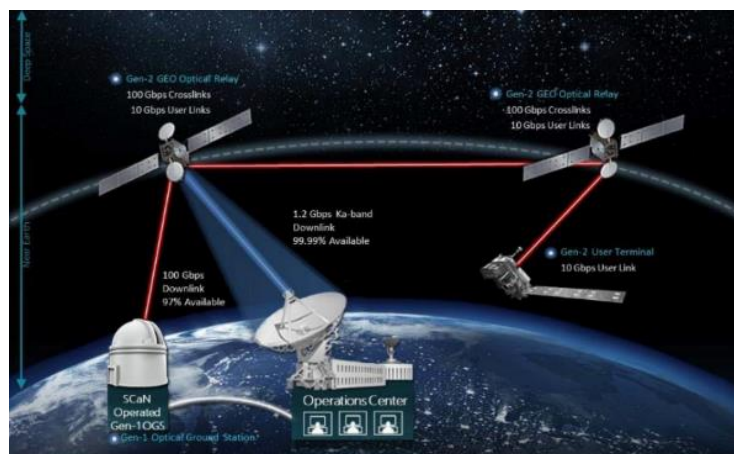

Figure 3 Initial Earth Network Architecture Concept for 2025

2.1.2 Next Generation Optical Relay Pathfinder Requirements

The minimum requirements used to design the Next Generation Optical Relay Pathfinder were that the satellite would be in Geosynchronous Earth Orbit (GEO) with a minimum lifetime of five years and a

desired lifetime of 10 years. The fault tolerance of the optical systems was zero-fault, while the fault tolerance of the RF systems was either zero-fault or single-fault if the systems were dual-polarized or single-polarized, respectively. The spacecraft avionics was single-fault tolerant.

The proposed launch date is 2023 if the small optical terminals are used exclusively, or 2025 if larger optical terminals (20 cm aperture) are used. This will give cut-off data for the Technology Readiness Level (TRL) on lighter components of 2021 except for the largest terminal.

The data rates that are to be supported by the Next Generation Optical Relay Pathfinder are extremely high. The optical space-to-ground link (SGL) and the optical crosslink between optical relay satellites is 100 Gbps while the RF SGL must support at least 622 Mbps. The links for user missions and sub-orbitals are 10 Gbps. Links from the moon are to be 80 Gbps.

Other requirements as defined by NASA include minimizing jitter on the spacecraft; determining if ion engines for navigation is appropriate; using heterodyne optical modulation with at least DPSK modulation; routing and signaling between the various nodes of the SGL, lunar, other relay satellites, orbital users, and sub-orbital users; and having a store and forward system.

2.1.3 Next Generation Optical Relay Pathfinder

The Next Generation Optical Relay Pathfinder design is the first attempt at investigating the deployment of a satellite with multiple optical telescopes. We initially had over 20 variations of payload options that included various numbers of optical telescopes. We designed communication payloads with anywhere from two to eight telescopes and included two different sizes for the aperture diameter—10.7 cm and 20 cm. The designs also required us to look at different satellite buses to accommodate the amount of surface area the telescopes took. This satellite bus design also considered the amount of space each telescope would need around it to not be in the path of another telescope. We were quickly able to eliminate many of the options from the initial designs and ultimately ended up doing a deeper analysis and going to the COMPASS Labs with four designs, which are discussed later in this paper.

2.1.4 Optical Ground Stations

There are two optical ground stations that were considered for the analysis when designing the Next Generation Optical Relay Pathfinder⁶. The first one is in Maui, Hawaii with a 60 cm receive aperture and a 15 cm transmit aperture (see Figure 4 below). It has 10 Watts of transmitter power and 69.6% mean availability. It is currently being outfitted to support the Laser Communication Relay Demonstration (LCRD). The second optical ground station is in White Sands, New Mexico, with a 1 meter receive aperture and 58.7% mean availability.

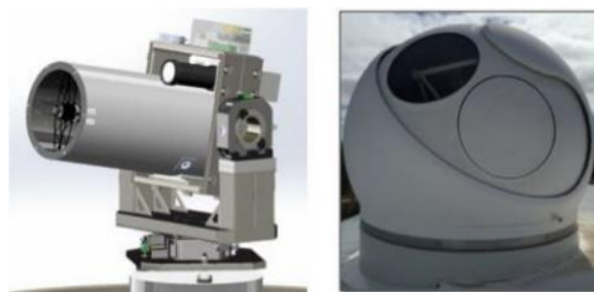

Figure 4 Optical ground stations in Maui, Hawaii and White Sands, New Mexico, respectively⁶

2.1.5 Optical Terminals

For the Next Generation Optical Relay Pathfinder analysis, we considered two different sizes to incorporate into the design and had various combinations of each to meet the design needs and requirements⁶. Figure 5 displays two optical terminal sizes. The first optical terminal considered is a 10.7 cm optical ILLUMNA-T terminal. It is mounted on a gimballed telescope with a 12° half-angle field of regard. It includes a modem, controller, and amplifier and has local inertial sensor stabilization to minimize jitter. The second terminal is a 20 cm optical 100G ILLUMNA GEO terminal, which includes a combined modem/controller and amplifier. For this analysis, it was assumed to be flight ready for the Next Generation Optical Relay Pathfinder. The yellow volume shows the volume swept by each terminal⁶.

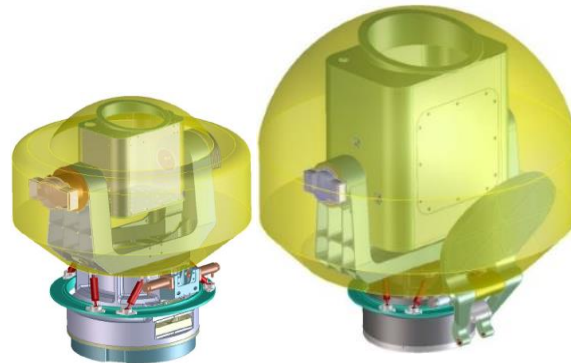

Figure 5 10.7 cm ILLUMNA-T and the 20 cm ILLUMNA GEO Terminals⁶

Along with the optical terminals, we used various electronics that are also being incorporated into the LCRD, such as the integrated modem, controller electronics, and the space switching unit shown in Figure 6. It was assumed that Pathfinder will accommodate commercially available optical terminals as well.

The integrated modem supports DPSK and PPM modulation and supports transmit and receive frame processing (no onboard coding and interleaving). It consists of a 0.5 W transmitter and an optically pre-amplified receiver. Nominally, it operates at 130 W and weighs 29.2 kg. The controller electronics have OM control/monitoring, interface to host spacecraft. It weighs 6.6 kg and has 99 W peak power while operating at 30 W nominally. The space switching unit flexibly interconnects between modems to support independent communication links (high-speed frame switching and routing) and has a command and telemetry processor. For further technical details, see Ref [6].

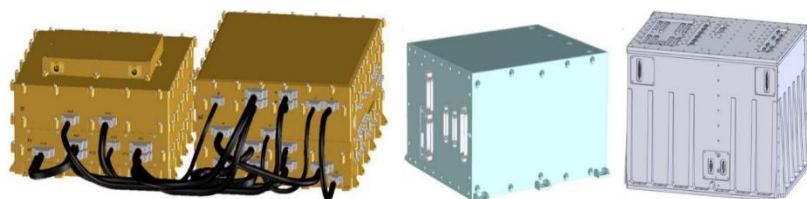

Figure 6 Integrated Modem, Controller Electronics, and Space Switching Unit⁶

2.2 Concept of Operations

The ConOps for the Next Generation Optical Relay Pathfinder is that it will be tested for future use of optical communications for NASA, other government agencies, and commercial communication companies. For that reason, the design of the Next Generation Optical Relay Pathfinder included space on the satellite for commercial companies and other government agencies to place and to integrate their optical terminals with those supplied by NASA.

The relay satellite will be able to communicate with satellites in orbit between 300 and 800 km in altitude and provide a cross-link to another GEO satellite. In addition, the Next Generation Optical Relay Pathfinder will be able to demonstrate optical communication relay support to government planes and fixed ground entities. The NASA optical terminals will also be positioned to support human missions beyond GEO.

The Next Generation Optical Relay Pathfinder will communicate to either the 60 cm optical terminal in Hawaii or the 1 meter terminal at White Sands. The Next Generation Optical Relay Pathfinder will demonstrate 10 Gbps from LEO, planes, and ground stations while the cross-link will be able to demonstrate 100 Gbps.

The optical gateway to Earth could have a capability of 100 Gbps. For the Ka-band, we will use an antenna with a 1.0-meter aperture. The Ka-band antenna will link to the 18.3-meter antenna at White Sands. The constraint on the cost of the Next Generation Optical Relay Pathfinder gave a solution of using a helix antenna with a gain of 18 dB and the use of a 40 W band amplifier. This link gave a data rate of 50 Mbps. Still, the data rate at Ka-band is sufficiently high to demonstrate switching data between the optical and RF path.

Figure 7 shows one of the possible configurations of the Next Generation Optical Relay Pathfinder used to establish communication method from the mean back to the principal investigation or customer.

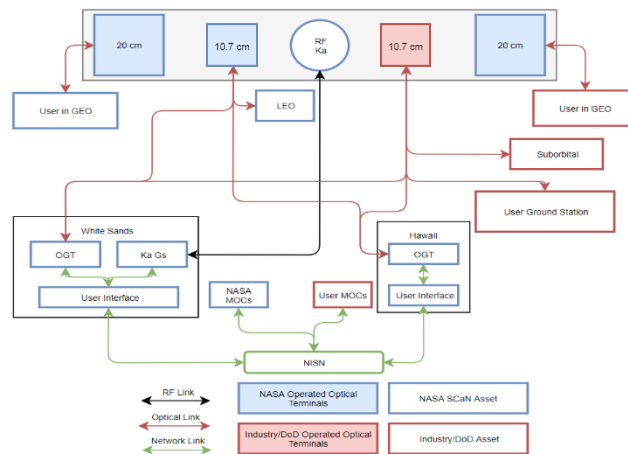

Figure 7 Possible Configuration of the Next Generation Optical Relay Pathfinder Concept of Operations

As can be seen in Figure 8, the Next Generation Optical Relay Pathfinder can use the two large 20 cm aperture terminals for ultra-high-speed links between ground gateways and the optical relay satellites. The two 10.7 cm terminals will support users' optical needs by up to 10 Gbps. In addition, the 10.7 cm terminals can provide the link to a gateway if necessary. Since the Next Generation Optical Relay Pathfinder is a demonstration satellite there is a minimum amount of redundancy built into the optical paths. The Ka-band systems will be used for gateway support and data download up to data rates of 50 Mbps.

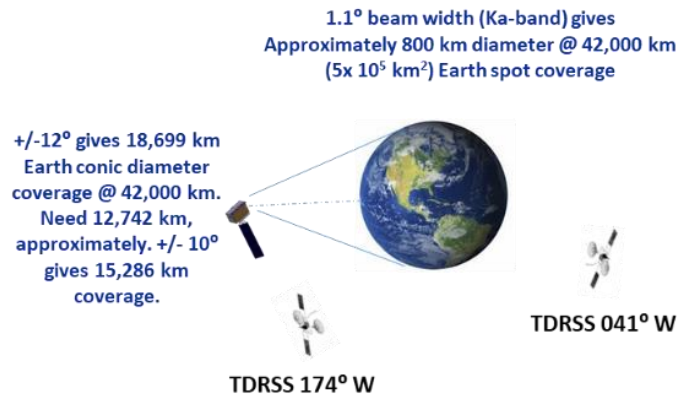

Figure 8 Operations View of the Next Generation Optical Relay Pathfinder After it is Deployed

The Next Generation Optical Relay Pathfinder is anticipated to be located at 174°W and can support all current NASA missions in LEO if they have optical communication capabilities. In addition, it will be able to support missions in the cis-lunar region.

3.0 Optical and RF Link Budget Analysis

Any user spacecraft must have a communication payload to be supported by Pathfinder. The Next Generation Optical Relay Pathfinder satellite is going to include two communication payloads—one optical and one RF. The RF payload is to support a DTE link as an alternative to an optical DTE link. Based on the needs, drivers, and requirements, we were able to identify parts of the payload architecture that we would be able to trade in the link analyses. Performing the link analyses allows us to get preliminary estimates for the size, weight, and power of the communication payloads. Other subsystems can then be appropriately sized based on the communication link results, such as the amount of memory required on board for data storage.

3.1 Optical Link Analysis

There were various trades performed as part of the optical link analysis using a link tool developed at NASA Glenn Research Center. Table 1 below summarizes the parameters that were traded as well as the range of values that were considered. The optical terminal's apertures on Pathfinder and on Earth had values of 10.7 or 20 cm, and 40 or 100 cm, respectively, because of the ILLUMNA terminals and the available optical ground stations discussed previously. We varied the laser transmit power from a half watt up to five watts to cover an order of magnitude of possible transmitting powers. We also analyzed all the types of links that the Pathfinder is anticipated to have—downlink, crosslinks, and user links. We used two platform jitters of 0.65 microradians and 0.80 microradians, which is discussed in further detail in the next section to analyze the effect of the platforms on the link performance.

Table 1 Summary of Parameters Traded within Optical Link Analysis

Variable/Parameter Traded	Traded Values
Optical Terminal Diameter on Pathfinder (and another GEO satellite)	10.7 cm, 20 cm
Optical Terminal Diameter on Earth	40 cm, 100 cm
Average Laser Transmit Power	0.5 W, 1.0 W, 2.5 W, 5 W
Type of Link	Pathfinder – Earth, Pathfinder – LEO User, Pathfinder Crosslink
Platform Jitter on Pathfinder	0.65 microradians, 0.80 microradians

The optical beam modulation used was DPSK, because of the high data rates desired. Single photon counting technique was not considered because current digital processing and timing control are not fast enough.

3.1.1 Effect of jitter on data rate versus aperture size

Through our optical analysis, we learned that the platform jitter had a significant impact on the overall data rate that could be achieved by the terminals. In general, a larger aperture diameter leads to larger data rates for small jitter, where all other parameters are held constant. For jitters under 1.25 microradians the 20 cm aperture gave a data rate larger than the 10.7 cm aperture as seen in Figure 9.

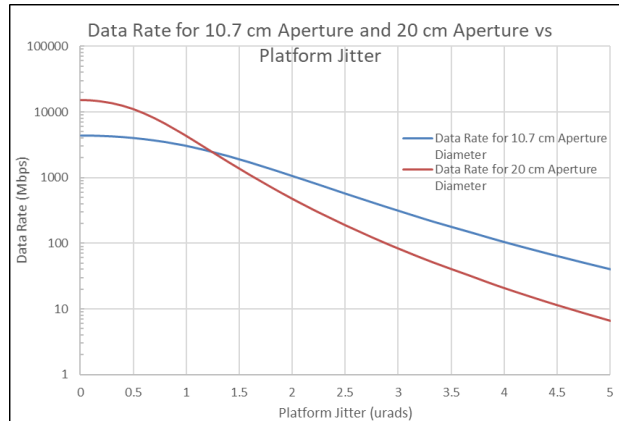

Figure 9 Data Rate vs Platform Jitter for 10.7 cm and 20 cm optical terminals

The blue line represents the data rate of the 10.7 cm aperture telescope vs the platform jitter. The red line represents the same information for the 20 cm aperture telescope. As can be seen in the graph, the 20 cm telescope has diminishing or negative returns as the platform jitter increases when compared to the 10.7 cm telescope. The phenomena were generalized by graphing the normalized data rate vs the ratio of platform jitter angle to beam width divergence angle, as shown in Figure 10.

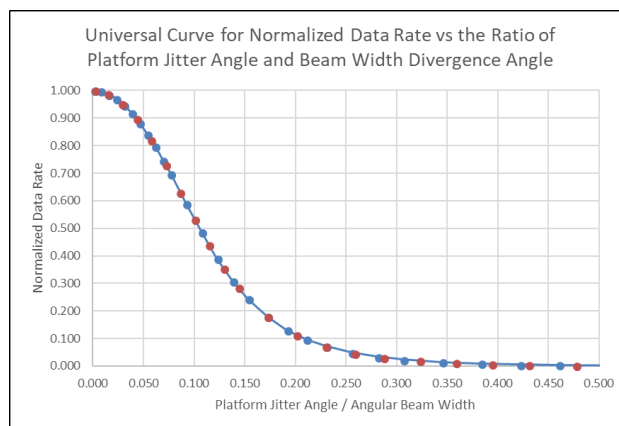

Figure 10 Universal Curve for Normalized Data Rate vs Ratio of Platform Jitter Angle and Beam Width Divergence Angle

The blue dots represent the normalized data rate vs the given x-axis for a 10.7 cm telescope, while the red dots represent the same information for a 20 cm telescope. This curve tells us what percent of the maximum data rate is achievable for a given ratio between the platform jitter angle and the angular beam width. For the UAV/LEO to the Next Generation Optical Relay Pathfinder analysis, we assumed that the maximum allowed platform jitter angle is 10% of the telescope's beam width. From the graph, we can then see that at 10%, the maximum data rate achievable is approximately 50% of the absolute maximum data rate when there is no platform jitter.

3.1.2 Optical Link Analysis Results

Tables 2, 3, and 4 give the data of optical links for the different size terminals on the Next Generation Optical Relay Pathfinder. Table 2 shows the data rates from the 10 cm and 20 cm optical terminal to the

40 cm and 100 cm telescope on the ground. Table 3 gives data rate at the maximum distance between LEO and GEO spacecraft for different jitters on the transmitting optical terminal.

The preliminary data rates (in Gbps) of an optical link between the Next Generation Relay and ground stations are calculated assuming a link margin within 2 dB with coding, a distance of 35,790 km, and ignoring electronic limitations.

Table 2 Maximum Data Rate Achievable for DTE and Power Requirements for Given Assumptions

Optical Telescope Output Power			
Optical Aperture Terminal Sizes (Satellite to Earth)	Data Rate (Gbps) at ½ Watt	Data Rate (Gbps) at 2.5 Watts	Data Rate (Gbps) at 5 Watts
10.7 cm to 40 cm	8.62	43.11	86.13
10.7 cm to 100 cm	53.88	269.2	538.3
20 cm to 40 cm	24.42	122.1	243.9
20 cm to 100 cm	152.6	762.2	1,524

The preliminary data rates (in Gbps) of an optical link between LEO and GEO satellites are calculated assuming a link margin within 2 dB with coding and a distance of 42880 km. LEO satellites are also assumed to have the same size and power parameters as the Next Generation Optical Relay Pathfinder in GEO.

Table 3 Maximum Data Rate Achievable Between LEO to GEO Satellites and Power Requirements for Given Assumptions

Optical Telescopes Average Output Power			
Optical Terminal Aperture Sizes (Satellite to Satellite)	Data Rate (Gbps) at ½ W	Data Rate (Gbps) at 2.5 W	Data Rate (Gbps) at 5 W
10.7 cm to 10.7 cm with Jitter of 0.8 μrads	1.77	8.86	17.68
10.7 cm to 20 cm with Jitter of 0.8 μrads	7.09	35.39	70.76
20 cm to 10.7 cm with Jitter of 0.65 μrads	5.02	25.06	50.09
20 cm to 20 cm with Jitter of 0.65 μrads	20.05	100.2	200.2

The preliminary data rates (in Gbps) of an optical link between GEO and GEO satellites are calculated assuming a link margin within 2 dB with coding and a distance of 73,000 km.

Table 4 Maximum Data Rate Achievable for Cross-Links Between GEO Satellite and Power Requirements for Given Assumptions

Optical Telescopes Sizes and Average Output Power			
Optical Terminal Aperture Sizes on Each Satellite	Data Rate (Gbps) at ½ W	Data Rate (Gbps) at 1 W	Data Rate (Gbps) at 5 W
10.7 cm to 10.7 cm	0.49	0.98	4.88
10.7 cm to 20 cm	1.95	3.90	19.54
20 cm to 10 cm	2.76	2.76	13.82
20 cm to 20 cm	5.53	11.05	55.24

3.2 RF Link Analysis

We performed a preliminary static RF link analysis to get an estimate of what data rates were achievable and the amount of power it would take. For this analysis, we looked at various bandwidths, modulations, and antenna sizes on the Next Generation Optical Relay Pathfinder.

3.2.1 Inputs, Assumptions, Requirements

The ground station used for the RF link analysis was the 18.3-meter antenna located at White-Sands, New Mexico, with an approximate link distance of 42,000 km. The amount of available bandwidth for this link was assumed to be either 1.0 GHz, 1.5 GHz, or 2.0 GHz while using 16-APSK or 32-QAM modulation types. Finally, the antenna sizes we traded were one meter and two meters in diameter. All links required a 3-dB margin.

3.2.2 RF Link Analysis Results

Table 5 below summarizes the results of our findings. With the smallest bandwidth and smallest antenna at 16-APSK, the link can accomplish 2.175 Gbps using 16.63 Watts of power. With the largest available bandwidth and the largest antenna diameter, and using 32-QAM, the link can achieve 6.625 Gbps at 23.62 Watts of power.

Table 5 Maximum Data Rate Achievable and Power Requirements for Given Assumptions

Bandwidth (GHz)	Modulation Type: 16-APSK		Modulation Type: 32-QAM	
	Pathfinder Antenna Size (m)			
	1m	2m	1m	2m
1.0	2.175 Gbps @ 16.63 W of Power	2.175 Gbps @ 4.16 W of Power	3.3 Gbps @ 47.44 W of Power	3.3 Gbps @ 11.78 W of Power
1.5	3.275 Gbps @ 25.06 W of Power	3.275 Gbps @ 6.27 W of Power	4.95 Gbps @ 70.65 W of Power	4.95 Gbps @ 17.67 W of Power
2.0	4.350 Gbps @ 33.27 W of Power	4.350 Gbps @ 8.32 W of Power	6.625 Gbps @ 94.43 W of Power	6.625 Gbps @ 23.62 W of Power

4.0 Configurations of Optical Communication Payload

To meet the user data rate requirements and cost limit, we considered several options for the optical communication payload configurations. These options were identified based on the sizes, cost, and availability of the commercial satellite buses. We narrowed down four different configurations of the Next Generation Optical Relay Pathfinder as shown in Figure 11. The four basic the Next Generation Optical Relay Pathfinder configurations considered had two, four, six, or eight optical terminals with apertures of either 10.7 cm or 20 cm and a 1-meter RF parabolic antenna. Option 1 shows eight terminals of 10.7 cm. Option 2 displays six terminals of 10.7 cm. Option 3 contains four optical terminals of 10.7 cm. Option 4 shows two terminals of 10.7 cm and two terminals of 20 cm. These configurations can provide 100 Gbps data rates from the Pathfinder to the ground for the optical link. Each configuration included a Ka (23/26 GHz) gateway link to the Earth gateway.

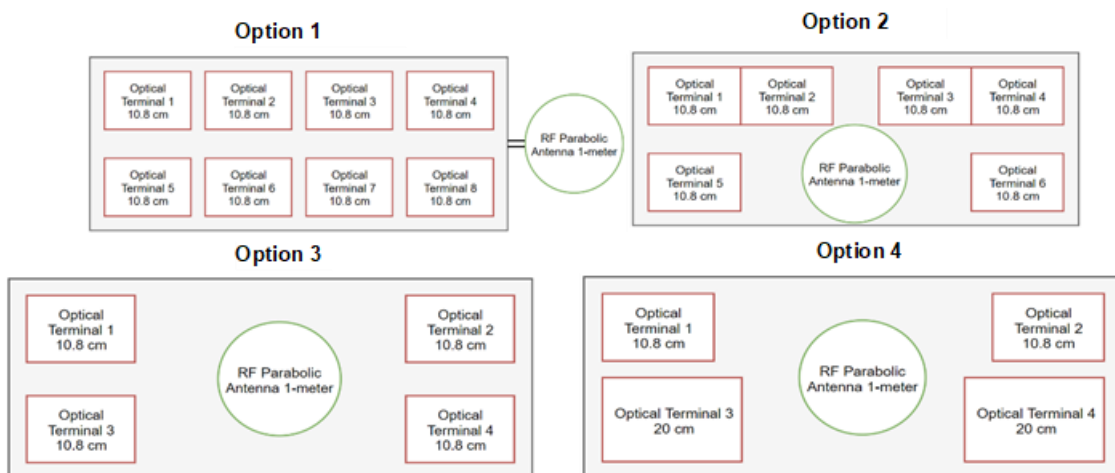

Figure 11 Schematic Four Optical Communication Payload Options

Table 6 below reiterates the four optical communication payload options shown above. The number of optical apertures and sizes are listed next to each option terminal. Also, the location and purpose of each of the four options are shown.

Table 6 Option Terminals

Option Number	Number of Optical Apertures and Size	Location and Purpose
Option 1 Eight 10.7 cm Terminals	Four 10.7 cm	Edge of Nadir Crosslink, DTG, and Users
	Four 10.7 cm	Middle of Nadir DTG and Users
Option 2 Six 10.7 cm Terminals	Four 10.7 cm	Edge of Nadir Crosslink, DTG, and Users
	Two 10.7 cm	Middle of Nadir DTG and Users
Option 3 Four 10.7 cm Terminals	Four 10.7 cm	Edge of Nadir Crosslink, DTG, and Users
Option 4 Two 10.7 cm Terminals Two 20 cm Terminals	Two 10.7 cm	Edge of Nadir Crosslink, DTG, and Users
	Two 20 cm	Edge of Nadir Crosslink, DTG, and Users

4.1 Options Analysis for Configurations

The criteria for the option analysis for the payload configurations presented above was the cost of the development, deployment and launch, as well as the ability to meet the ConOps and user requirements. The cost criteria were used at the end based on the preliminary cost, and only options three and four were found to be viable. The architecture and the ConOp required crosslinks of 100 Gbps. The highest data rates for the crosslinks were achievable by 20 cm optical terminals. As shown above, option four meets that requirement and it was chosen to proceed with detailed design to access feasibility, cost estimation, technology gap identification and risk assessment.

5.0 Next Generation Optical Relay Pathfinder Design

In designing the spacecraft, we investigated several satellite buses before generating our generic satellite bus. The platforms considered were Orbital ATK's GEOStar 2, GEOStar 3, ESPASat, and Gemini; Boeing's 702HP, 702HP-GEO, 702MP, and 720SP; Lockheed Martin's A2100; and Space Systems Loral's SSL 1300 (small, medium and large).

Table 7 Wet Mass, Payload Mass, Power, and Dimensions of Satellites from Orbital ATK, Boeing, Lockheed Martin, and SSL

	Orbital ATK				Boeing				Lockheed Martin	SSL (Space Systems/Loral)		
	GEOStar-2	GEOStar-3	ESPASat	Gemini	702HP	702HP-GEO	702MP	720SP	A2100	SSL 1300 (Small)	SSL 1300 (Medium)	SSL 1300 (Large)
Wet Mass (kg)	3325	PNA	PNA	PNA	5400	5100	5800	1500	6000	1300 – 2400 (Dry)	1700 – 3000 (Dry)	2500 – 4200 (Dry)
Payload Mass Capability (kg)	500	800	1086	1000	600 to 1620	1250 to 1480	300 to 650	200 to 680	PNA	PNA	PNA	PNA
Power (kW)	Up to 5.55 orbit average	8	1.2	5	>12	8 - 10	6 - 12	3 - 8	7.5 – 12	5 – 9	10 – 15	13 – 20+
Dimensions (m)	1.75 x 1.7 x 1.8	3.0 to 3.9 x 2.1 x 2.3	1.6 (dia) x 0.6 (height)	PNA	PNA	PNA	PNA	4.6 (high) x 2.1 (width)	PNA	2.6 – 3.1 (height)	3.6 – 4.5 (height)	5.6 – 6.1 (height)

Electric Propulsion?	No	No	No	Yes	Mix	Mix	Mix	Yes	PNA	All Electric/Hybrid	Hybrid	Hybrid
----------------------	----	----	----	-----	-----	-----	-----	-----	-----	---------------------	--------	--------

Table 7 gives the wet mass, payload mass, power, and dimensions of satellites from Orbital ATK, Boeing, Lockheed Martin, and SSL. The NASA GRC COMPASS Design Lab used a generic bus during the pre-formulation studies based on the commercially available buses. This bus size allowed for the placement of all the optical and RF terminals in Option 4 as seen in Figures 11 and 15.

To meet the cost limit, Option 4 from Figure 11 was chosen with three of the four optical terminals planned to be provided by the government and one optical terminal reserved for a commercial partner. The RF terminal, onboard processor, and routing hardware will also be provided by the government. The mass and footprint allocated for the commercial optical terminal were assumed to be the same as NASA's 20 cm terminal.

5.1 Communication Payload Design for Option Four

Figure 12 shows the top-level schematic of the Next Generation Optical Relay Pathfinder's communication payload architecture. The COMPASS team used given components that have already been developed or are currently being developed under other programs whenever possible to develop the master equipment list (MEL). Figure 12 shows the initial block diagram of the communication system for the Next Generation Optical Relay Pathfinder. It shows that the Next Generation Optical Relay Pathfinder will have 4 optical terminals and one Ka (26.5 GHz) / K (23 GHz) terminal to be able to relay the signals from the user to the ground. In addition, the Next Generation Optical Relay Pathfinder will be able to give needed navigation data to user spacecrafts. The onboard memory is used for buffering when the links to the ground and other spacecrafts are not available. The space switching unit is the heart of the Next Generation Optical Relay Pathfinder. As great as the optical module's performance is, the space switching unit is the module that enables the routing of 100 Gbps onboard the Next Generation Optical Relay Pathfinder.

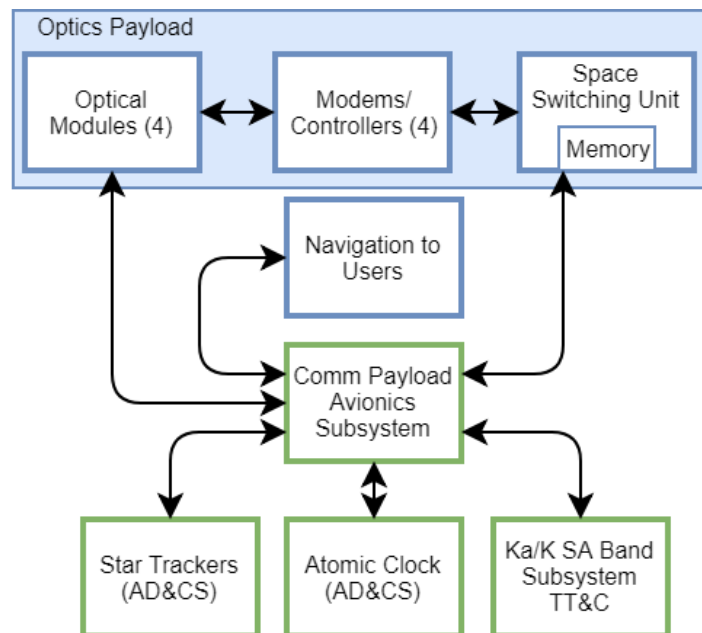

Figure 12 Internal Communication Circuit Configuration

5.2 Satellite Bus

The optical payload consists of the four optical terminals, their modems, and a high-speed space switching unit. To be able to provide navigation services and to maintain proper attitude control of the optical terminal, a communication avionics sub-system is necessary with onboard processing and attitude control of the optical and RF terminals. In addition, the avionics unit communicates to the ground through the Ka/Ku band terminal.

Table 8 gives the master equipment list for the optical part of the communication payload. The masses of the individual items come from components developed under the LCRD.

The high-speed electronics needed by the Next Generation Optical Relay Pathfinder for in-orbit bit regeneration are presently being developed by SEAKR for NASA. This unit along with the high-speed memory forms the core of the Next Generation Optical Relay Pathfinder. It takes the data from both the optical and RF terminals and regenerates the digital data.

Figures 13 and 14 give the dimensions of the satellite bus used in the satellite design.

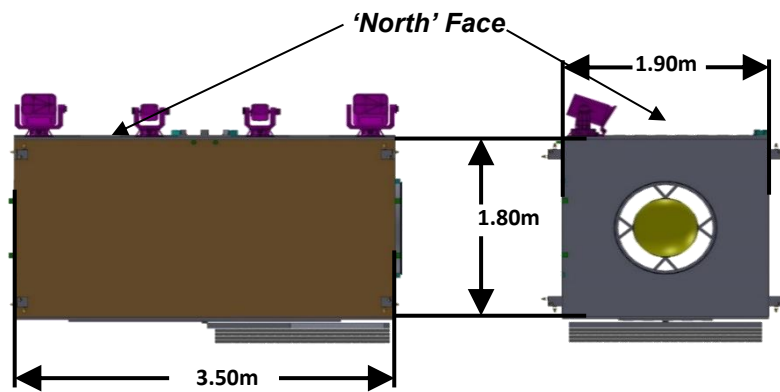

Figure 13 Optical Relay II Spacecraft Bus Dimensions Before Deployment of Solar Arrays

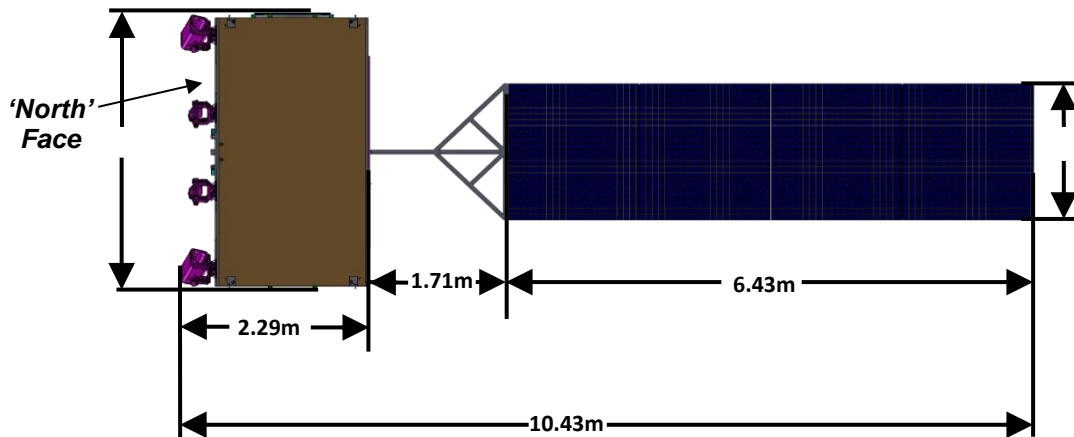

Figure 14 Optical Relay II Overall Deployed Dimensions

The optical terminals are placed on the north face of the Next Generation Optical Relay Pathfinder as seen in Figures 13 and 14. The final design of the Next Generation Optical Relay Pathfinder allows it to provide optical links to other GEO satellites, links to a future Orion, and links to LEO satellite and aircraft. The total data rate to the ground and to other GEOs is 100 Gbps, while links to LEO spacecraft and aircrafts are limited to 10 Gbps. The size of the Next Generation Optical Relay Pathfinder allows it to be launched directly to GEO on an Atlas 411 with a 501 kg margin. This margin could be used by another program to offset launch cost.

5.3 Spacecraft Design

Figure 15 shows the final design of the satellite without solar panels, RF communication, and propulsion engine. It shows the placement of major components of the satellite. The components associated with the optical payload are colored purple.

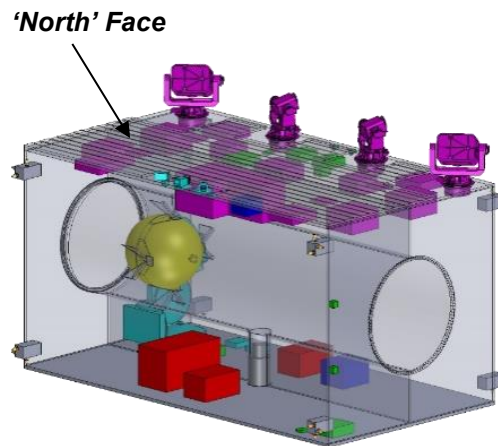

Figure 15 Optical Relay II Transparent Overall Design

As stated before, this conceptual design of a Next Generation Optical Relay Pathfinder provides data rates up to 100 Gbps for down and crosslinks. The satellite can downlink to one of two ground sites. The high data rates allow future optical relay satellites to support more users in the future.

Table 8 gives the master equipment list (MEL) for the major non-communication components of the Next Generation Optical Relay Pathfinder.

Table 8 MEL Non-Communications Part of the Next Generation Optical Relay Pathfinder

Description	Basic Mass (kg)	Growth (%)	Growth (kg)	Total Mass (kg)
Structures and Mechanisms	31.9	18.0%	5.7	37.7
Structures	25.6	18.0%	4.6	30.2
Primary Structures	25.6	18.0%	4.6	30.2
Side Panel	25.6	18.0%	4.6	30.2
Mechanisms	6.3	18.0%	1.1	7.5
Installations	6.3	18.0%	1.1	7.5
GN&C Installation	0.3	18.0%	0.1	0.4
Command and Data Handling Installation	0.3	18.0%	0.1	0.6
Thermal Control Installation	5.7	18.0%	1.0	6.8
Total	127.6	18.0%	22.9	150.5

From the two MELs, the mass of the Next Generation Optical Relay Pathfinder is fairly small before fueling. A list of the properties and capabilities of the Next Generation Optical Relay Pathfinder is provided as a summary of its design.

A final summary of the Next Generation Optical Relay Pathfinder's properties and capabilities is given below:

- Crosslinks to GEO, navigation support for LEO, future lunar relay
- Two 20 cm optical units and two 10 cm optical test units on North face
- 50 Mbps Ka RF downlink for TT&C and continuous links from users to ground (no cloud outages)
- Bus S-Band for TT&C
- C&DH – High-speed, provides six minutes of buffer with three TB storage
- ACS – Sun/Earth Sensors, wheels to handle off-set solar pressure, Star trackers, provides 17.5 mrad pointing accuracy, >0.25 knowledge, < 0.1mrad jitter to optics deck
- Propulsion –hydrazine monocrop RCS (ion propulsion deemed too costly)
- Power – Single solar array, ~ 3000W EOL, Li-Ion batteries for power for transfer orbit and eclipse
- Thermal – Comm Payload Deck Radiator on North panel, Bus Radiator on south panel
- Mechanical –Array gimble, telescope two-axis gimbals
- Launcher – Atlas 411 direct to GEO (reduces s/c costs)
- Communications payload deck developed and delivered to Spacecraft vendor
- Switching modems and six TB buffer for combing uplink data for transmit to ground

5.4 Risk Assessment

Risk assessment was also performed, and the key risks are explained below in Table 9.

Table 9 Risk Assessment

Title	Risks
Gov't/Commercial Interfaces	Given that this project will assemble NASA (payload) and commercial hardware (spacecraft bus) there is a possibility of non- or ill-functioning interfaces between the spacecraft bus and science assembly which may result in loss of motion.
Off-The-Shelf (OTS) Bus	Given that we have assumed that an appropriate OTS bus exists that fulfills all the Bus requirements for our mission there is a possibility our requirements cannot be met by the OTS bus which can result in significant cost impacts.
Gimbal Drive Motor	Given that the current design includes only one solar array wing gimbal driver motor there is a possibility that the motor will fail, eliminating sun tracking by the solar array wing which can result in loss of power.
Jitter Requirements	Given that the telescope jitter requirements are very stringent there is a possibility that spacecraft vibrations may be too large, affecting that stability of the telescopes which can result in a loss of data rate.

6.0 Conclusion and Next Step

In this paper, we analyzed the feasibility of the Pathfinder for the next generation communication relay satellite through the full design process which also included cost and risk assessments. The analysis was based on the maturity of optical communication technology which has been fully demonstrated in recent optical space communication experiments. Optical communication relay appears to be doable and cost-effective.

The Next Generation relay satellite will be able to provide very high data rates to users' mission's spacecraft. The optical terminals and associated electronic equipment are going through space qualification processes. The remaining challenge will be integrating RF systems and advanced onboard processing with optical communication payload.

The next step is to mature the design of the Pathfinder for implementation in a joint effort with the industry. It will require working closely with the optical communication technology providers and satellite communication manufacturers.

7.0 Acknowledgements

The authors would like to thank Dr. Cornwell for his guidance and input on optical terminal technology and payload, as well as the technical and administrative support and Dr. Robert Manning for his help on the optical link budget tool. We appreciate the support of Mr. Badri Younes, Deputy Associate Administrator of NASA ScaN, for his direction and sponsorship. Much thanks to the COMPASS Team at NASA Glenn Research Center, who contributed to the design : Mike Bur (System Integrations, MEL, ELV Integration, Visualization); John Mudry (System Integrations, MEL, ELV Integration); David Smith (Mission); Mike Martini (AD&C); James Fittje (Propulsion); John Gyekenyesi (Mechanical systems); Tony Colozza (Thermal); James Fincannon (Power); Aimee Bogner (C&DH, Software); Bob Jones, Dr. Dan Reliable and Alan Hylton (Communications); Tom Packard (Configuration) and Elizabeth Turnbull (Cost).

8.0 References

1. "Space Communications and Navigation Networks." SCaN Media Resources, NASA, www.nasa.gov/directorates/heo/scan/services/networks/index.html
2. NASA Space Communications and Navigation Program. Public Private Partnerships to Advance Optical and RF Space Communications and Navigation (SCaN) Capabilities and Services. Request for Information (RFI). September 8th, 2017. National Aeronautics and Space Administration.
https://www.fbo.gov/index?s=opportunity&mode=form&id=b8a770a74b7042f26434780ae97e9894&tab=core&_cview=0
3. NASA Virtual Industry Forum for Public-Private Partnerships to Advance Optical and RF Space Communications and Navigations (SCaN) Capabilities and Services. September 14th, 2017. National Aeronautics and Space Administration.
https://www.fbo.gov/index?s=opportunity&mode=form&id=b8a770a74b7042f26434780ae97e9894&tab=core&_cview=0
4. NASA Space Flight Program and Project Management Requirements (NPR 7120.5)
https://nodis3.gsfc.nasa.gov/npg_img/N_PR_7120_005E_/N_PR_7120_005E_.pdf.
5. B. Younes. SCaN Next Generation Communications Capabilities, a Beacon of Light into NASA's Future. July 2017. National Aeronautics and Space Administration.
https://www.nasa.gov/sites/default/files/atoms/files/02_scan_s_next_generation_communications_capabilities_b_younes.pdf
6. D. Cornwell. NASA's Optical Communications Program for 2017 and Beyond, Advanced Communications and Navigation Division, Space Communications and Navigation, NASA HQ.
https://www.nasa.gov/sites/default/files/atoms/files/03_don_cornwell_nasas_optical_comm_program_public_release_june_2017.pdf

D. Cornwell. "NASA's optical communications program for 2015 and beyond," Proc. SPIE 9354, Free-Space Laser Communication and Atmospheric Propagation XXVII, 93540E (16 March 2015); doi: 10.1117/12.2087132
7. B. Edwards. International Interoperability Standards Development for Space Optical Communications, National Aeronautics and Space Administration.
https://www.nasa.gov/sites/default/files/atoms/files/04_international_interoperability_standards_development_for_space_optical_communications_b_edwards_web.pdf
8. Boroson, D.M. et al. "The Lunar Laser Communications Demonstration (LLCD)." Space Mission Challenges for Information Technology, 2009. SMC-IT 2009. Third IEEE International Conference on. 2009. 23-28.
9. D. Cornwell. Laser Communication Relay Demonstration Overview, Advanced Communications and Navigation Division, Space Communications and Navigation, NASA HQ.
<https://ntrs.nasa.gov/archive/nasa/casi.ntrs.nasa.gov/20160001877.pdf>
10. NASA Space Communications and Navigation Program. Next Generation Architecture Background Information. August 22nd, 2017. National Aeronautics and Space Administration.
https://www.fbo.gov/index?s=opportunity&mode=form&id=b8a770a74b7042f26434780ae97e9894&tab=core&_cview=0
11. "TDRS 11, 12, 13 (TDRS K, L, M)". https://space.skyrocket.de/doc_sdat/tdrs-11.htm