



US010145110B2

(12) **United States Patent**
Carney et al.

(10) **Patent No.:** **US 10,145,110 B2**

(45) **Date of Patent:** **Dec. 4, 2018**

(54) **DIGITAL MATERIAL ASSEMBLY BY PASSIVE MEANS AND MODULAR ISOTROPIC LATTICE EXTRUDER SYSTEM**

(71) Applicant: **Massachusetts Institute of Technology**, Cambridge, MA (US)

(72) Inventors: **Matthew Eli Carney**, Brookline, MA (US); **Benjamin Jenett**, Cambridge, MA (US); **Neil Gershenfeld**, Cambridge, MA (US)

(73) Assignee: **Massachusetts Institute of Technology**

(*) Notice: Subject to any disclaimer, the term of this patent is extended or adjusted under 35 U.S.C. 154(b) by 0 days.

(21) Appl. No.: **15/649,837**

(22) Filed: **Jul. 14, 2017**

(65) **Prior Publication Data**

US 2017/0314267 A1 Nov. 2, 2017

Related U.S. Application Data

(63) Continuation of application No. 15/035,009, filed as application No. PCT/US2016/031069 on May 5, 2016, now Pat. No. 9,809,977.

(60) Provisional application No. 62/318,891, filed on Apr. 6, 2016, provisional application No. 62/158,424, filed on May 7, 2015.

(51) **Int. Cl.**

E04C 3/02 (2006.01)
E04B 1/19 (2006.01)
B23P 19/04 (2006.01)
B64C 1/06 (2006.01)

(52) **U.S. Cl.**

CPC **E04C 3/02** (2013.01); **B23P 19/04** (2013.01); **B64C 1/068** (2013.01); **E04B 1/19** (2013.01); **B23P 2700/01** (2013.01)

(58) **Field of Classification Search**

CPC E04H 12/185; E04H 12/10; E04C 3/005; E04C 2003/0495; E04C 3/002; B64G 1/222; E04B 1/19; Y10T 29/49947; Y10T 29/49956; Y10T 29/49963

See application file for complete search history.

(56)

References Cited

U.S. PATENT DOCUMENTS

4,237,662 A * 12/1980 Kinzler B64G 9/0052/108
4,633,566 A * 1/1987 Coppa B64G 9/00244/159.4

(Continued)

Primary Examiner — Brian E Glessner

Assistant Examiner — Daniel J Kenny

(74) *Attorney, Agent, or Firm* — Flachsbarb & Greenspoon LLC

(57)

ABSTRACT

A set of machines and related systems build structures by the additive assembly of discrete parts. These digital material assemblies constrain the constituent parts to a discrete set of possible positions and orientations. In doing so, the structures exhibit many of the properties inherent in digital communication such as error correction, fault tolerance and allow the assembly of precise structures with comparatively imprecise tools. Assembly of discrete cellular lattices by a Modular Isotropic Lattice Extruder System (MILES) is implemented by pulling strings of lattice elements through a forming die that enforces geometry constraints that lock the elements into a rigid structure that can then be pushed against and extruded out of the die as an assembled, load bearing structure.

20 Claims, 16 Drawing Sheets

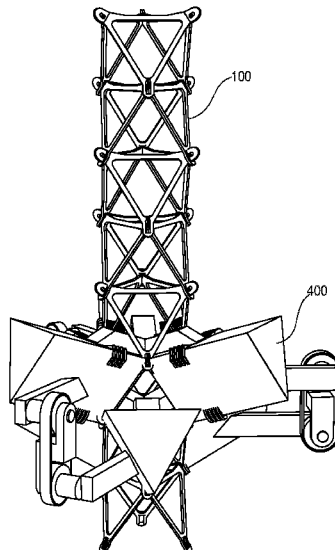

(56)

References Cited

U.S. PATENT DOCUMENTS

4,677,803 A * 7/1987 Mikulas, Jr. E04H 12/18
182/152
4,878,285 A * 11/1989 Carstensen E21B 17/042
29/451
4,920,710 A * 5/1990 Paine E04H 12/185
52/108
6,558,065 B2 * 5/2003 Huang A63H 33/04
403/170
6,711,860 B2 * 3/2004 Fleishman E04B 1/61
403/375
7,118,442 B2 * 10/2006 Laliberte A63H 33/06
446/85
7,318,303 B1 * 1/2008 Kling E04B 1/19
52/648.1
8,011,162 B2 * 9/2011 Overby E04H 12/185
52/108
8,042,305 B2 * 10/2011 Pryor B64G 1/222
244/159.4
8,381,455 B2 * 2/2013 Schooley E04H 1/1205
446/122

* cited by examiner

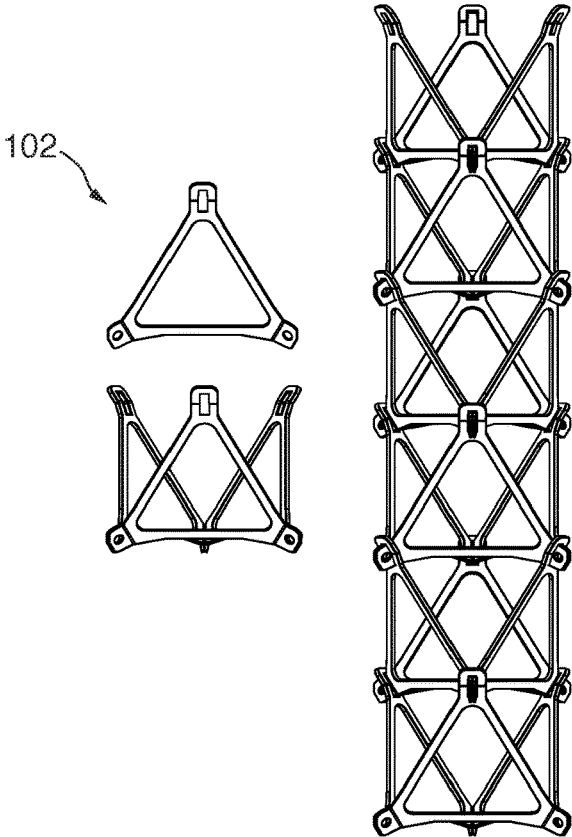

FIG. 1A

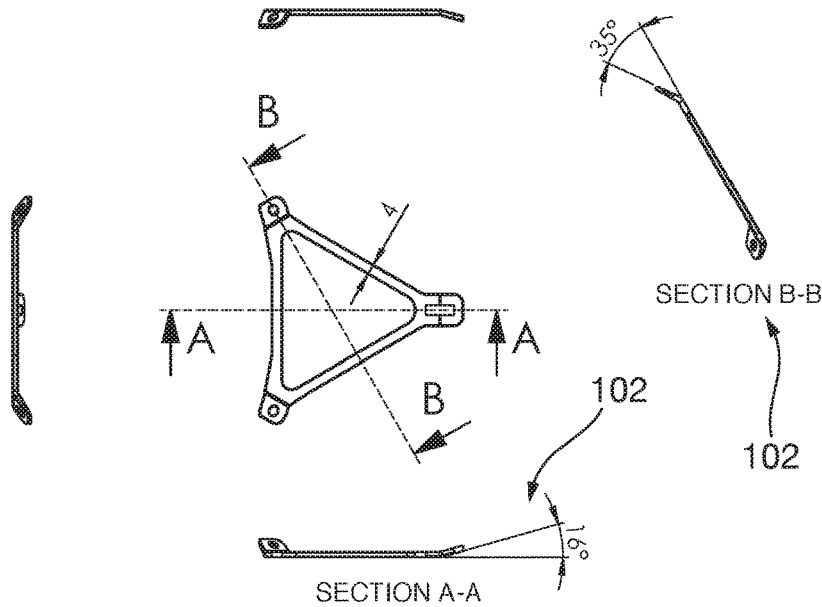

FIG. 1B

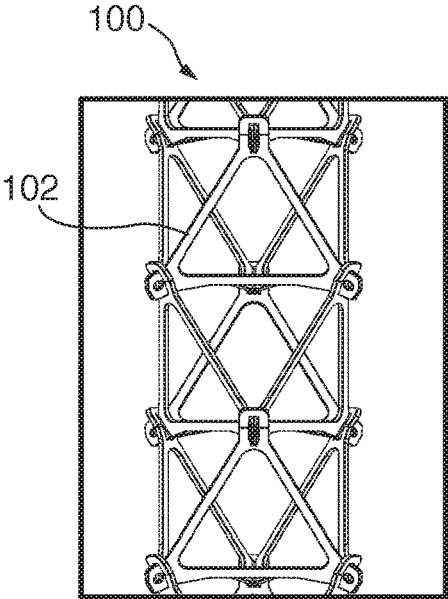

FIG. 1C

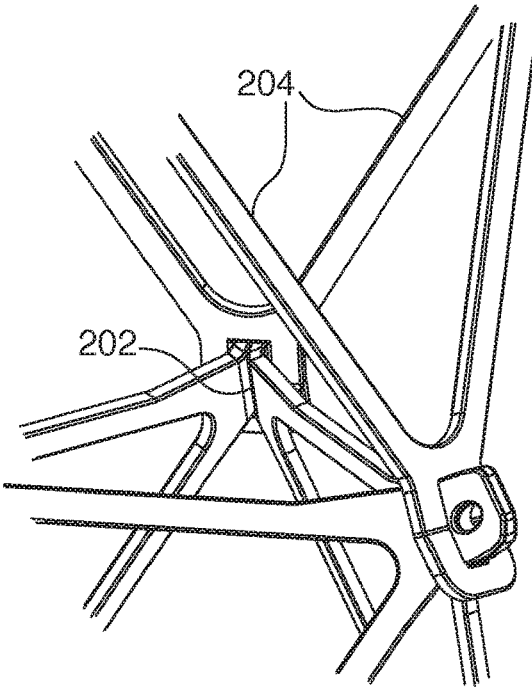

FIG. 2

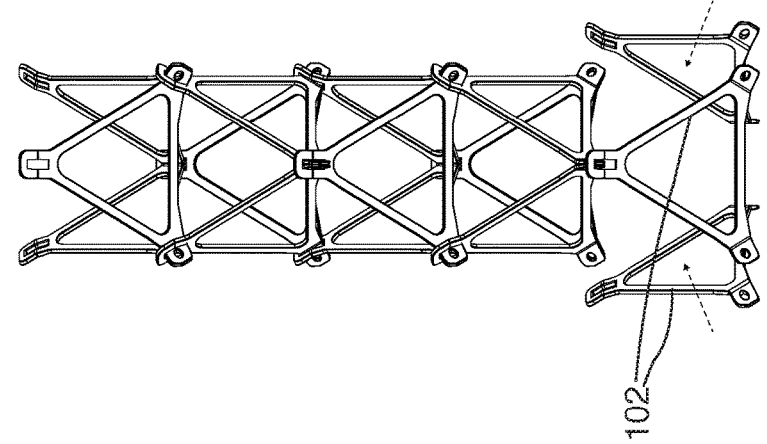
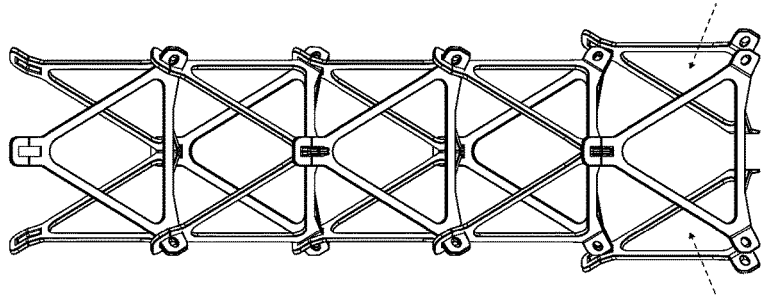
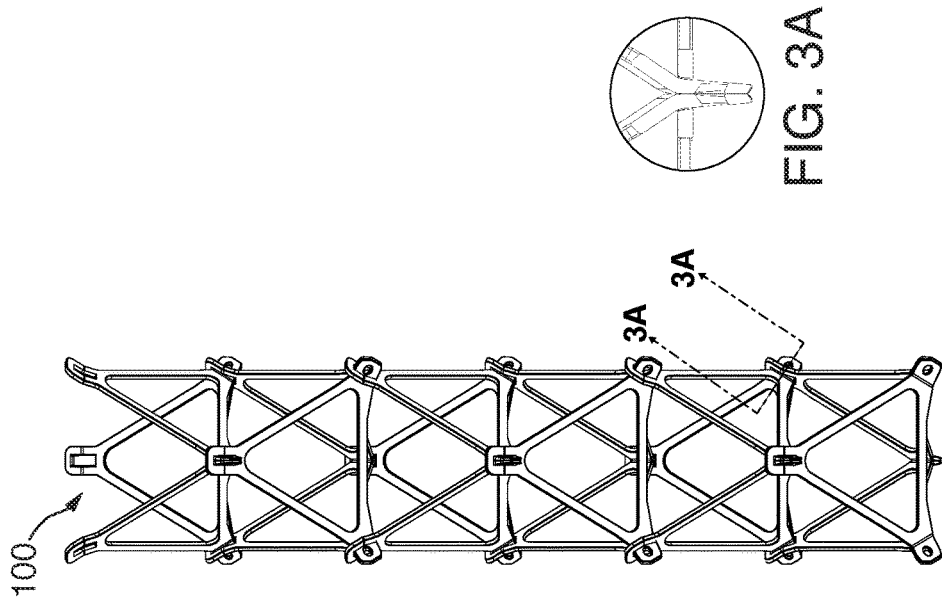

FIG. 3

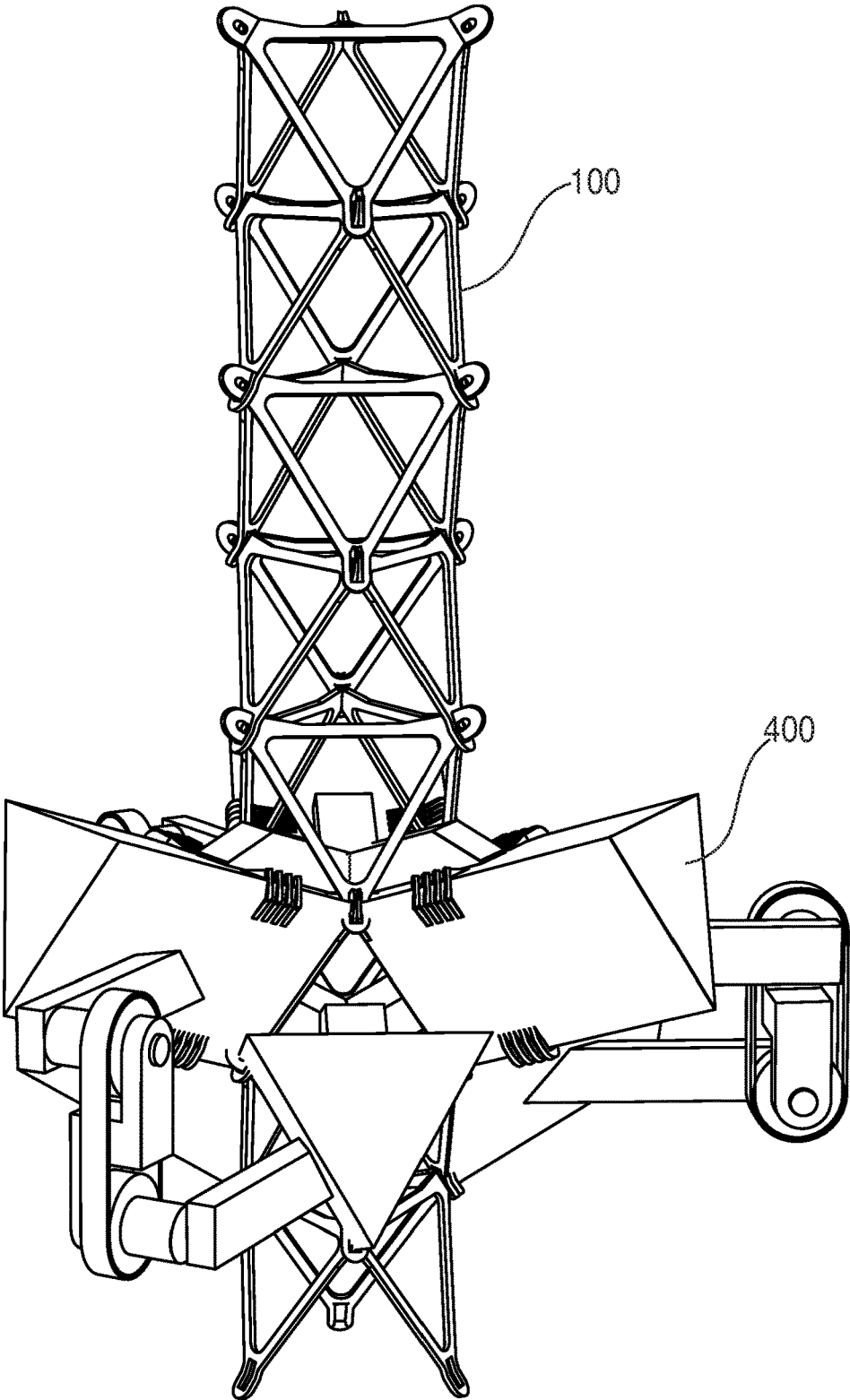

FIG. 4

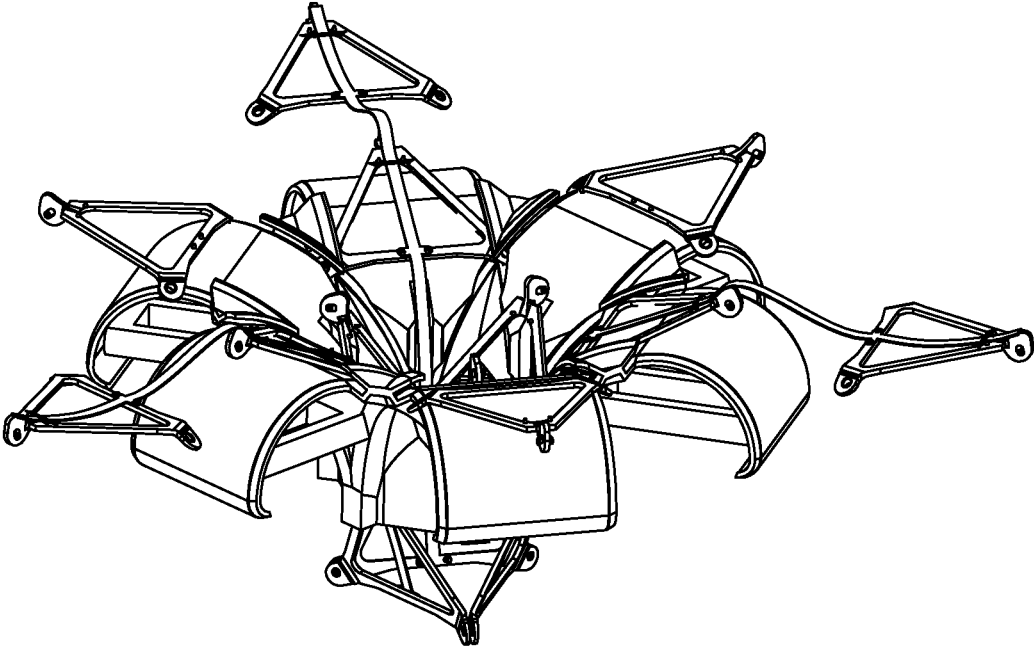
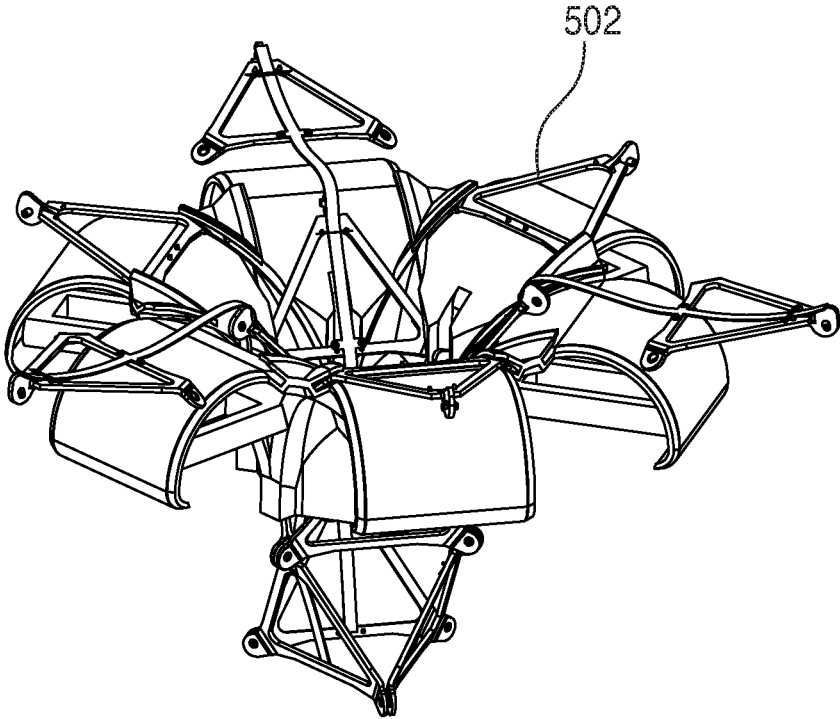

FIG. 5A

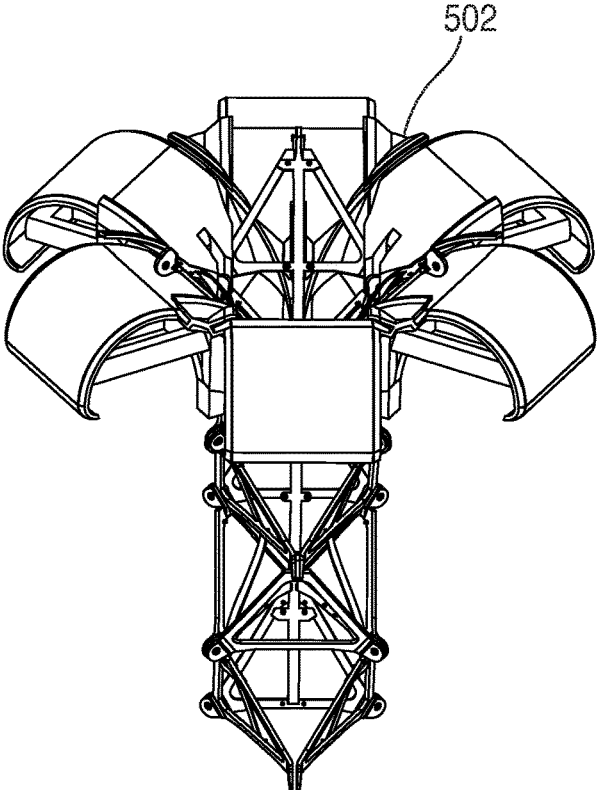

FIG. 5B

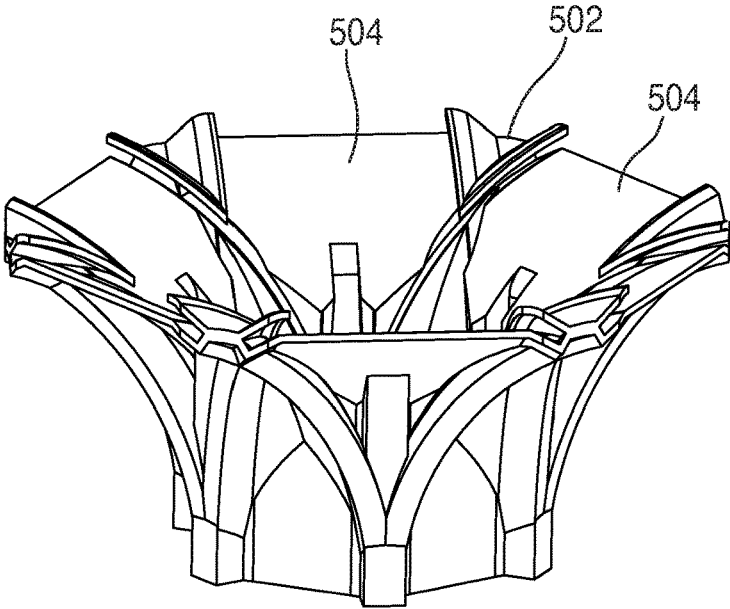

FIG. 6A

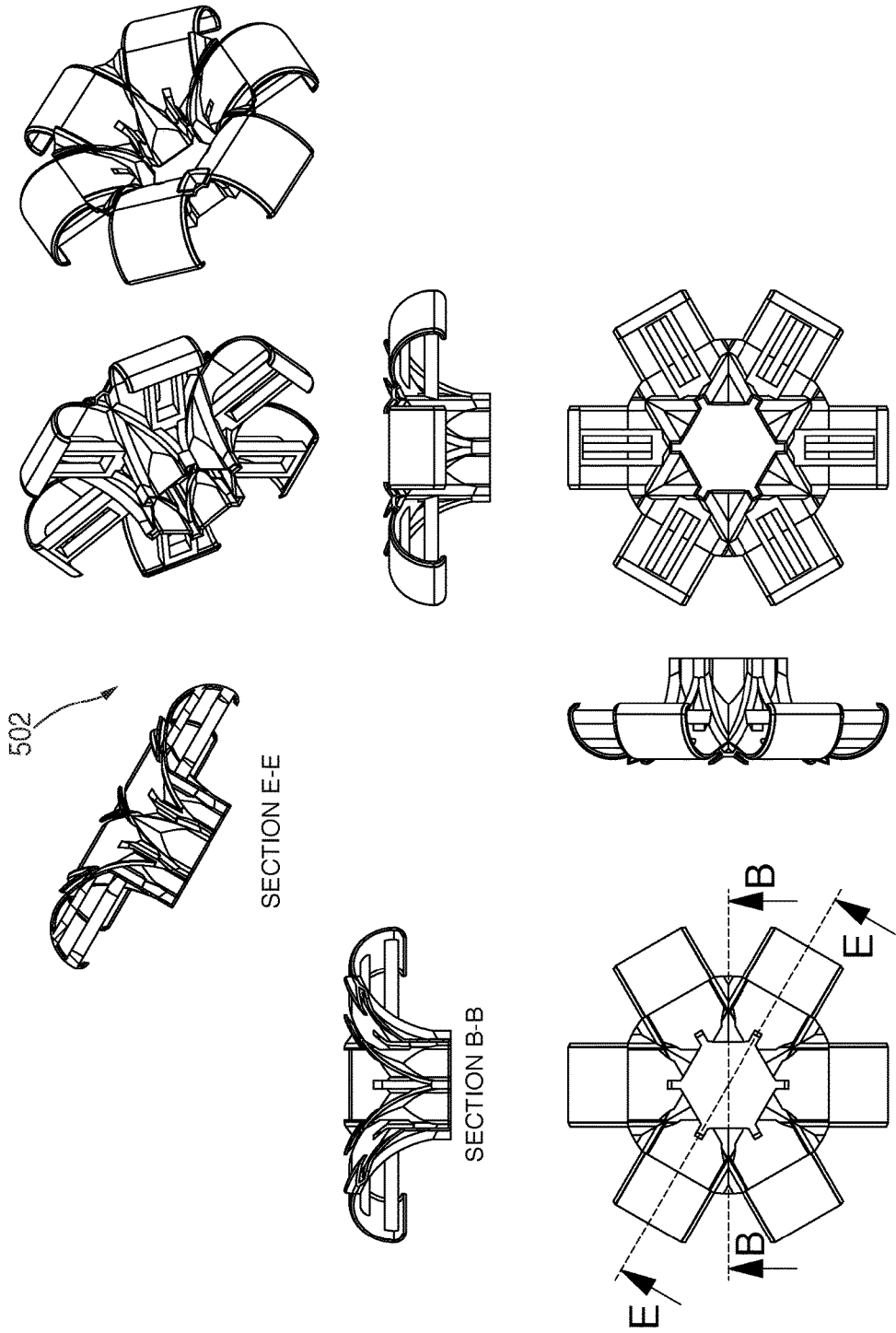

FIG. 6B

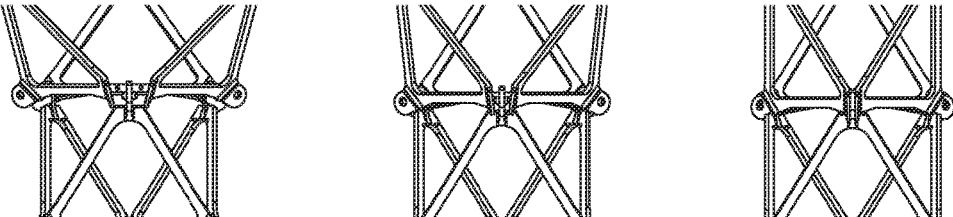

FIG. 7

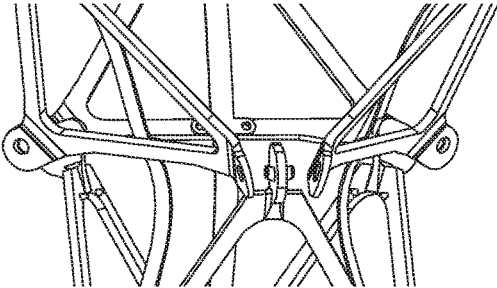
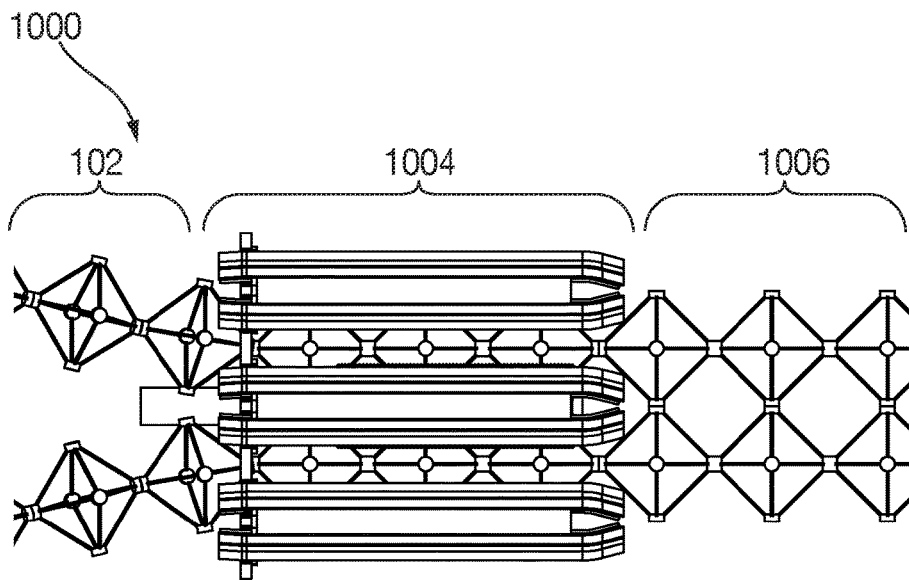
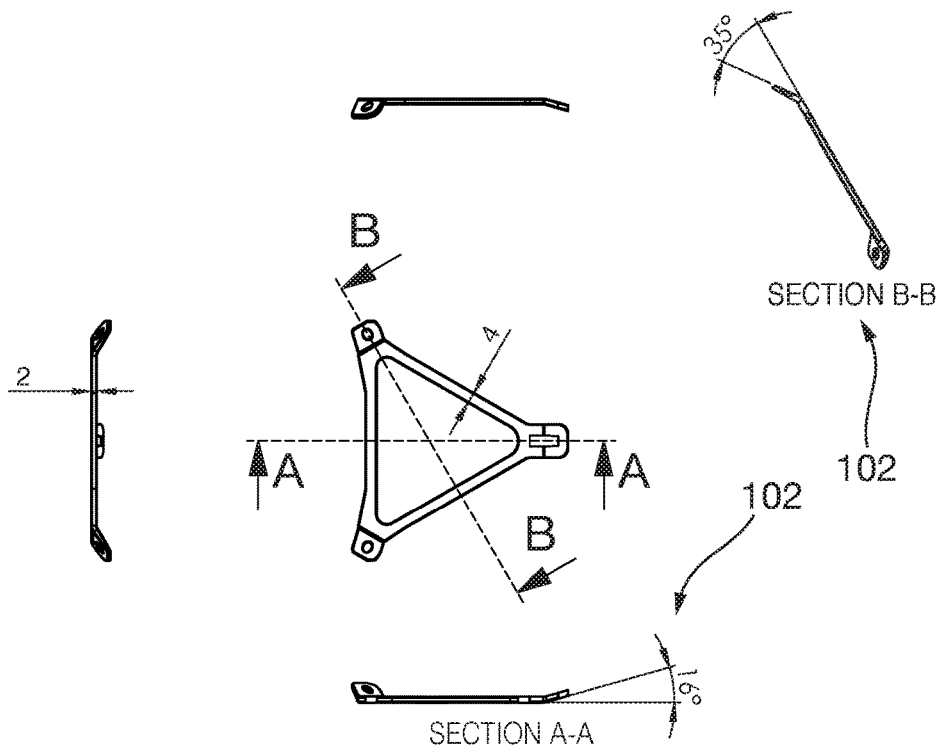

FIG. 8



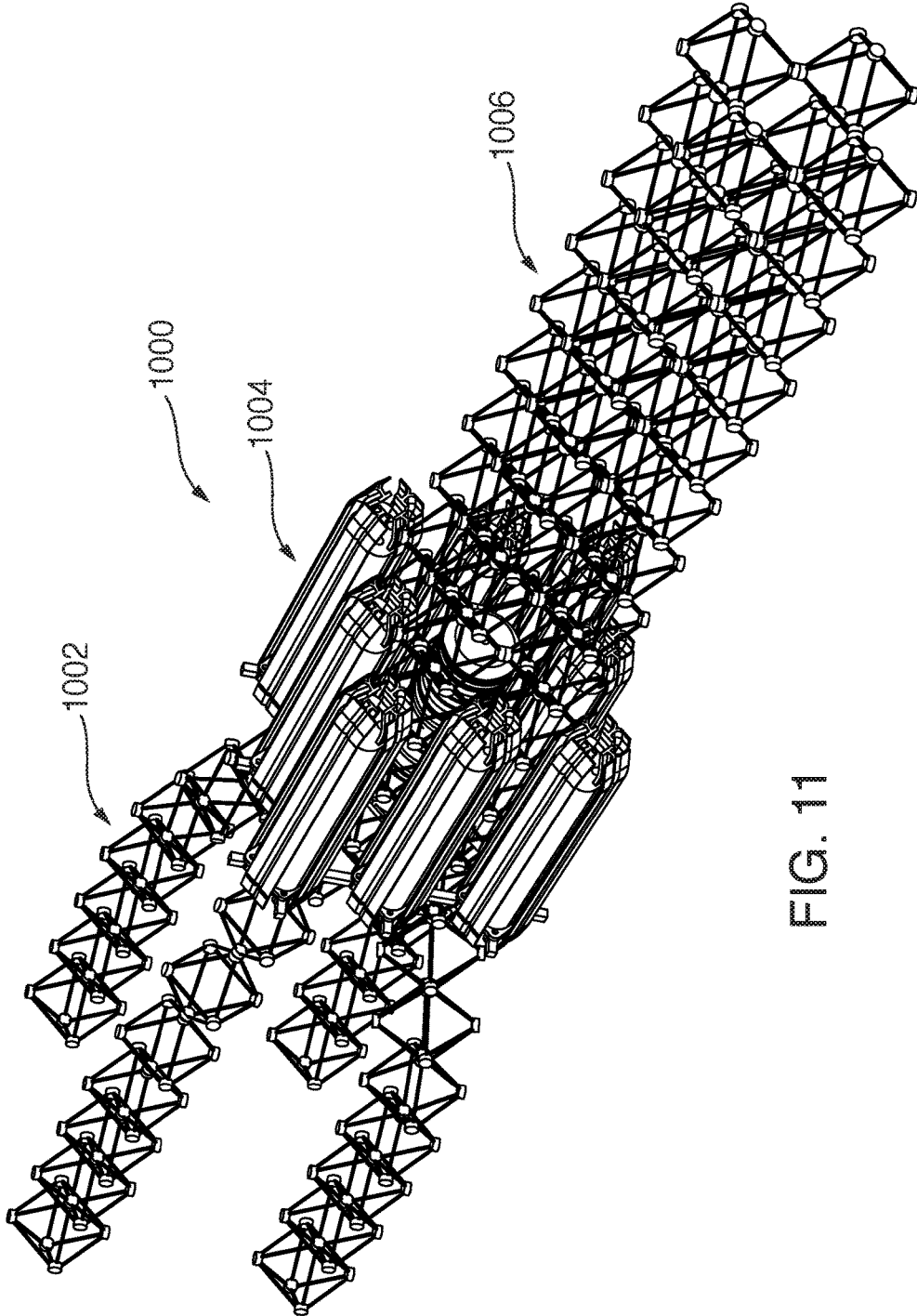

FIG. 11

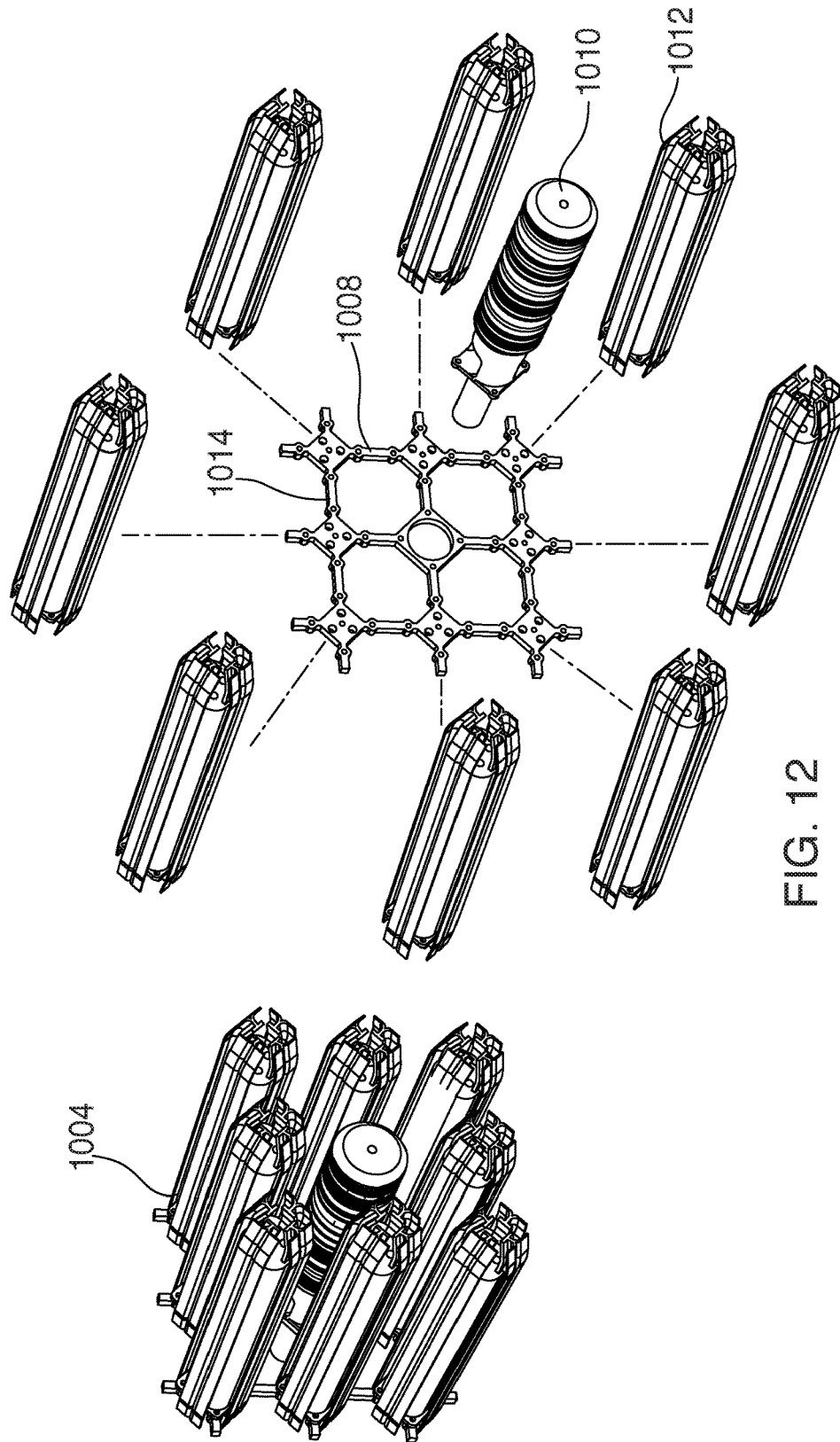

FIG. 12

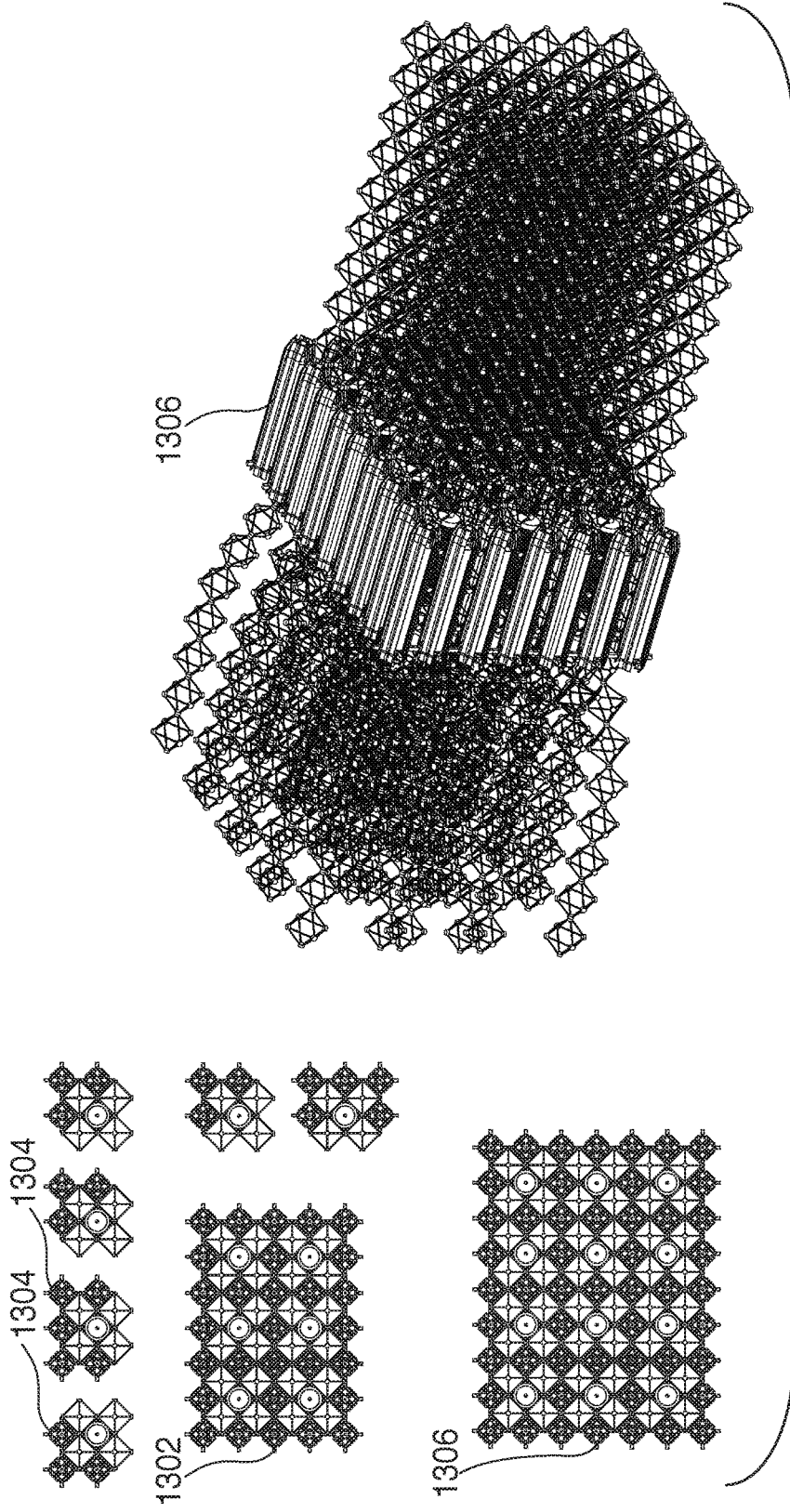

FIG. 13

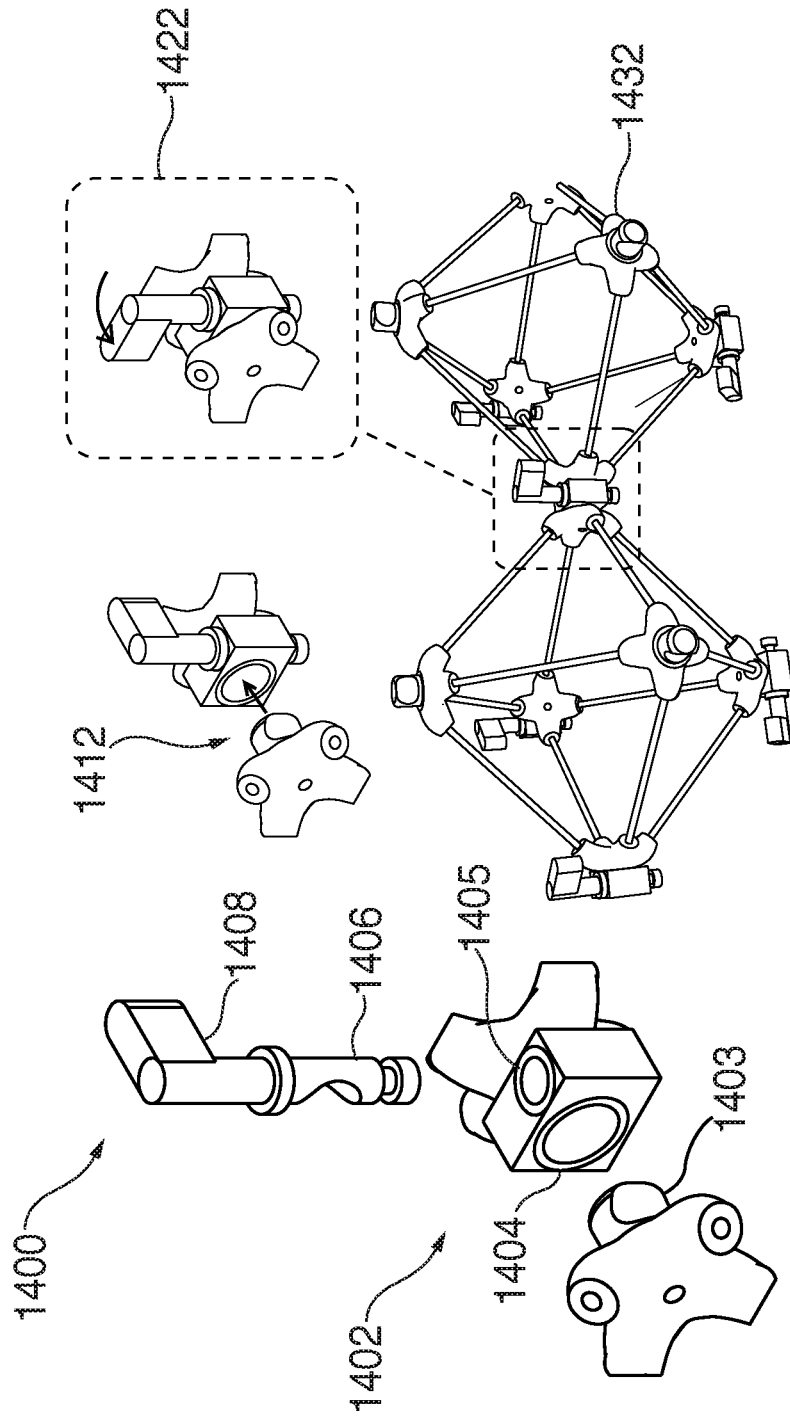

FIG. 14

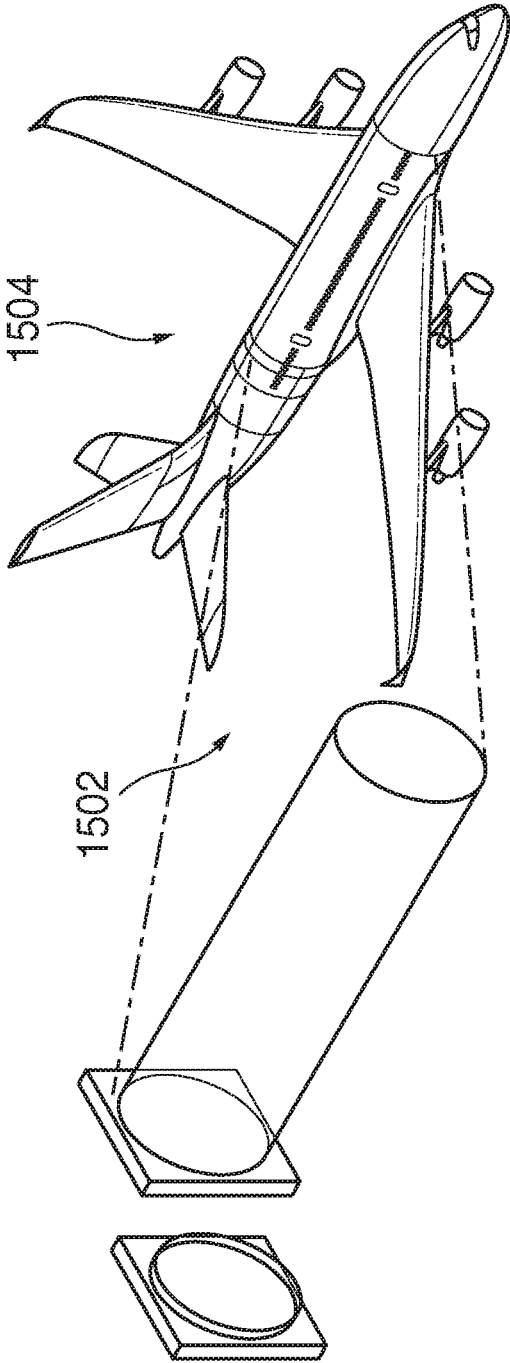

FIG. 15

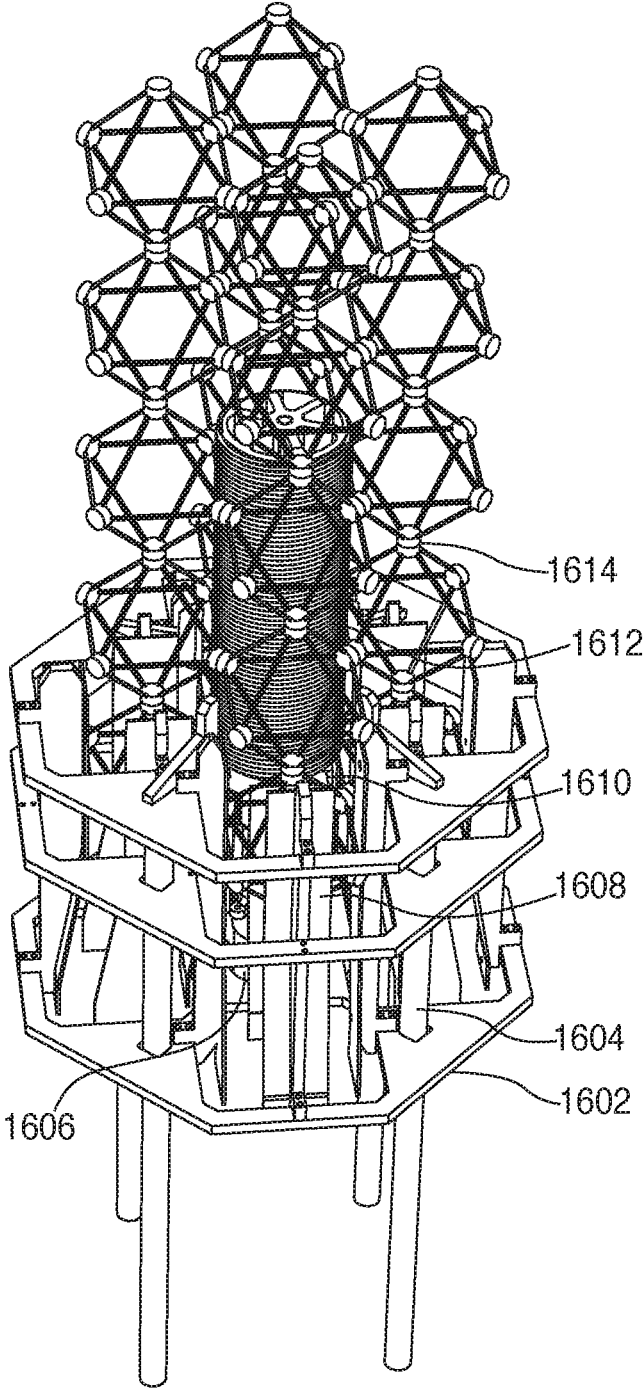

FIG. 16

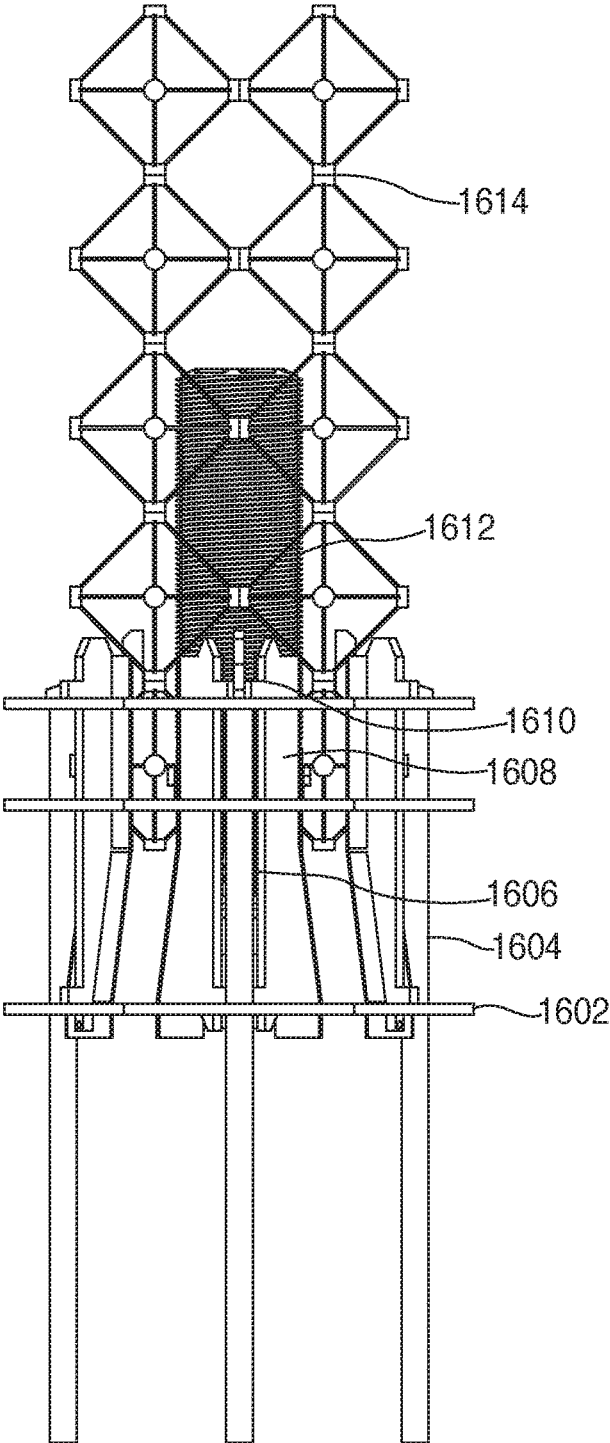

FIG. 17

DIGITAL MATERIAL ASSEMBLY BY PASSIVE MEANS AND MODULAR ISOTROPIC LATTICE EXTRUDER SYSTEM

This application is a continuation of U.S. National Stage application Ser. No. 15/035,009, filed May 6, 2016, which is a national stage application of international application No. PCT/US16/31069, filed May 5, 2016. This application claims the benefit of U.S. Provisional Application No. 62/158,424, filed May 7, 2015, and U.S. Provisional Application No. 62/318,891, filed Apr. 6, 2016, the entire disclosures of which are herein incorporated by reference.

This invention was made with government support under Grant/Contract No. NSF CMMI-1344222 awarded by NSF, Grant/Contract No. NNX14AG47A awarded by NASA, and NNX14AM40H awarded by NASA. The government has certain rights in the invention.

TECHNICAL FIELD OF THE INVENTION

The present invention relates to digital material assembly, and more specifically to digital material assembly by passive means and assembly of discrete cellular lattices.

BACKGROUND OF THE INVENTION

This invention describes a set of machines, and a structural system capable of building structures by the additive assembly of discrete parts. These digital material assemblies (described, in part, in U.S. Pat. No. 7,848,838, US20120094060, WO2014025944, US20140302261, US20140300211) constrain the constituent parts to a discrete set of possible positions and orientations. In doing so, the structures exhibit many of the properties inherent in digital communication such as error correction, fault tolerance and allow the assembly of precise structures with comparatively imprecise tools. The machines responsible for assembling digital materials should leverage, to the extent possible, the interlocking and error-correction naturally present in the discrete parts.

FIELD OF TECHNOLOGY

Prior work has been done in making machines that assemble structures from discrete parts. Hiller et al. showed a method of parallel part placement of voxel spheres in [J. Hiller and H. Lipson, "Methods of Parallel Voxel Manipulation for 3D Digital Printing," in Proceedings of the 18th solid freeform fabrication symposium, 2007, p. 12.]. These voxels, however, do not interlock in a structural way and so a binder must be used after depositing the spheres. Customizable pultrusion systems have been used for creating high performance iso-grid tubes [D. Darooka and D. Jensen, "Advanced Space structure Concepts and their development", in AIAA Structures, Structural Dynamics, and Materials Conference, 2001.]. Deployable composite structures have been used in space applications for decades, and their reliability and stiffness to weight ratio are optimized [T. Murphey, "'Booms and Trusses,'" in Recent Advances in Gossamer Spacecraft, 2006, p. 1-43.]. Few of these processes are reversible, incremental, or able to result in volumetric structures. 3D printing of lattices results in ultralight, high performance structures [X. Zheng, et al, "Ultralight, ultra stiff mechanical metamaterials," Science, vol. 344, no. 6190, pp. 1373-7, 2014.], but is not scalable beyond the printing machine. Assembled cellular lattices have been used as sandwich materials [H. Wadley, et al, "Fabrication

and Structural Performance of Periodic Cellular Metal Sandwich Structures", Composites Science and Technology, 63, p. 2331-2343, 2003.] and space filling structures [K. Cheung and N. Gershenfeld, "Reversibly assembled cellular composite materials," Science, vol. 341, no. 6151, pp. 1219-21, 2013.], but their assembly is manual and thus throughput and scale limited.

SUMMARY OF THE INVENTION

This invention describes a set of machines, and a structural system capable of building structures by the additive assembly of discrete parts. These digital material assemblies constrain the constituent parts to a discrete set of possible positions and orientations. In doing so, the structures exhibit many of the properties inherent in digital communication such as error correction, fault tolerance and allow the assembly of precise structures with comparatively imprecise tools. The machines responsible for assembling digital materials should leverage, to the extent possible, the interlocking and error-correction naturally present in the discrete parts.

A part type that demonstrates this behavior is a triangle shape. The triangle can be combined into any number of geometric shapes—cells—which when repeatedly patterned, or tiled, form rigid or deformable closed cell polyhedral volumes that make up lattice structures. A single, triangular, nearly planar part type assembles to form the four faces of a tetrahedron or the eight faces of an octahedron, or other triangulated geometries. The repeated tiling of these geometries form lattice structures whose global stiffness properties are dependent on the relative orientation of the polyhedral enclosed volumes and the connectivity of struts between the nodes of the triangles. In this manner rigid or deformable lattice structures may be constructed.

Assembly of discrete cellular lattices is implemented by three varying strategies incorporating these common features of discretely interlocked base elements.

Assembly of discrete cellular lattices is implemented by feeding (triangular) base elements from a magazine-like storage in an axially symmetric manner, their placement mechanically timed such that they form closed polyhedral when interlocked to a previously placed layer forms a rigid structure.

Assembly of discrete cellular lattices is implemented by feeding (triangular) base elements that are connected by a carrier that physically defines a distance constraint between neighboring elements such that they are pulled through a forming die that enforces further geometry constraints that lock the elements into a rigid structure.

The modular isotropic lattice extruder system (MILES) assembles discrete cellular lattices by pulling strings of lattice elements through a forming die, enforcing geometric constraints and programmatically controlled interlocking of elements into a rigid structure that can then be extruded out of the die as an assembled, load-bearing structure.

BRIEF DESCRIPTION OF THE DRAWINGS

FIG. 1A shows discrete elements arranged in cells and column motif.

FIG. 1B shows interface components.

FIG. 1C illustrates mechanical testing of column structure.

FIG. 2 illustrates a looped interface.

FIG. 3 is an assembly sequence and features of column.

FIG. 3A shows the mating of element interfaces.

FIG. 4 is an active assembler latched to structure.

FIG. 5A is a passive assembler, working on principles similar to a 3D zipper.

FIG. 5B is a passive assembler, related to FIG. 5A.

FIG. 6A is a head mandrel for the assembly of FIG. 5A or 5B.

FIG. 6B depict alternate views of the assembly head mandrel.

FIG. 7 shows the assembly sequence enforced by mandrel geometry.

FIG. 8 illustrates another interface for an alternative lattice assembly.

FIG. 9 is another view of interface components shown in FIG. 1B.

FIG. 10 is a side view of the Modular Isotropic Lattice Extrusion System (MILES).

FIG. 11 is an isotropic view of a MILES module with material feeding through the forming section.

FIG. 12 is a view of a MILES unit and an exploded view of the MILES unit.

FIG. 13 shows MILES modular scaling.

FIG. 14 shows a cam-lock interface, showing an exploded view, pre-lock, post-lock and locked voxels.

FIG. 15 illustrates the MILES system producing an air-plane fuselage.

FIG. 16 is a side view of a prototype MILES.

FIG. 17 is a front view of a prototype MILES.

DETAILED DESCRIPTION OF INVENTION

FIG. 1A shows tiles **102** in three states: alone, arranged in cells to form a volume, and as cells placed in a column motif. FIG. 1B shows these tiles as interface components **102**, isolated pre-assembly. FIG. **9** is another view of interface components shown in FIG. 1B. Note that two vertices (feet) each have a relatively small tab structure, bending out at an angle of sixteen degrees. The third vertex of the triangular tiles as depicted has a larger profile, bending out at thirty-five degrees, with a slot capable of receiving two of the smaller vertices/feet. The two smaller vertices each have apertures for receiving optimal external fasteners (discussed later). FIG. 1C illustrates mechanical testing of column structure **100**, made of interface components **102** after assembly. One embodiment of assembled triangles form stacked octahedra—an exactly constrained structural geometry. When the octahedra are assembled face to face, and placed upon the previous cell, only three triangular faces are required to effectively form the eight faces of each octahedron cell. This construction is statically and kinematically determinate following Maxwell's stability criterion; each frame consists of six joints, or nodes, connected by twelve non-collinear struts. FIG. 2 illustrates a looped interface of the two small feet engaged in a slot. Looking at it another way one node **202** is connected by six non-collinear struts **204**, exactly constraining each node **202** (FIG. 2). Adjacent elements self-align, the next element locks the previous elements together. Columns generated with this geometry form a truss structure that forms an exactly constrained, triple, co-directional cross-linked helix **100** (FIG. 1). The truss distributes axial loads into transverse loads, effectively increasing the allowable aspect ratio of the buckling criteria of the column. Columns can be assembled into multiples of volumes. Alternatively, octahedral cells may be placed in an edge connected fashion to form complex multiples of volumes while retaining the node connectivity, and stiffness.

The triangular components are designed such that load paths align directly at the interface between components. The exact point of load alignment may not necessarily reside

within the physical volume of the part, rather a virtual node may exist through which the loads effectively pass. The joint interface transmits primarily axial loads along the struts of the triangle, however it may also be designed such that moment couples are transmitted through the joint. The auxiliary geometry surrounding the interface node provides kinematic alignment features: geometry which passively, and repeatedly align the interfaces with respect to one another. In addition to alignment, the geometry at the interface also provides features for fixturing adjacent cells (FIG. 2).

Geometry of the discrete elements comprise constraints to adjacent cells that fixture their interfaces such that loads are transmitted directly through the geometry of the part. The geometry may include a feature that could be described as a loop, where material of one element surrounds the interface of at least one or more adjacent elements (FIG. 2). The loop from the next placed element locks the previously placed elements together, forming a constrained and load bearing cell. The geometry of the interface, that is the alignment of nodes, struts, alignment features and loops provides a system where tension and compression of the overall assembly both load the joint into a stable configuration such that secondary fastener components such as pins, clips, screws are not necessary. Secondary components can, though, be used to manage unexpected load conditions and for redundant connections. Pins or clips can provide additional resistance to separation of unloaded joints during torsion and bending. Traditional fastener types such as rivets or threaded interfaces may also be utilized to again provide robust fixturing.

FIG. 3 is an assembly sequence and features of the column **100**. Assembly of the parts follows a specific trajectory to allow the element interfaces **102** to mate (shown in FIG. 3A). For the loop geometry it is possible to have a trajectory that follows a single degree of freedom along the centroidal plane normal vector (FIG. 3). The combination of this trajectory, the loop interface, and the arrangement of load paths allow an assembly procedure independent of material modulus of elasticity, where elastic coupling or flexural joints are not required, nor is a secondary fastener required to transmit load. Secondary fasteners may, however, be preferred for mechanical redundancy. Complex trajectory involving at least one or more degrees of freedom may also be utilized in other embodiments where the interface fixture geometry is aligned as orthogonal as possible to all other intentional load paths of the structure. Elastic joints may also be used to interlock the interface between discrete elements and also between cells.

The part geometry may be comprised of nearly planar shapes with at least one or more bends enabling a material and process independent manufacturing process (FIG. 1). Sheet-metal, concrete, formed wood, composites, injection molding, casting, 3d printing, additive or subtractive manufacturing are examples of processes capable of producing the discrete elements. The open face circumscribed by the struts is left unadulterated to allow placement of functional components such as: skins, health monitoring, actuation, energy harvesting, lighting, etc.

Assembly of the discrete elements exploits the integration of geometry between the discrete elements and the assembler mechanisms. Alignment features are shared between the two systems to balance complexity between the part and the machine. Previous digital material assemblers specified a machine that included: a chassis, connected to a locomotion or actuation system, connected to an assembly head, and connected to a parts feeder, all of this controlled by a

computer processor. The geometry of the assembler in this embodiment integrates part feeding, locomotion, and chassis into one system. This assembler also removes the requirement for position controlled actuation, and removes the computer processor requirement; it can be driven with or without at least one prime mover. By making part placement with respect to the assembler, the number of assembler subsystems are reduced, and placement is made relative only to immediately local lattice elements, rather than discrete locations across the global structure, and the placement uncertainty is further reduced.

Three example embodiments are described that integrate multiple subsystems and remove the computer control requirement by integrating mechanical design with the periodic, structured nature of the lattice. The geometry of the assembler is designed to match the physical, periodic dimensions of the lattice. This allows mechanical timing of end-effector/foot trajectory through conventional power transmission systems (such as linkages, gears, belts, cables, track followers, hydraulics, pneumatics). Electrical timing is also possible by use of processor controlled actuators. The integration of locomotion actuation with parts placement also integrates error correction. At each step along the lattice the assembler becomes locked to the structure by attaching to either an already placed part or feeding a new part into place. The feeding mechanism is passive, such that a part is automatically driven into place by a stored energy mechanism. Parts are stored either locally in a magazine cartridge, a reel of components, remotely in a hopper type of system. Intermediate assembly mechanisms may also co-exist that allow more dense packing of discrete elements before being formed into cells to be placed. In some embodiments discrete elements may be formed into discrete cells which are then placed into the lattice.

Similar to a swiss screw machine mechanism features internal to the machine produce desired output: the timing, trajectories and forces necessary to perform the assembly or disassembly process. Mechanical timing is possible due to the periodic lattice structure and reduces the need for a computer based control system at the assembler level. In some instances it may still be beneficial to retain a computer control where sizing and integration of mechanical power transmission systems is non-trivial, or for convenience or flexibility in design.

FIG. 4 is an active assembler **400** latched to structure **100**. The active assembler **400** includes at least one or more repeating tiles **102** that latch together as they step along the lattice (FIG. 4). The foot is also the part placement, parts feeder and error correction mechanism. All operations happen internally and in parallel rather than as separate external systems, they can be mechanically or electrically driven. The feet have features (e.g., the slot in a large foot sized to receive two smaller feet) that provide kinematic alignment with the other foot mechanisms, therefore passively locating and locking each one to adjacent feet. Once located, either the new part is placed or the already placed part is locked-onto by the internal feed mechanisms, fixing the assembler to the structure. The previously placed foot of the assembler that was also attached to the previous part and adjacent feet then releases and is able to take the next step. The assembler moves the foot through a trajectory to get to the next position, this trajectory generation being comprised by conventional mechanical timing and power transmission systems. The necessary trajectory is dependent on lattice geometry and part interface design. A single prime mover, such as a motor is capable of driving the machine through the

stepping process while a series of mechanical timing mechanisms or electrically controlled actuators drive the assembly and locking chain of events.

FIG. 5A is a passive assembler, with properties similar to a so-called 3D zipper. A carrier element sets a distance constraint or timing between elements. FIG. 5B is a prototype of the passive assembler of FIG. 5A. A passive assembler relies on a three dimensional geometry of an assembly head, or a mandrel **502**, to define the path that the discrete element tracks along as it is placed or removed from the lattice (FIG. 5). FIG. 6A shows the zipper assembly head mandrel **502**. Tracks **504** in the mandrel enforce trajectory paths. FIG. 6B depict different views of the mandrel **502**. The discrete element **102** follows along the path formed into the assembly head **502**. Elements **102** are fixed in place by the placement of the following element **102**. That is, the part is only fully constrained after the placement of following adjoining parts. FIG. 7 depicts the assembly sequence enforced by mandrel **502** geometry. FIG. 8 illustrates an interface for the assembly. The trajectory necessary to mate part interfaces is iteratively defined by the interface fixturing geometry while it is itself, also, informed by the possible trajectory (FIGS. 7, 8). Control of the timing for placement is defined by a distance constraint between parts that are to be collinear in their placed configuration. The distance constraint may be established by a carrier, such as a belt, cable or chain. In this way the assembly system is similar to that of a zipper, where individual elements are constrained by their neighbors in one direction, by a carrier in the opposite direction and their assembly trajectory is defined by a physical track that the parts are pulled through. The kinematics of this assembly strategy are that of a three-dimensional zipper. A single degree of freedom is necessary to pull the zipper assembly head along the structure. This degree of freedom may be actuated by external systems, or even the mass and inertia of the motion of an initial seed assembly sequence, where gravity provides the constant pulling force that drives the elements through the assembly head. The discrete elements may be stored in a magazine, cartridge, reel or hopper type of system.

An active carrier based method of assembly is possible where the discrete elements have a distance constraint formed by a rigid intermediary component connected by pivots, composing the discrete elements into a chain. A rack and pinion type of arrangement of rollers feeds the elements into the lattice, while locomoting along the lattice. The rigid elements pivot on their integrated carrier as they roll along the rollers, similar to a chain on a sprocket. The arrangement of adjacent rollers enables connecting the chains into volume enclosing structures.

Another embodiment of the assembler trades the carrier distance constraint for a mechanical timing constraint. In this way the discrete elements require no carrier. The track still provides the passive trajectory control while an active mechanism times the dispersal of discrete elements from their storage location and along the track. The latching may be performed by tooth geometry, adhesion such as vacuum, magnetics, hook and loop, adhesive bond, etc. Upon attachment of element to lattice the latch disengages. This mechanism may also provide a locomotion system that traverses along the already formed structure, such that the assembly is capable of self locomotion along the lattice.

FIG. 10 is a side view of the Modular Isotropic Lattice Extrusion System (MILES) **1000**. MILES consists of three main components: the material feed **1002** is a chain of pre-assembled voxels, fed through a locomotion and joining assembly platform **1004**, which uses a forming die to lock

the elements together, and the final, joined, isotropic lattice **1006** which is ready for structural applications once it leaves the assembly platform **1004**. Polyhedra are pre-assembled with connections along a node or an edge such that a string, or, chain of polyhedra is formed with at least one degree of freedom remaining between each neighboring polyhedra element (FIG. 10).

FIG. 11 is an isotropic view of a MILES module with material feeding **1002** through the forming section **1004**. Four separate chains of material are seen coming into the assembly platform **1004**, and they exit as a joined, 2x2 voxel chain **1006**. This is the minimum required chain-to-structure ratio, and as a result, the assembly platform module **1004** as shown is considered the basic MILES unit.

FIG. 12 is a view of a MILES unit **1004** and an exploded view of the MILES unit **1004**. A rear mounting plate grid **1008** is the basic substructure and spacing enforcement for the MILES units. This should also be modular, so that the overall MILES system can be shaped based on functional requirements and constraints. MILES sub-modules mount directly to the grid. The locomotion module **1010** consists of a motor, whose control and power are assumed to be routed through the sub-grid **1014**. The motor is coupled to a specialized worm gear, whose pitch and diameter is designed to match the internal spacing of the lattice being constructed around it. Thus, the driving worm gear moves the structure forward, bringing in new material feed **1002** and outputting completed structure **1006**. The guide rail modules **1012** is a structural extrusion capped on all 4 sides with a low-friction contact surface (i.e.: PTFE) which guides the free material chains into their correct orientation. This guiding is critical because it lines up the nodes which are eventually forced together and joined with a reversible mechanical cam-lock interface (FIG. 14).

The chain of elements is pulled through a forming die that forces the elements into the final configuration orientated relative to neighboring strings of elements (FIGS. 10, 11, 12). In doing so, interlocking features at the nodes are forced into position. A secondary locking mechanism can then also be enforced as the nodes are dragged past a lock enforcement mechanism. One embodiment of the interlocking mechanism is shown in FIG. 14, where an eccentric self engaging cam is rotated into a locked position by a lever that is pulled past a special lock enforcement feature in the die. FIG. 14 shows a cam-lock interface **1400**, showing an exploded view **1402**, pre-lock **1412**, post-lock **1422** and locked voxels **1432**. A voxel in the material chain has a node with a male interface (**1403**). This tapered cylinder has a crescent shape cut out of it, which will be used to engage the cam-lock. It is forced by the guide rails into the neighboring voxel chain with female interfaces (**1404**). As shown in the center image, the lock pin is pre-inserted through its guide hole in the female interface (**1405**). It is kept in place by a pin feature at the bottom of the shaft (**1406**). The male interface is allowed to pass by the lock pin due to a feature in the pin (**1407**). The lock pin has a lever arm (**1408**) that is passively turned roughly 90 degrees as the material chains pass through the assembly platform. This engages a cam-locking interaction between (**1403**) and (**1407**), whereby the male interface is prevented from pulling out, and pulling on it forces the lock pin to rotate in a direction that further tightens the interface. This joint is completely reversible and because it comes pre-assembled it requires no additional hardware.

This lock enforcement feature may be active or passive such that lock engagement at specific nodes can be programmatically controlled enabling arbitrary structural

geometries to be generated, or, it may be passive in the case of constructing large bulk materials. A motion inducing mechanism then forces the already assembled, rigid, structure out of the die. This system can be constructed as a standalone module or it can then be assembled alongside other modules into extensible arrays of modules (FIG. 13).

FIG. 13 shows MILES modular scaling (L TO R). FIG. 13 depicts a 6x4 lattice extruder **1302** with additional units nearby **1304**, where the new units are added to make an 8x6 lattice extruder **1306**. The basic MILES module can be added incrementally to result in customizable MILES platforms. The direction of expansion (up, down, left right) as well as the boundary condition (side, corner) will determine the required composition of the new MILES modules (i.e.: 3 guide rails, 1 locomotion) as well as the orientation of the sub-components. This design allows a constant ratio of extruded structure to locomotion systems, ensuring that motors do not become overload and stall. Management of material feed chains will be addressed in later designs.

The extensibility of modules enables the formation of an arbitrarily sized extrusion head that has the ability to extrude, in parallel, complex, discrete cellular lattice structures (FIG. 15). FIG. 15 illustrates the MILES system producing an airplane fuselage (L to R). A large rectangular array of MILES modules **1502** is shown (material feed chains are not shown), with the desired structure extrusion profile shown emerging **1504**. The full structure is extruded and now can be extracted and used. In this case, it can be skinned and assembled to wing and fairing structures to be used as the fuselage of a plane.

As described, MILES consists of three main components: the material feed is a chain of pre-assembled voxels, fed through a forming die that locks the elements together, and is fed by motion mechanism.

The pre-assembled voxel chains are fed into the MILES platforms with a specific distance constraint defining the spacing between the elements. In other systems, such as the standard zipper, the locking components are fed along a secondary tensile carrier that enforces the distance constraint. In MILES the interlocking elements are integral to the structural lattice itself, reducing the feed stock to a single type of feed element.

Upon entering the locomotion and joining station, they are forced into their final configuration by guide rails that are essentially a forming die. This forming die may be constructed as a modular system attached to a gridded support structure. The two universal cartridge types are the driver cartridge or motion mechanism, and, the rail cartridge. In one embodiment the driver cartridge consists of a motorized screw drive that pushes along the rigidly assembled structure. The rigidly assembled structure, still being attached to the feedstock, pulls the feedstock into the forming module as it is pushed out of the module. The rail cartridge has 4 guide rails to support the feed stock from all necessary directions such that a single drive mechanism can push four strings of feedstock (FIG. 12).

Next, the passive locking feature that rigidly constrains the neighboring strings is actuated, reversibly connecting the parts without any need for external hardware, as it passes by an actuating feature along its way through the forming die. The design for this locking feature is based on a self-tightening cammed pin (this locking mechanism is similarly used in triple for attaching a chuck to the spindle of a lathe (FIG. 14)) with a tab that is pushed by a passive feature on the machine. Tapered leading edges on the male interface help with alignment, and the locking pin is captive, not external. Pin rotation occurs passively as the elements are

pulled past a tab feature on the extrusion head that forces the lever arm of the pin to rotate. Motion of the voxel elements is provided by central locomotion worm gear pushing on the already assembled rigid structure.

What is further unique to MILES is its modularity. The basic MILES unit can extrude a 4-voxel (2x2) lattice, and to do so uses 8 guide rail modules and a single central locomotion module. These modules are designed to mount to a rear mounting plate grid, which can be of any dimension necessary. This modular system enables simplified expansion with the addition of more modules. This allows customized extruder platforms to be quickly setup without relying on monolithic gantry-type elements. This way it will be possible to extrude large high performance structures such as aerospace components.

FIG. 16 and FIG. 17 are a side and front view, respectively, of a prototype MILES. Shown is rear mounting plate grid (1602), guide rail structure (1604), motor (1606), guide rail surfaces (1608), passive cam-lock enforcement armature (1610), worm gear material feed locomotion mechanism (1612), and assembled structure with locked joints (1614).

While the above specification and examples provide a description of the invention, many embodiments of the invention can be made without departing from the spirit and scope of the invention. It is to be understood that the foregoing embodiments are provided as illustrative only, and does not limit or define the scope of the invention. Various other embodiments are also within the scope of the claims.

What is claimed is:

1. An assembly method of constructing a lattice structure, the lattice having physical, periodic dimensions, the method comprising:

connecting together along respective nodes, tiles formed of a single geometric shape such that the connected tiles enclose a lattice volume, wherein the respective nodes comprise a loop interface feature whereby a node of one tile surrounds at least part of the node of one or more adjacent tiles; and

repeating the connecting step by adding new tiles to unconnected nodes of the previously connected tiles to define the lattice volume, such that the lattice volume grows in a single direction along the centroidal axis shared by stacking the tiles;

wherein at least one vertex of the tiles has a small tab structure bending outward from the centroidal axis at an angle, and an aperture for receiving external fasteners;

wherein at least one vertex of the tiles has a tab structure larger than the small tab structure bending out at an angle, the larger tab having a slot capable of receiving a plurality of vertices with the small tab structure;

wherein each tile is automatically driven into place by a stored energy mechanism.

2. The method of claim 1, wherein the at least one vertex having the small tab structure bends outward from the centroidal axis at an angle of approximately sixteen degrees.

3. The method of claim 1, wherein the at least one vertex having the larger tab structure bends outward from the centroidal axis at an angle of approximately thirty-five degrees.

4. The method of claim 1, wherein adjacent nodes align with the next node locking previous nodes together.

5. The method of claim 1, whereby the single geometric shape formed has a constrained structural geometry.

6. The method of claim 1, wherein the external fasteners are pins or clips that provide additional resistance to separation of unloaded joints during torsion and bending.

7. The method of claim 1, wherein the external fasteners are rivets.

8. The method of claim 1, wherein the external fasteners are threaded interfaces.

9. The method of claim 1, wherein each node is connected by noncollinear struts, exactly constraining each node.

10. The method of claim 9, wherein an open face circumscribed by the struts is configured to allow placement of functional components such as skins, health monitoring, actuation, energy harvesting, and lighting components.

11. The method of claim 1, wherein structural geometry of the assembly method matches the physical, periodic dimensions of the lattice, allowing mechanical timing of foot trajectory through conventional power transmission systems such as linkages, gears, belts, cables, track followers, hydraulics, and pneumatics.

12. The method of claim 1, wherein the integration of locomotion actuation with parts placement integrates error correction.

13. The method of claim 1, wherein at each step along the lattice, an assembler locks to the lattice by attaching to either an already placed part, or feeding a new part into place.

14. The method of claim 1, wherein intermediate assembly mechanisms allow dense packing of discrete elements before being formed into cells to be placed on the lattice.

15. The method of claim 1, wherein separate elements are formed into discrete cells which are subsequently placed into the lattice.

16. The method of claim 15, wherein elastic joints interlock the interface between said discrete elements and also between cells of the lattice.

17. The method of claim 1 wherein said tiles are triangular.

18. The method of claim 1 wherein said tiles are planar.

19. An assembly method of constructing a lattice structure, the lattice having physical, periodic dimensions, the method comprising:

connecting together along respective nodes, tiles formed of a single geometric shape such that the connected tiles enclose a lattice volume, wherein the respective nodes comprise a loop interface feature whereby a node of one tile surrounds at least part of the node of one or more adjacent tiles; and

repeating the connecting step by adding new tiles to unconnected nodes of the previously connected tiles to define the lattice volume, such that the lattice volume grows in a single direction along the centroidal axis shared by stacking the tiles;

wherein at least one vertex of the tiles has a small tab structure bending outward from the centroidal axis at an angle, and an aperture for receiving external fasteners;

wherein at least one vertex of the tiles has a small tab structure bending outward from the centroidal axis at an angle, and an aperture for receiving external fasteners;

wherein at least one vertex of the tiles has a tab structure larger than the small tab structure bending out at an angle, the larger tab having a slot capable of receiving a plurality of vertices with the small tab structure; and wherein, a modular isotropic lattice extruder system assembles the lattice structure by pulling strings of the tiles through a forming die, interlocking the tiles into a rigid final structure that can then be extruded out of the die as an assembled, load-bearing structure.

20. An assembly method of constructing a lattice structure, the lattice having physical, periodic dimensions, the method comprising:

connecting together along respective nodes, tiles formed of a single geometric shape such that the connected tiles enclose a lattice volume, wherein the respective nodes comprise a loop interface feature whereby a node of one tile surrounds at least part of the node of one or more adjacent tiles; and

repeating the connecting step by adding new tiles to unconnected nodes of the previously connected tiles to define the lattice volume, such that the lattice volume grows in a single direction along the centroidal axis shared by stacking the tiles;

wherein at least one vertex of the tiles has a small tab structure bending outward from the centroidal axis at an angle, and an aperture for receiving external fasteners;

wherein at least one vertex of the tiles has a tab structure larger than the small tab structure bending out at an angle, the larger tab having a slot capable of receiving a plurality of vertices with the small tab structure.

* * * * *