

# Space Technology Mission Directorate

## Game Changing Development Program

### Autonomous Lunar Solar Array (ALSA)

#### 2018 Big Idea Challenge Interns

### Goal

NASA has aimed its sights towards sending humans back to the moon to develop and test technologies needed for future deep space exploration. Permanent power generation structures will play a key role in establishing habitat and in-situ resource utilization (ISRU) structures. Our group, part of the NASA Big Idea Challenge, came up with a concept for a solar array large enough to power a habitat, ISRU activities, and rover exploration in permanently shadowed lunar craters at the lunar poles.

### Big Idea Challenge Team

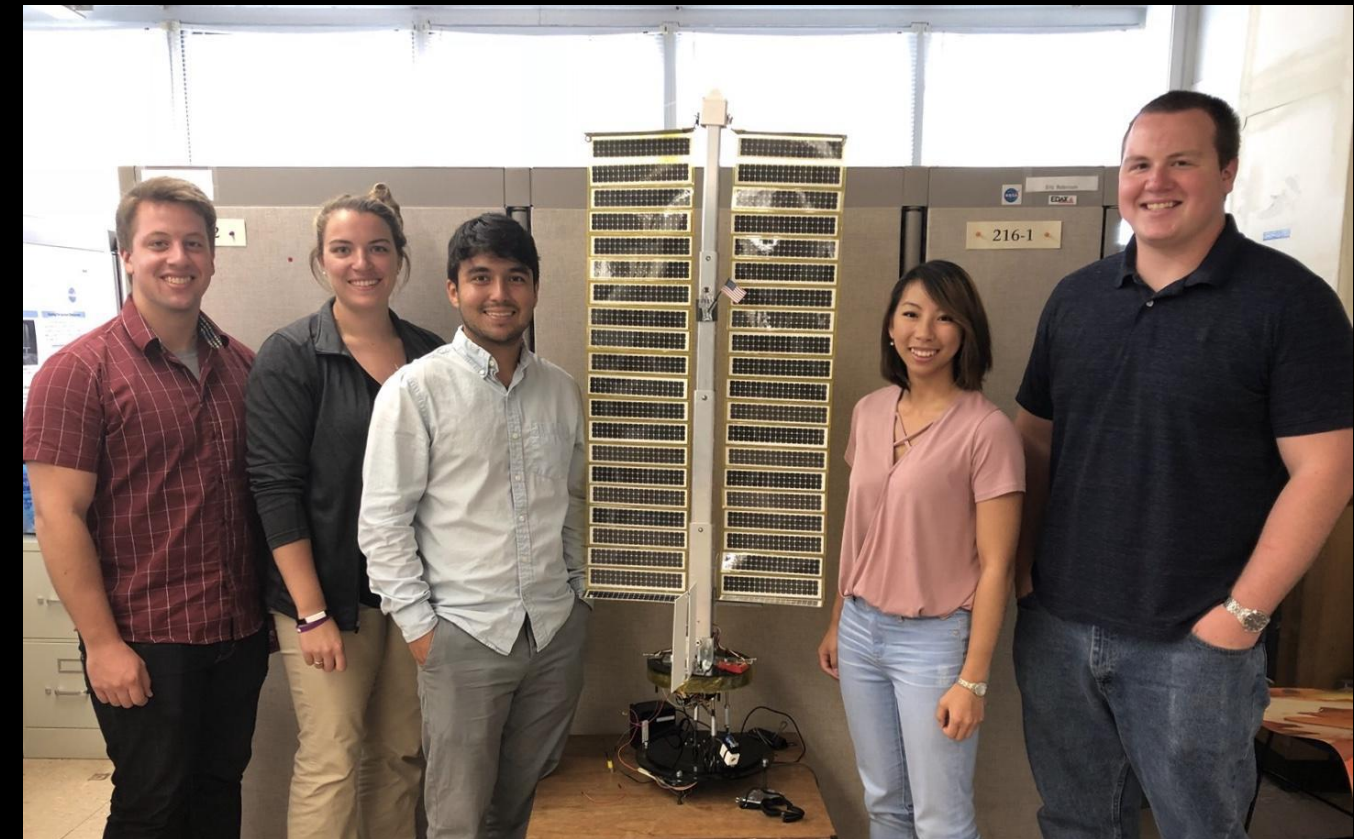

Big Idea Challenge Interns. Pictured left to right: Eric Robinson<sup>2</sup>, Laurie King<sup>1</sup>, Nick Glascock<sup>2</sup>, Charlene Huyler<sup>1</sup>, Tyler Azure<sup>1</sup>.  
1: Norwich University: Northfield, VT  
2: University of Colorado: Boulder, CO

Mentor: Jeremiah McNatt / GRC  
PM: Fred Elliott / GRC

### Functional Model

The Autonomous Lunar Solar Array (ALSA) utilizes a Compact Telescoping Array developed by Orbital ATK, Angstrom Designs and NASA LaRC, in combination with a stepper motor solar tracker and a simple two-axis leveling system. These allow for low system mass, maximum power generation, and slope compensation.

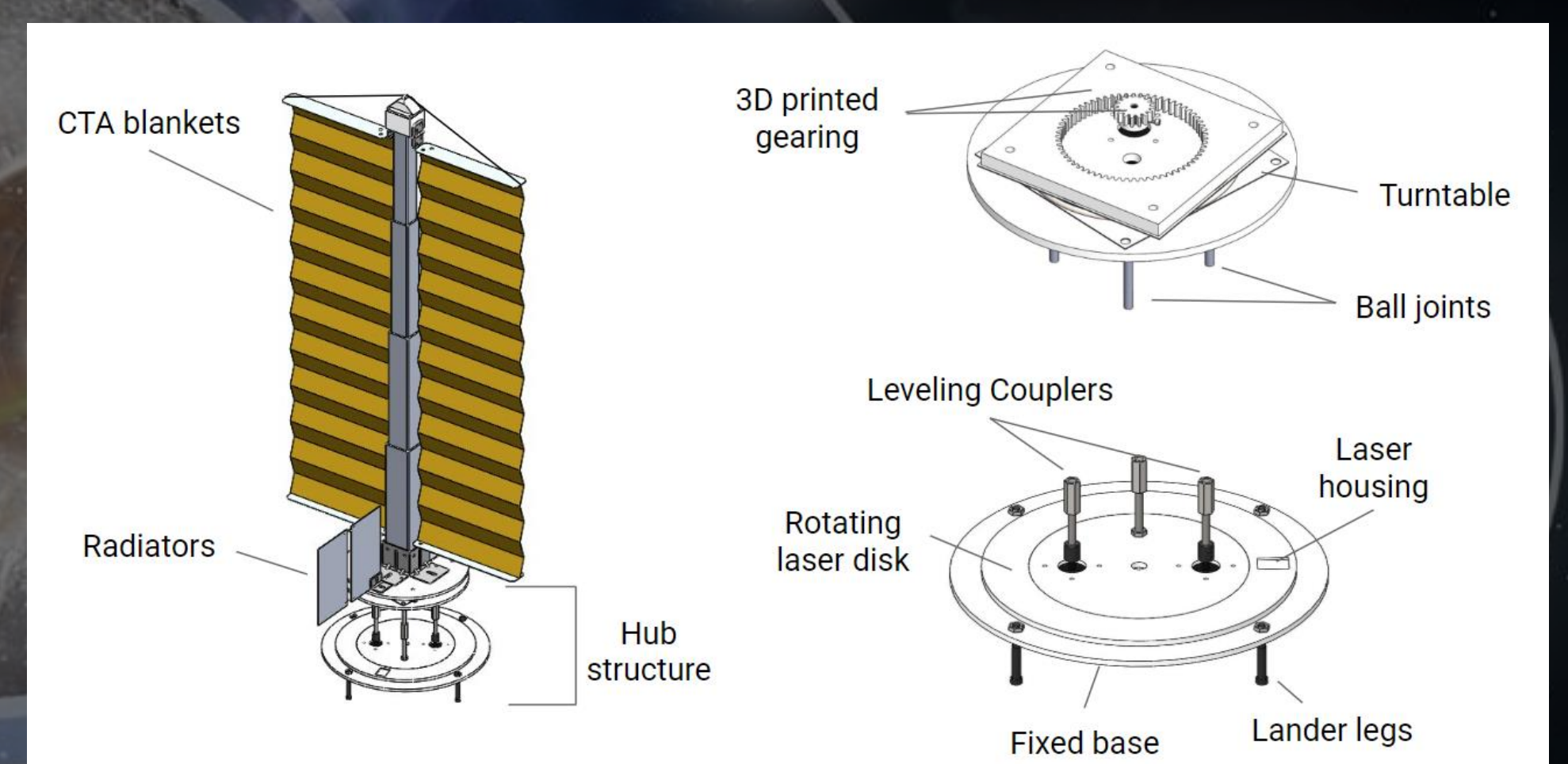

Scaled model demonstrating general functionality of the design concepts. Utilizes readily available COTS parts for time and cost.

### Design Components

- **Compact Telescoping Array (CTA)**

Adapt horizontal CTA to a vertical structure. Solar cell blankets unfold as telescoping truss booms deploy vertically

- **Solar Tracking and Leveling System**

Stepper motor with internal-gear slew bearing for tracking and three electromechanical actuators to provide two-axis leveling

- **Power Beaming - Crater Ridge to Base**

Beam combined fiber laser sends energy to receiving solar array on a rover to power instrumentation



- **Passive Cooling System**

Utilizes aluminum radiators and variable conductance heat pipes (VCHP) to dissipate heat

### Leveled Model

