



National Aeronautics and
Space Administration



EcAMSat Spacecraft Mission: The Success Story of NASA's First 6U CubeSat

Stevan Spremo

EcAMSat Project Manager

NASA ARC



National Aeronautics and
Space Administration



BACKGROUND

NASA Ames Biological NanoSat History

- **StarDotSat Bus**
 - Developed by Stanford University
- **NASA NanoSat Bus 1.0**
 - GeneBox (2006)
 - GeneSat (2006)
 - First NASA Cubesat
 - PreSat & NanoSail-D (2008)
 - LV Failed To Reach Orbit
 - PharmaSat (2009)
 - O/OREOS (2010)
 - NanoSail-D2 (2010)
 - EcAMSat (2017) First NASA 6U
- **Core team members had extensive Small Satellite Experience**

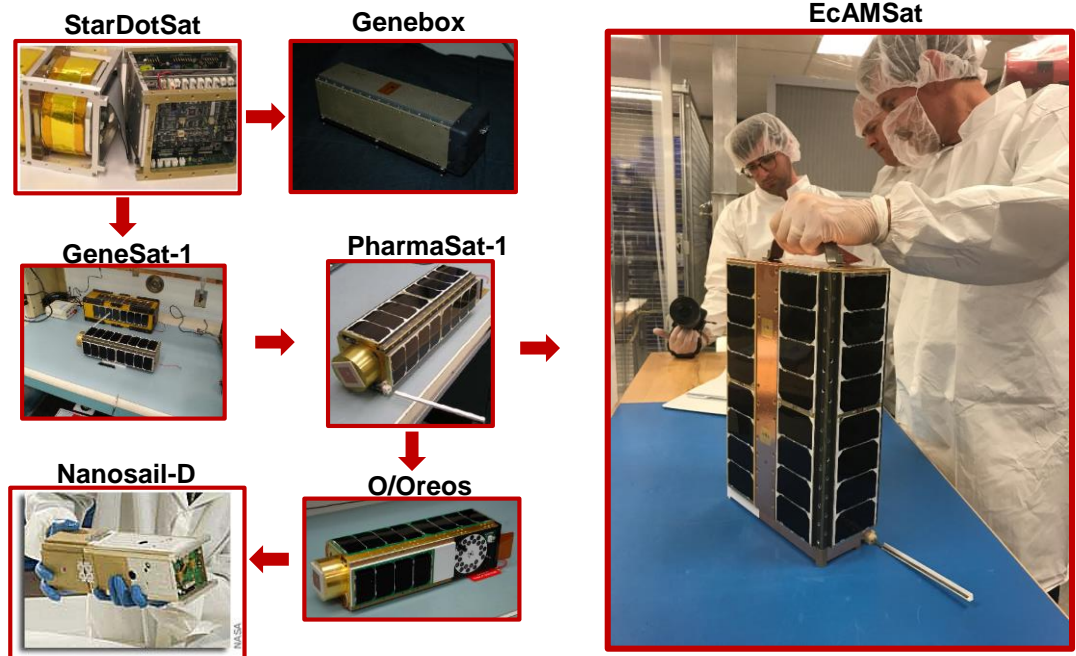



EcAMSat History

- **Spaceflight Effects on Bacterial Antibiotic Resistance and Its Genetic Basis “AntiMicrobialSat”**
 - Originally Proposed to NASA in December 2009
- **MisST Mission of Opportunity “Mo01” Payload “PharmaSat II”**
 - Science Requirements Review (ScR) - 27 October 2010
- **Mission of Opportunity - Mo01 “AntiMicrobialSat”**
 - Phase A Review – 18 March 2011
- **EcAMSat**
 - PDR – 28 February 2013
 - CDR – 4 September 2013
 - Flight Hardware Available (FHA) Review – 5 June 2014 (Spacecraft Ready for Launch and NASA HQ requested to place in storage awaiting launch opportunity)
 - **Manifested on SpaceX FormoSat-5 – October 2014**
 - Place EcAMSat Spacecraft in storage to conserve funding “Pre-Storage Review” – 2 December 2015
 - **De-manifested from SpaceX – January 2017**
 - **Manifested on OA-8E – May 2017**
 - Mission Readiness Review – 18 October 2017
 - Nanoracks Integration October 25, 2017
 - Launch November 12, 2017
 - ISS Deployment November 20, 2017
 - Mission Outbrief – 6 March 2018

Scientific Background

EcAMSat Principal Investigator: Dr. AC Matin, Stanford University

- **The EcAMSat science objective is to investigate the effect of microgravity on the resistance of the uropathogenic strain of Escherichia coli (UPEC) to an appropriate antibiotic and the role of a gene previously identified with respect to antibiotic resistance in this bacterium.**
- **Human immune response is compromised in microgravity**
- **EcAMSat looked at this problem for E. coli, (uropathogenic Escherichia coli)**
 - UPEC causes urinary tract infections
 - The antibiotic used in EcAMSat (gentamicin) is used to treat UTI's and was chosen for this experiment
- **Does E. coli gentamicin resistance change in microgravity, in wild-type strains as well as in $\Delta rpoS$ mutant strains?**
- **Alternating wells loaded with WT and $\Delta rpoS$ mutant strains**
- **Each bank receives a different antibiotic dose (control, low, medium, high)**

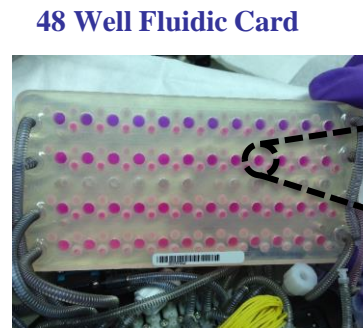

Cross section of 1 well

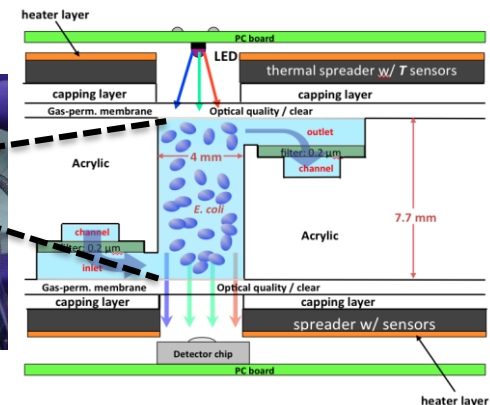



National Aeronautics and Space Administration



Discovery • Innovations • Solutions

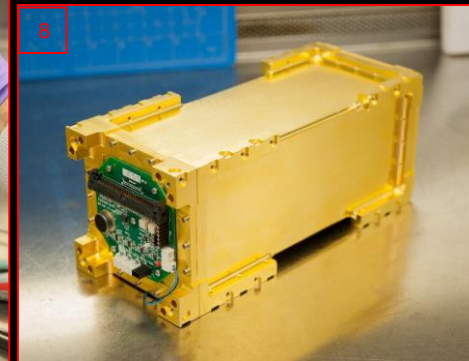
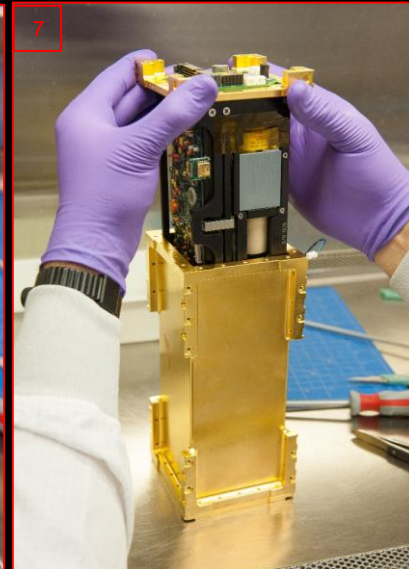
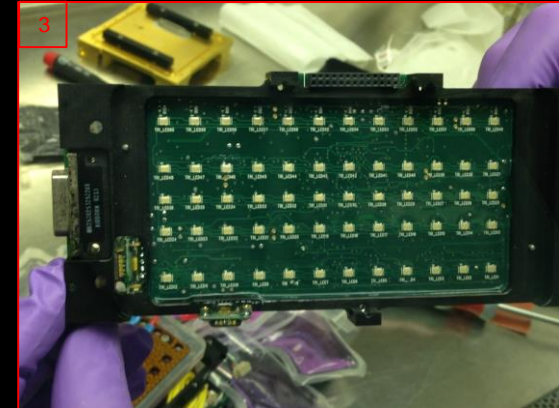
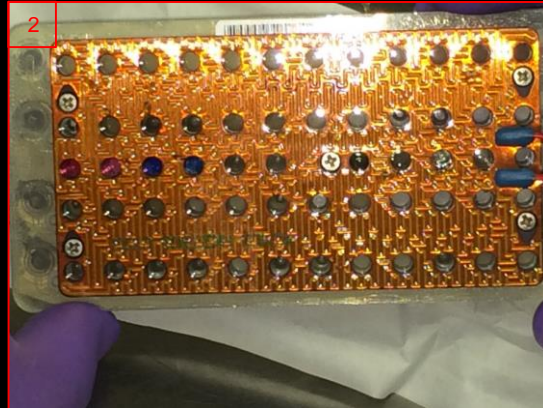
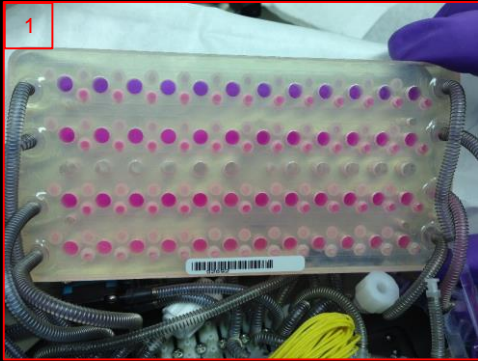

NASA Facebook Live Payload Explanation:
<https://www.facebook.com/nasaames/videos/10154737475201394/>



EcAMSat Payload Configuration

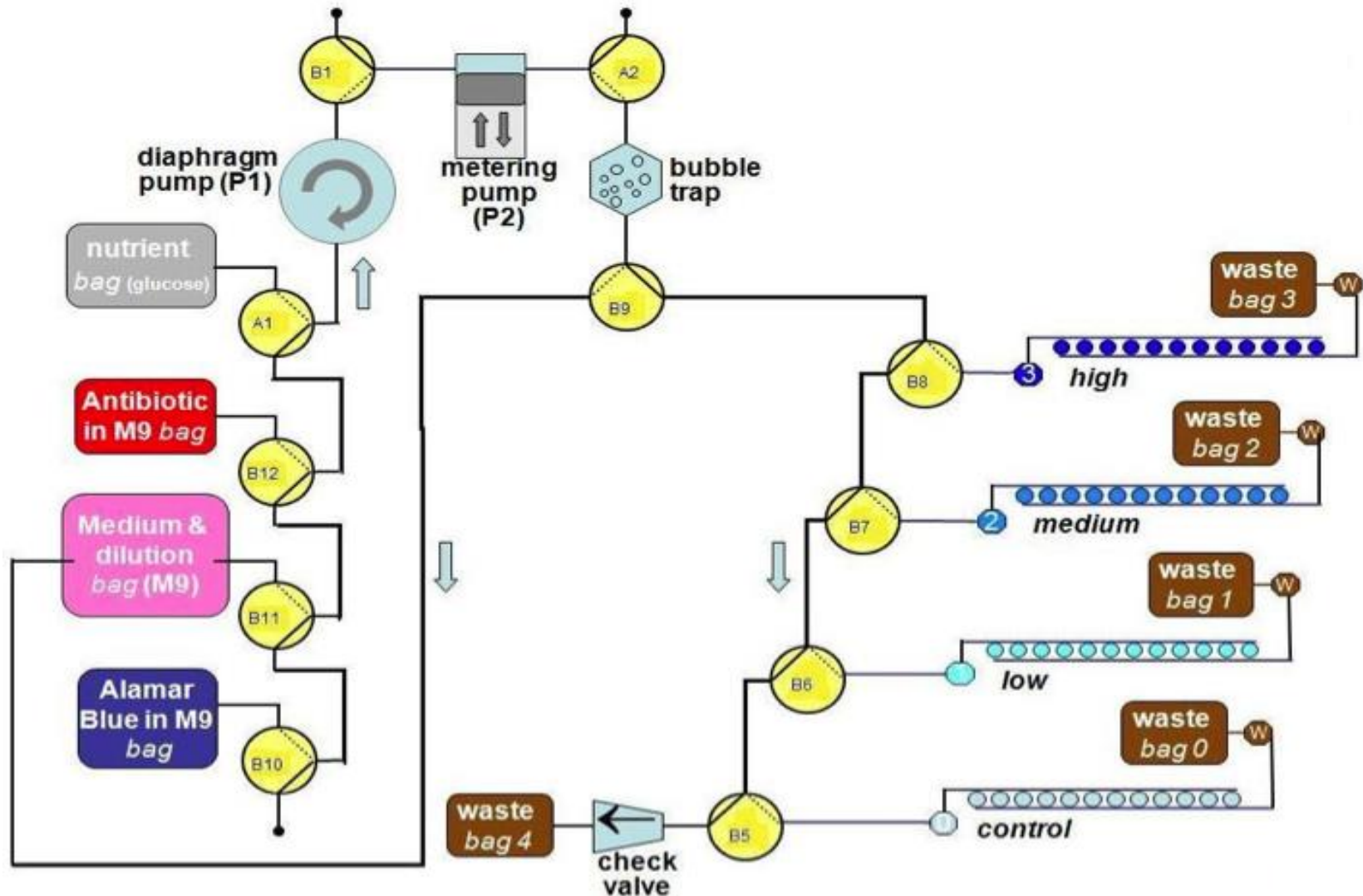



National Aeronautics and
Space Administration



EcAMSat Spacecraft Flight Build





National Aeronautics and
Space Administration



SYSTEM OVERVIEW

Mechanical Layout

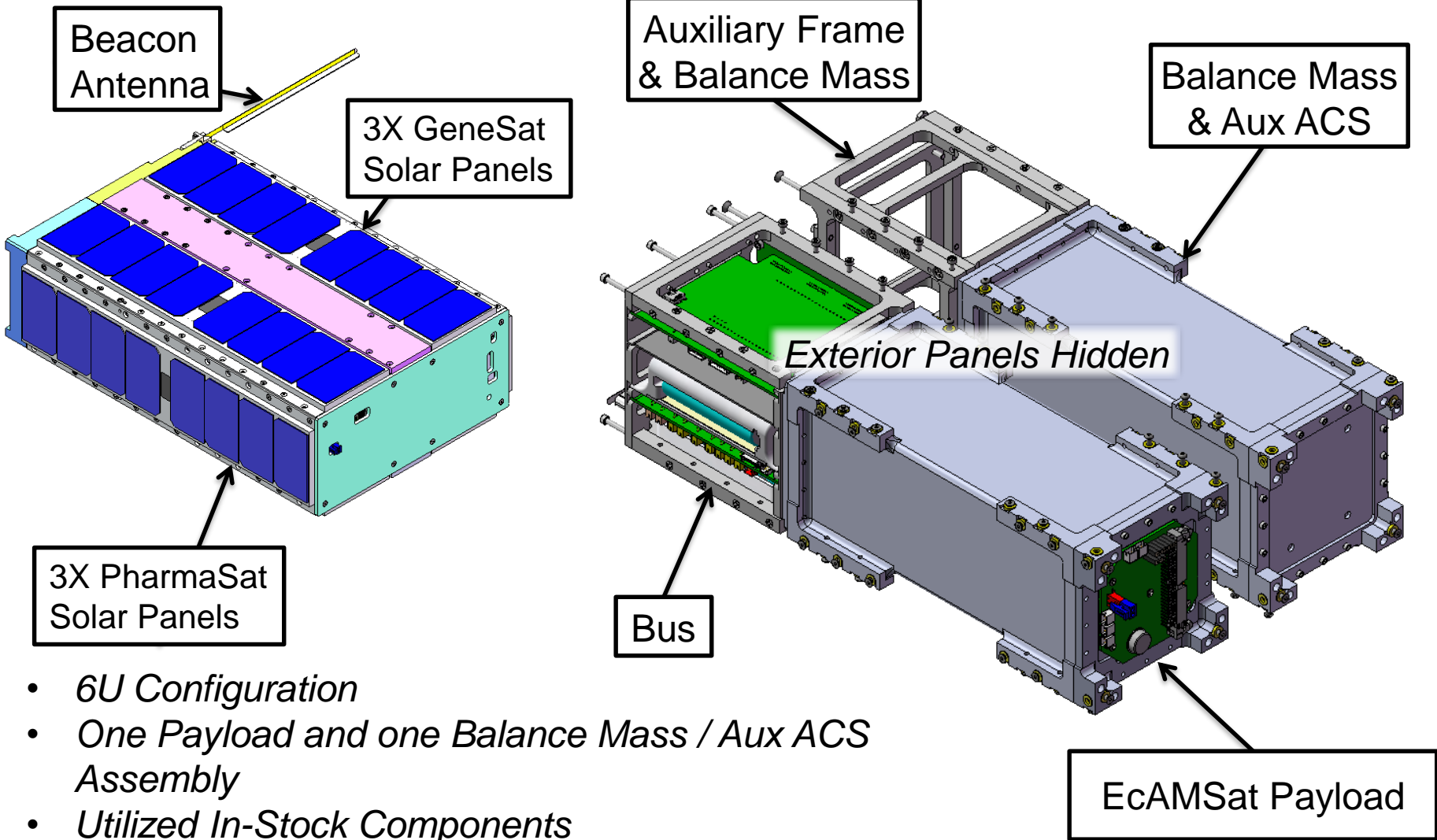

- *6U Configuration*
- *One Payload and one Balance Mass / Aux ACS Assembly*
- *Utilized In-Stock Components*
- *Combination of GeneSat and PharmaSat Solar Panels*



Electrical & Thermal Modifications

- **NanoSat 1.0 Bus modified to support additional solar panels & payloads**
 - Solar Panel area increased to accommodate higher payload temperature set point
 - Payload modifications made when EcAMSat branched into its own mission
- **Thermal system rework during switch from low-inclination (ISS) orbit to SSO**
 - Copper tape was added to Alodine surfaces to increase spacecraft steady-state temperature
 - Added to Auxiliary closeout panel, solar-panel splines & payload closeout panel
 - Dropped predicted average heater duty cycle from 90% to 60%
 - Analysis Data Flow
 - Orbital Dynamics - 6DOF De-tumble (MATLAB)
 - STK Solar Angle Vectors
 - Thermal Desktop Modeling
 - MATLAB power simulation

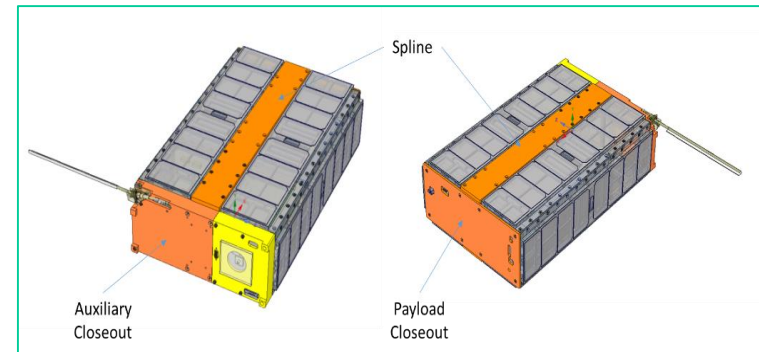

Orange indicates the addition of copper surfaces



National Aeronautics and
Space Administration



LAUNCH & DEPLOYMENT



National Aeronautics and
Space Administration



Launch Vehicle Opportunity Summary

- **SpaceX FormoSat-5**
 - Launch vehicle experienced 6 schedule slips
 - Final schedule slip resulted in all secondary payloads demanifesting
- **Orbital OA-8E**
 - Manifest to flight occurred in unprecedented <6 month timeframe for this class of biological satellite
 - Modifications made to spacecraft for ISS safety purposes (changed out clock batteries to approved chemistry)
 - PSRP process was conducted with a expedited schedule



Launch & Deployment

- **EcAMSat was deployed via the NanoRacks Doublewide Deployer (NRDD) with rail modifications.**
 - Existing “tab-rail” 6U deployer modified to support NASA 6U standard.
 - NRDD configuration did not exist 4 months prior to launch
 - Rapid build, fit checks and environmental testing was conducted on a flight unit.
- **EcAMSat was deployed via the NanoRacks Doublewide Deployer (NRDD) with rail modifications.**



NRDD in Soft Stowage Bag



NRDD

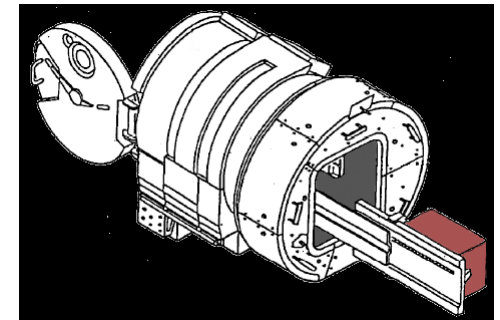

JEM Airlock Slide Table



National Aeronautics and
Space Administration



Orbital OA-8E ISS Resupply Launch





National Aeronautics and
Space Administration

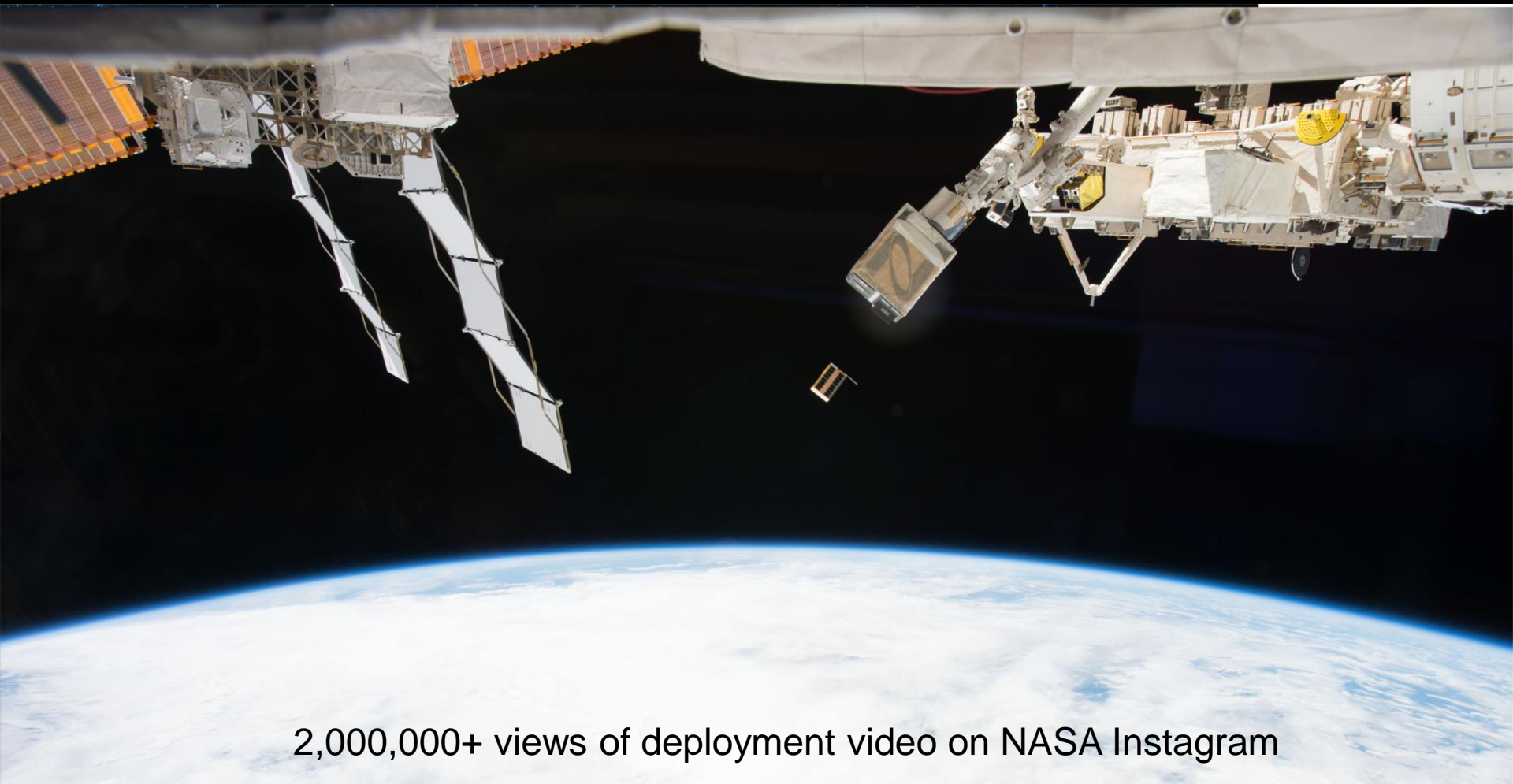

2,000,000+ views of deployment video on NASA Instagram



National Aeronautics and
Space Administration



ECAMSAT FLIGHT



Mission Concept of Operations

Nominal 252.5 hours between deployment and end of experiment

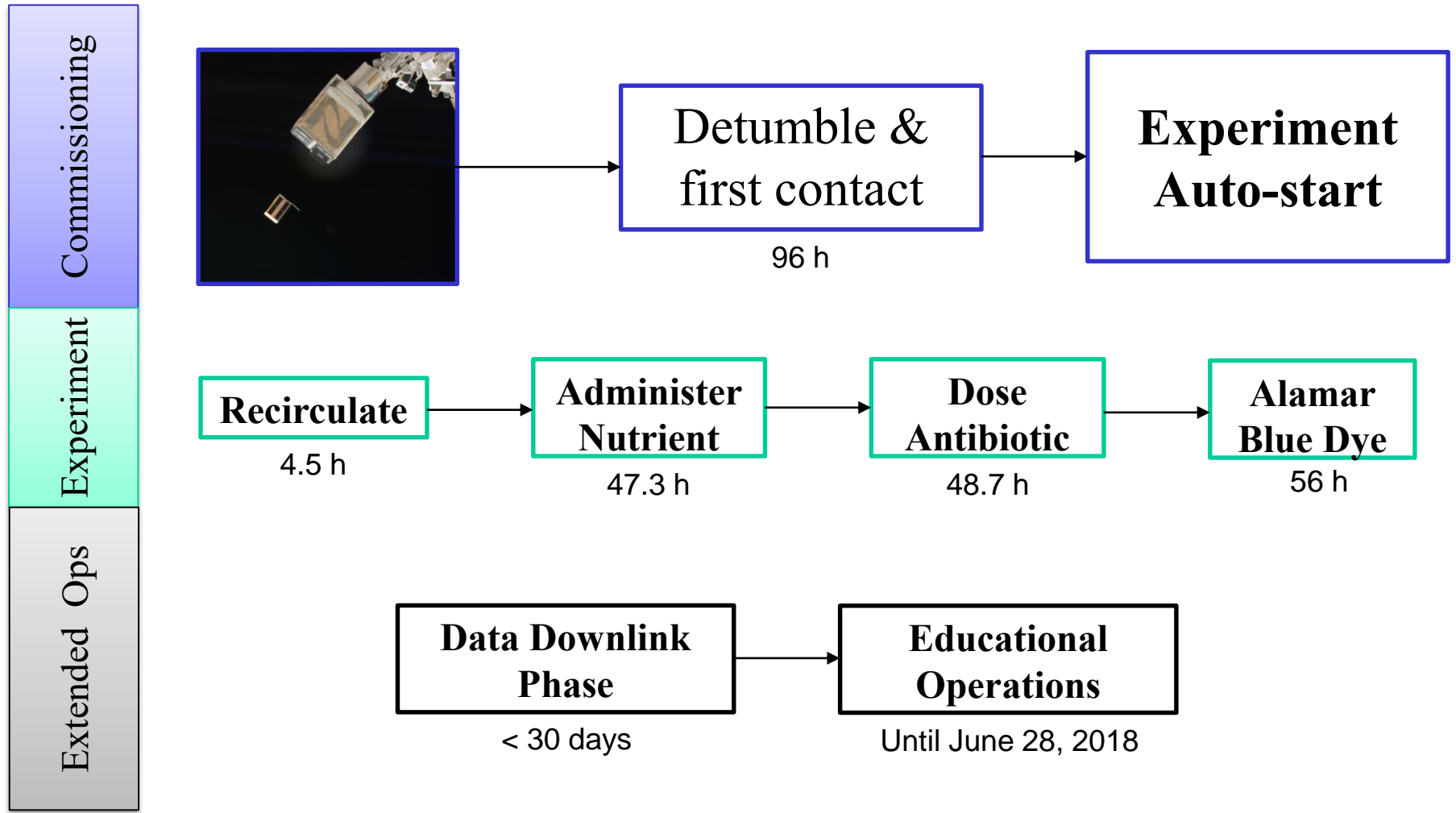



National Aeronautics and
Space Administration



Actual Mission Timeline

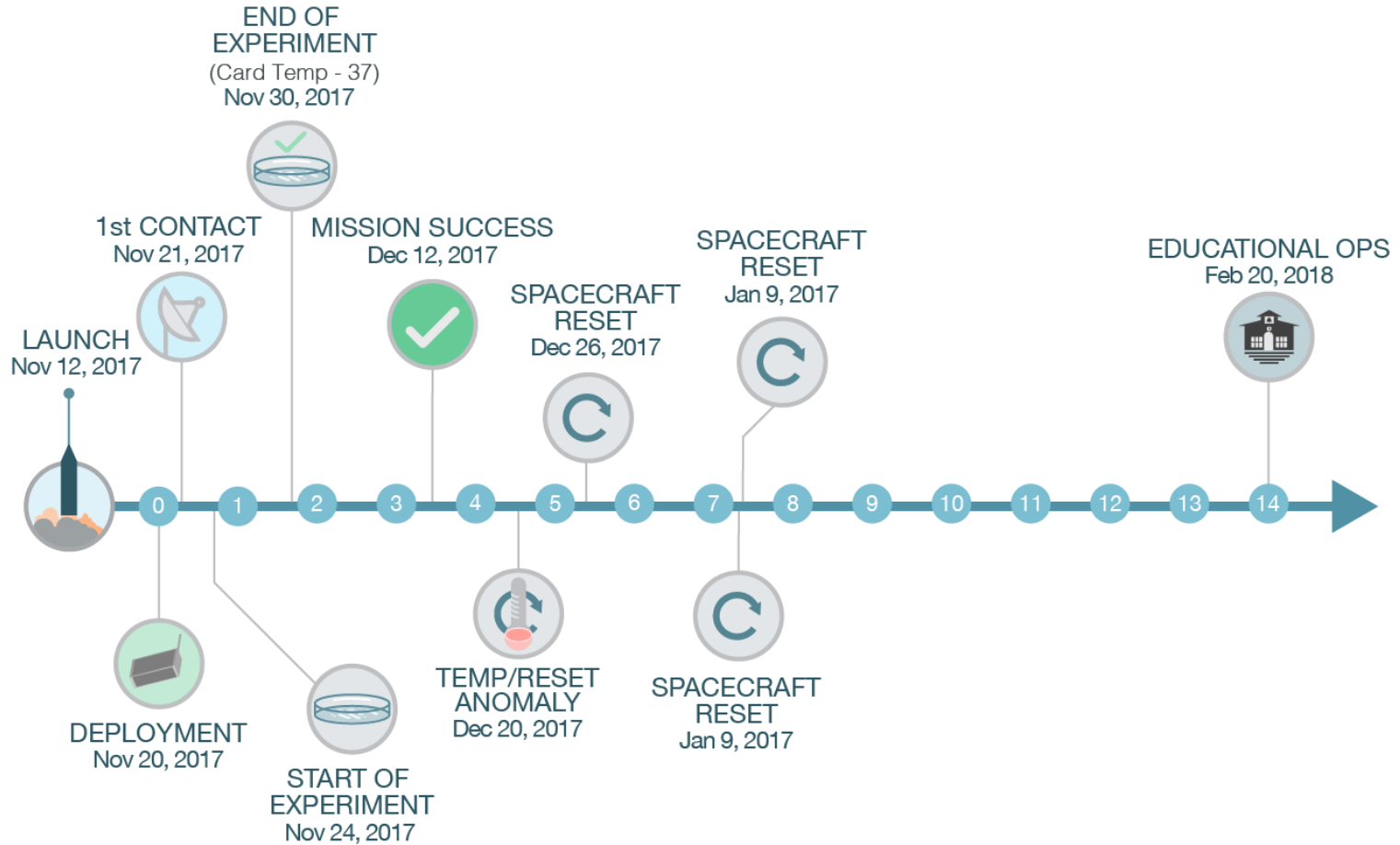



National Aeronautics and
Space Administration



PRELIMINARY FLIGHT RESULTS

Power Consumption

Battery Voltage

EcAMSat Flight Battery Voltage

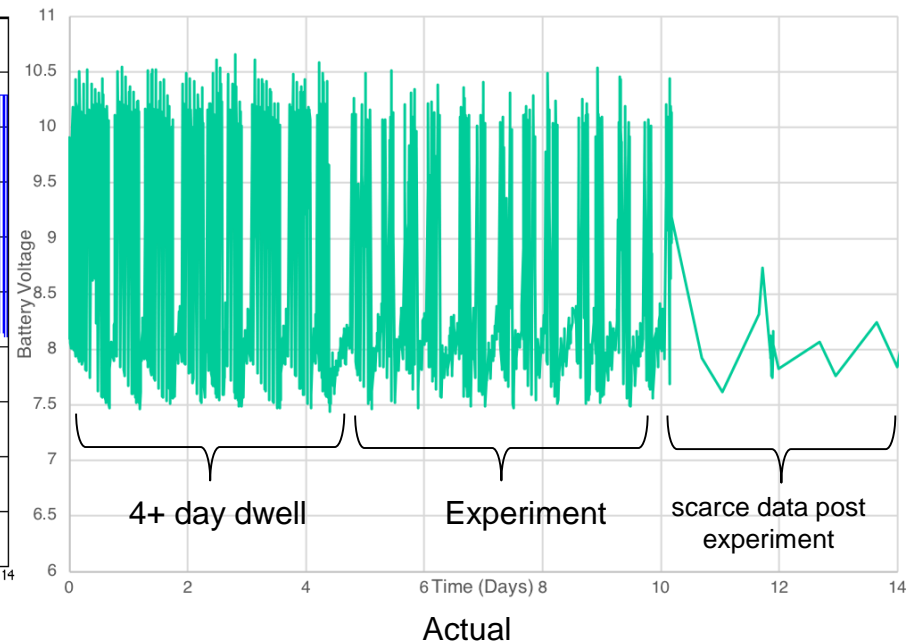
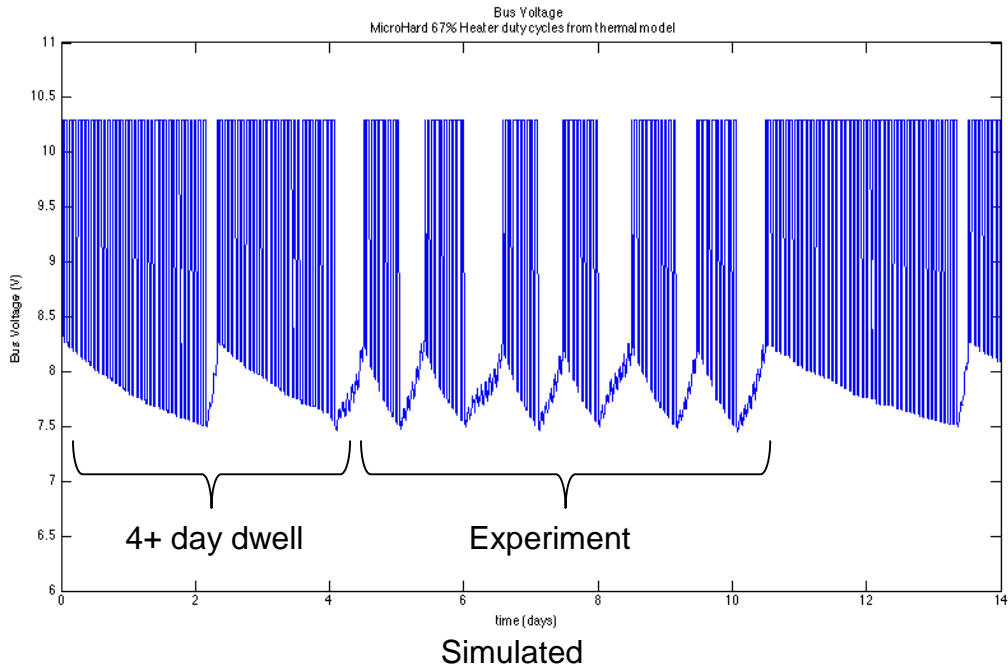

Communications Performance

- **NTIA licensed COTS radios on ISM and Amateur frequencies**

S-Band (MHX-2420)

- **978 KB data downloaded**
 - Bus Health Data – 274 KB
 - Payload Data – 509 KB
 - Log File – 76 KB
- **10,373 commands sent with a 23% response rate**
- **Success criteria exceeded by 300%**

UHF Beacon (Stensat)

- **Education & Public Outreach**
 - 437.100 MHz AX.25 packets
- **39 Ham Radio operators from 14 different countries**
- **8,848 beacon packets submitted**



National Aeronautics and
Space Administration



EPO - Beacon Submissions

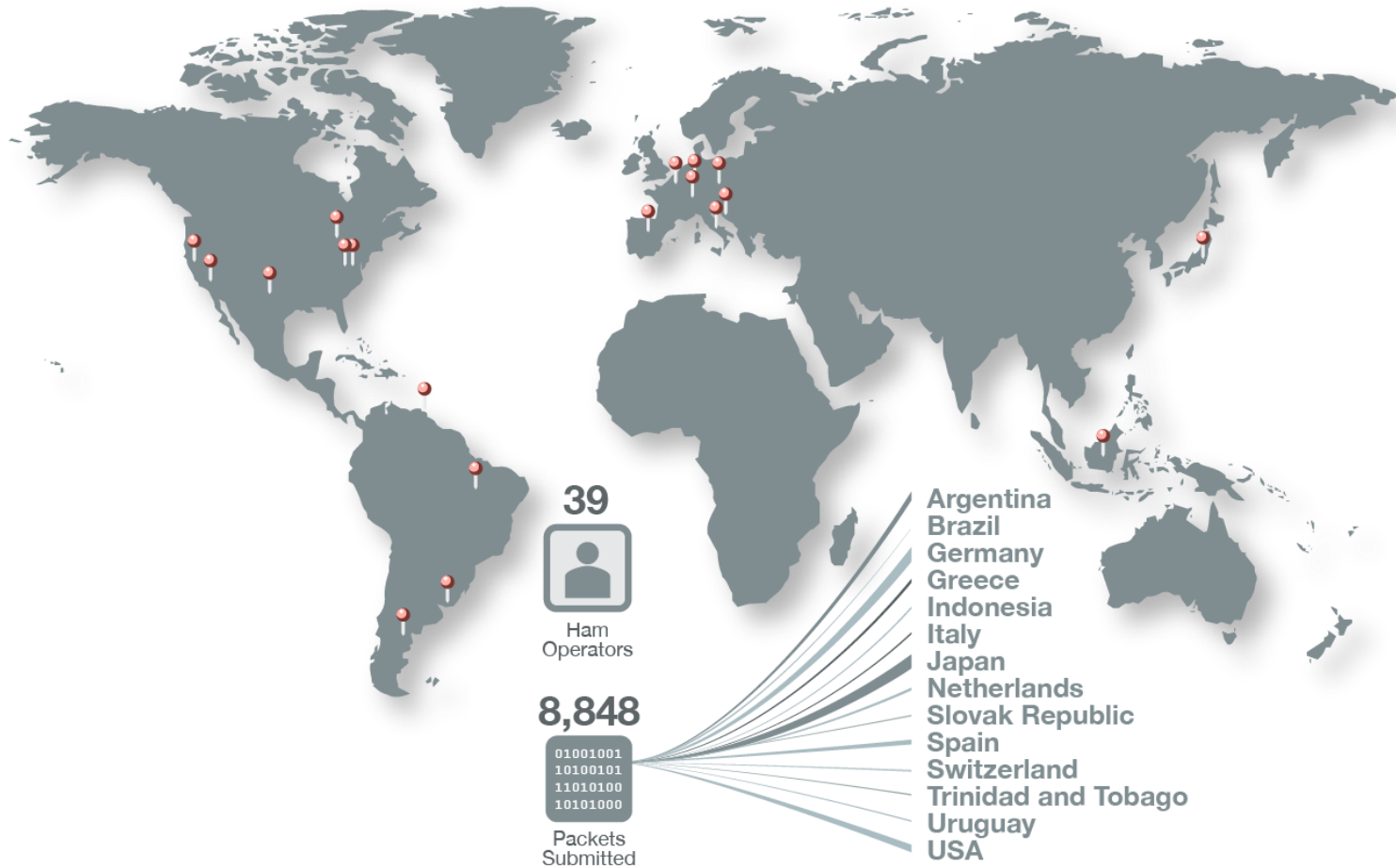

Scientific Data

- Received all required scientific data pages
- Downloaded additional data to exceed mission data collection requirements

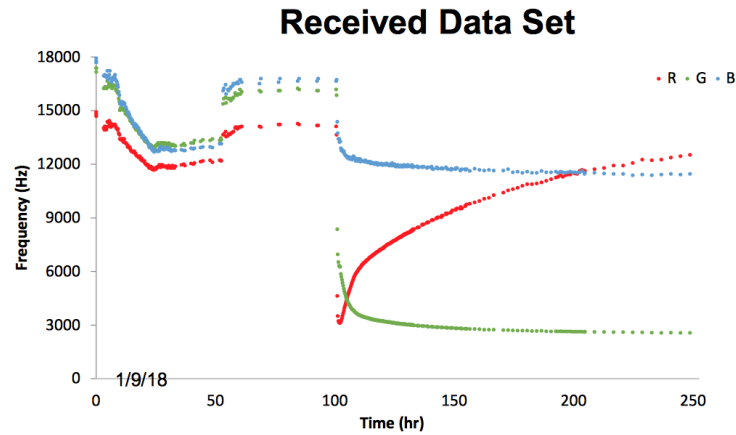
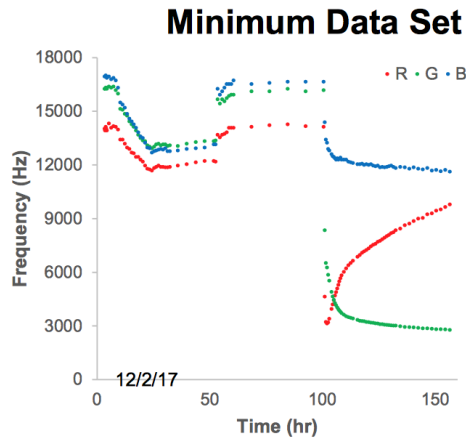

Data processing:

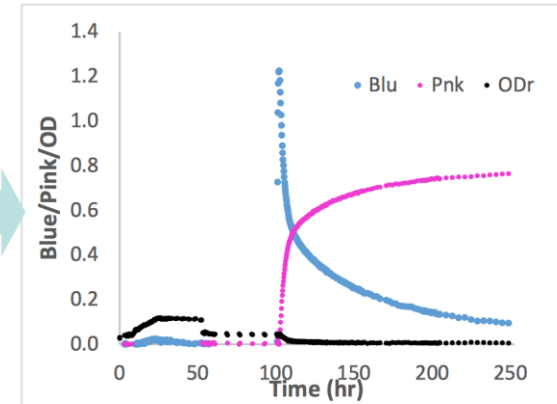
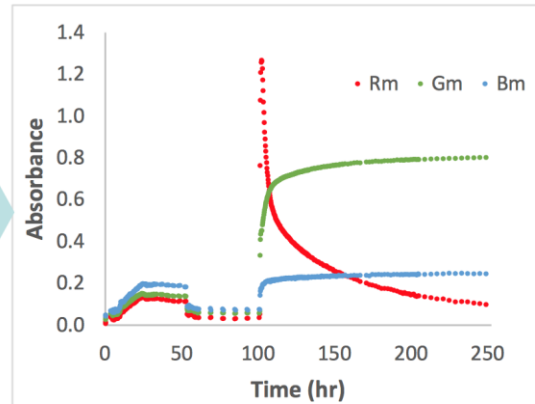
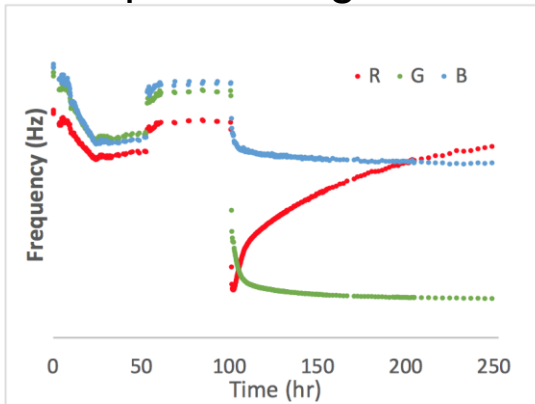



National Aeronautics and
Space Administration



References

<https://digitalcommons.usu.edu/cgi/viewcontent.cgi?article=1633&context=smallsat>

EcAMSat Mission Outbrief

EcAMSat Pre-Storage Review 2015