

NASA Low Power Stirling Converter for Small Landers, Probes, and Rovers Operating in Darkness

AIAA Propulsion and Energy (P&E) Forum and Exposition, International Energy Conversion and Engineering Conference (IECEC)

July 9-13, 2018, Cincinnati, OH

Session: ECD-02

Authors: Scott Wilson¹, Nick Schifer¹, Steve Geng¹, Terry Reid¹, Barry Penswick², Michael Casciani³

1. NASA Glenn Research Center, 2. Penswick Consulting, 3. Vantage Partners, LLC

Why Low Power RPS?

Small nuclear power systems that would provide electricity to probes, landers, rovers, or communication repeaters for space missions

- Operate in vacuum or on planetary surface (ie. Moon, Mars, more...)
- Use conversion technology to convert heat to electricity for powering spacecraft sensors and communications
 - Fractional GPHS (General Purpose Heat Source) offers around 60 watts of thermal input
 - LWRHU (Light Weight Radioisotope Heater Unit, often called RHU) offers around 1 watt of thermal input for each unit and multiple units could be used

Development Goals

- Sufficient power for spacecraft functions
- Long-life and low degradation to ensure power at EOM
- Robust to critical environments (vibration, shock, constant acceleration, radiation)
- Thermal capability and high efficiency

Dynamic Power Conversion

- **12-16% overall system efficiency possible from 1 to 10 watts electrical power output**

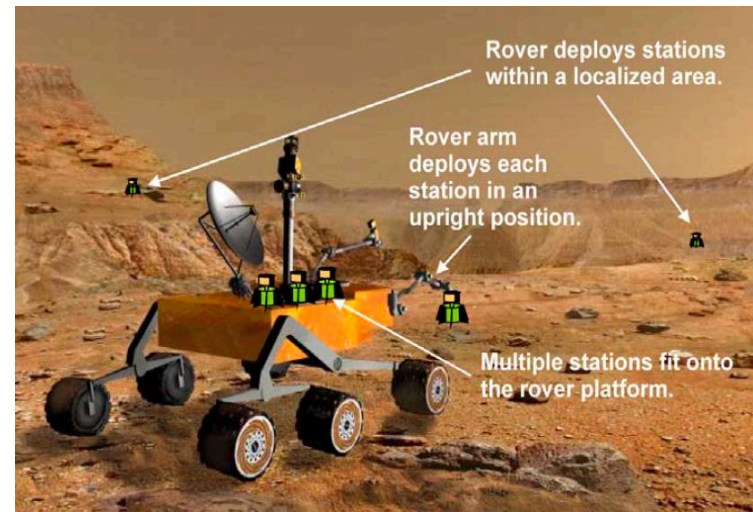

[Ref 1] Conceptualization of Seismic Monitoring Stations Being Deployed from Rover [JPL Pub 04-10, Sept-2004]

Technology Development at GRC

Low power dynamic RPS is being developed at GRC

- Main focus is to demonstrate practicality at the low power levels and to mature technology, subassemblies, and system interfaces.

Initial Demonstration (2018)

- Stirling convertor (proof of concept and performance mapping)
- Electrical controller (motor testing and receiving power from alternator)
- Multi-layered metal foil insulation (thermal simulator only)

Higher Fidelity (2019)

- Vacuum testing
- Characterization under vibration environment
- Robustness assessments
- Finalize requirements

System Testing (2020)

- Prototype testing of electrically heated system in vacuum

Low Power Dynamic RPS Concept

Design Goals

- Long life design (no wear mechanisms)
- 3 kg system mass
- Envelope of 11 cm diameter X 32 cm length
- Performance
 - Heat from multiple LWRHU
 - At least 1 We power output
 - At least 12% system efficiency
 - Maximum of 400 °C acceptor temperature
 - Maximum of 50 °C rejection temperature
- Robustness
 - Overstroke collision tolerant (limited time)
 - Operates in vacuum or atmosphere
 - Launch vibration
 - Constant accelerations
 - Shock
- Compliance
 - Minimize exported force
 - EMI

Low Power Dynamic RPS Concept

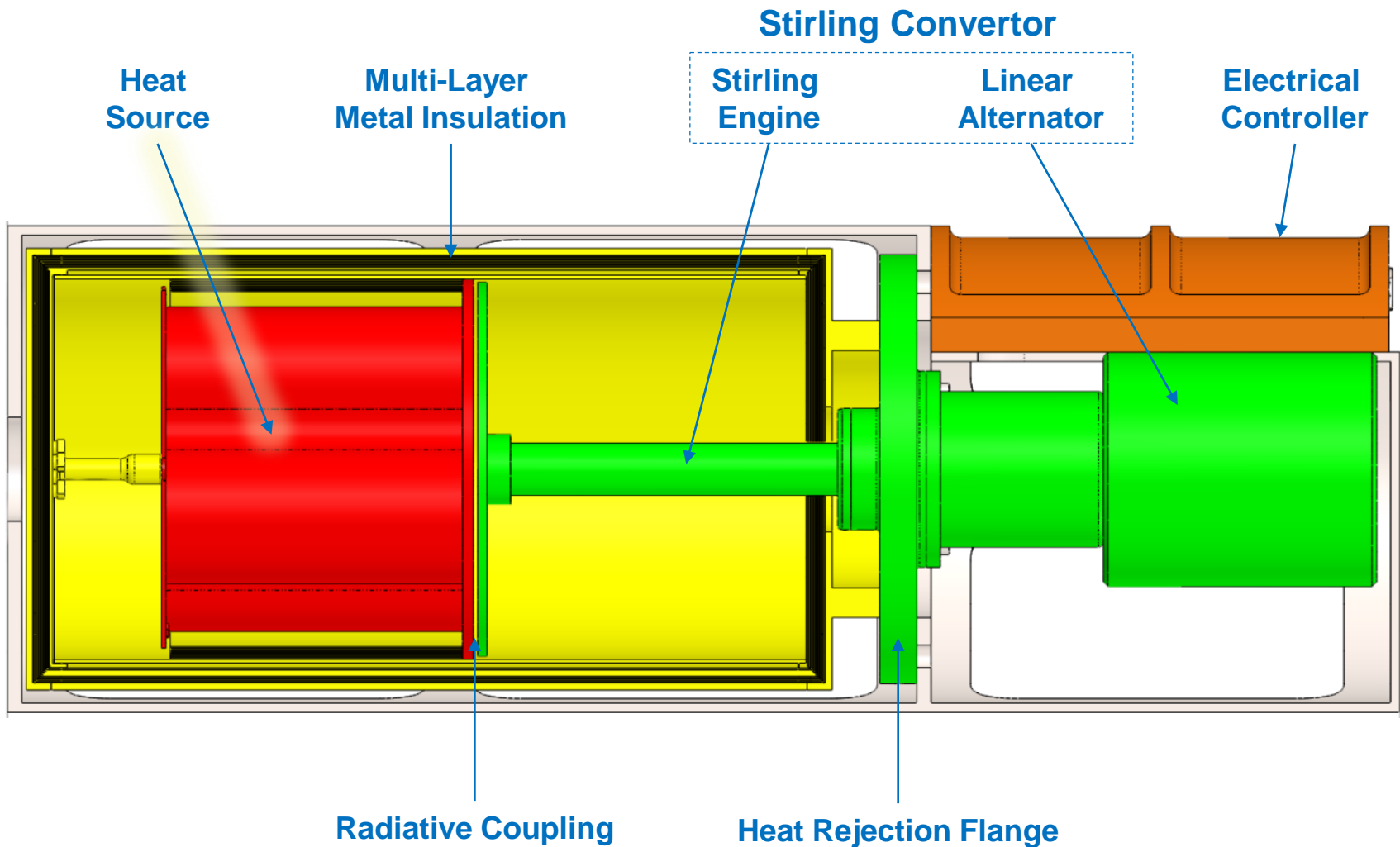

Heat Source

Light Weight Radioisotope Heater Unit (LWRHU)

- Used for decades to provide heat for spacecraft electronics
- Aeroshell designed to survive reentry into Earth's atmosphere
- Diameter: 1.0 inch, Length: 1.3 inch (1.1 watts of heat at fueling)

All GRC testing will use electric heaters to simulate LWRHUs

- Designed to provide similar thermal gradients compared to LWRHU
- One cartridge heater simulates two LWRHUs, four cartridge heaters needed to approximate 8 RHUs.

LWRHU Assembly



Welded wire bus

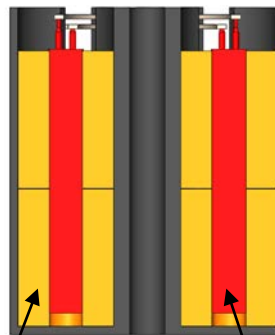

LWRHU volume
(orange)

Cartridge heater volume
(red)

Graphite block design



Insulation - Design

Objectives

- Due to low thermal input, high performing insulation is critical to minimize losses
- Peregrine Falcon Corp. under contract for Multi-Layered Metal Insulation (MLMI)
- High performance required (~ 0.001 W/m-K effective thermal conductivity)
- Insulation design complete, fabrication is underway

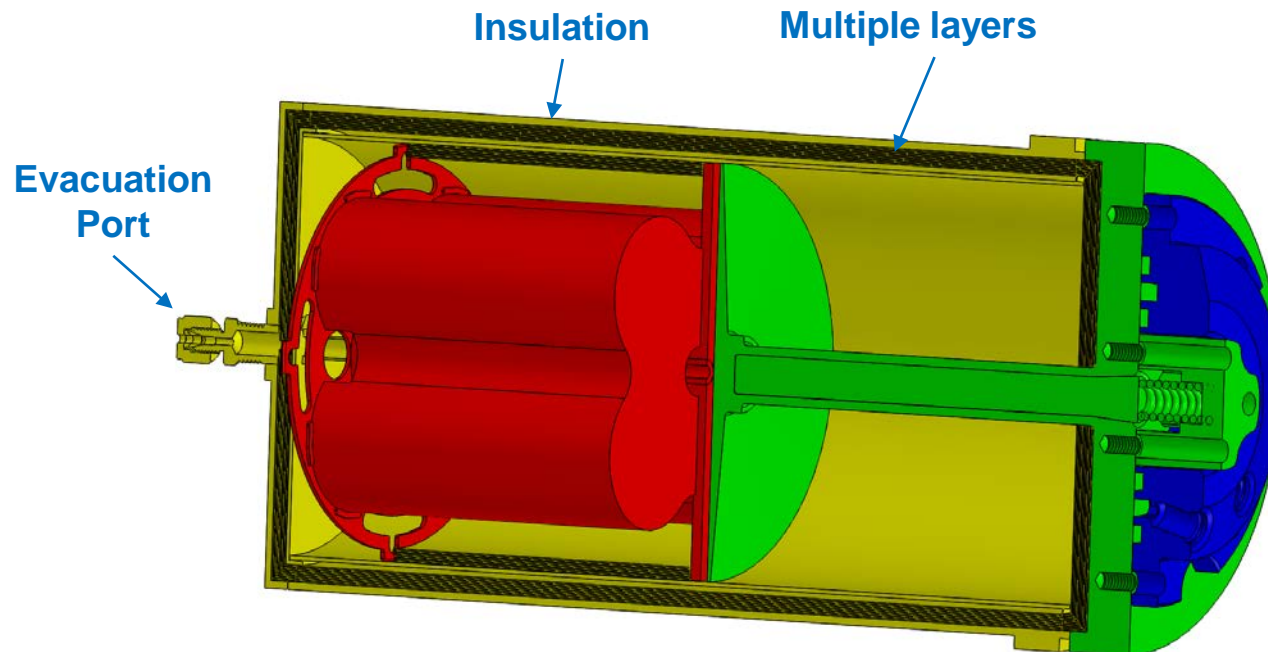

Insulation – Functional Testing

Thermal simulator used to perform functional testing of the insulation package

- 8 watts of thermal input, around 7 watts conducted through Stirling simulator
- Anticipate up to 50 °C temperature drop from heat source to the 350 °C Stirling hot end, across the radiative coupled interfaces
- Insulation package is evacuated to enable low thermal losses
- Prototype is non-hermetic to allow disassembly

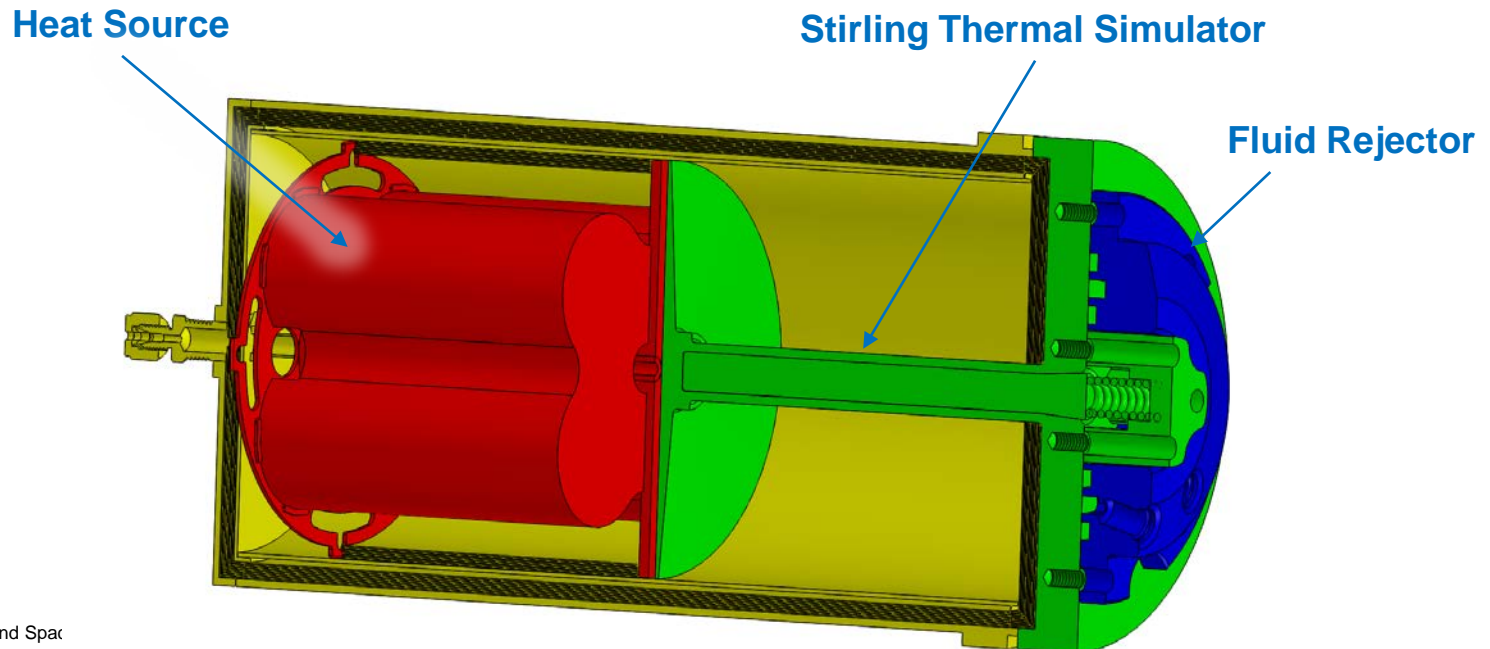

Stirling Converter

Proof of Concept - Fabrication

- Fabrication of converter is ongoing, assembly expected next month
- Split-Stirling, gas duct between engine and alternator compression space
- Gap regenerator – no porous matrix
- Flexure bearings for piston and displacer
- Laboratory design did not minimize mass
- Simulating heat from 8x RHUs using electric heater, 350 °C hot end temp
- Fluid loop heat rejection, 50 °C cold end
- 100 Hz, 110 psi helium, 4.5 mm X_p , 2mm X_d

Instrumentation

- Hall effect sensors (2x)
- Dynamic CS pressure transducer (1x)
- Hot and cold end temperatures (8x)
- Electrical heat input, alternator output

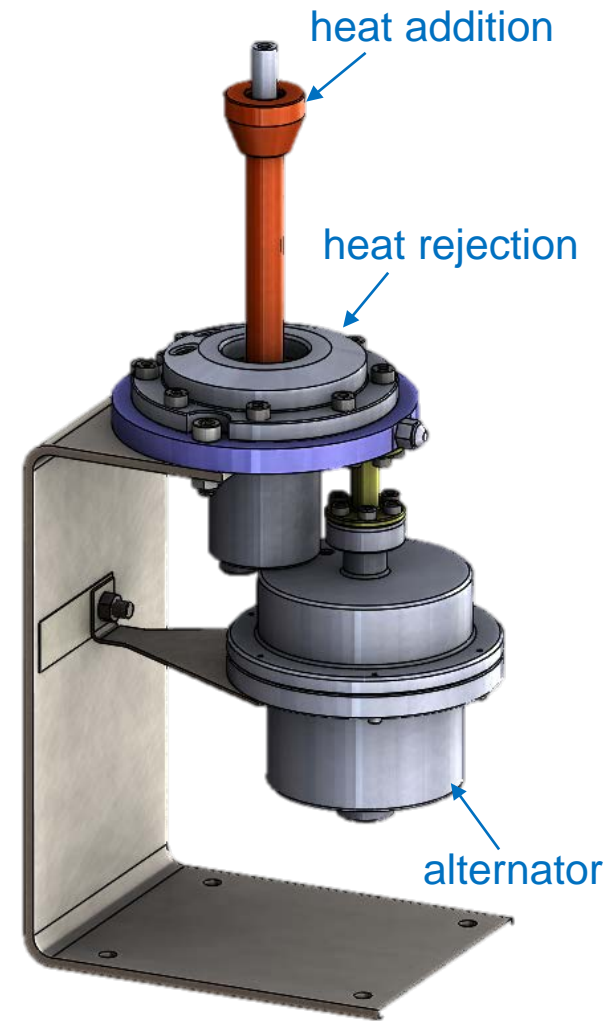

Test Setup
(insulation not shown)

Component Testing – Flexures

- Flexures used to provide axial springing & radial stiffness for piston and displacer

Endurance Limit Testing

- Flexure bearings underwent endurance testing to validate design models by intentionally failing specimens.
- Displacer flexures demonstrated up to 1.7x nominal amplitude for 700+ million cycles (100 Hz) without fracture. Amplitude exceeds hard stops.
- Piston flexures demonstrated up to 1.2x nominal amplitude for 500+ million cycles (100 Hz) without fracture. Amplitude exceeds hard stops.



Flexure Bearing Test Setup

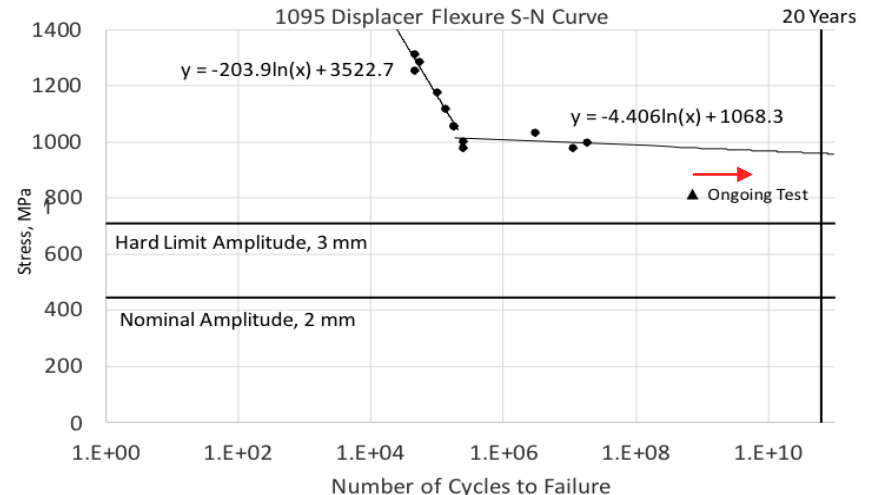

Stress vs. # of Cycles Data

Component Testing - Alternator

Initial moving coil alternator (100 Hz)

GRC Design

- Low Inductance, dual flux path
 - 5 mm mover amplitude
 - 4 coils, 80-turn per coil
- Analysis Results
 - $P = 1.26 \text{ W}$, Avg Inductance = 0.485 mH
- **Near perfect power factor**
- High THD = smoothing (less power)
- Cogging force needs characterization
- **Pathfinding assembly processes**

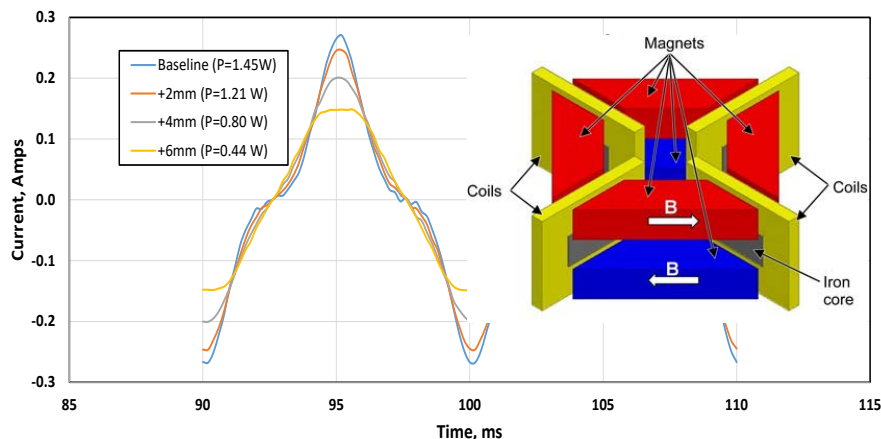

Testing to Date

- Motored alternator to 4.26 mm @ 103.9 Hz
- Demonstrated conduction across flexures
- Demonstrated non-contact operation

Next Steps

- Tune to meet desired frequency
- Achieve full 5.0 mm amplitude
- Characterize as an alternator

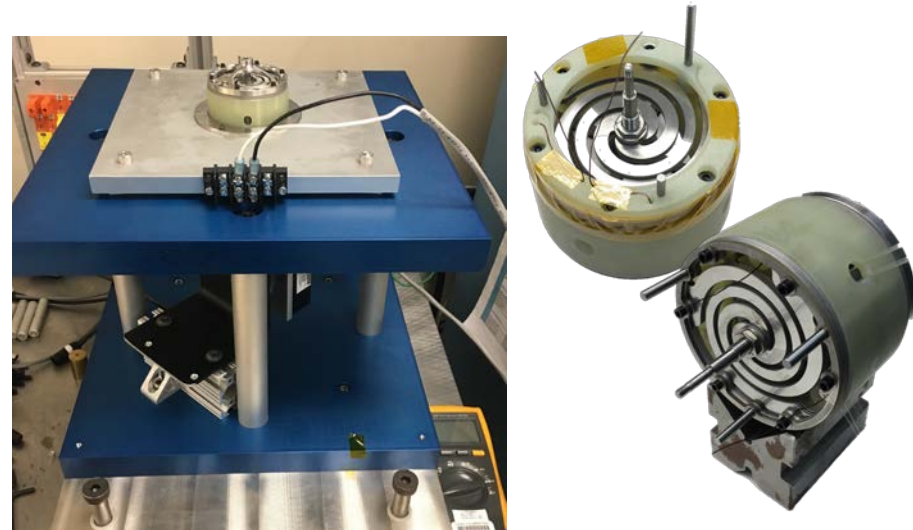

Additive Manufacturing (AM)

- Advantages: 1) reduce part count, 2) replace traditional joints (brazed, welded, etc.), and 3) more efficient & simpler production
- Recent focus on displacer assemblies with embedded radiation baffles
- Specimens used for pressure testing, heat treatment, finish machining trials, emissivity trials, and revised printing methods to improve geometry
- Results:
 - Printed 250 micron thick internal baffles and 300 micron external wall thickness using Inconel 718 metal powder

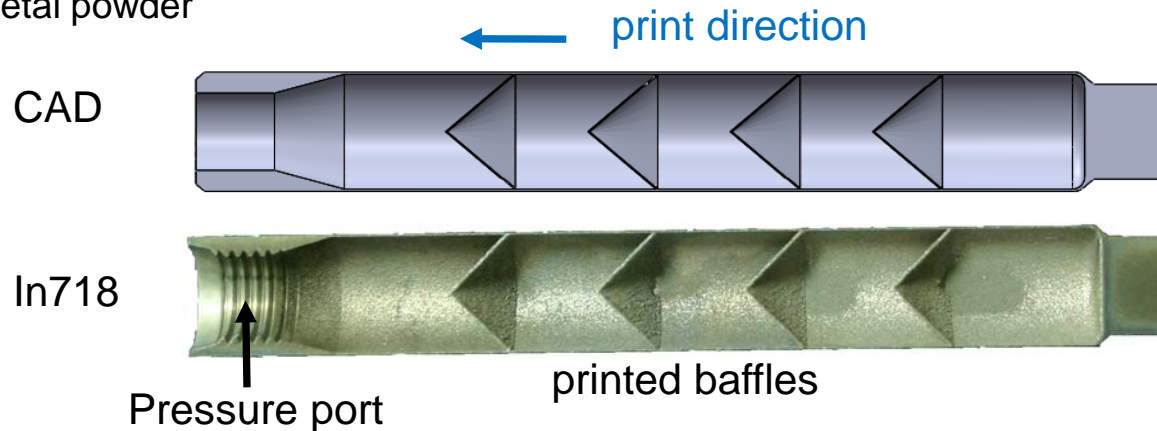

- Ground OD. Able to achieve 80 micron wall thickness, and still hold pressure.



Modeling

3D CFD vs. 1D Sage

- Two codes were used to predict engine performance, modeled domain was truncated at the piston face and displacer rod (no seals or bounce spaces)

Key differences between codes

- Sage connects fixed temperatures directly to ends of the displacer, which artificially elevates displacer temps and associated axial parasitic heat transfer losses, while Fluent model resolves those in thermal and fluid flow fields
- Sage assumes no motion by the displacer when resolving just the heat transfer while Fluent resolves temperature gradients and heat transfer by moving components and deforming gas volume meshes.

Codes agree fairly well

- The PV power output agree within 8%

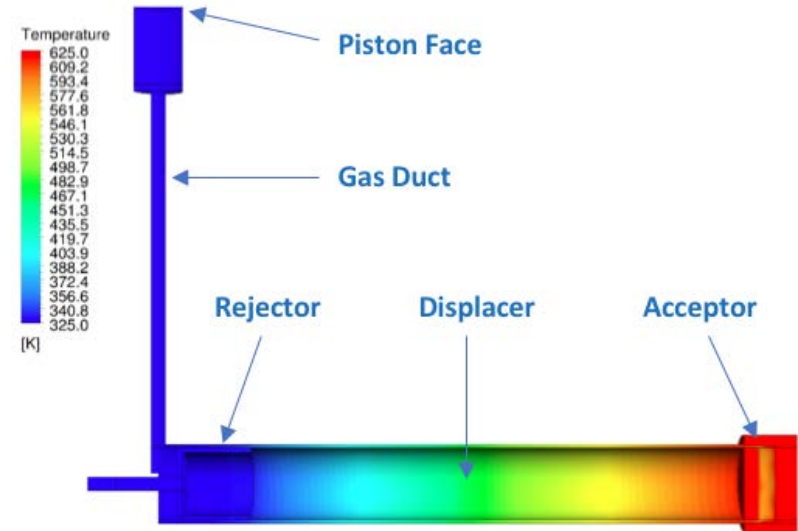

Energy Balances from the Mini Stirling Model			
Model Type		SAGE	FLUENT
Operating Boundary Condition		Fixed Temp Surface	Fixed Temp Volume
Heater Acceptor Temperature (K)		625	625
Heat Rejector Temperature (K)		325	325
Item	Description	Baseline	Baseline
1	Heat Input by Acc (Q_{IN})	5.784	5.941
2	Expansion Space	4.514	5.247
3	Enter Hot Heater Head Cylinder	0.635	0.694
4	Enter Hot Regen Gas	0.318	0.926
5	Enter Hot Displ Cylinder	0.635	0.329
6	Exit Cold Heater Head Cylinder	0.271	0.589
7	Exit Cold Regen Gas	1.046	1.069
8	Exit Cold Displ Cylinder	0.271	0.290
9	Rejection (Q_{OUT-1})	4.266	4.306
9a	Rejector	3.310	3.282
9b	CsD	0.781	0.861
9c	Duct	0.383	0.316
9d	Displacer Flex Rod	0.000	0.040
9e	Piston Face	0.016	0.439
10	Energy Balance ($Q_{IN} - Q_{OUT}$)	1.518	1.635

Controller

Initial Breadboard Testing Successful

- Demonstrated linear AC regulator controller using a MOSFET H-bridge with analog circuit to control FETs for AC to DC rectification and load control
- Constant power load monitoring allows for load control and shunting of unused power

Analysis Results

- LTspice model contains a linear alternator, H-bridge rectifier, constant power circuit, and waveform smoothing circuit for power factor and Total Harmonic Distortion correction
- Results: 0.99 PF (THD 2%), 85% efficiency (210 mW loss), 1.1 We output

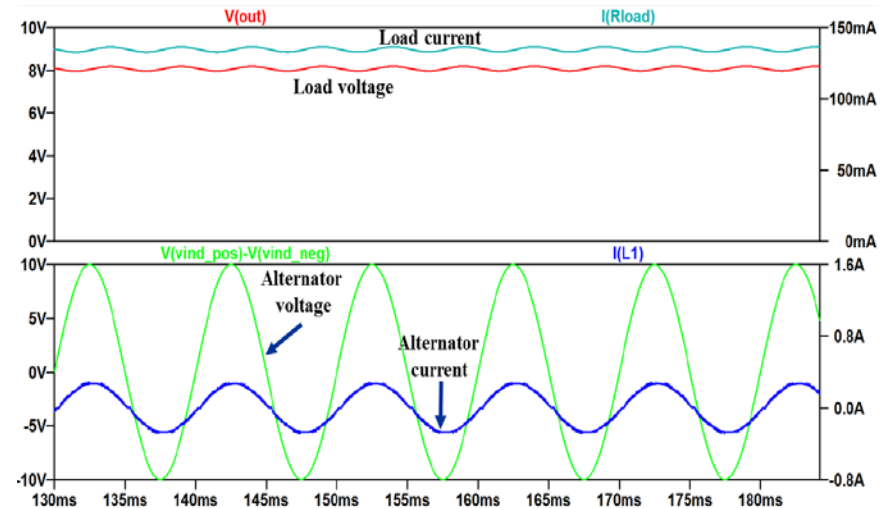

Summary

- Small RPS are being considered for small spacecraft missions
 - Enables long-life power for use in darkness
- 1-W Stirling RPS is in development at NASA GRC
- 2018 Development goals include:
 - Demonstration of convertor, controller, and high-performance insulation
 - Initiated scaling study up to 10 watts
- **Testing starts this summer!**



Special thanks to contributors

- Cheryl Bowman
- Daniel Goodell
- Malcolm Robbie
- Paul Schmitz
- Roy Tew

Thank you for attending