

BioSentinel/Mars: Interplanetary Space Radiation Biosensor Experiment in Martian Transit on Mars 2020

A.J. Ricco, R. Hanel, B. Lewis, and S. Bhattacharya
NASA Ames Research Center, Moffett Field, CA, USA

Despite significant progress understanding biological radiation effects via terrestrial studies, no terrestrial source duplicates space's unique radiation environment. Furthermore, no biological experiments have been conducted beyond low Earth orbit since Apollo. Understanding space's fundamental biological effects requires overcoming these limitations.

The BioSentinel 4U payload, under development for flight aboard Exploration Mission-1, measures biological responses to deep space radiation. Traveling to more than 1AU from Earth, BioSentinel/EM-1 will record DNA double-strand breaks (DSBs) repaired using a pathway common to humans and BioSentinel's bioengineered yeast model organism, responding to as few as one biologically repaired DSB.

The BioSentinel/Mars 4U instrument (6-8kg; 5-8W; 0.2-1MB/week) would include eighteen 16-well biosensor fluidic cards, activated biweekly during Mars 2020's cruise phase, to provide a dose-dependent rate of DSB/repair. The instrument, which includes solid-state sensors for total ionizing dose and linear-energy-transfer spectra, addresses MEPAG SKG-B3 by simultaneously measuring both spectra and biological effects of space radiation.

Biological measurements are rendered reliable by independent replicate experiments. The spatio-temporal uniformity of interplanetary galactic cosmic radiation makes BioSentinel/EM1 and BioSentinel/Mars approximate replicates, except for any major differences in solar particle events. Results will be compared to Earth and ISS controls to characterize the radiation/reduced-gravity parameter space by its biological impact.

Notes on maturation: The concept will be fully mature for Mars 2020. Continuing development of BioSentinel under the Advanced Exploration Systems program is in progress and will bring this payload to deep spaceflight readiness, with a planned deep-space functional lifetime of ~ 18 months, by late 2017. This includes development, test, and integration of the biological, fluidic, optical, electrical, thermal, and mechanical subsystems, as well as physical radiation sensor/spectrometer components and flight software. To fly on Mars 2020, the BioSentinel instrument will require changes to some interface and flight software details in order to accommodate differences between BioSentinel's small-sat. deep-space bus and the Mars 2020 bus. The 4U payload/instrument would be otherwise essentially unchanged in its EM-1 and Mars 2020 implementations.



BioSentinel/Mars: Interplanetary Space Radiation BioSensor Experiment in Transit on Mars 2020

Tony Ricco – BioSentinel Payload Technologist
NASA Ames Research Center

11/21/14





BioSentinel/SLS EM-1 Project Objectives

- Advance Exploration System (AES) Program Office selected BioSentinel to fly on the Space Launch System (SLS) Exploration Mission (EM-1) as a secondary payload
 - Payload selected to help fill **HEOMD Strategic Knowledge Gaps in Radiation effects on Biology**
 - Development Schedule based on a December 2017 Launch
- Key BioSentinel Project Objectives
 - Develop a ***deep space nanosat*** capability
 - Develop a ***radiation biosensor*** useful for other missions
 - Define & validate **SLS secondary payload interfaces and accommodations** for a biological payload
- **BioSentinel Mars Objective**
 - BioSentinel Payload measures the Radiation effects on Biology over a 9-Month Earth to Mars Trip
 - Flies on Cruise stage using power and data resources
 - Mission ends on approach to Mars

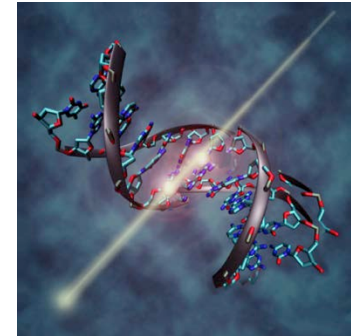



BioSentinel Relevance to SKGs

GOALS

- Life science studies beyond low Earth orbit (LEO) relevant to human exploration
- Use simple organisms to inform us of greatest risks to humans beyond LEO, so that appropriate protection can be developed & dangers can be mitigated
- Critical advances to autonomous life support technologies for small organisms

Filling Strategic Knowledge Gaps (SKGs)	
SKG documents	Gaps
Mars Precursor Strategic Analysis Group (P-SAG) SKGs, May 2012	II-D Effects of radiation and effectively low g on biology and physiology III-G Radiation shielding, specifically for subsystems
P-SAG & MEPAG (Mars Exploration Program Analysis Group)	B3-2, Crew Health and Performance: place detector in orbit to measure energy spectra during Solar Energetic Particle Events (SPEs)
SBAG SKGs, Nov 2012	III-B: Ionizing Radiation Environment at Small Body Surfaces
LEAG-SAT SKGs, March 2012	A4-4: Auto systems tech demo A4-6: Life support tech demo A4-7: Mechanisms tech demo B3-6: Radiation shielding B5-3: Microbial survival, Mars conditions

The 1st Biology Experiment beyond LEO since Apollo

The limits of life in space, as we know it, is 12.5 days on a lunar round trip or 1 year in LEO. As we send people further into space, we can use model organisms to understand the biological risks and how they can be addressed.

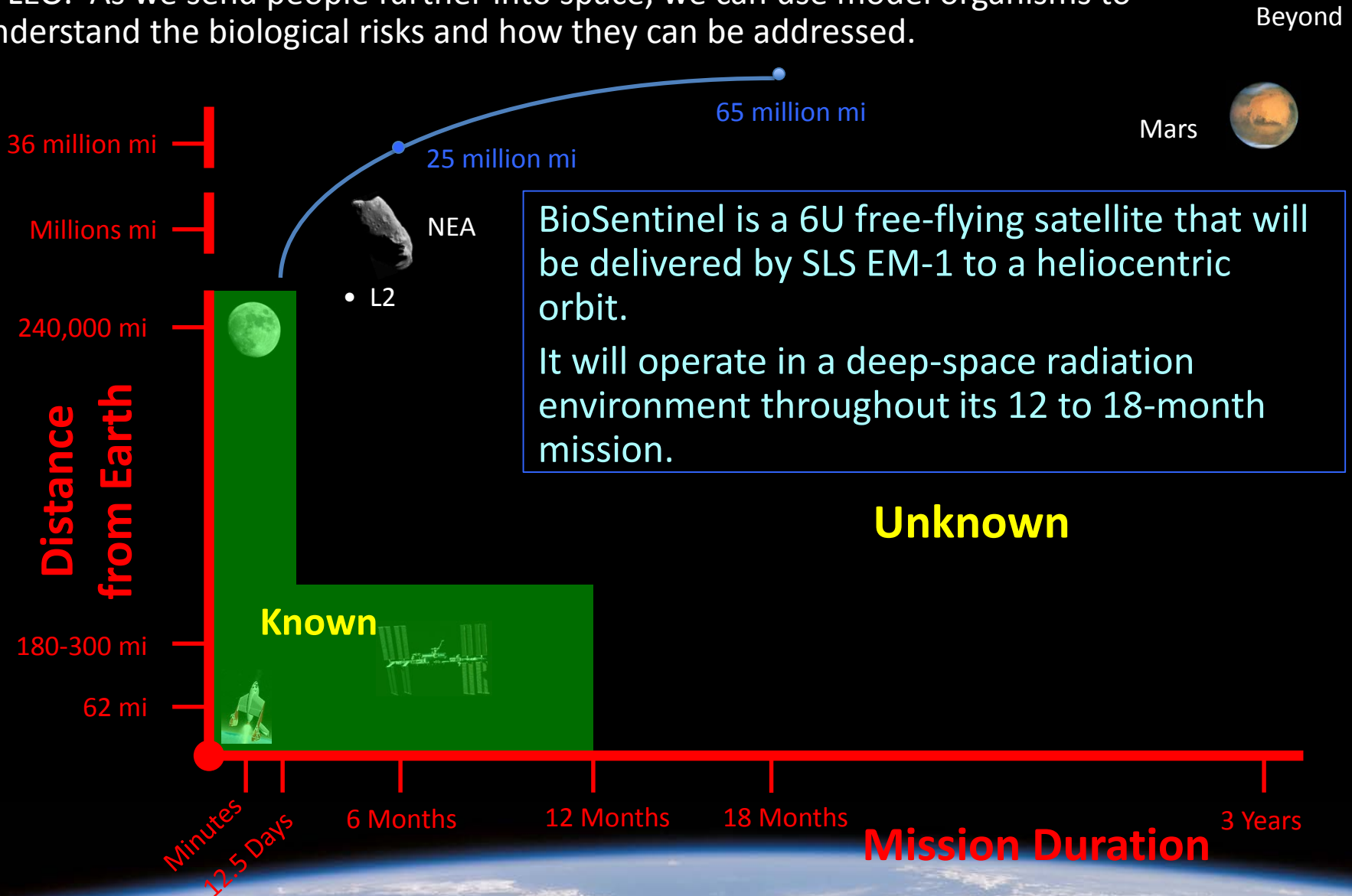



BioSentinel Science Concept

- **Quantify DNA damage from space radiation environment**
 - Space environment cannot be reproduced on earth
 - Omnidirectional, continuous, low flux with varying particle types
 - Health risk for humans spending long durations beyond LEO
 - Radiation flux can spike 1000x during a solar particle event (SPE)
- **Correlate biologic response with LET and TID data**
 - BioSensor payload uses engineered *S. cerevisiae* yeast
 - Measures rate of Double Strand Breaks (DSB) in DNA
 - Linear Energy Transfer (LET) spectrometer measures particle energy and count
 - Total Ionizing Dose (TID) dosimeter measures integrated deposited energy
- **Yeast assay: microfluidic arrays monitor DSB/repair**
 - Three strains of *S. cerevisiae*, two controls and engineered strain
 - Wet and activate multiple banks of microwells over mission lifetime
 - DSB and associated repair enable cell growth and division
 - Activate reserve wells in event of a Solar Particle Event (SPE)





BioSentinel Mars Instrument

- Use the BioSentinel Payload currently in development
 - 18 Fluidic Card BioSensor Payload; Each Card has 16 micro-fluidic wells
 - Volume: ~4U (10 cm x 20 cm x 20 cm)
 - Mass: 6-8 kg
 - Power: 5-8W
 - Data Volume: 0.2-1MB/week
 - Linear Energy Transfer (LET) Spectrometer
 - Total Ionizing Dose (TID) Dosimeter
- Attach to Mars 2020 Cruise Stage to provide power and relay data back to Earth
- Wet 1 card every 2 weeks over the 9 –month Cruise Phase
- **Graphics from Abe**



Initial-Draft Science Requirements

- **Investigate biological space radiation effects on model organisms**
 - Duration: 6 / 9 months = minimum / full success
 - Location: In transit to Mars, beyond shielding of Earth's magnetosphere
 - Measurement 1: Repair of DNA double strand breaks (DSBs)
 - Measurement 2: Long-term survival of a model organism
 - Measurement 3: Response to a solar particle event (SPE), if available
- **Monitor space radiation environment with physical rad'n. sensors**
 - Linear energy transfer (LET) characteristics
 - Total integrated ionizing dose (TID)
- **Correlate Mars transit results with other environments**
 - EM-1 secondaries heliocentric beyond-LEO orbit
 - Ground-based control at low radiation (terrestrial background)
 - Ground-based radiation exposure (BNL, LLUMC)
 - LEO studies (ISS)

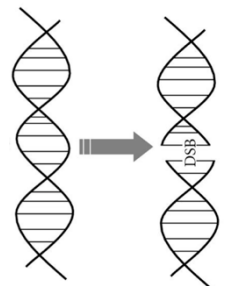
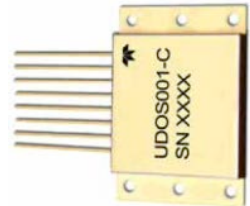



Biological Support & Measurement Systems

- support biology in stasis & growth
- enable & perform measurements
 - biological ***and*** physical radiation responses
 - 6 – 9 months
 - beyond-LEO environment: cosmic radiation including solar particle event if it occurs
- compatible with multiple platforms
 - free flyer (EM-1), Mars 2020, ISS, ground experiments
 - robust, standard data & power interfaces



Payload: Biological Support & Measurement Systems

Configuration:

~4U hermetic containment vessel

- 1 atm internal pressure, low RH
- Fluidics: 18 “sets” of 16 μ wells ea.
 - ❖ 2 sets activated ~ monthly
 - ❖ 1 – 2 sets on “SPE standby”
- organisms fly dry; rehydrate to activate
- **Pumps, Valves, Tubing, Media**
 - external to cards
 - low-permeability card, tubes, bags: keep the dried yeast dry





BioSentinel/Mars Instrument

Payload: Biology / Fluidic / Optical / Thermal Configuration

Cross-section: 1 of (16 x 18) = 288 microwells

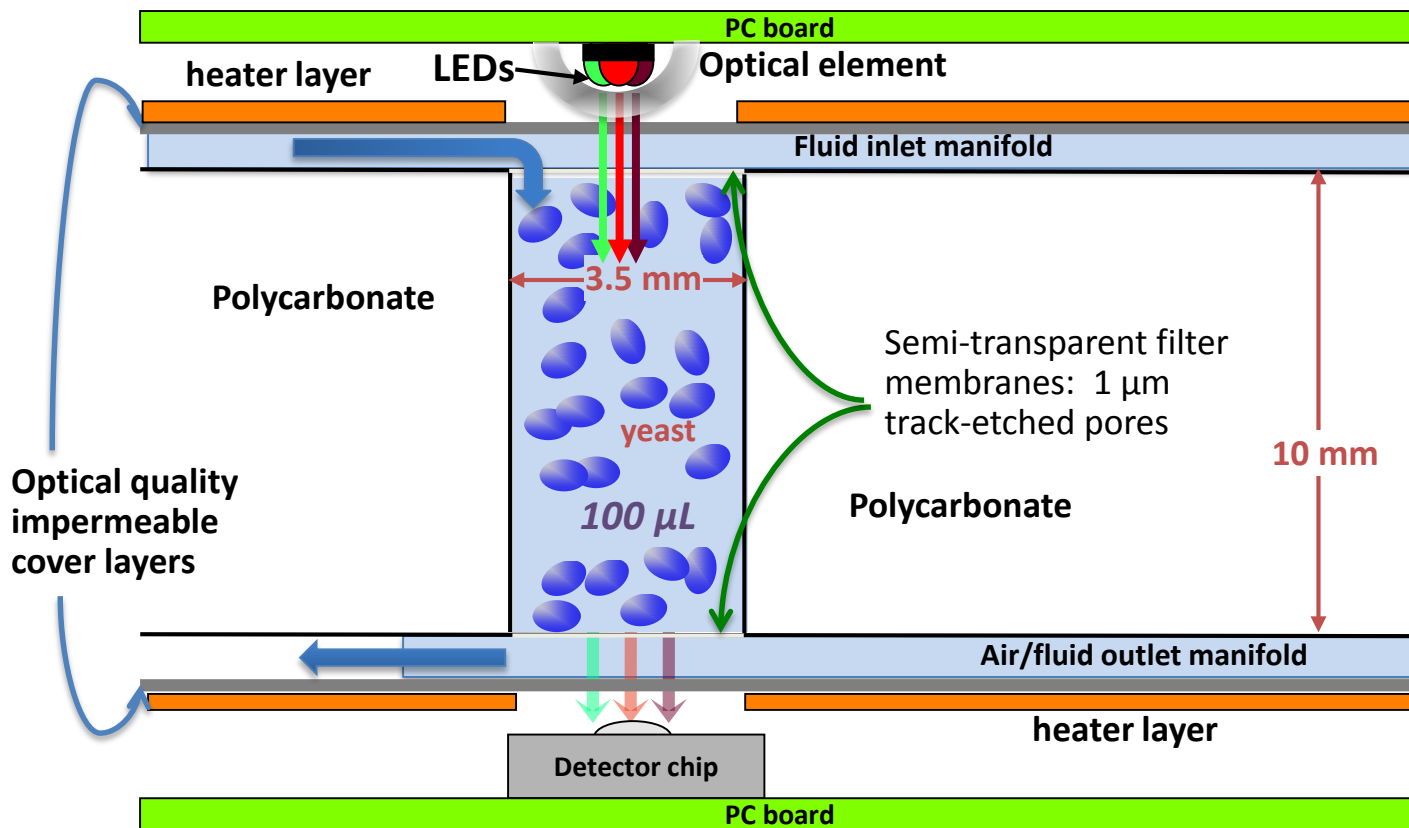

Yeast dried onto μ well walls prior to integration & launch

1 set of 16 μ wells wetted out monthly

3 LEDs (570, 630, 850 nm) and detector, per well, track growth *via* optical density and cell metabolic activity *via* dye color change



BioSentinel/Mars Instrument

Fluidic Subsystem Architecture (1 of 2 identical 9-card units shown)

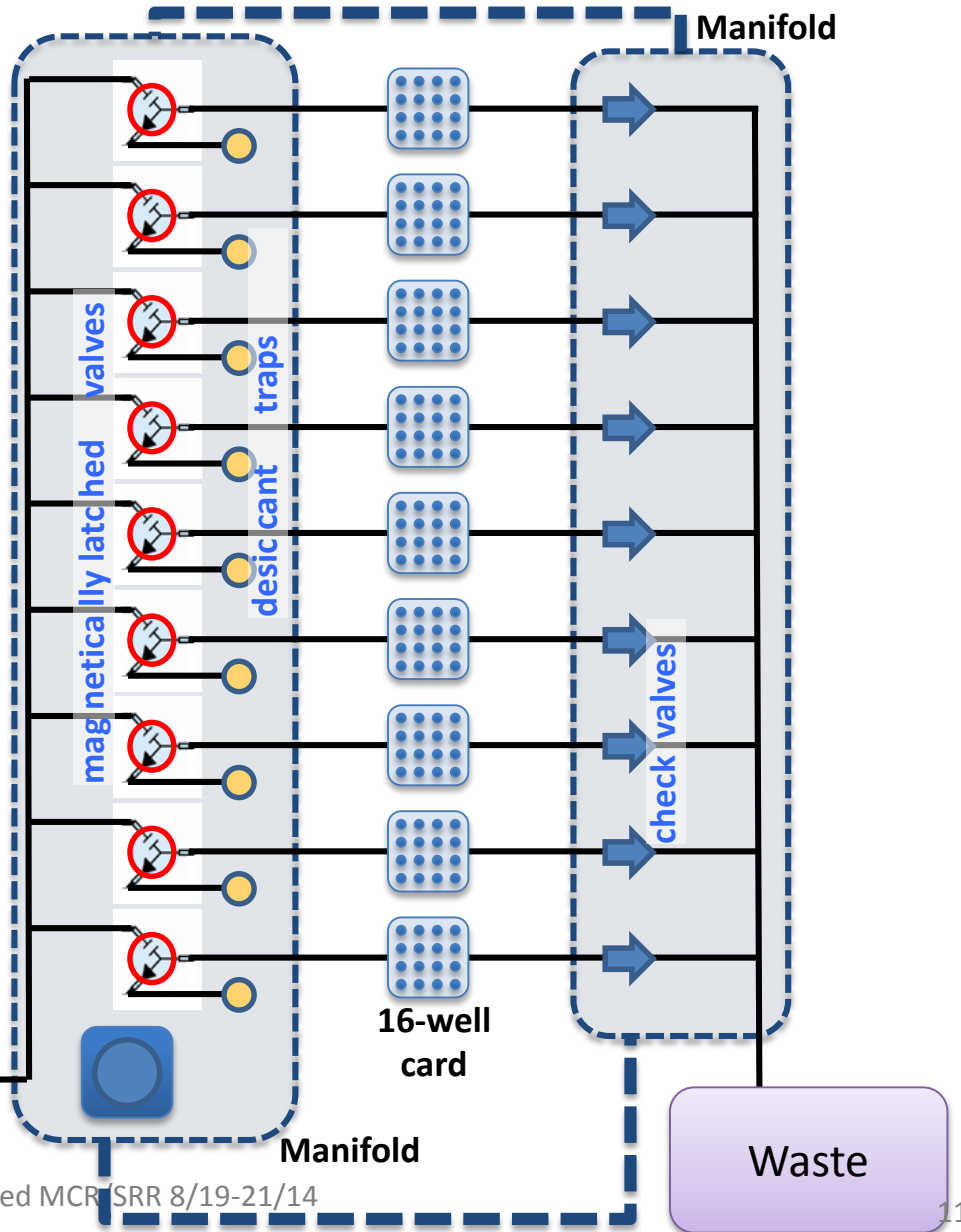
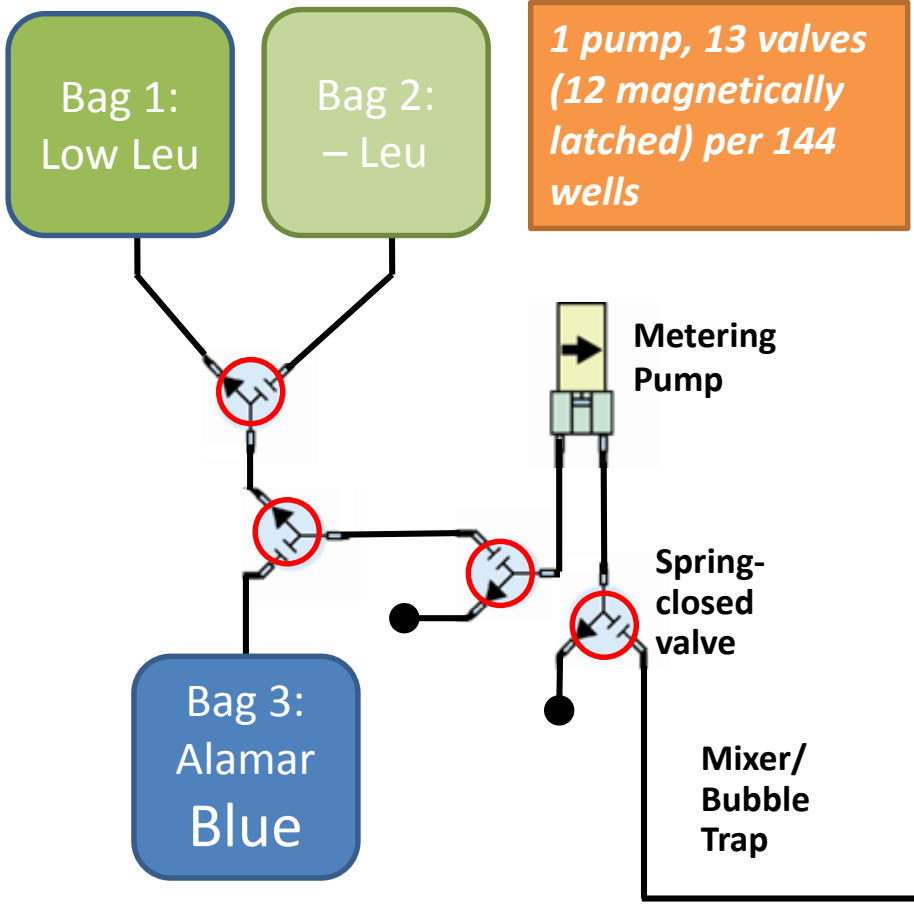



Payload Configuration (cont'd.)

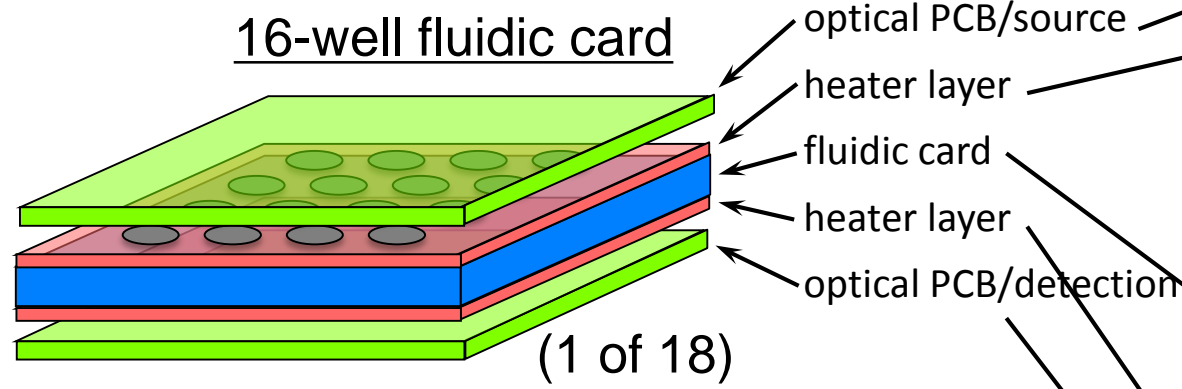

- **Optical absorbance measurement per well**
 - Dedicated 3-color optical system at each well
 - Measure dye absorbance & optical density (cell population)
 - Ground pre-calibration + in-flight “active” cal.
- **Pressure & humidity sensors** in P/L volume
- **Dedicated thermal control system per card**
 - 23° C with 1 ° C uniformity, accuracy, stability
 - 1 temp. sensor per card; closed-loop control

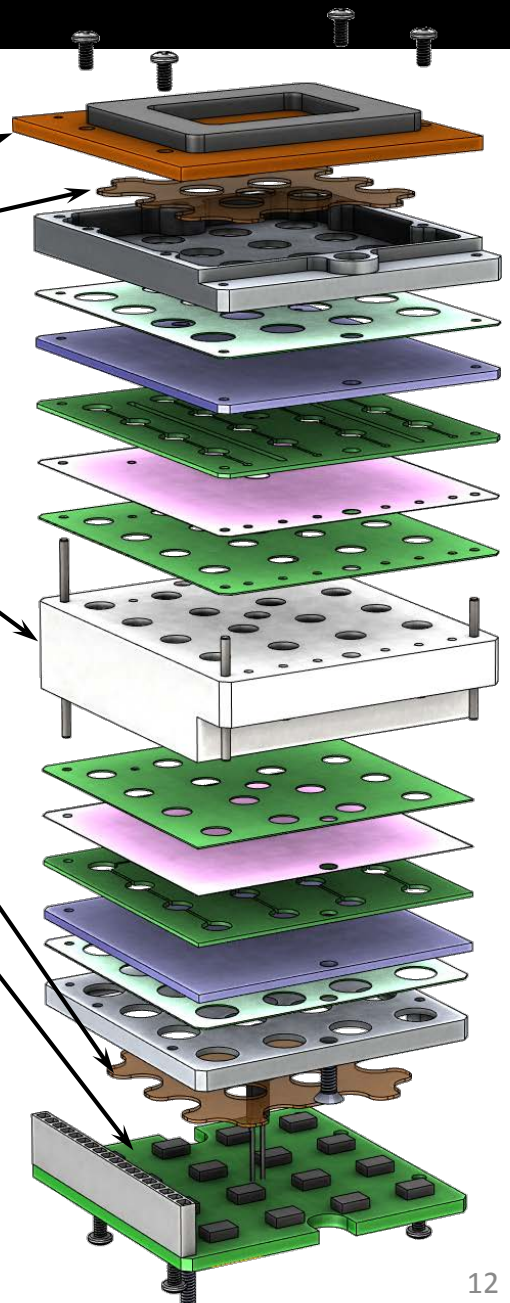



BioSentinel/Mars Instrument

Biology / fluidics / optical / thermal configuration

16-well card
= 1 "set"
(18 sets total)

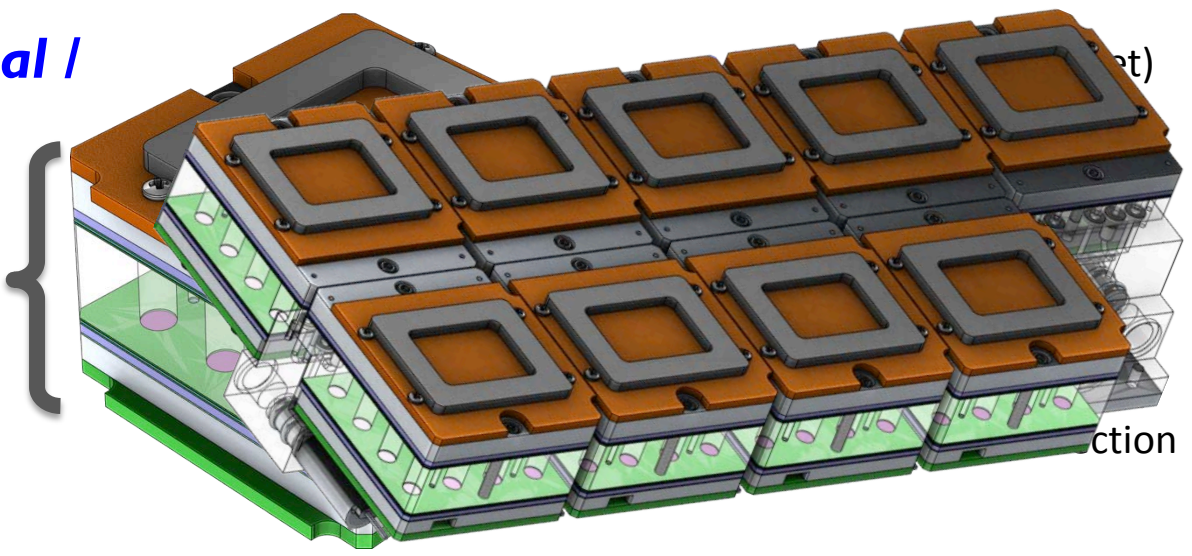

1 atm Payload

Containment

Thermal exchange

~ 4U

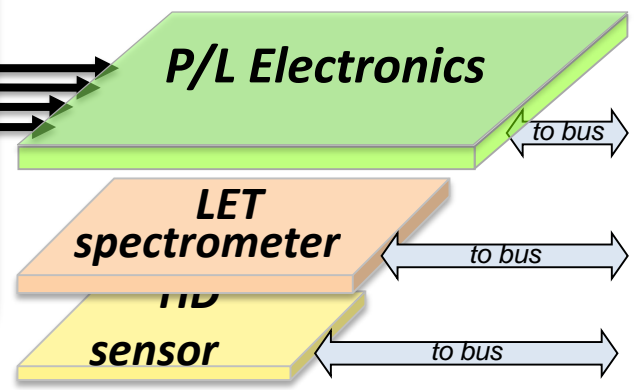
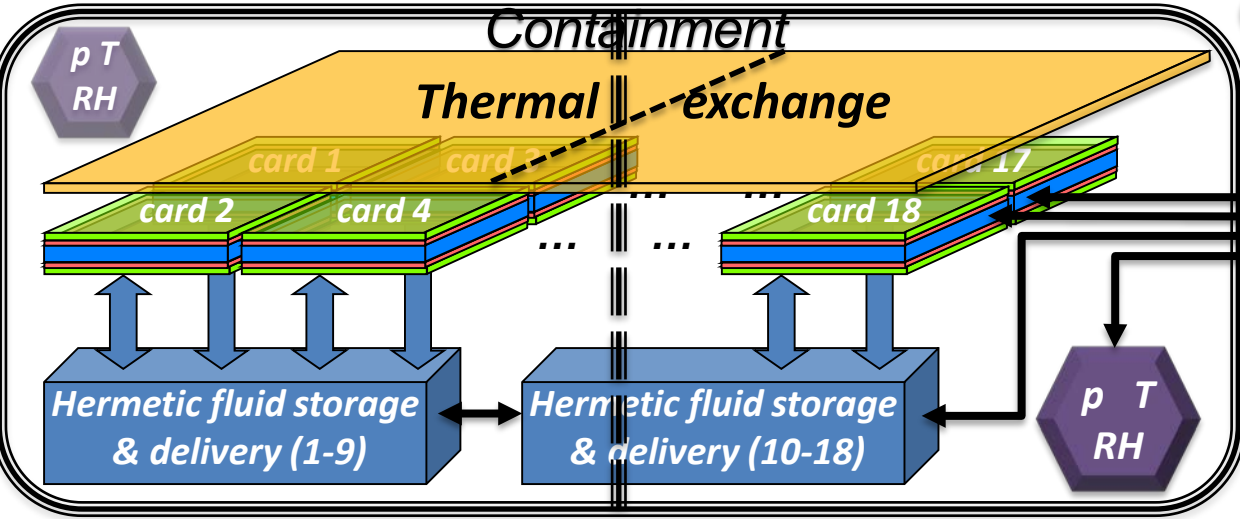



BioSentinel/Mars Instrument

BACK-UPS

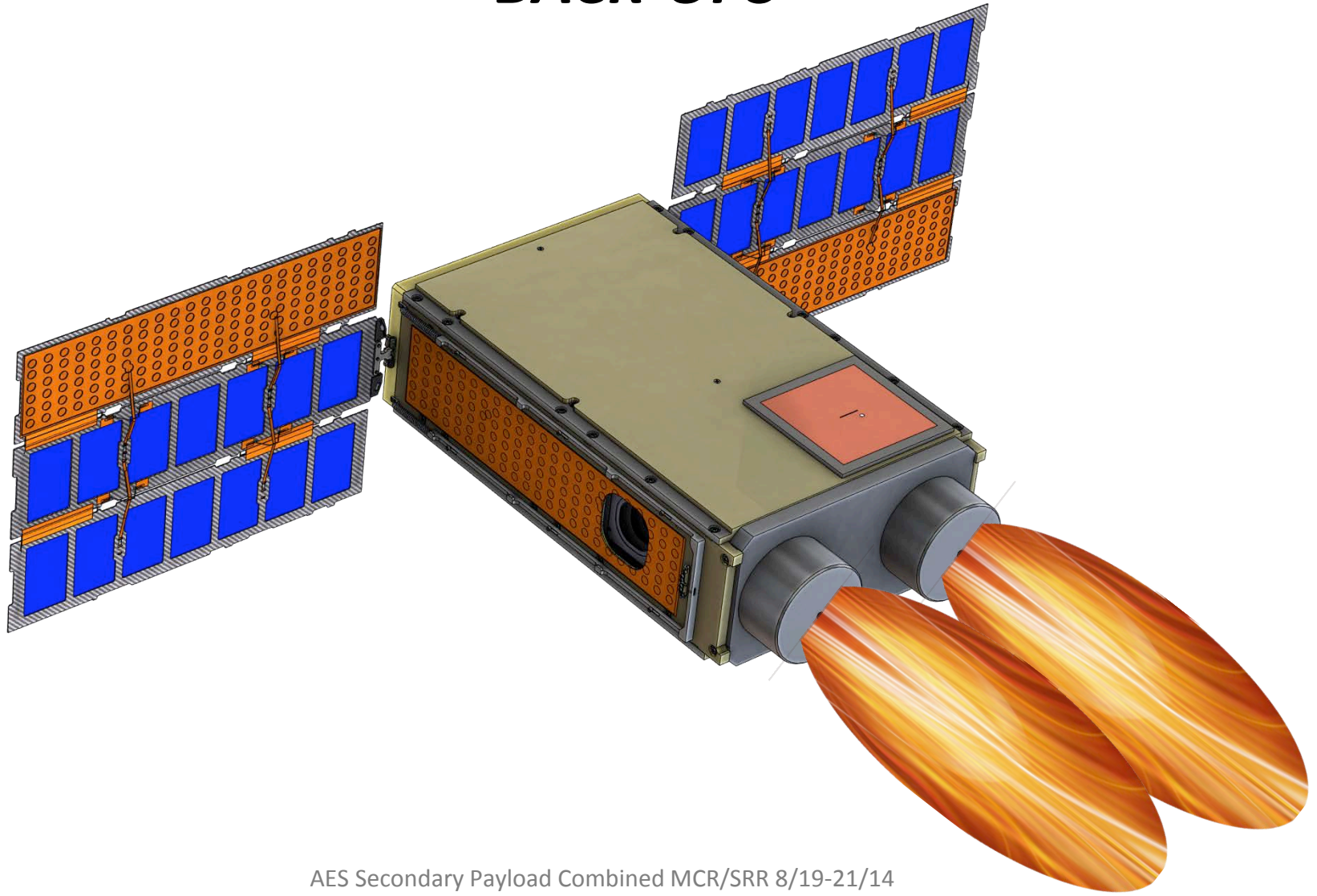



BioSentinel EM-1 Spacecraft

Stowed Configuration

Medium Gain Antenna (MGA)

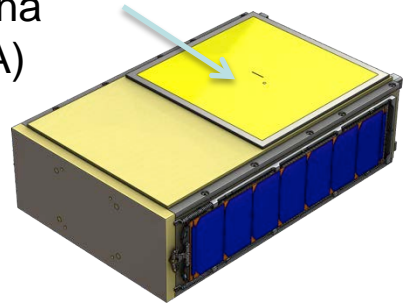

Deployed Configuration (underside)

Deployable/Single Axis Gimbal Solar Arrays

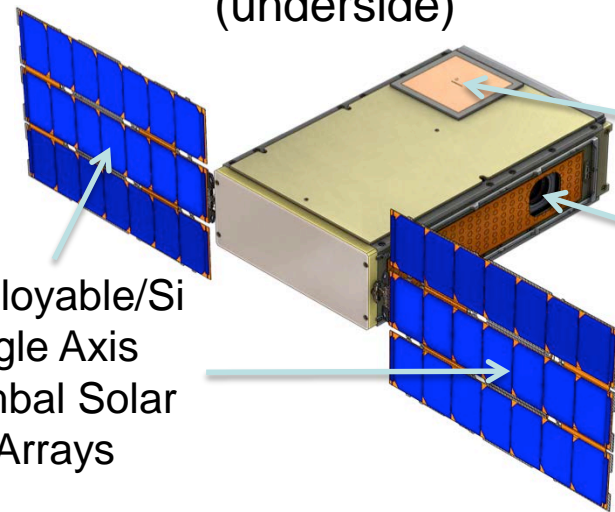

Low Gain Antenna (LGA)

Star Tracker (ST)

Fluidic Card
Each Card has a Set or Bank of 16 μ wells

18 Coplanar Fluidic Cards

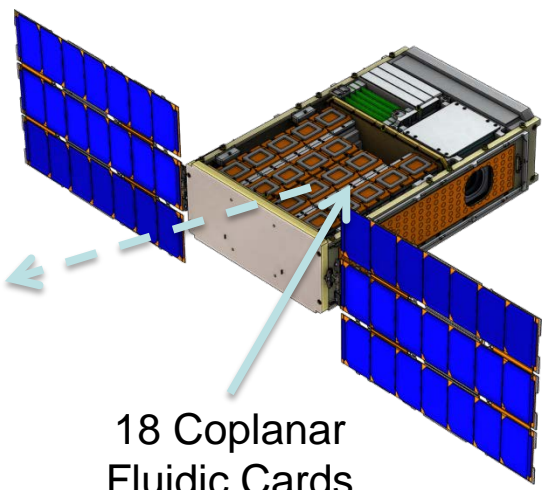

Avionics
Transponder
Propulsion System
Batteries
BioSentinel Payload



BioSentinel/Mars Instrument

Payload Configuration: Thermal Requirements & Design

- 23 ° C biology temp. for “active growth” fluidic card
- ~4 ° C for non-active cards: maintain biological viability
 - “Keep-alive” 4 ° C minimum at all times, cards & reagents
- Minimize temp. gradients in active fluidics card
- Minimize power to heat fluidics during experiment
- Minimize heat flow to surrounding non-active cards
- Kapton heaters + spreader bonded to each card
- **Challenge: no active control** from L-6 mo to deployment

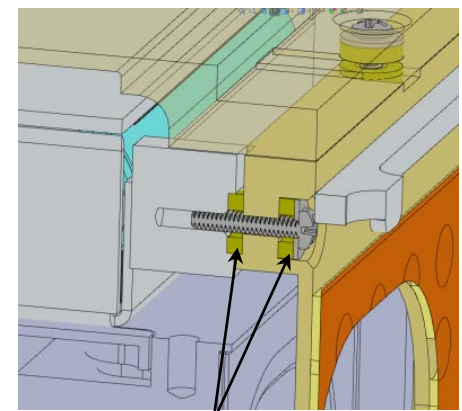

Isolating washers/spacers (Ultem, SS, Al, etc.): **tunable thermal interfaces** enable structural design before complete thermal details

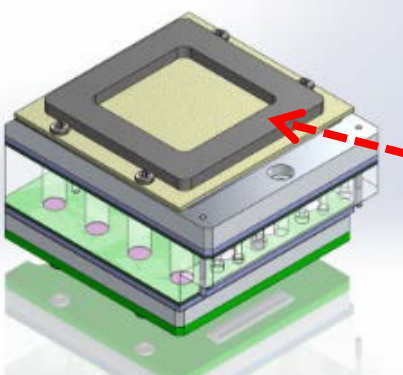

GapPad: tuned thermal path to payload enclosure by choice of pad dimensions

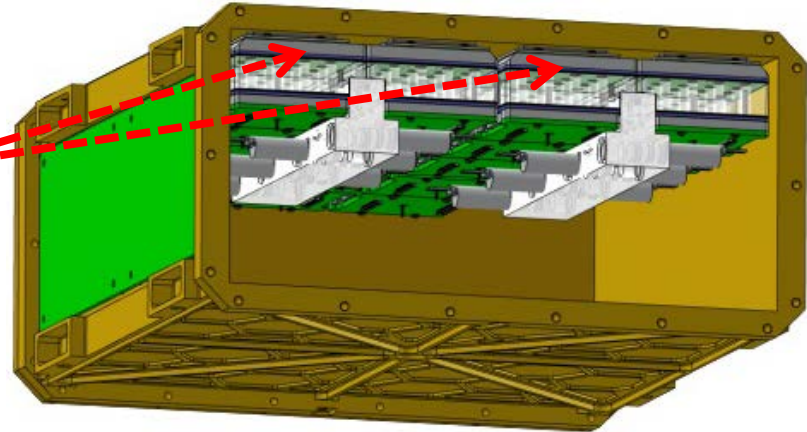

1 of 18 fluidic cards AES Secondary Payload Combined MCR/SRR



Payload Configuration: Thermal Model Results

As-modeled, < 0.5 W to heat single card

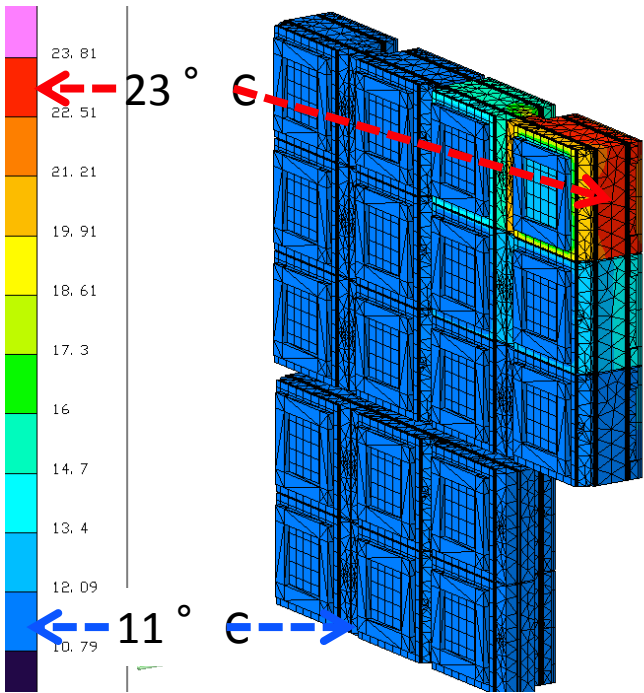
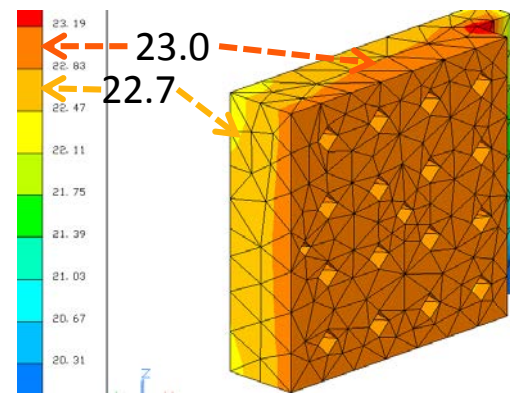

- 46,000 Nodes, 6 heat loads, 18 heaters, 206 contactors; FD & FE objects
- Fluidics card components meshed separately (2200 nodes) at high res.: capture thermal gradients, uniformity

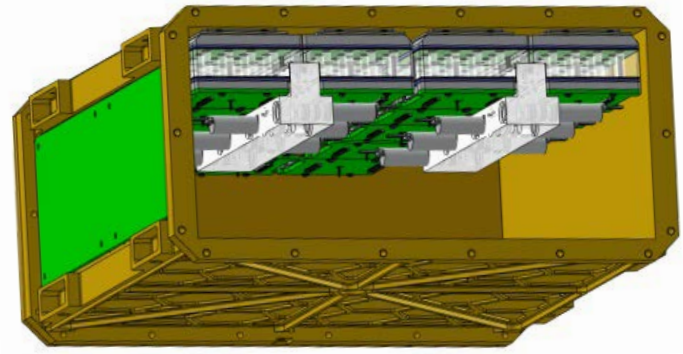



Payload Configuration: Electronics & Components

- **3 Payload Systems: Biosensor, LET spectrometer, TID**
 - Minimize electronics inside hermetic biosensor container
 - Earlier delivery of “in-can” electronics to bio team to start long-term tests
 - Less hardware tied up in long-duration tests
 - Changes less likely within biocompatibility zone
- **Subsystem Components**
 - Optical: 3 discrete LEDs – 0402 SMD pkg, “Y” geometry
 - TAOS intensity-to-freq. detector: 5-6 logs linear dynamic range
 - Thermal: AD590 sensors: easy integration; Kapton flex ckt. heaters
 - Humidity: Sensirion SHT15
 - Pressure: Motorola MPL3115A2
 - TID: Teledyne uDOS001 + charge pump + MSP430 + RS422
 - LET spectrometer: provided by RadWorks team



Payload Configuration: Processor, Interface, Power, Rad.

- **Control and storage provided by bus processor**
 - Implemented as a cFE task
- **Payload Local Processor: baseline MSP430**
 - FRAM, high radiation tolerance
- **Comm. Interface to Bus / Host: RS-422**
 - Simple, robust
 - Serial is standard, easier ground testing
 - RS-485 enhancement (S/W only) for greater functionality
- **Comm. Packet Protocol**
 - CCSDS: standard
- **Power: 5 VDC & unreg (9-28 VDC); multiple ground returns**
- **Rad-hard electronics: Power parts, regulation and switches**
 - Cannot afford power, space, cost for full rad-hard design
 - Total dose inside is low-moderate; spot shielding feasible



BioSentinel/Mars Instrument

Payload Configuration (cont'd.)

• Radiation Sensors

- LET “spectrometer” device: TimePix family solid-state device
 - measures coarse linear energy transfer spectra
 - Operates in time-over-threshold (TOT) mode as Wilkinson-type ADC
 - ❖ *direct energy measurement per pixel*
 - frequent measurement/caching of results; downlink binned LET spectra
 - provide “local space weather” periodic (~ hourly) snapshot

- Total integrating dosimeter (TID): Teledyne μ DOS001
 - ranged analog outputs (low, med, high, log)
 - 15 μ rad res. (~20 s ambient GCR)



Teledyne
dosimeter

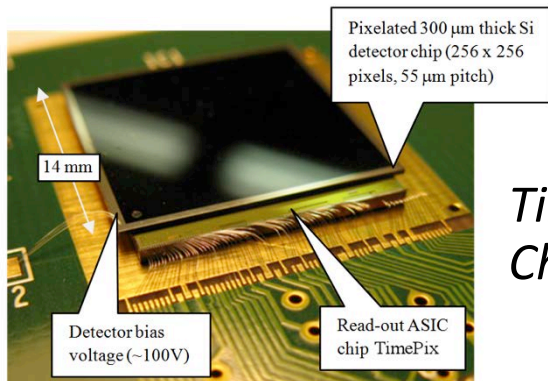

TimePix
Chip

Typical TimePix frame:
256 x 256 x 14 bits
0.25 – 150 keV/ μ m LET range

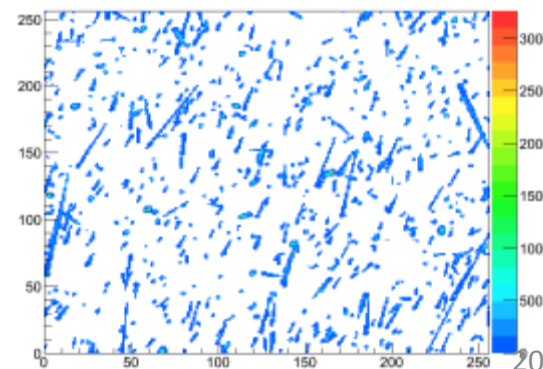



Payload Configuration (cont'd.)

• Solar Particle Event Autonomous Trigger

- Onboard monitor of TID (backups: TimePix shutter (integration) time, ground command)
- Ionizing EM radiation (gamma) precedes particles by ~ hours
 - SPE differentiable from smaller coronal mass ejections
- **Activate “designated SPE set” of 16 fluidic wells**
 - measure radiation biological damage under wet conditions
 - *expected to generate **more damage wet than in dry state***

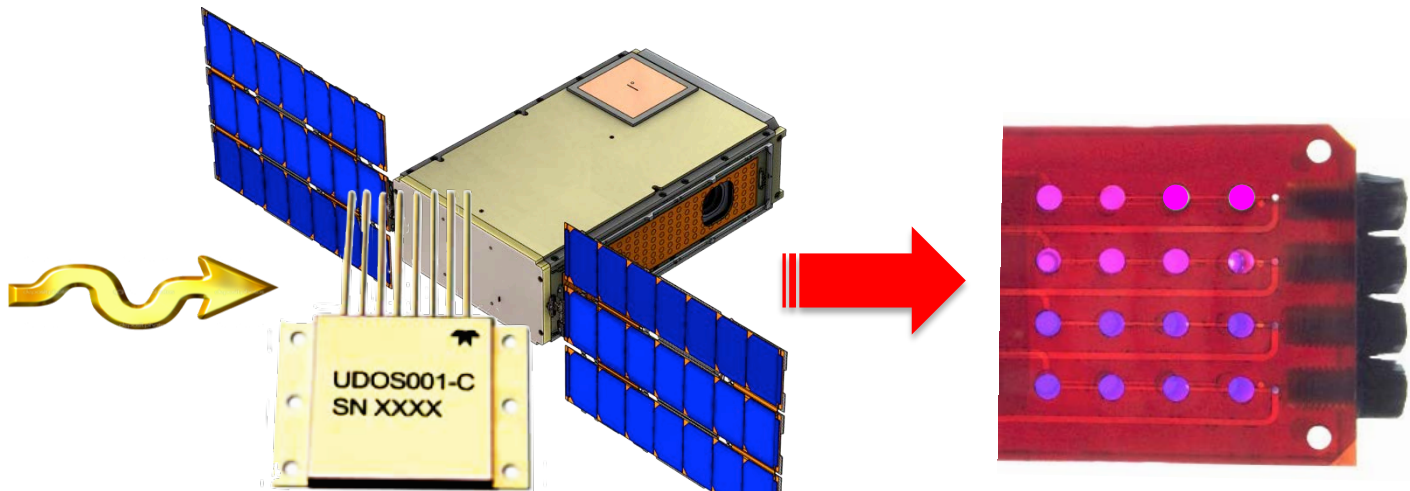



Radiation Environment for EM-1 Mission

Total Ionizing Dose (Si):

Ambient Flux + single Solar Particle Event

4pi Dose at Centre of Spheres (Aluminium)

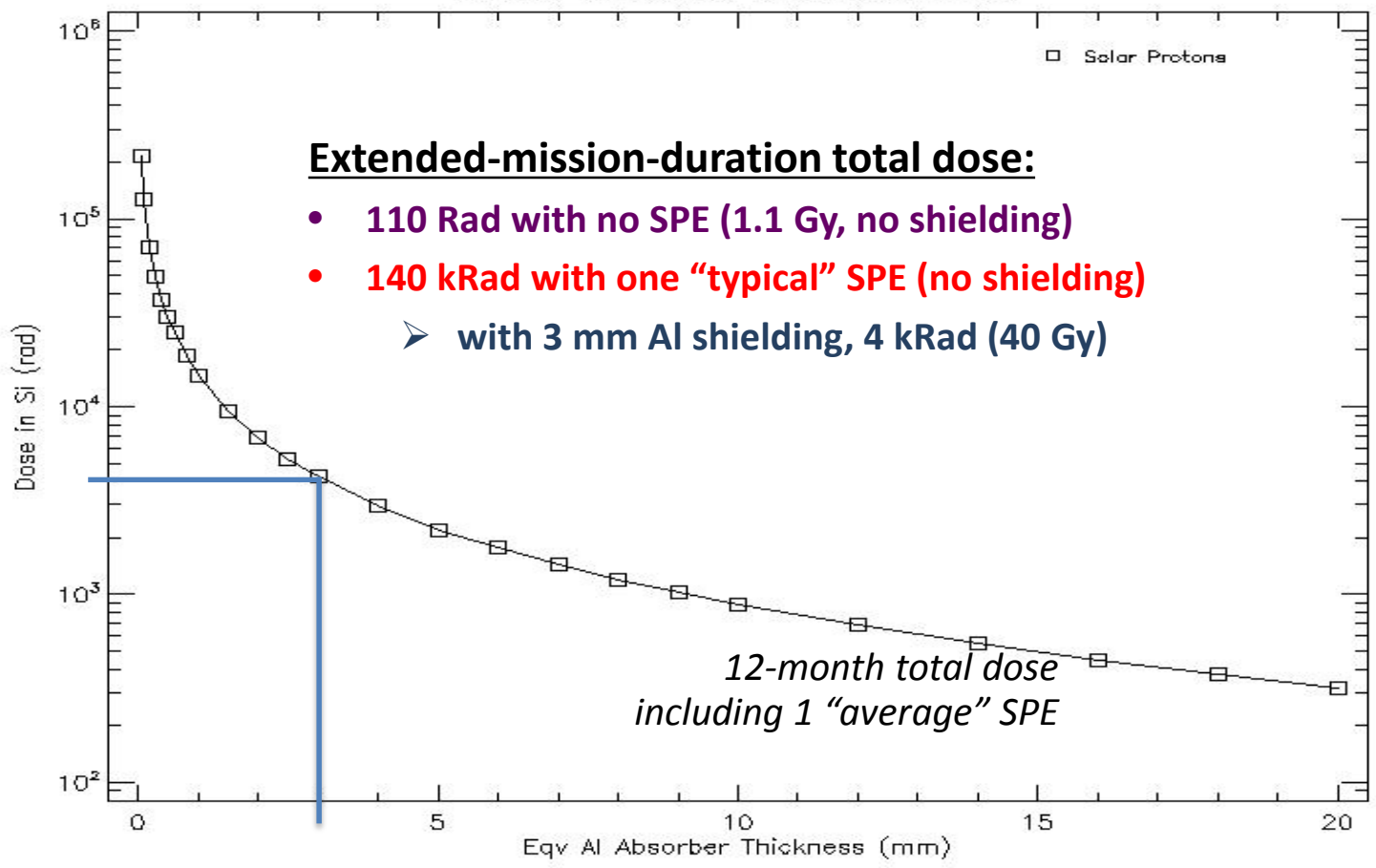

Model:
SHIELDOS
E-2Q



BioSentinel/Mars Instrument

Radiation Environment

LET Flux vs. Shielding thickness, H - U, 1 AU
Solar Energetic Particles + GCR

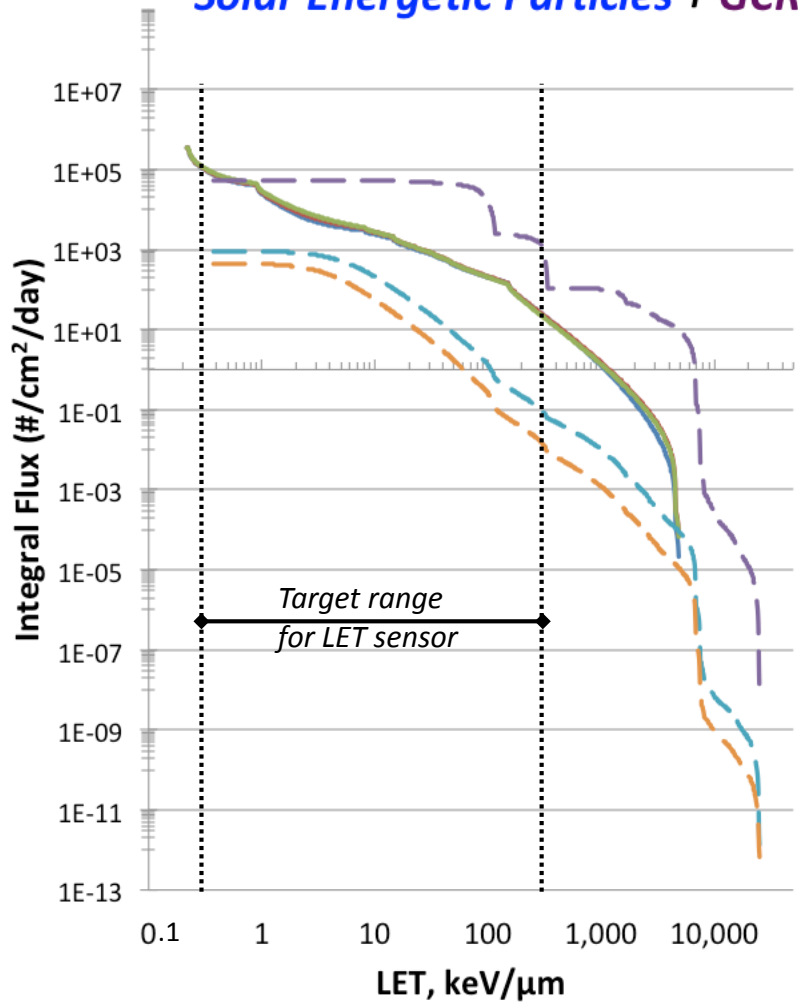

LET Flux vs. Shielding Thickness, H - U, 1 AU
Solar Particle Event + GCR

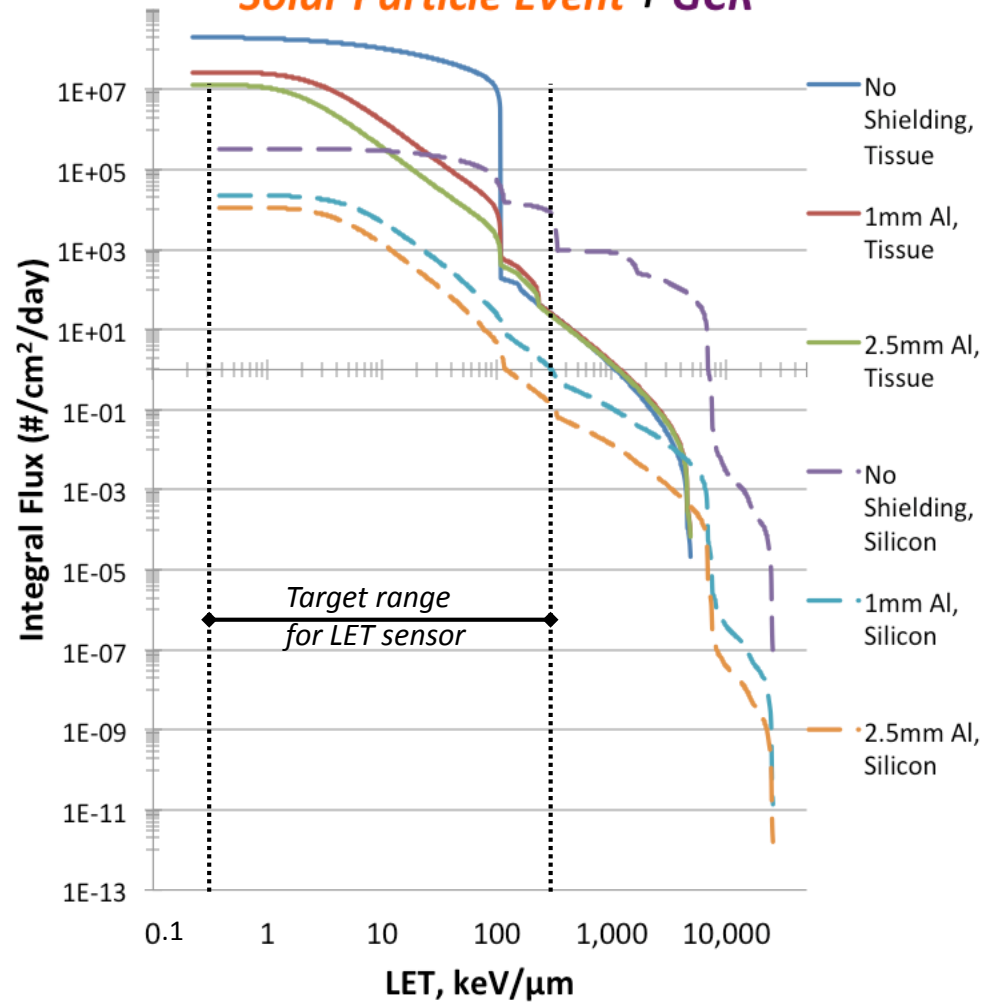



Payload Heritage

- **GeneSat** – overall bio P/L integration; hermetic sealing (3 years)
- **PharmaSat** – optics, thermal, multi-well fluidics, *S. cerevisiae*, biocompatibility, 48 μ wells
- **O/OREOS SESLO, SEVO payloads** – dried organisms, 12-mo. stasis; cell filters in optical path; thermally isolated “bioblocks”; spectral data cache-and-downlink; high-radiation survival:
 > *3.5 years, high-inclination/high-altitude orbit*
- **EcAMSat** – multiple uniform multiwell fluid exchanges; 48 μ wells
- **MisST** – image acquisition payload; peristaltic pump
- **SporeSat** – P/L processor w/ robust S/W
- **JSC RadWorks (CERN to ISS)** – LET spectrometer chip, control/measurement system, S/W to extract radn. spectra
- **LRO** – Teledyne μ DOS001
- **LADEE** – S/C avionics incl. S/W



BioSentinel/Mars Instrument

Payload Subsystem Trades – I: Bio/fluidics

Trade	Options	Complete	Due*	Heritage
Organism storage	<u>Dry</u> , Wet	95%	MCR	Mod.
Refresh media	<u>Yes</u> , No	95%	MCR	Mod.
Sterilization - card	<u>Autoclave</u> , EtO, Other	95%	PDR	Mod.
Sterilization – other components	Gamma, EtO, sterilant	75%	PDR	Mod.
Fluidic component permeability	<u>Low</u> , med., high	65%	PDR	Low
Aerobic growth	<u>Initial</u> , Continuous	40%	CDR	High, low
Oxygenation approach	<u>Pre-saturate</u> ; Heliox; @ wet-out	10%	CDR	Low
Pump(s)	Peristaltic, Inj., <u>Piston</u> , Diaphr.	45%	CDR	Mod., high
Valves	<u>Mag. latching</u> , Continuous pwr.	80%	MCR	Low, high
Fluidic connections	<u>Manifold</u> ; direct tubing cxns.	80%	MCR	Low
Reagent containers	<u>Bags</u> , Rigid containers	90%	MCR	High, mod.
Other components: bubble trap, check valve, desiccant, tubing	Various	50%	PDR	Various
Materials choices: fill, perm., autoclave	Various	50%	PDR	Various
Compartments (fluidics/electronics)	One, <u>two</u> , three	40%	CDR	Low

*“MCR” due date = upon processing MCR inputs & outcome



BioSentinel/Mars Instrument

Payload Subsystem Trades – 2: Bio Measurement etc.

	Trade	Options	Complete	Due	Heritage
Measurement	Measurement Approach	<u>Absorbance</u> ; fluorescence; other	95%	MCR	High
	Choice of wavelengths/LEDs	R/G/B; <u>fR/R/G</u> ; x/y/z	80%	MCR	Mod.
	Choice of detector	<u>TAOS ASIC</u> ; photodiode, other	95%	MCR	High
	Location of cell filters	<u>in optical path</u> , out of path	80%	MCR	High
Thermal	Experiment / stasis temperatures	23 / 23 °C; <u>23 / 4 °C</u>	40%	PDR	Low
	Thermal spreader locations	<u>Top & bottom</u> ; top only	80%	MCR	High
	Thermal spreader approach	<u>Al plate</u> ; flex ckt ground plane	60%	PDR	Low
Sensors	Pressure sensor	<u>Motorola [SporeSat]</u> ; other	100%	MCR	High
	Humidity sensor	<u>Sensirion</u> ; other	90%	MCR	High
	Acceleration & gyro	<u>Use bus IMU</u> ; P/L in-situ	80%	PDR	Mod.
	Temp. sensors: no. & locations	1 per card, int.; 2 per card, ext.	50%	PDR	Low/high
Processor	Choice of processor	<u>MSP430</u> ; PIC32; same as bus; other	80%	CDR	High
	RTOS (SporeSat heritage)	<u>Yes</u> ; no	80%	PDR	Mod.
	Multiple processors in P/L	<u>Yes</u> ; no	90%	MCR	High

*“MCR” due date = upon processing MCR inputs & outcome

R 8/19-21/14
11/13



BioSentinel/Mars Instrument

Payload Subsystem Trades – 3: Physical Radiation Msrmt.

Trade	Options	Complete	Due	Heritage
<i>LET spectrometer choice</i>	<u>TimePix family</u> ; TEPC (gas); other	80%	MCR	High
<i>Measurement frequency</i>	<u>Continuous</u> ; periodic	70%	PDR	Mod.
<i>Onboard storage capacity</i>	3 days – <u>18 months</u>	50%	PDR	--
<i>Integration time adjust</i>	<u>Autotune</u> ; ground cmd.	90%	MCR	High
<i>Conversion to spectra</i>	<u>Onboard S/C</u> ; after downlink	40%	PDR	Low
<i>Frequency of downlinked spectra</i>	1 – 2000/day (<u>24</u>)	40%	PDR	Low
<i>Control / measurement system</i>	“plucked BIRD”; ISS-REM; custom; FitPix	20%	PDR	Various
<i>Controlling processor</i>	Dedicated; P/L; Bus	30%	PDR	Low
<i>No. of LET spectrometers</i>	<u>1</u> , 2, 3, 18	95%	MCR	--
<i>TID sensor</i>	<u>Teledyne uDOS001</u> ; Oxford RadFET	90%	MCR	High
<i>No. of TID sensors</i>	<u>1</u> , 2, 3	90%	MCR	--
<i>SPE Trigger approach</i>	LET; TID; uplink; <u>all</u>	85%	MCR	Mod.

TID = total integrated dose; LET = linear energy transfer; SPE = solar particle event

S/C = spacecraft

P/L = payload



Payload Key Interfaces

- **Payload to Biosentinel Bus: Power, C&DH**
 - also support Payload to ISS, GSE, other S/C bus configurations
- **Payload Power & Processor to Payload Subsystems**
 - Fluidic: pumps, valves, tubing, manifolds, fluidic cards, bags
 - Optical measurement: sources, detectors, fluidics card w/ filters, cells, dye
 - Thermal: heaters, T sensors, fluidics card/biology
 - Sensors: ***RH***, ***p***, radiation TID, radiation LET
- **Payload Thermal:** balance, manage conductive vs. insulating links
 - Bio/fluidics to heaters
 - All P/L components & subsystems to containment vessel
 - P/L containment vessel to cables, S/C bus, structure
- **Payload Mechanical:** all of the above to hermetic containment vessel
- **Payload Subsystems to External Space Environment**
 - Biological & physical radiation sensors; thermal



Payload Key Analyses / Activities prior to PDR

- 95% of trades to $\geq 75\%$; no trades $< 60\%$
- Payload mechanical / thermal: **integrate mech. & thermal models**
- Payload processor & architecture **defined**
 - Payload S/W Build 1 $> 50\%$
- Rad. spectrometer, rad. dosimeter **selected**
 - Rad spectrometer support electronics approach **defined**
 - image-to-spectrum conversion: **on-board vs. ground selected, S/W defined**
- Fluidics: architecture **defined**
 - All fluidic components: lead candidate **identified, tested**
 - Autoclavable card **confirmed** by testing
 - Oxygenation approach defined & **demo'd.**
 - "Initial-aerobic" growth **OK'd**
- Optical measurement subsystem **designed**
- Flatsat complete, **execute 1-card bio experiment**

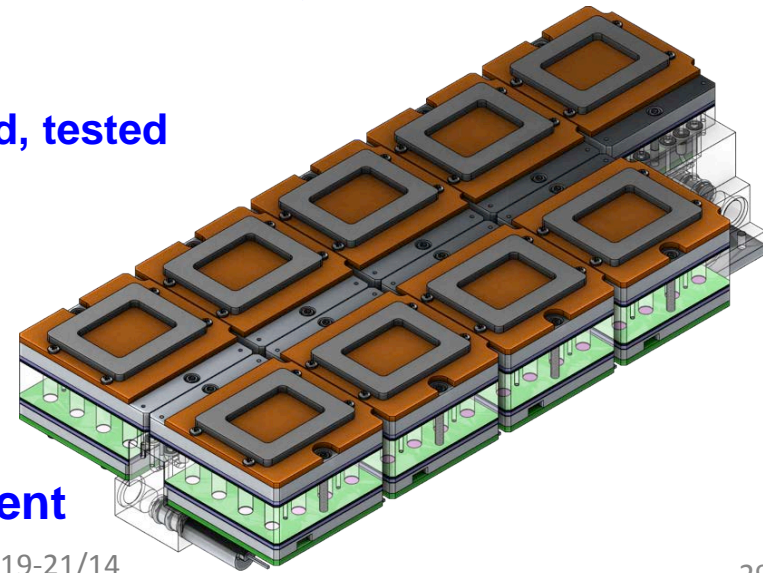



Payload Concerns & Mitigations

Fluidic Card & Subsystem

- Biocompatibility/stasis for various components: up to 24 months
 - **Choose materials known to be compatible; minimize EtO sterilization**
- Fluidic fill from dry state including yeast re-suspension
 - **Good prelim. results; O/OREOS for spore experience; desiccant**
- Adhesive (and other fluidics components): long-term stability: **Test + Heritage**
- Fluid exchange well-to-well uniformity: **Flow rate, duty cycle; EcAMSat heritage**
- Aeration: **Dissolved O2 at laboratory concentrations + bubble trapping**
- Evaporation / bubble formation: **Design, bubble trapping, degassing, hermeticity**
- Environment: 6 months at KSC w/out thermal control, including “sunbathing excursions”
 - **Plenty of MLI on dispenser**

Physical Radiation Measurement Subsystem

- Power consumption of LET spectrometer & supporting electronics
- Size of radiation sensor support electronics
- Data volume from LET spectrometer chips: **Hourly binning by LET, 256 bins → 9 MB/yr**

Payload Software

- Must start immediately. *SporeSat base on which to build*



BioSentinel/Mars Instrument

Payload/Instrument Top-Level Schedule

Date	2014			2015				2016	2017
	Jul	Aug	Sep	Mar	Apr	Aug	Sep	May	May
Milestone	Payload Table-Top Review	MCR/SRR		PDR		CDR		System Integration Review	Ship to KSC
<i>L1 status</i>	Signed								
<i>L2 status</i>	Prelim.		Signed						
<i>L3 status</i>	Draft	Prelim.			Signed				
<i>L4 status</i>		Draft		Prelim.			Signed		
<i>L5 status</i>				Draft		Prelim.		Signed	
<i>System Qual.</i>								Qualified	
State of Development	Trades 50% complete Interfaces and Components Identified	Trades 65% complete Components defined Interfaces defined		Flatsat demonstrated CPU controls components CPU to all interfaces		1st EDU complete		Qual Unit Complete EVT complete	Fligh Unit complete Ground control samples loaded



Proposed LET Spectrometer Prelim. Requirements

Objective: Measure time-resolved LET of charged particles w/ solid-state device

- **Nominal LET range:** 0.2 to 300 keV/ μm • 256 x 256 pixels, ≥ 14 bit depth
- **Target species:** H-1, He-4, C-12, O-16, Mg-24, Si-28, Fe-56
- **Detector volume:** 14 mm x 14 mm x 0.3 mm
- **Integration (“shutter”) time:** dynamic feedback, target frames $\sim 3\%$ full
- **Range of per-frame integration time:** 0.3 - 30 sec
- **Measurement duty cycle:** continuous over mission (up to 18 mo)
- **Power:** ≤ 1.5 W total power in active mode; ≤ 0.5 W dissipated on sensor chip
- **Voltage input:** 5-6 VDC
- **Size:** 1 cm x 2 cm x 6 cm up to 1 cm x 7 cm x 7 cm • **Mass:** ≤ 0.25 kg
- **S/W:** converts each “frame” to a binned tally of radiation events:
 - **256 bins** cover 0.2 to 300 keV/ μm ; **bit depth:** 32; **bin width** $\sim 3\%$ of center LET
 - *All frames per hour co-binned to provide one 256-bin hourly “spectrum” of LET events for onboard storage, downlink*
- **Sensor to S/C Bus Communication:** ethernet or serial (RS-422 preferred)
- **Data generated:** 9 MB/yr

Onboard processor may be available to host data processing