

*W. C. Isley*

NASA TR R-128



# TECHNICAL REPORT

R-128

STUDY OF AN AUTOMATIC SYSTEM FOR CONTROL OF THE  
TERMINAL PHASE OF SATELLITE RENDEZVOUS

By Edgar C. Lineberry, Jr., and Edwin C. Foudriat

Langley Research Center  
Langley Air Force Base, Va.

W.C. ISLEY CODE 623  
NASA GSFC RECD.  
CATALOG NO

**ADVANCE  
COPY**

NATIONAL AERONAUTICS AND SPACE ADMINISTRATION

WASHINGTON

1962

NA

NATIONAL AERONAUTICS AND SPACE ADMINISTRATION

---

TECHNICAL REPORT R-128

---

STUDY OF AN AUTOMATIC SYSTEM FOR CONTROL OF THE  
TERMINAL PHASE OF SATELLITE RENDEZVOUS

By Edgar C. Lineberry, Jr., and Edwin C. Foudriat

ABSTRACT

An analytical and simulation study was conducted of an automatic system to control the terminal phase of rendezvous between two space vehicles. The system employs switching and thrust orientation criteria based upon relative-motion parameters first to establish a collision course and then to reduce the range and range rate to zero simultaneously. Techniques are developed for employing either modulated thrust or on-off thrust at a constant level. Results of the study indicate that the automatic system can effectively control rendezvous over a wide range of initial conditions and can utilize the available fuel in a very efficient manner.

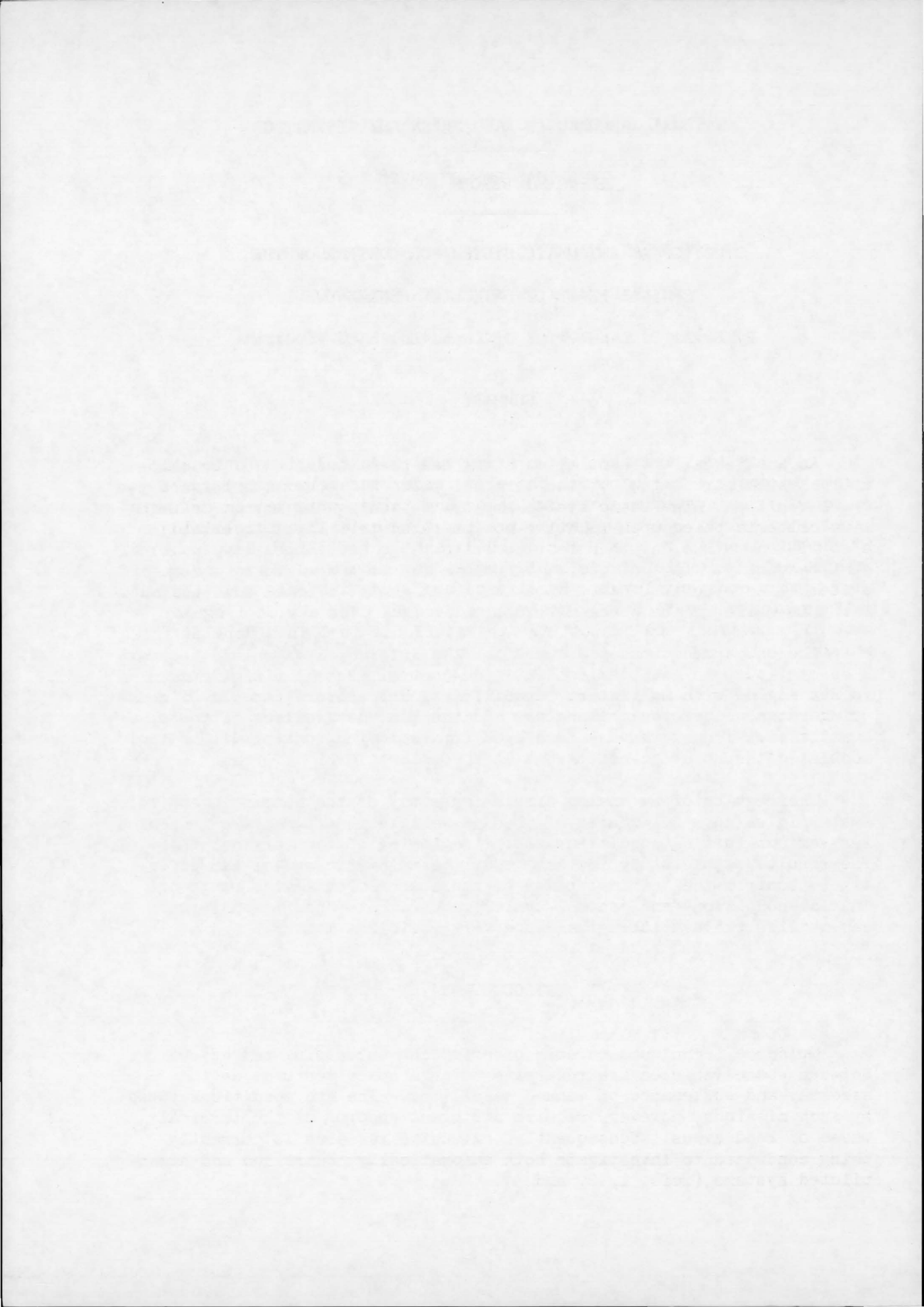

NATIONAL AERONAUTICS AND SPACE ADMINISTRATION

---

TECHNICAL REPORT R-128

---

STUDY OF AN AUTOMATIC SYSTEM FOR CONTROL OF THE  
TERMINAL PHASE OF SATELLITE RENDEZVOUS

By Edgar C. Lineberry, Jr., and Edwin C. Foudriat

SUMMARY

An analytical and simulation study has been conducted of an automatic system for control of the terminal phase of rendezvous between two space vehicles. The basic system employs switching and thrust orientation criteria based upon relative-motion parameters first to establish a collision course and then to reduce the range and range rate to zero simultaneously. In addition, a technique has been devised by which the system effects control based upon the total amount of fuel available for this phase of the space mission.

The onboard equipment assumed for the intercepting vehicle includes a special-purpose computer, an attitude-control system, a single main rocket engine with multistart capabilities, and sensors capable of measuring range, line-of-sight angles, and the time derivatives of these quantities. Techniques are developed for employing control with either modulated thrust or on-off thrust at a constant level.

The results of an analog simulation study of the automatic control system in which a six-degree-of-freedom vehicle is assumed are presented for various initial conditions at the beginning of the terminal phase. The results of the study indicate that the automatic system can effectively control the terminal phase of rendezvous over a wide range of initial conditions and control-system requirements and, in addition, can utilize the available fuel in a very efficient manner.

INTRODUCTION

Guidance techniques capable of effecting successful rendezvous between space vehicles are requisite to such space ventures as the assembly and sustenance of manned satellites. The end conditions posed by such missions, however, require stringent control of the terminal phase of rendezvous. Consequently, extensive research is currently being conducted to investigate both automatically controlled and human-piloted systems (refs. 1, 2, and 3).

In order to achieve a successful rendezvous, two objectives must be attained during the terminal phase. The intercepting vehicle must be placed on a course which brings about eventual contact with the target vehicle. Also, a braking procedure must be employed so that the relative range and range rate are reduced to zero simultaneously. In addition, it is desirable to attain these conditions with a minimum of fuel expended. A study has been made of an automatic control system to attain these objectives.

The six parameters required by the system are range, line-of-sight angles, and the time derivatives of these quantities. Based on these parameters, a technique for establishing a collision course and a predictor logic to control the initiation of braking are developed. The results of an analog simulation study of the automatic control system in which a six-degree-of-freedom vehicle is assumed are presented for various initial conditions. Both modulated thrust control and on-off thrust control at a constant level during the braking maneuver are investigated.

#### SYMBOLS

The English system of units is used in this study. In case conversion to metric units is desired, the following relationships apply: 1 foot = 0.3048 meter, and 1 statute mile = 5,280 feet = 1,609.344 meters.

$A_1, A_2$	acceleration switching limit gains
$a$	acceleration, ft/sec <sup>2</sup>
$c_1$	proportional control gain
$F$	force, lb
$K_1, K_2$	attitude control system gains
$m$	instantaneous mass of ferry, slugs
$R$	distance along line of sight from satellite to ferry, statute miles or ft
$T$	rocket thrust, lb
$t$	time, sec
$V$	relative velocity, ft/sec

$X, Y, Z$	axes of reference frame
$x, y, z$	coordinates of reference frame
$\alpha$	angle subtended by line of sight and its projection on $X_1 Y_1$ -plane, deg
$\beta$	angle subtended by projection of line of sight on $X_1 Y_1$ -plane and $X_1$ -axis, deg
$\delta$	angle subtended by thrust vector and line of sight, deg
$\Delta$	denotes differential quantity
$\epsilon$	limited attitude error signal, deg
$\theta, \phi, \psi$	pitch, roll, and yaw angles, respectively, deg

## Subscripts:

a	available
b	body axis of ferry
c	command
i	inertial axis
N	normal to line of sight
o	initial value
req	required
std	standard
$x, y, z$	relative to reference axis, particularized by additional subscript

A dot over a quantity denotes first derivative with respect to time; two dots denote second derivative with respect to time.

A bar over a quantity denotes a vector.

## TERMINAL GUIDANCE TECHNIQUES

For the guidance concept developed in this paper, the intercepting vehicle (hereinafter known as the ferry) is assumed to have a single main engine with multistart capabilities, an attitude control system, a special-purpose computer to handle the guidance logic, and equipment capable of sensing the relative motion between the two vehicles. The development includes techniques for employing either modulated thrust control or on-off thrust control at a constant level.

### Equations of Motion

For the terminal phase of rendezvous, only the relative motion existing between the two vehicles is of interest. At system "lock-on" a nonrotating set of reference axes is established with the origin in the target vehicle (hereinafter known as the satellite). The  $X_1$ -axis passes through the ferry and the  $Y_1$ -axis (direction arbitrary) and  $Z_1$ -axis complete a right-handed, orthogonal frame. Referenced to this inertial frame, the initial and future positions of the ferry are shown in figures 1(a) and 1(b), respectively.

The only force assumed to influence the relative motion between the two vehicles is rocket motor thrust. In reference 4, the gravity differential between space vehicles has been shown to be very small for the terminal phase of rendezvous. Other investigations (for example, ref. 2) have shown that for short rendezvous time periods the effects of the gravity differential are negligible. With these assumptions, the equation defining the relative motion between the ferry and satellite is

$$\ddot{\mathbf{R}} = \frac{\mathbf{F}}{m} \quad (1)$$

In order to solve equation (1) the components of thrust in the ferry body-axis system must be resolved to components in the inertial frame. (See fig. 2.) In order to resolve these components, the rotational equations of motion of the vehicle (Euler's equations) must be solved so that the Euler angles in the order of rotation  $\psi$ ,  $\theta$ , and  $\phi$  are obtained. (See any standard text on dynamics such as ref. 5.) Since it is logical to assume the thrust is along the  $X_b$ -axis,

$$F_{y,b} = F_{z,b} = 0 \quad (2)$$

Therefore, equation (1) defining the relative motion between the ferry and satellite becomes

$$\ddot{x}_1 = - \frac{F_{x,b}}{m} \cos \psi \cos \theta \quad (3)$$

$$\ddot{y}_1 = - \frac{F_{x,b}}{m} \sin \psi \cos \theta \quad (4)$$

and

$$\ddot{z}_1 = \frac{F_{x,b}}{m} \sin \theta \quad (5)$$

The components  $\dot{R}$ ,  $\dot{R}\alpha$ , and  $\dot{R}\beta \cos \alpha$  are of interest for control of the terminal phase of rendezvous. These components may be obtained from the linear velocity components  $\dot{x}_1$ ,  $\dot{y}_1$ , and  $\dot{z}_1$  by the following equations (see ref. 2):

$$\dot{R} = \dot{x}_1 \cos \alpha \cos \beta + \dot{y}_1 \cos \alpha \sin \beta - \dot{z}_1 \sin \alpha \quad (6)$$

$$\dot{R}\alpha = -\dot{x}_1 \sin \alpha \cos \beta - \dot{y}_1 \sin \alpha \sin \beta - \dot{z}_1 \cos \alpha \quad (7)$$

and

$$\dot{R}\beta \cos \alpha = -\dot{x}_1 \sin \beta + \dot{y}_1 \cos \beta \quad (8)$$

#### Control of Velocity Components Normal to Line of Sight

In order to establish a collision course with the satellite, the ferry must reduce its normal velocity components,  $\dot{R}\alpha$  and  $\dot{R}\beta \cos \alpha$ , to zero during the rendezvous maneuver. One such correction procedure is to orient the thrust vector opposite the resultant vector of  $\dot{R}\alpha$  and  $\dot{R}\beta \cos \alpha$ . This technique would result in the minimum amount of fuel required for establishing a collision course since  $\dot{R}\alpha$  and  $\dot{R}\beta \cos \alpha$  would be reduced to zero simultaneously. The magnitude of the range rate producing closure would not be altered during such a



Since the range vector lies initially along the  $X_1$ -axis, with proper thrust control the maximum values of  $\alpha$  and  $\beta$  will be very small. Consequently, the command angles can be simplified (and the computational requirements reduced) as follows:

$$\psi_c \approx - \frac{R\dot{\beta}}{|\dot{R}\dot{\beta}|} 90^\circ \quad (9)$$

and

$$\theta_c \approx -\tan^{-1} \frac{R\dot{\alpha}}{|\dot{R}\dot{\beta}|} \quad (10)$$

In order to control the vehicle, an attitude control system is used to attain the angles obtained in equations (9) and (10). (The attitude control system used in the present study is given in the appendix.) When these angles are attained, vehicle thrust is applied until the resultant normal velocity component is reduced to some threshold value (as near zero as possible). Further correction is then prevented by increasing the value of the threshold, and the residual component can be eliminated during a subsequent braking maneuver by properly aligning the thrust

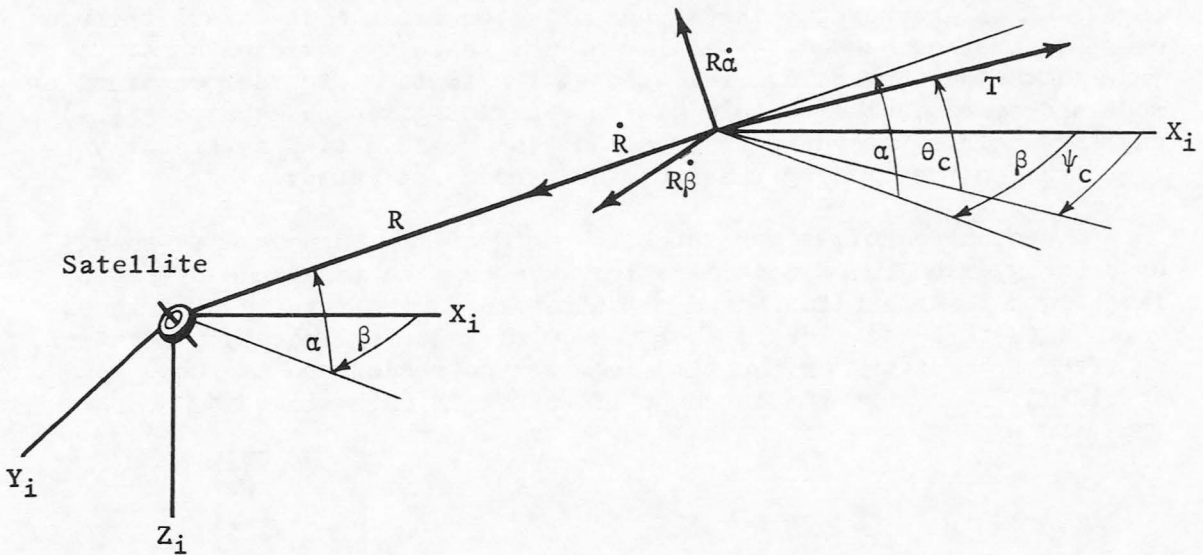

Sketch 2

vector with vehicle command angles (see sketch 2)

$$\psi_c = \beta - c_1 R\dot{\beta} \quad (11)$$

and

$$\theta_c = \alpha - c_1 R\dot{\alpha} \quad (12)$$

where  $c_1$  represents the control system gain.

The result of using the simplified orientation angles during the initial normal velocity correction maneuver will be to increase slightly the magnitude of the range rate since a small component of thrust is applied along the line of sight toward the satellite. If the corrections are made rapidly enough, however, the increase in  $\dot{R}$  is negligible.

The previous discussion has presented the control equations determining the orientation of the thrust vector during the initial correction phase and during the braking phase. In order to implement the system, however, certain additional factors must be taken into account. First, it is necessary to allow time for the vehicle to be oriented within certain limits before thrust is applied. Second, a method is required to determine when the angular velocities of the line of sight have been reduced sufficiently to allow transition to the braking phase. The method for accomplishing these steps is shown in figure 3. Switching logics "A" and "B" (depicted as relay amplifiers) are used in the system to compare the values of  $\dot{R}\alpha$  and  $\dot{R}\beta$  with preselected threshold values. If the magnitude of the velocity components is greater than the threshold values, the system switches to the thrusting mode and commands the attitude angles given by equations (9) and (10). The yaw and pitch attitude errors are summed and compared with a threshold value in switching logic "C" which prevents thrusting until the vehicle is in an attitude close to that commanded. When the normal velocity components have been reduced to the threshold level, the system switches to the nonthrusting mode and commands the vehicle attitude angles given by equations (11) and (12). This procedure insures that the vehicle will be properly oriented for the braking phase of the rendezvous maneuver.

A second technique for establishing a collision course is based upon energy-management considerations whereby the magnitude of the range rate is either increased or decreased during this initial maneuver. With this technique either the total velocity increment required to effect rendezvous or the time required to rendezvous can be specified. As shown in sketch 3, if thrust is maintained in

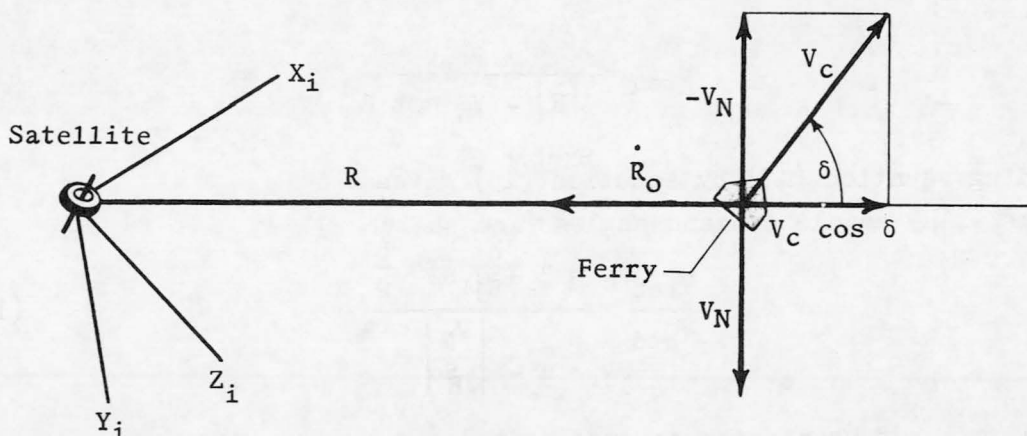

Sketch 3

the plane containing  $\dot{R}_O$  and  $V_N$  at an angle  $\delta$  with the line of sight until

$$V_C \sin \delta = V_N \quad (13)$$

a collision course will be established. The total velocity increment required to effect rendezvous is the sum of the initial correction  $V_C$  (which offsets  $V_N$  and at the same time changes the range rate) and a final braking velocity which removes the remaining  $\dot{R}$ :

$$V_{\text{req}} = V_C + |\dot{R}_O| - V_C \cos \delta \quad (14)$$

It is readily apparent that the time required to rendezvous is directly dependent upon the magnitude of the range rate once a collision course has been established. The interrelationship between the velocity and time required to rendezvous can be shown in the following manner.

Using as a reference standard the velocity and time requirements associated with the initial correction normal to the line of sight ( $\delta = 90^\circ$ ) gives

$$V_{\text{std}} = |\dot{R}| + |V_N| \quad (15)$$

and

$$t_{\text{std}} = \frac{R}{|\dot{R}|} \quad (16)$$

For the control technique based upon specifying either the velocity or time, substituting the value of  $V_C$  from equation (13) into equation (14) gives

$$V_{\text{req}} = |\dot{R}| + V_N \tan \frac{\delta}{2} \quad (17)$$

Also,

$$t_{\text{req}} = \frac{R}{|\dot{R}| - V_N \cot \delta} \quad (18)$$

Dividing equation (17) by equation (15) gives

$$\frac{V_{\text{req}}}{V_{\text{std}}} = \frac{1 + \frac{V_N}{|\dot{R}|} \tan \frac{\delta}{2}}{1 + \left| \frac{V_N}{\dot{R}} \right|} \quad (19)$$

and dividing equation (16) by equation (18) gives

$$\frac{t_{\text{std}}}{t_{\text{req}}} = 1 - \frac{V_N}{|\dot{R}|} \cot \delta \quad (20)$$

The relationship between the velocity and time requirements is presented in figure 4 for various values of  $V_N/\dot{R}$  and  $\delta$ . For  $\delta$  less than  $90^\circ$ , the magnitude of the range rate is decreased during the initial maneuver to establish a collision course; for  $\delta$  greater than  $90^\circ$ , the magnitude of the range rate is increased. The convergence of the curves at

$$\frac{V_{\text{req}}}{V_{\text{std}}} = \frac{t_{\text{std}}}{t_{\text{req}}} = 1$$

represents the operation of the basic system ( $\delta = 90^\circ$ ). The value of  $\delta$  and the corresponding value of  $V_N/\dot{R}$  for which

$$\frac{t_{\text{std}}}{t_{\text{req}}} = 0$$

represents the condition for which rendezvous is not possible since for this condition the velocity increment commanded equals the magnitude of the total relative velocity vector and the time required approaches infinity. This condition does, however, afford a reference for the operation of the system because it represents as a limiting case the absolute minimum fuel required to perform the rendezvous. Thus, for example, if the initial conditions are such that the ratio of the resultant normal velocity to the range rate is 0.6 and the velocity increment specified for rendezvous is 80 percent of the standard velocity increment, the time required to rendezvous would be twice the standard time. However, the system would effect rendezvous with a velocity increment approximately 10 percent greater than the absolute minimum. For this case the absolute minimum is 27 percent less than the standard velocity increment. Thus, at the expense of time, a 20-percent savings in fuel could be realized in this particular case by such a system.

The proper orientation of the thrust vector will first be determined by specifying the velocity increment based upon the amount of fuel available for the rendezvous maneuver. Equating the total velocity increment available to the system and the velocity increment required for rendezvous as given by equation (17) gives

$$V_a = |\dot{R}| + V_N \tan \frac{\delta}{2} \quad (21)$$

Solving for  $\delta$  yields

$$\delta = 2 \tan^{-1} \frac{V_a - |\dot{R}|}{V_N} \quad (22)$$

Instead of integrating the acceleration during the correction to determine the instantaneous value of  $V_a$ , the orientation angle can be based upon the initial conditions:

$$\delta = \left( 2 \tan^{-1} \frac{V_a - |\dot{R}|}{V_N} \right)_0 = \text{Constant} \quad (23)$$

Control based upon the available fuel would insure not only a very efficient energy-management scheme but also would minimize the time in which rendezvous could be effected. In addition, immediate indication is obtained (from eq. (22)) if sufficient fuel is available for the rendezvous maneuver.

The orientation of the thrust vector based upon the time required to rendezvous can be determined from equation (20) as follows:

$$\delta = \tan^{-1} \frac{V_N}{|\dot{R}|} \frac{1}{1 - \frac{t_{std}}{t_{req}}} \quad (24)$$

where  $t_{std}/t_{req}$  would be a specified ratio.

Equations (23) and (24) define the rotation of the thrust vector in the plane containing the range rate and the resultant normal velocity component. The vehicle command angles, however, are referenced to the inertial frame. Therefore, adding the additional angular increments in yaw and pitch as determined from sketch 4 to equations (9) and (10)

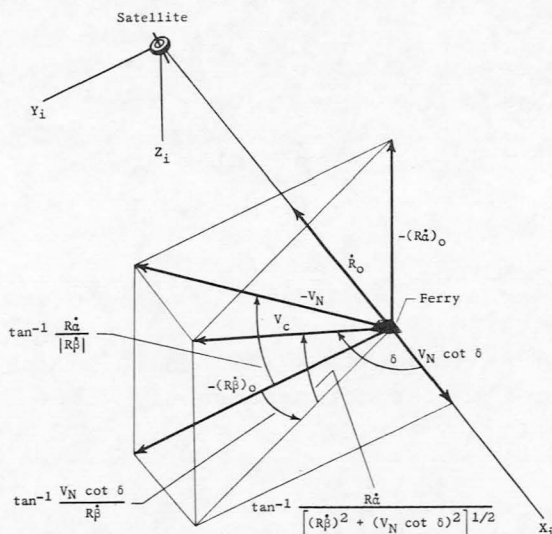

Sketch 4

gives the proper vehicle orientation to align the thrust vector; that is,

$$\psi_c = \Delta\psi - \frac{R\dot{\beta}}{|R\dot{\beta}|} 90^\circ \quad (25)$$

and

$$\theta_c = \Delta\theta - \tan^{-1} \frac{R\dot{\alpha}}{|R\dot{\beta}|} \quad (26)$$

where

$$\Delta\psi = \left( \tan^{-1} \frac{V_N \cot \delta}{R\dot{\beta}} \right)_o \quad (27)$$

and

$$\Delta\theta = \left\{ \tan^{-1} \frac{R\dot{\alpha}}{|R\dot{\beta}|} - \tan^{-1} \frac{R\dot{\alpha}}{\left[ (R\dot{\beta})^2 + (V_N \cot \delta)^2 \right]^{1/2}} \right\}_o \quad (28)$$

#### Predictor Logic for Braking Maneuver

In order to effect a successful rendezvous, the ferry must employ thrust control in such a manner that the range and range rate are reduced to zero simultaneously. The automatic control system accomplishes this objective by using simple prediction techniques to initiate and terminate thrust. The predictor logic for the braking maneuver will first be developed for the control system employing a variable-thrust engine. For this system the thrust is modulated so as to maintain a constant acceleration along the line of sight; that is,

$$\ddot{R} = a = \text{Constant} \quad (29)$$

Integration yields

$$\dot{R} = at + \dot{R}_o \quad (30)$$

and

$$R = \frac{1}{2} at^2 + \dot{R}_o t + R_o \quad (31)$$

Eliminating time from equations (30) and (31) and stipulating that  $R$  and  $\dot{R}$  be reduced to zero simultaneously gives

$$a = \frac{\dot{R}_o^2}{2R_o} \quad (32)$$

In equation (32) the symbol  $a$  represents the acceleration corresponding to the desired thrust level of the engine, and this acceleration would be some value less than full capability. The onboard computer calculates the quantity

$$\frac{\dot{R}^2}{2R}$$

from the instantaneous values of range and range rate. Switching logic, as shown in figure 5(a), is employed in the system to compare continuously the two sides of equation (32) and initiate thrust when an equality is reached. The thrust is then modulated (to account for change in mass and deviations of thrust vector from line of sight) as a function of the error between the required and the existing level of acceleration so as to maintain the equality. Because of the feedback nature of the control, final course corrections can be made during the braking maneuver without affecting the relationship given by equation (32).

The command angles to align the thrust vector for the braking maneuver are given by equations (11) and (12).

For the system utilizing constant thrust, a switching criterion must be used to reduce range and range rate to zero simultaneously and to allow for final course corrections. Such a procedure can be accomplished by controlling the acceleration criterion as given by equation (32) within limits determined by  $A_1$  and  $A_2$ ; that is,

$$A_1 \frac{T}{m_0} = \frac{\dot{R}^2}{2R} \quad (33)$$

and

$$A_2 \frac{T}{m_0} = \frac{\dot{R}^2}{2R} \quad (34)$$

where  $1 > A_1 > A_2$  and  $T/m_0$  is the expected acceleration capability. The two sides of equation (33) are continuously compared, and thrust is initiated when an equality is reached. Likewise, when an equality is reached in equation (34), thrust is terminated.

Figure 5(b) shows a block diagram of the range-rate control system using on-off thrust control.

#### ANALOG SIMULATION STUDY

A simulation study has been conducted on an analog computer to determine the effectiveness of an automatic system employing the

previously developed switching criteria. Relative-motion equations were used in the study, and a six-degree-of-freedom ferry was assumed with a velocity-limited attitude control system. A description of the attitude control system is presented in the appendix.

For this study the terminal phase of rendezvous began at a range of 50 miles and ended at a range of approximately 0.02 mile or 100 feet. At system lock-on the ferry was assumed to be ahead of and moving slower than the satellite (and resulted in a negative relative range rate). Systems employing both modulated and on-off thrust control were investigated. Thrust turn-on and turn-off time delays of 200 milliseconds were used for both types of thrust control.

## RESULTS AND DISCUSSION

### Initial Normal Velocity Correction

Typical results obtained in the analog computer study are presented in figure 6 for the correction of various initial values of  $R\dot{\alpha}$  and  $R\dot{\beta}$ . (The braking phase is not shown.) In order to determine the precision available, the normal velocity components were controlled initially to threshold values of approximately 0.2 ft/sec. In most cases these threshold values would be established by instrumentation errors. At this point the threshold level or dead-zone value was increased to 200 ft/sec to prevent further correction of the residual components.

The simplified command angles (see eqs. (9) and (10)) were used for vehicle orientation, and thrust was initiated when the summation of the errors in yaw and pitch was less than  $2^\circ$ . As shown in figure 6, such a technique resulted in the velocity components  $R\dot{\alpha}$  and  $R\dot{\beta}$  being reduced to the dead-zone value simultaneously when the absolute magnitude of  $R\dot{\alpha}$  was less than or equal to  $R\dot{\beta}$ . However, when the absolute magnitude of  $R\dot{\alpha}$  was on the order of 100 ft/sec greater than  $R\dot{\beta}$ , a very small additional correction was needed to bring  $R\dot{\alpha}$  within the dead zone after  $R\dot{\beta}$  had attained this value. (See fig. 9, for example.) This resulted from the computer error in calculating the arc tangent function for an argument greater than unity. As shown in figure 6(c), the magnitude of the range rate is only slightly altered during this initial correction procedure.

It is also desirable to note in figure 6 the operation of the attitude control system. The pitch and yaw rates for the ferry were limited to about 4 deg/sec. This value represented the maximum rate for linear operation of the system.

### Braking Maneuver

Modulated thrust control.- A typical time history of the automatic control for the entire terminal phase of rendezvous is presented in figure 7 for the system employing modulated thrust control. After the correction of the normal velocity components, the ferry is reoriented and coasts toward the satellite until thrust for braking is initiated. As shown in the figure, the thrust is modulated only during the braking maneuver (as indicated by the trace  $\Delta T = 0$ ). In the study the value of  $\Delta T$  was obtained by integrating the quantity  $a - \frac{\dot{R}^2}{2R}$ . As shown in figure 7, the thrust level at the initiation of braking was 20 percent lower than the required value. The system automatically compensated for this deficiency however. The terminal phase was assumed to end when the range rate had been reduced to a value of about  $-0.5$  ft/sec.

In the computer study, the magnitude of the quantity  $\frac{\dot{R}^2}{2R}$  was found to become quite sensitive to noise at relative ranges less than about 1 mile. Since this quantity was used for thrust modulation purposes, modulation was ceased at a range of 1 mile and the thrust became constant for the remainder of the braking maneuver. With this type of control, the range varied from 100 to 150 feet when the range rate had been reduced to  $-0.5$  ft/sec.

Since the degree of the initial control of the normal velocity components would depend upon the sensitivity of the measuring instruments, various values of  $R\dot{\alpha}$  and  $R\dot{\beta}$  were assumed at the beginning of the braking maneuver. Figure 8 shows the control of a relatively large residual normal velocity component (approximately  $0.15\dot{R}$ ) during the braking maneuver. The simulation of this case was started prior to the braking maneuver to allow sufficient time for the proper vehicle orientation angles to be established. In the actual operation of the system, however, control to provide the proper vehicle orientation for braking would be effected immediately after the initial correction maneuver. As shown, control of the thrust direction in a system using thrust modulation for braking provides good regulation of the normal velocity. The maximum normal velocity component controllable during braking would, in an actual system, be dependent upon the maximum thrust capability of the engine.

On-off thrust control.- Figure 9 shows a time history of the terminal phase of rendezvous for the system utilizing on-off thrust control. The initial control of the normal velocity component is identical to that of the system employing modulated thrust. For braking, however, for the particular case shown thrust is initiated when the predicted acceleration required is one-half of the acceleration capability of the ferry. When the required acceleration has been reduced to two-tenths

of the acceleration capability of the ferry, thrust is terminated. Due to the thrust turn-on time delay and the error involved in calculating the quantity  $\frac{\dot{R}^2}{2R}$  at very small ranges (20 to 30 feet), the final value of the range rate was approximately 10 ft/sec when the range was reduced to zero. Consequently, it was found necessary in the computer study to incorporate an overriding switching criterion which initiated thrust at a range of 250 feet and terminated thrust when the range rate had been reduced to approximately -0.5 ft/sec. With this type of control, the range varied from 100 to 130 feet when the range rate had been reduced to -0.5 ft/sec.

The variation of range rate with range for variations in the acceleration switching limits is shown in figure 10. Successful rendezvous is achieved for all cases shown. Evident from the figure, however, is the fact that the number of times that the thrust is turned on and off can be greatly reduced by increasing the difference between the switching limits.

The control of a large residual normal velocity component (approximately 0.15R) during the braking maneuver for a system employing on-off thrust control is shown in figure 11. The maximum normal velocity component controllable would be dependent upon the thrust capability of the engine and the upper acceleration limit at which thrust is initiated.

#### Energy-Management Technique

Figure 12 shows a typical time history of the terminal phase of rendezvous for control based upon the available fuel supply. For the case shown ( $\frac{V_N}{R} = 0.223$ ), the velocity increment available for the rendezvous maneuver was assumed to be 1,100 ft/sec or 89.6 percent of the standard value. Comparing the time required to rendezvous based upon the energy-management technique shown in figure 12 with the time required by using the basic technique shown in figure 9 gives a  $t_{std}/t_{req}$  ratio of 0.75. This value compares favorably with the predicted  $t_{std}/t_{req}$  ratio of 0.78 as determined from figure 4. The velocity increment required to effect rendezvous was 1 percent greater than the amount specified at lock-on. Very close control, therefore, was achieved by the system.

#### CONCLUSIONS

The results of the present study of an automatic system for control of the terminal phase of satellite rendezvous lead to the following conclusions:

1. The system employing the developed switching and thrust orientation criteria can effectively control the terminal phase of satellite rendezvous over a wide range of initial "lock-on" conditions and control-system requirements.

2. The addition to the basic system of switching criteria based upon the available fuel insures not only a very efficient utilization of the available fuel but also minimizes the time in which rendezvous can be effected.

3. The vehicle acceleration requirements can be satisfied by a single engine with either a modulated or on-off thrust capability.

Langley Research Center,  
National Aeronautics and Space Administration,  
Langley Air Force Base, Va., October 10, 1961.

## APPENDIX

## ATTITUDE CONTROL SYSTEM

The vehicle attitude control system, although simple in nature, provides good control of the attitude over a wide range of command attitudes. A block diagram of the system is shown in sketch 5. The system

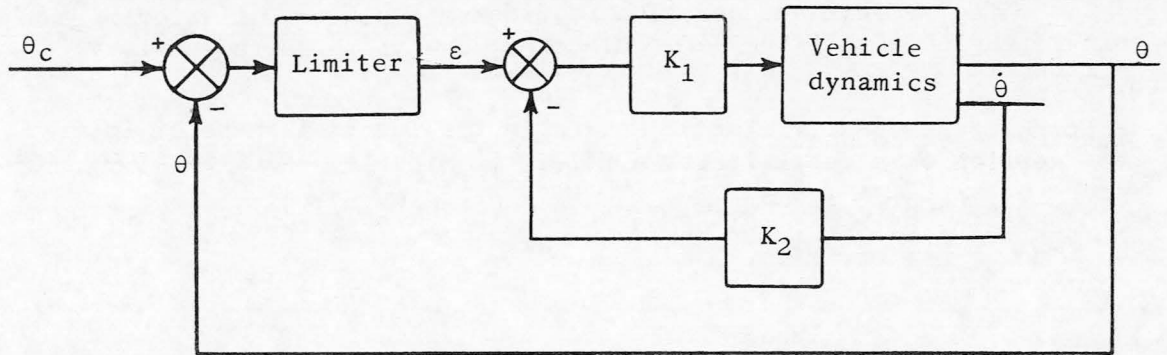

Sketch 5

is effectively a velocity-limited attitude controller. The inner loop provides damping by use of rate feedback and, in addition, provides a canceling signal for the limited attitude error signal. Thus when a large attitude error is present, control torque will be provided only until an established rate is reached. After this point the vehicle will coast at constant rate until the attitude error is reduced below the limiting value. The rate feedback provides effective damping to stabilize about the null error position.

The gain  $K_1$  was adjusted so that the maximum acceleration was  $0.917 \text{ deg/sec}^2/\text{deg}$ ,  $K_2$  was adjusted so that the maximum acceleration was  $1.461 \text{ deg/sec}^2/\text{deg/sec}$ , and the limiter was set at  $|\epsilon| \leq 5^\circ$ .

The system provided excellent control with no overshoot as illustrated by the attitude change shown in figure 6.

## REFERENCES

1. Carney, Terrance M.: An Automatic Terminal Guidance System for Rendezvous With a Satellite. NASA TN D-923, 1961.
2. Brissenden, Roy F., Burton, Bert B., Foudriat, Edwin C., and Whitten, James B.: Analog Simulation of a Pilot-Controlled Rendezvous. NASA TN D-747, 1961.
3. Nason, Martin L.: Terminal Guidance and Rocket Fuel Requirements for Satellites. [Preprint 777-59.] Presented at Am. Rocket Soc. Controllable Satellite Conf., MIT, Apr. 30-May 1, 1959.
4. Hord, Richard A.: Relative Motion in the Terminal Phase of Interception of a Satellite or a Ballistic Missile. NACA TN 4399, 1958.
5. Goldstein, Herbert: Classical Mechanics. Addison-Wesley Pub. Co., Inc. (Reading, Mass.), c.1959.

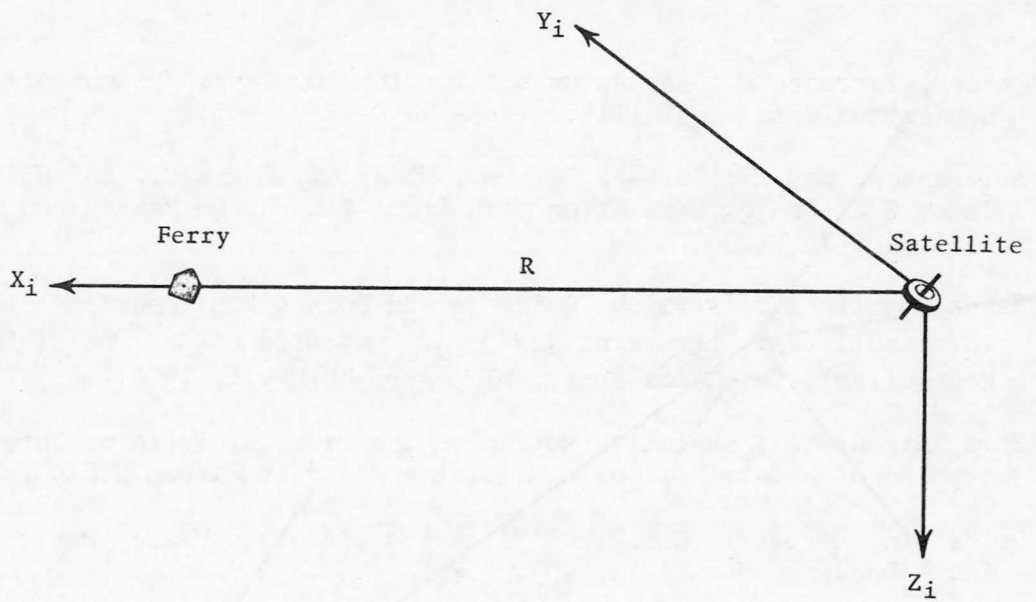

(a) Initial position of ferry.

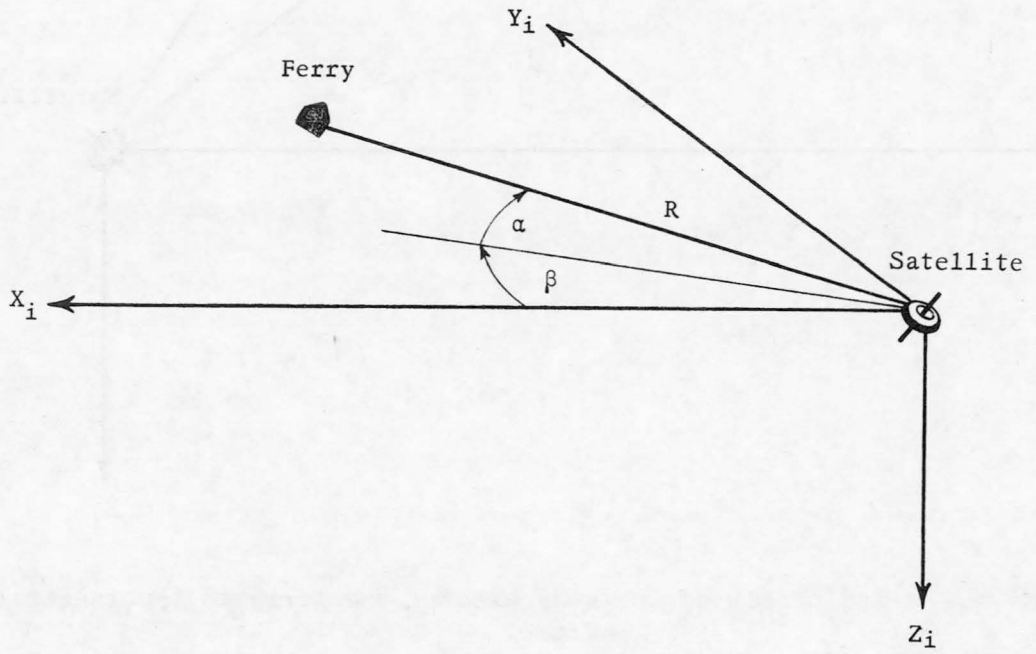

(b) Future position of ferry.

Figure 1.- Ferry position relative to satellite in an inertial frame.

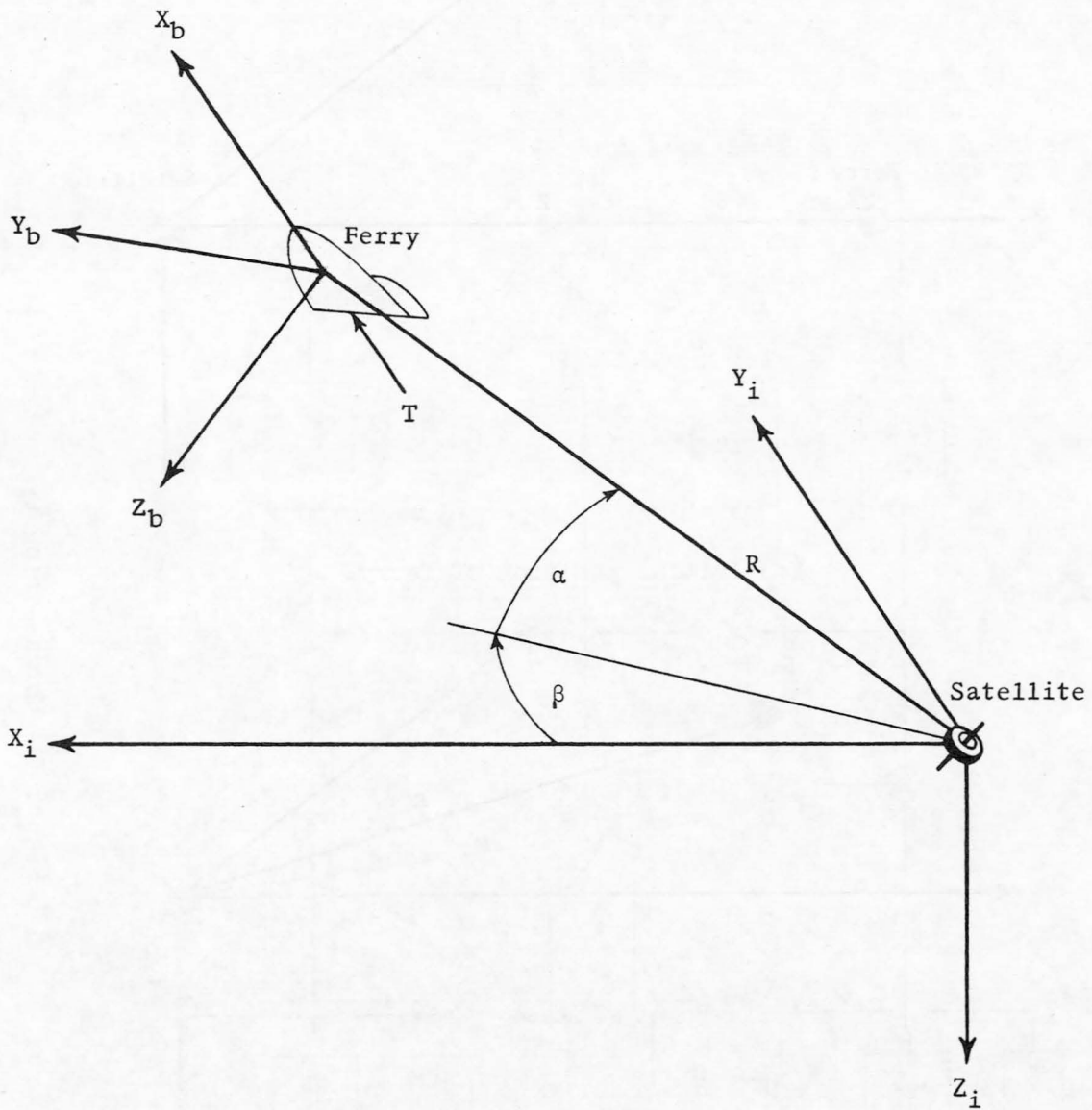

Figure 2.- Relationship of the body axes of the ferry to the inertial frame.

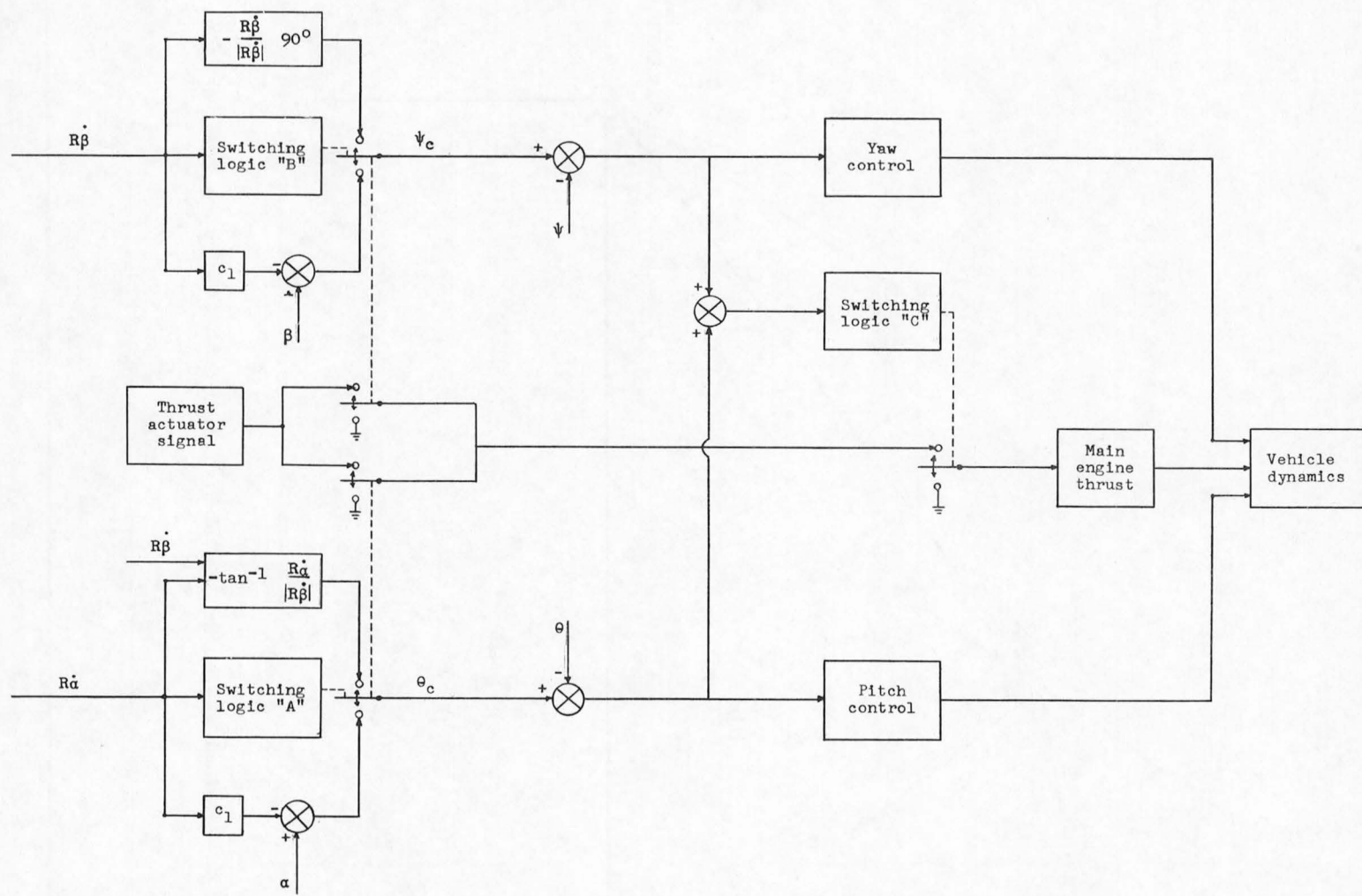

Figure 3.- Normal-velocity control.

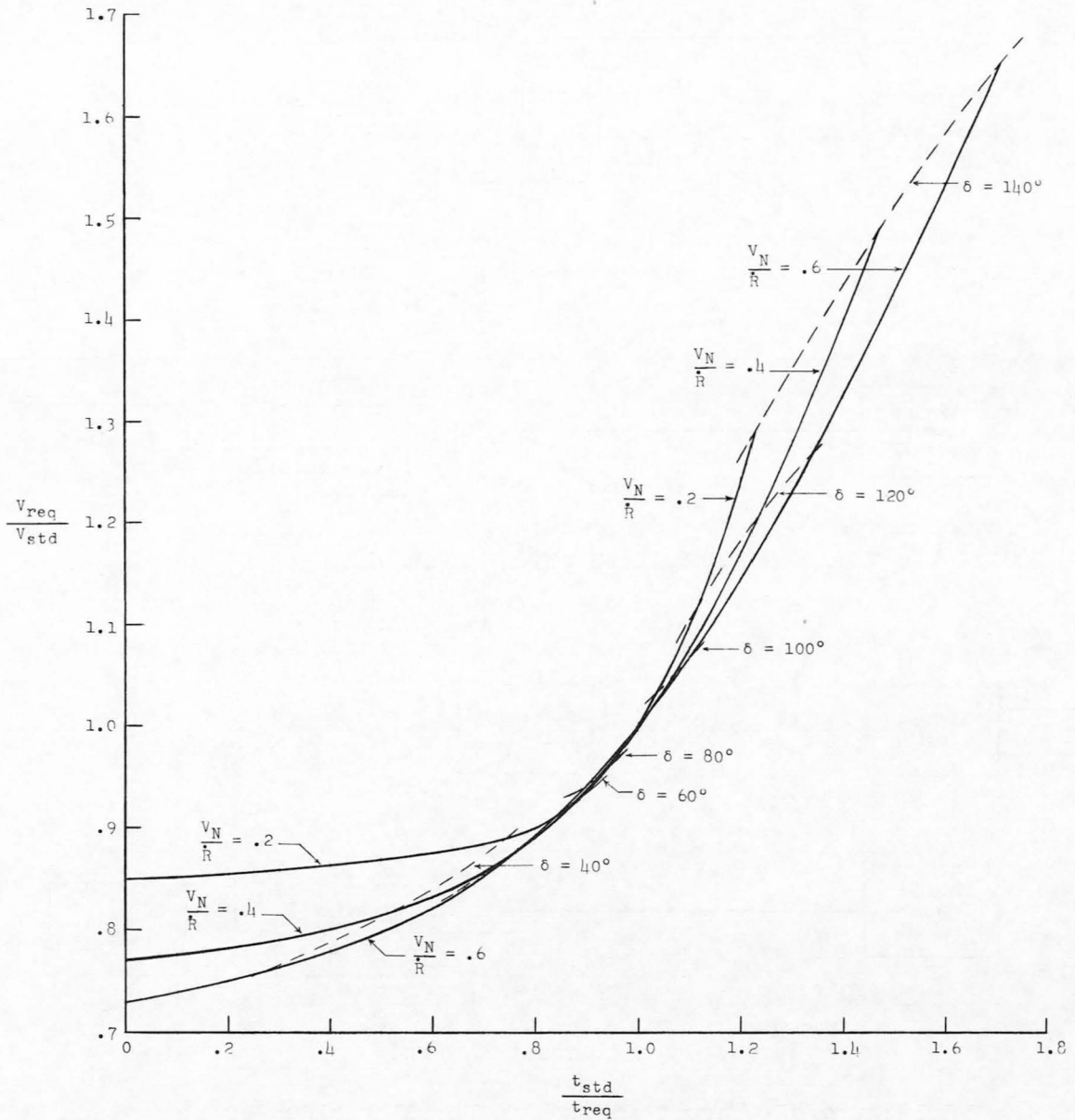
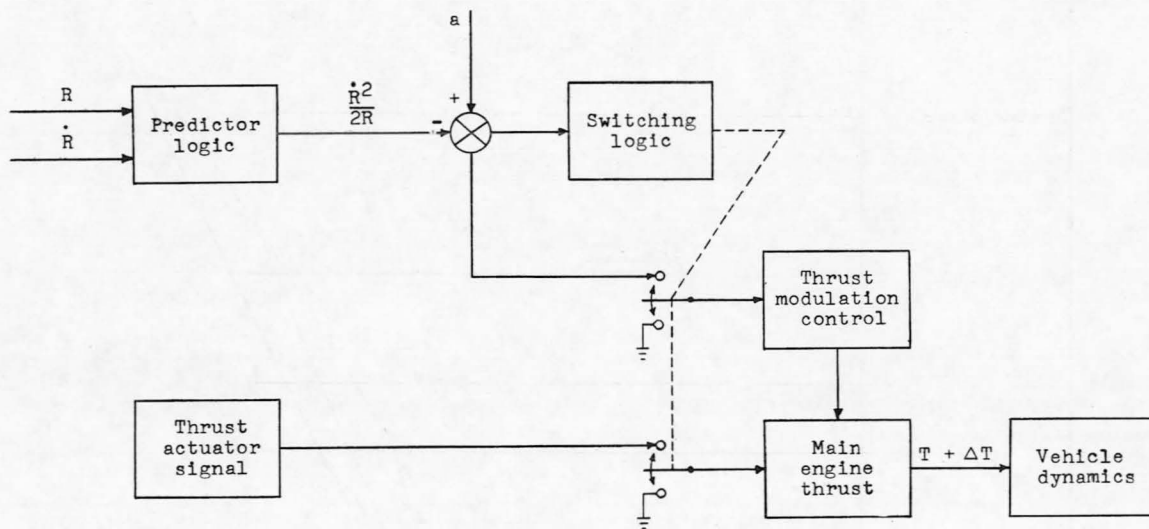
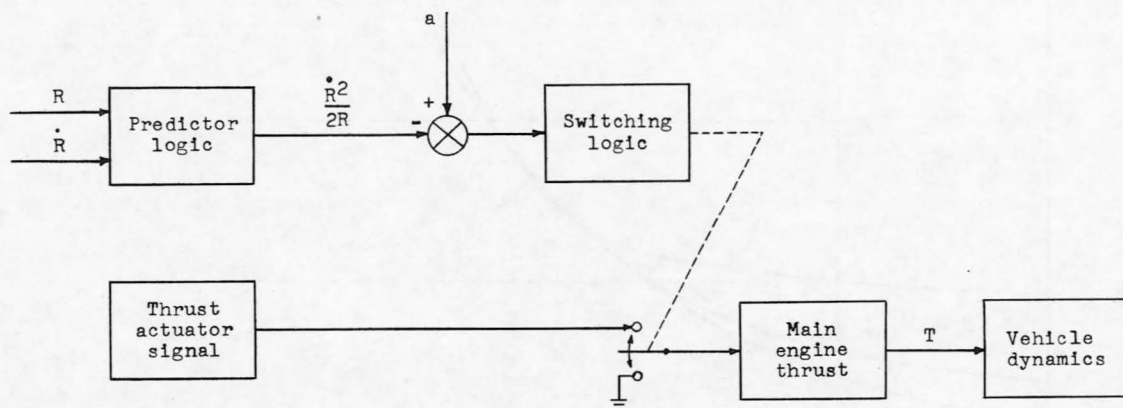

Figure 4.- Relationship between velocity and time requirements for the terminal phase of rendezvous.



(a) Modulated thrust control.



(b) On-off thrust control.

Figure 5.- Thrust control for braking maneuver.

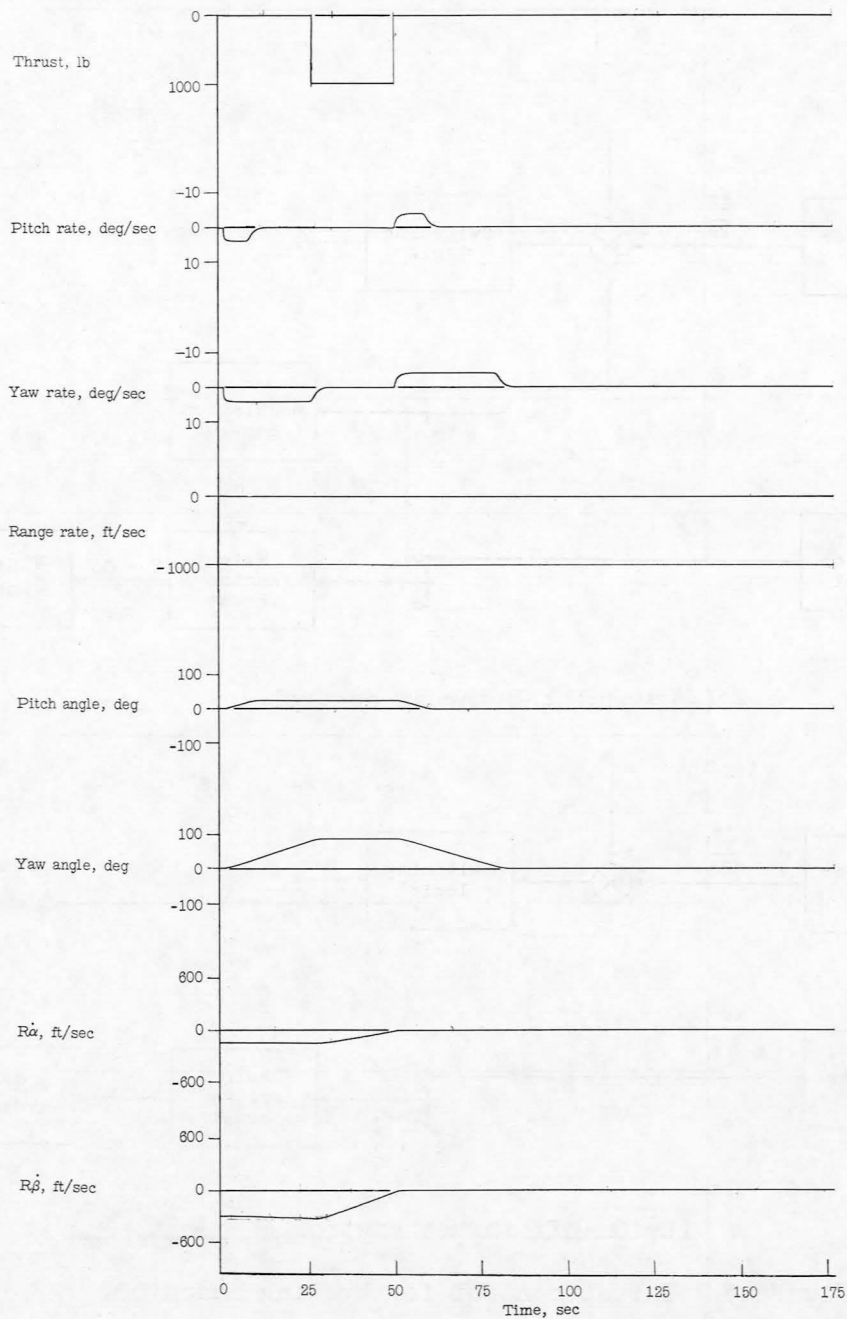

(a)  $(R\dot{\alpha})_0 = -150 \text{ ft/sec}$ ;  $(R\dot{\beta})_0 = -300 \text{ ft/sec}$ .

Figure 6.- Time history of the initial control of the normal velocity components  $R\dot{\alpha}$  and  $R\dot{\beta}$ .

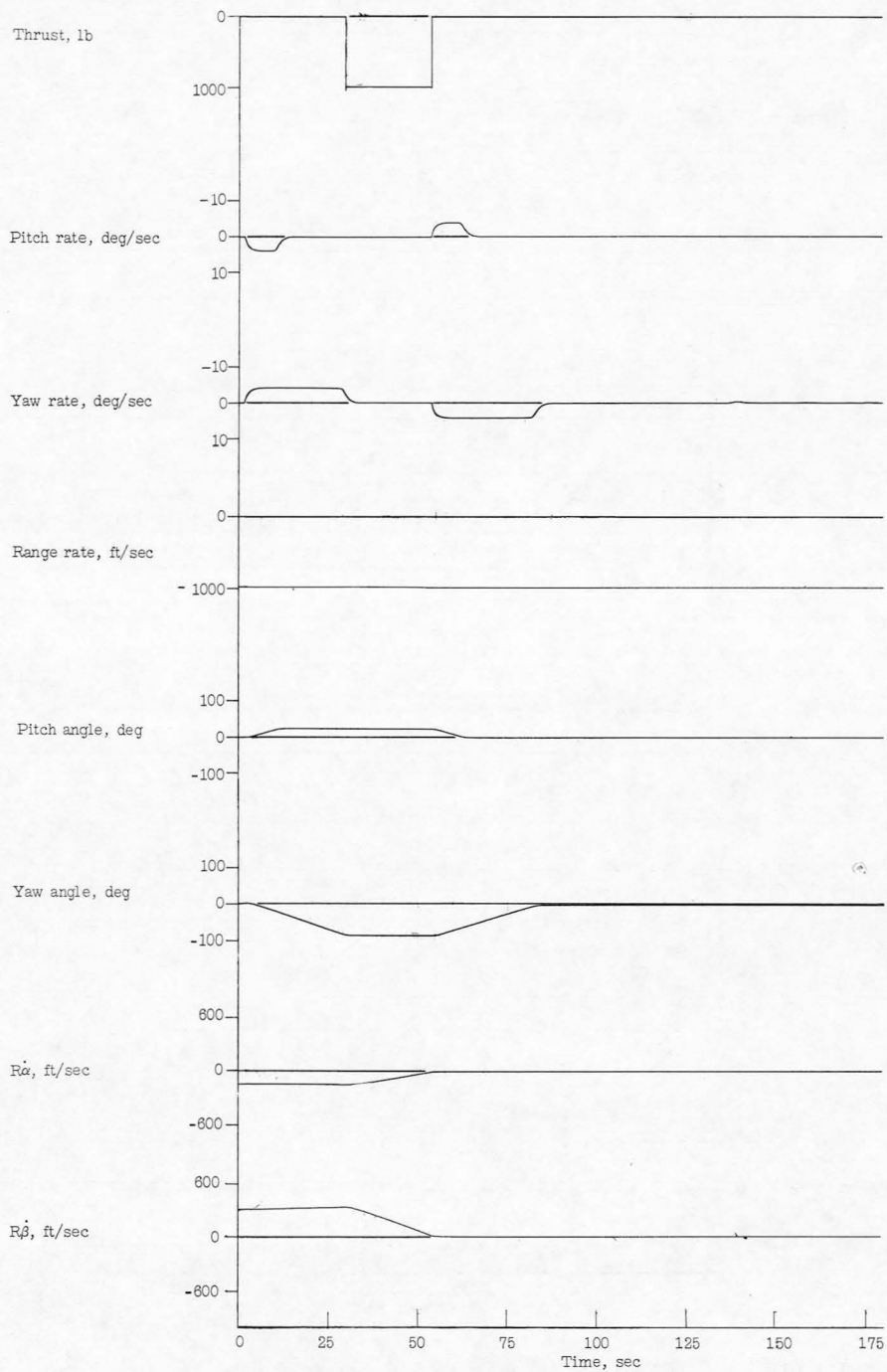

(b)  $(R\dot{\alpha})_0 = -150$  ft/sec;  $(R\dot{\beta})_0 = 300$  ft/sec.

Figure 6.- Continued.

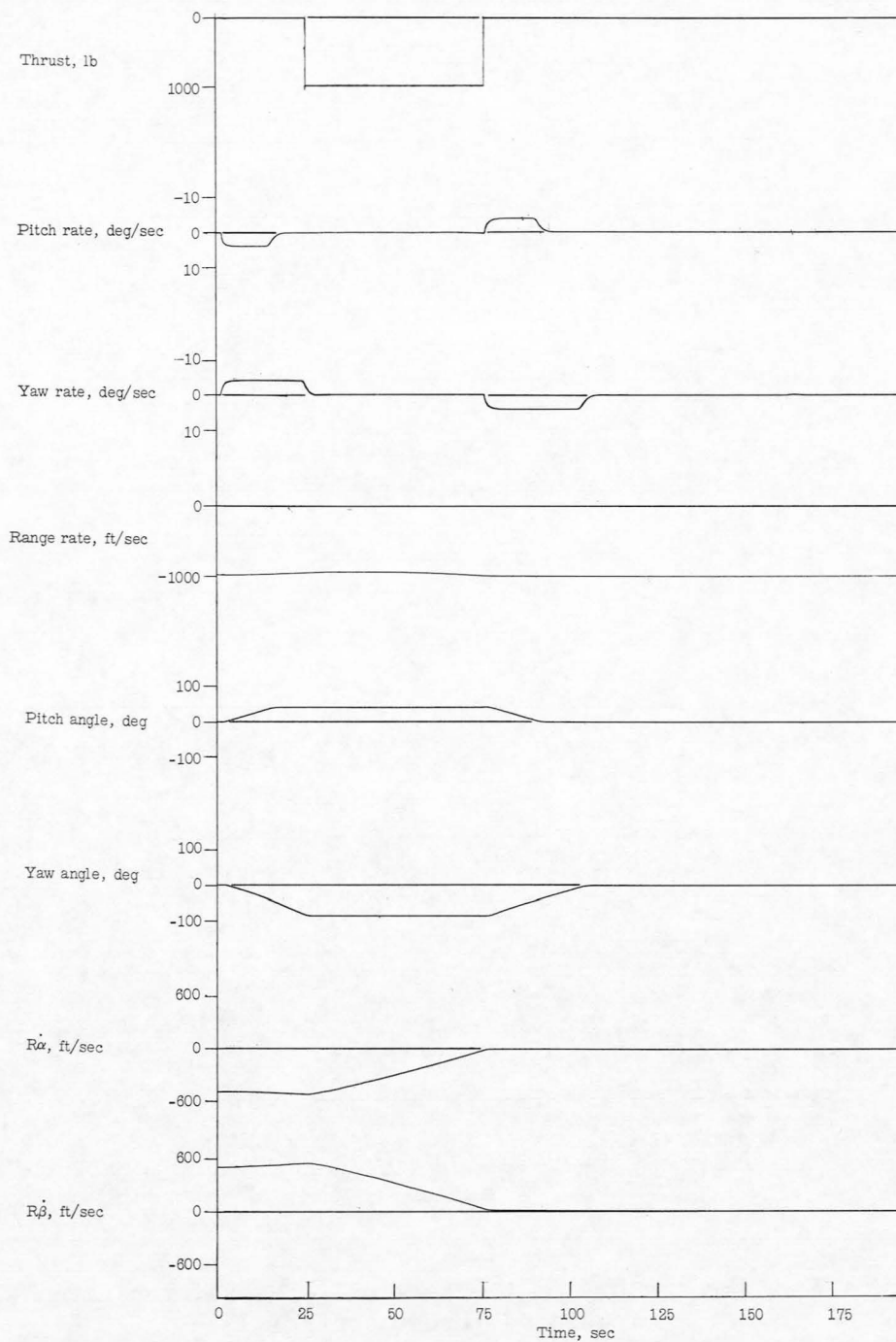

(c)  $(\dot{R}_\alpha)_0 = 500 \text{ ft/sec}$ ;  $(\dot{R}_\beta)_0 = 500 \text{ ft/sec}$ .

Figure 6.- Concluded.

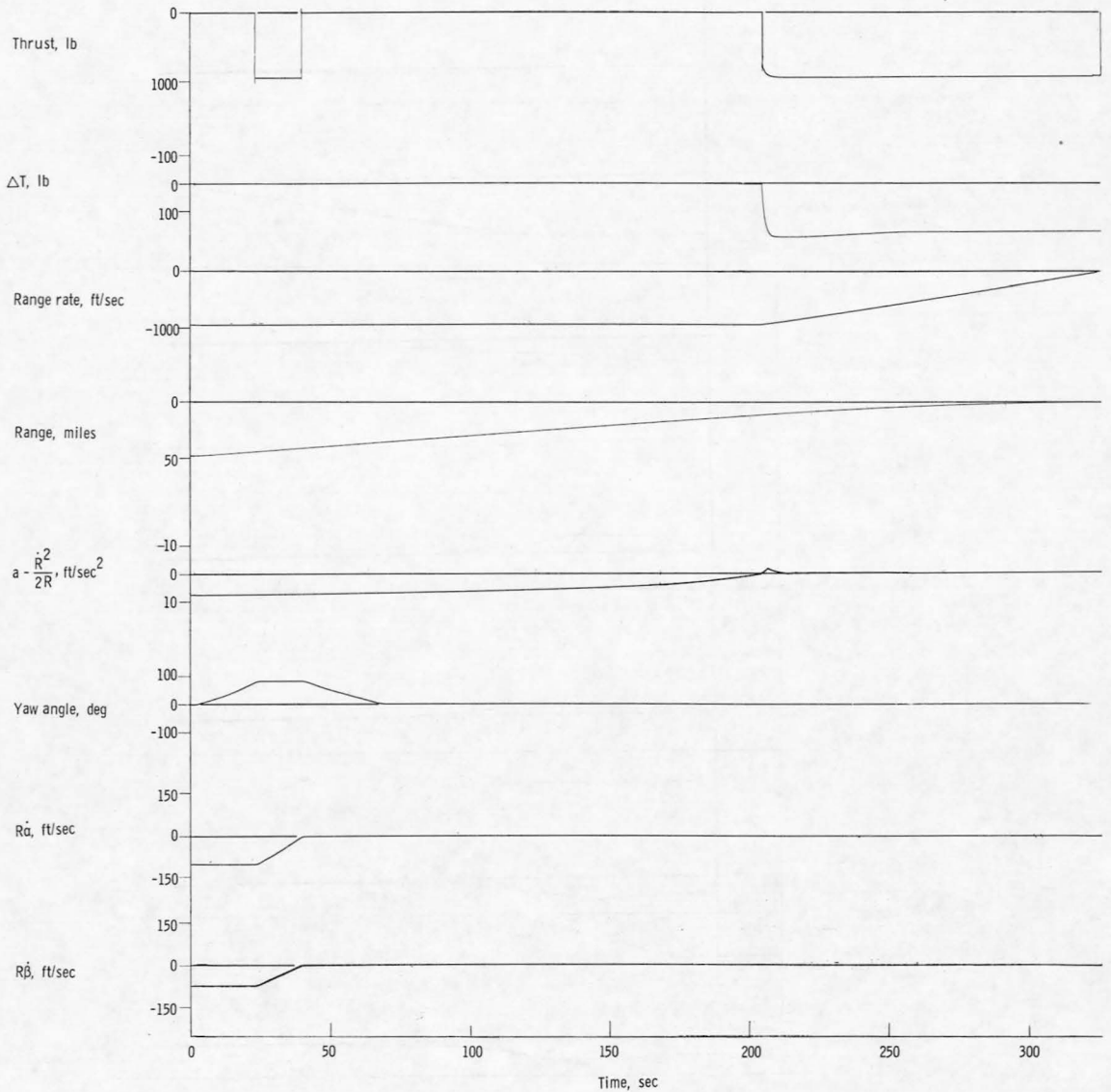

Figure 7.- Time history of the terminal phase of rendezvous for modulated thrust control.

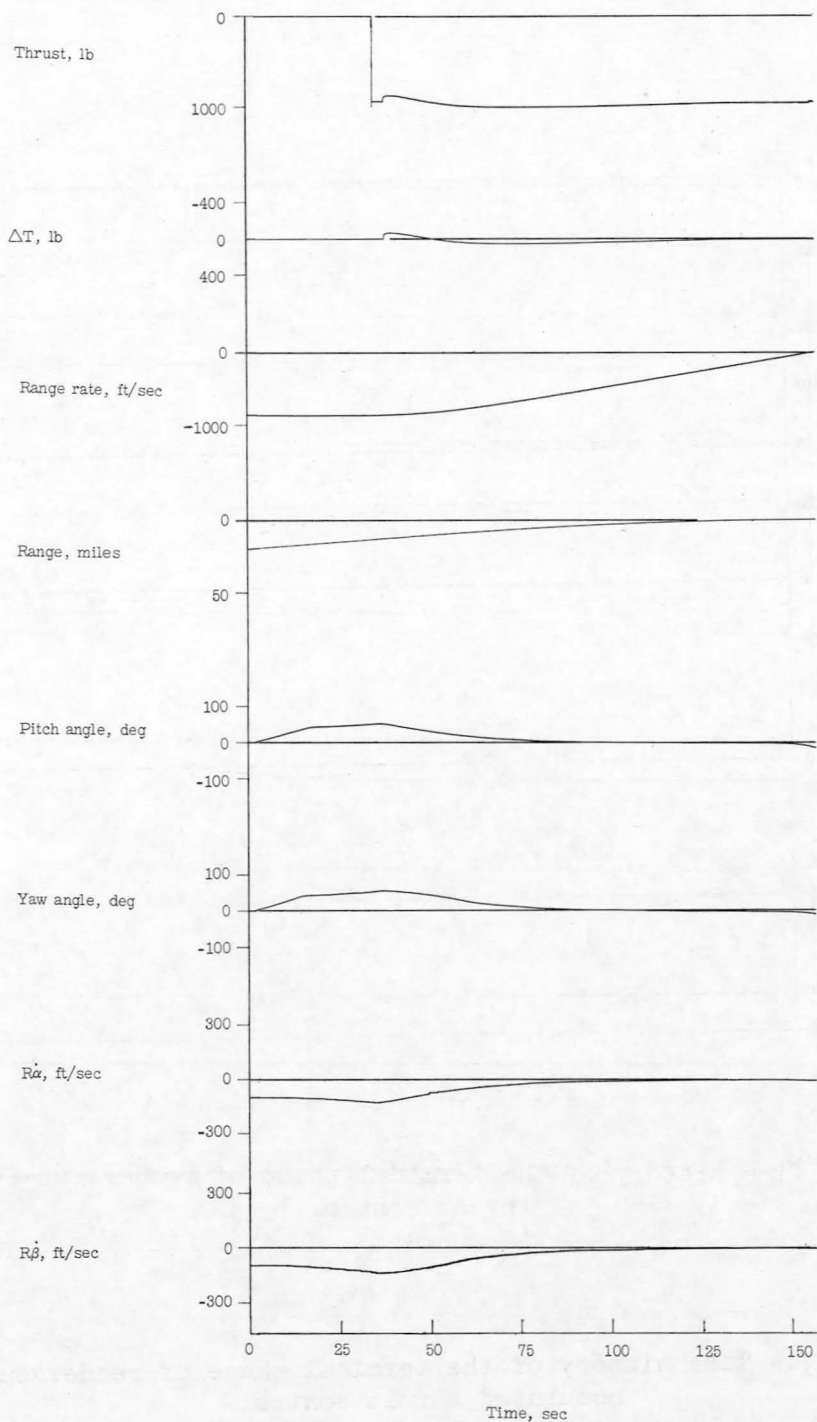

Figure 8.- Time history of the control of residual normal velocity components during braking for system employing modulated thrust control.

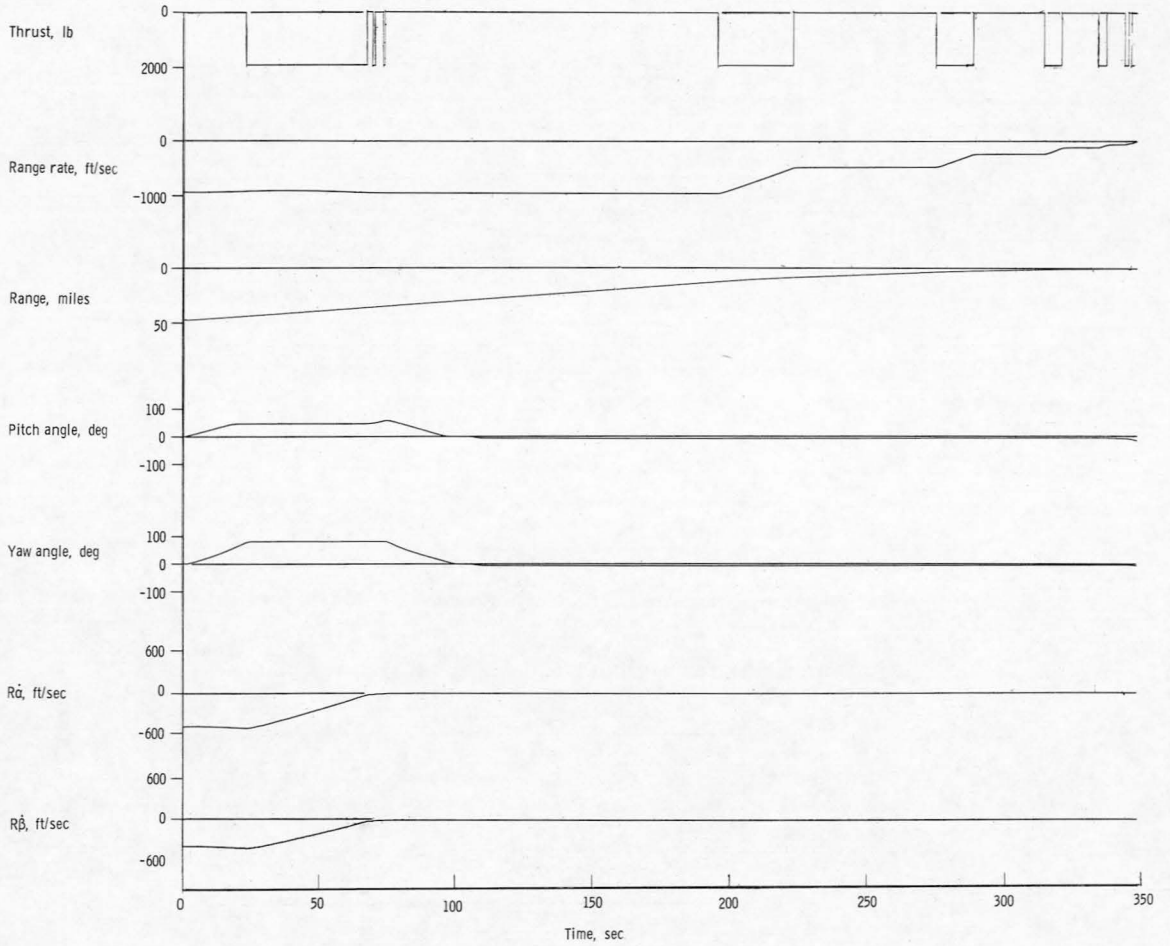
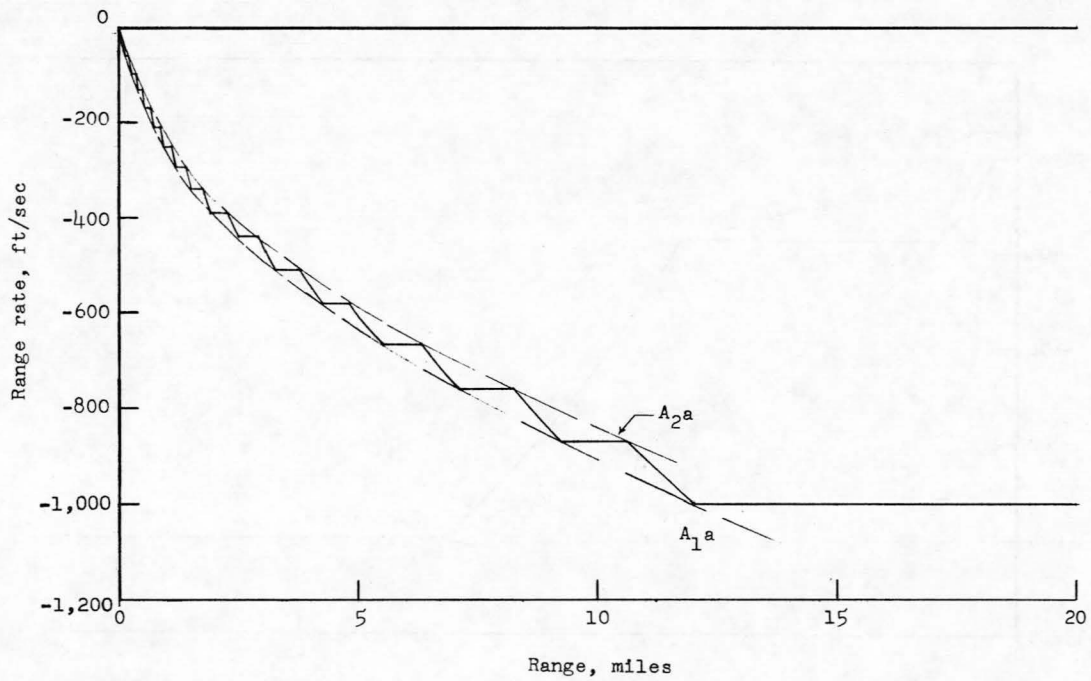
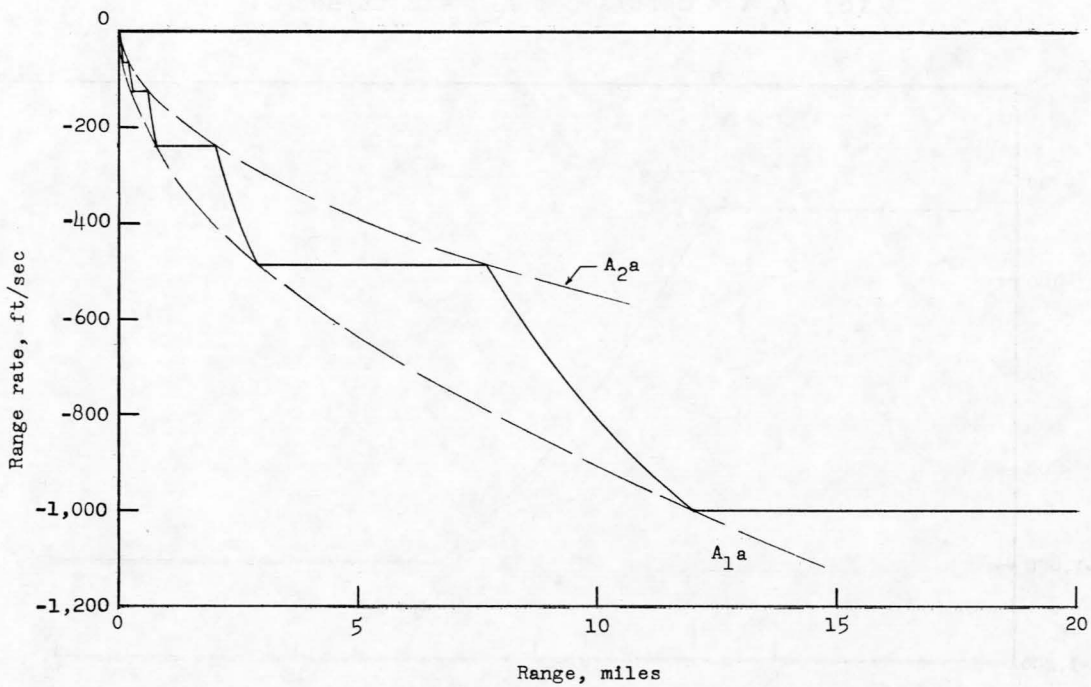

Figure 9.- Time history of the terminal phase of rendezvous for on-off thrust control.



(a)  $A_{1a} = 8 \text{ ft/sec}^2$ ;  $A_{2a} = 7 \text{ ft/sec}^2$ .



(b)  $A_{1a} = 8 \text{ ft/sec}^2$ ;  $A_{2a} = 3 \text{ ft/sec}^2$ .

Figure 10.- Variation of range rate with range for on-off thrust control during braking maneuver.

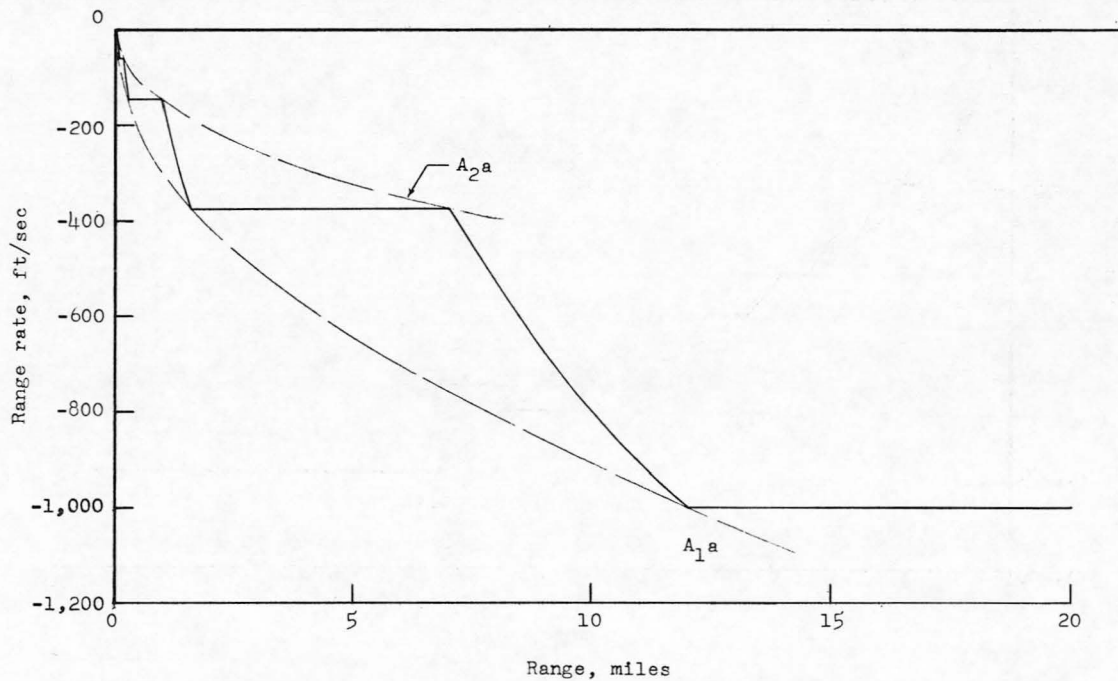

(c)  $A_1a = 8 \text{ ft/sec}^2$ ;  $A_2a = 2 \text{ ft/sec}^2$ .

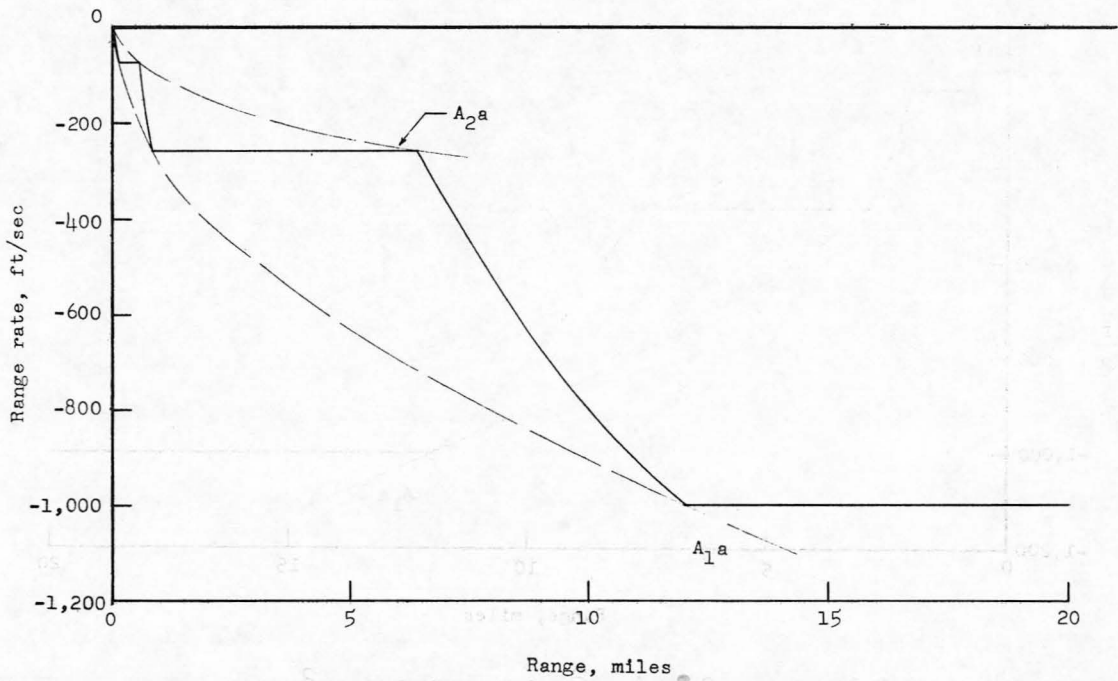

(d)  $A_1a = 8 \text{ ft/sec}^2$ ;  $A_2a = 1 \text{ ft/sec}^2$ .

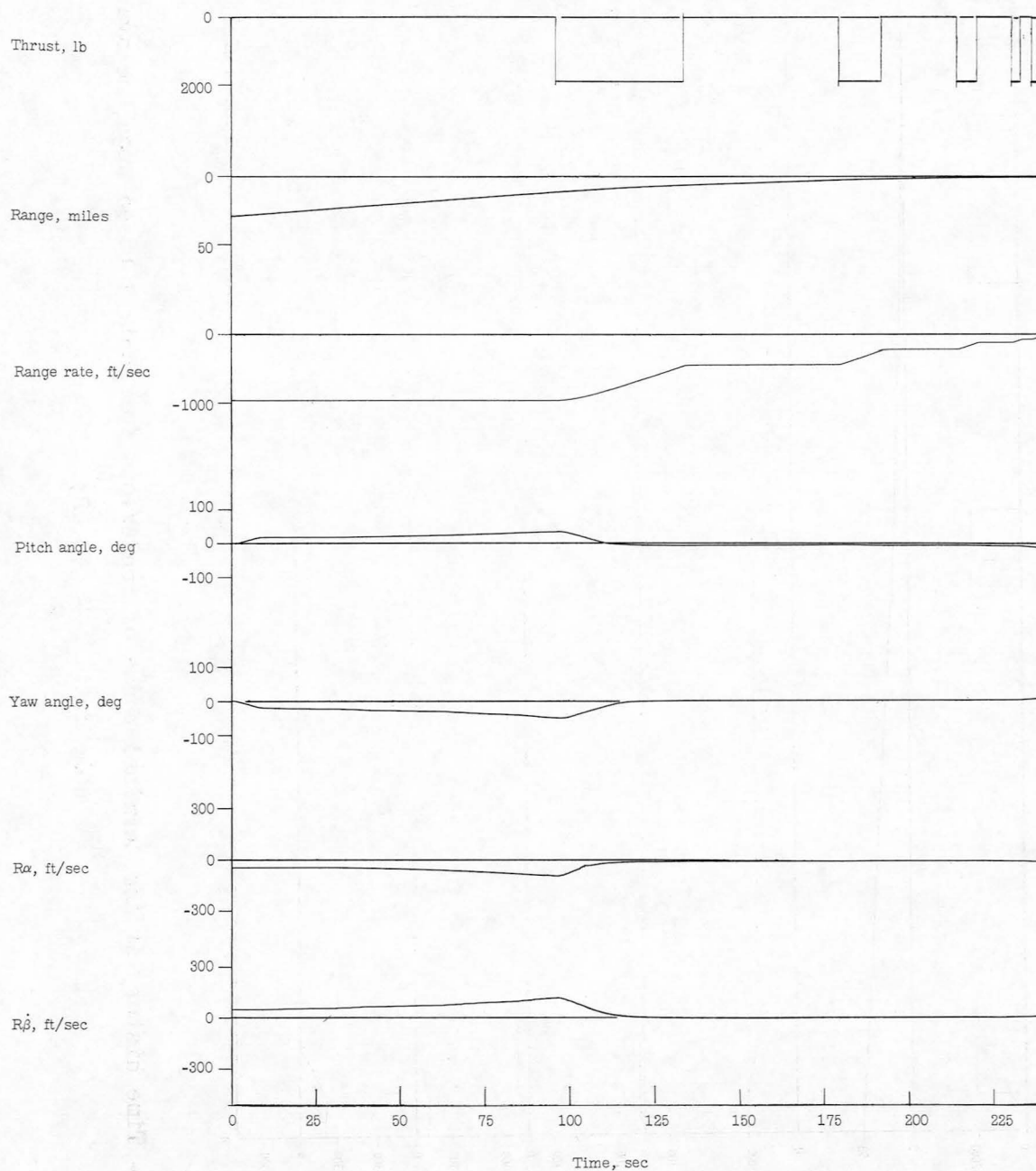

Figure 11.- Time history of the control of residual normal velocity components during braking for system employing on-off thrust control.

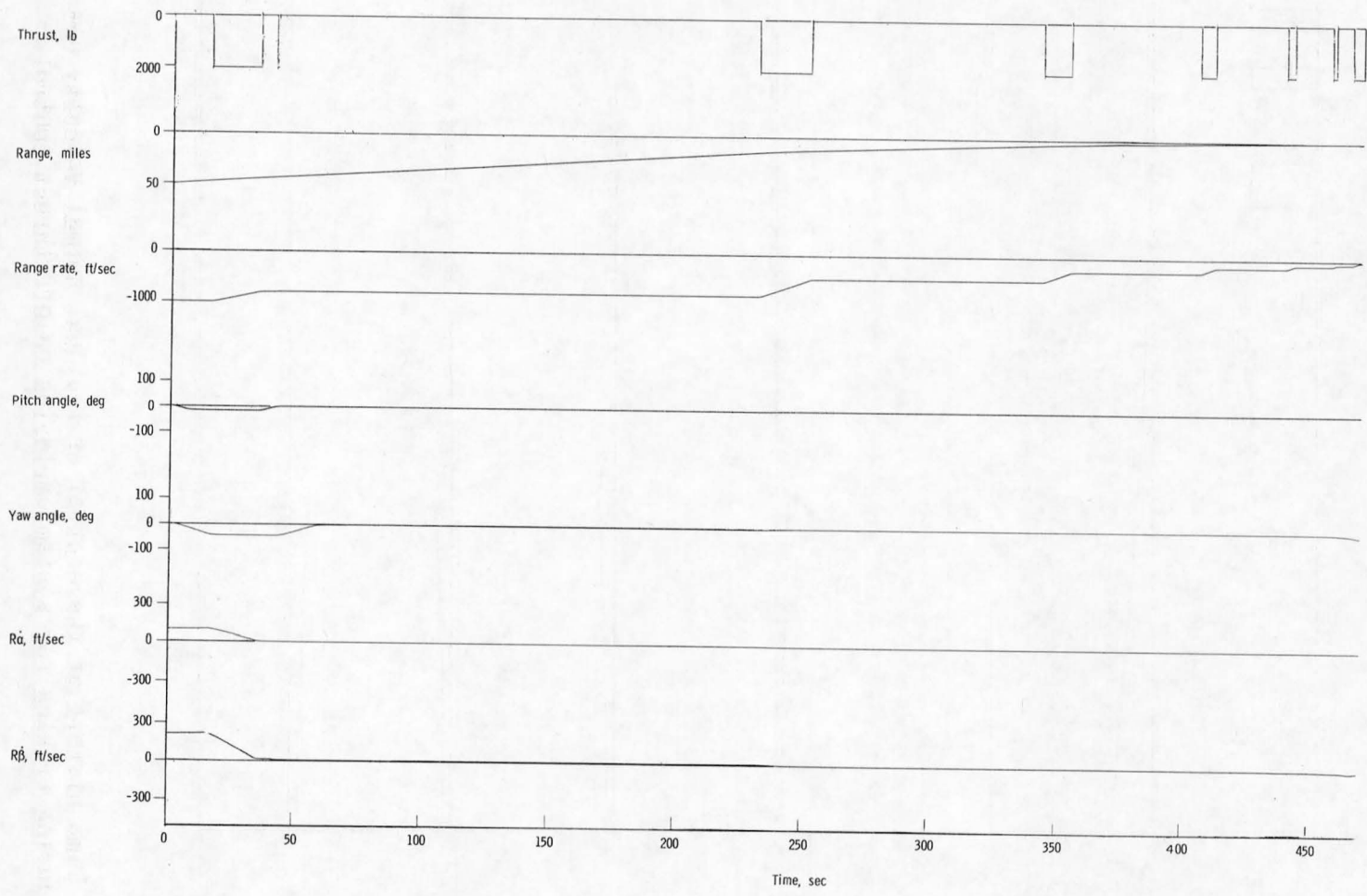

Figure 12.- Time history of the terminal phase of rendezvous for control based upon the available fuel.  $\frac{V_N}{R} = 0.223$ .



