

## *The Making of a MAD MUTT*

### *The X-56A Multi-Utility Technology Testbed Aircraft*



**Edward L. Burnett**  
*Lockheed Martin*

**Jacob Schaefer**  
**NASA**



- **Lockheed Slides removed (approved through their process)**

## X-56A Multi-Utility Technology Test-bed

### • Timeline:

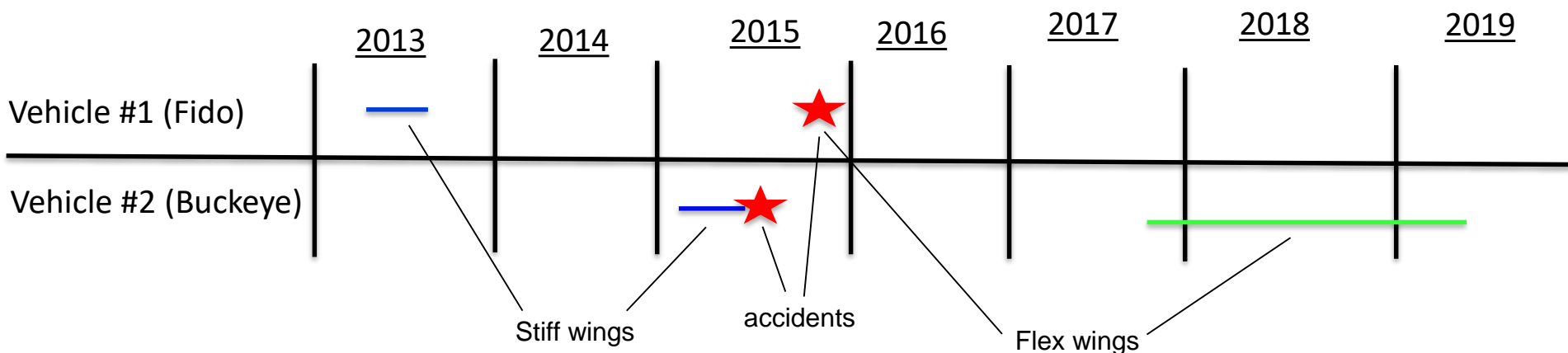

- Vehicle #1
  - 8 stiff wings flights in 2013
  - Crashed on first takeoff with flexible wings (loss of vehicle)
- Vehicle #2
  - 8 flights with stiff wings in 2015, crashed on landing (damaged but repairable)
  - First flex wing flight in 2017, flight test ongoing, currently at 37 flights

- **Stiff Wing Flight Test**

Final video removed for transfer

## *X-56A Multi-Utility Technology Test-bed*

- **Went on to then complete 8 more flights with the stiff wings on vehicle #2 to clear the flight envelope**
  
- **Then two accidents occurred**
  - **Vehicle #2 had an unstable oscillation upon landing on flight #8.**
  - **Vehicle #1 crashed on takeoff for it's first attempted flight with the flexible wings.**
  
  - **Digging into the physics, solutions were found.**
  
  - **Eventually solved takeoff and landing and went on to flutter testing.**

## X-56A Multi-Utility Technology Test-bed

- Occurred on last landing (flight #8) with stiff wings on vehicle #2
- Nominal touchdown
- Aircraft then entered into a pitch bouncing oscillation that was slowly growing.
- Eventually grew large enough to crumple the nose gear, skidded to a stop.

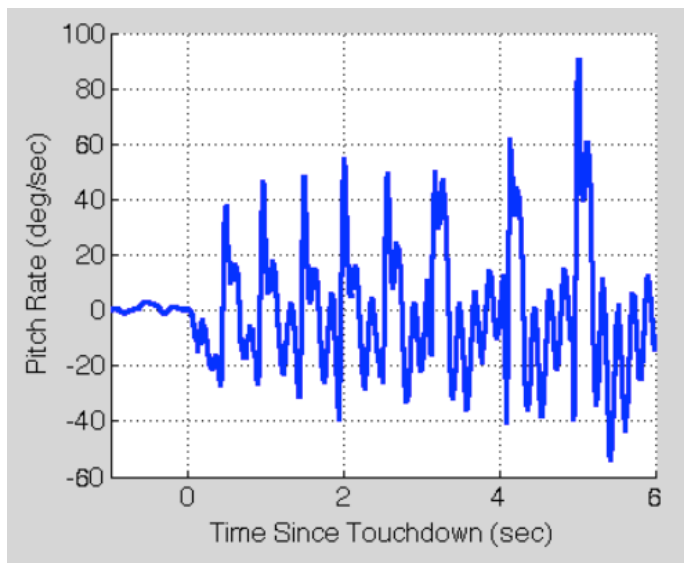

## X-56A Multi-Utility Technology Test-bed

- Landing gears purpose is to absorb shock loads from ground impact.
- Due to the location of the center of gravity, aero/control is pitch unstable when rotating about the main gear, however with nose gear damping it becomes stable.
- On this flight it was found the nose gear jammed and provided no damping.
- In the design of the nose strut tube, the vertical forces were accounted for however the forces from the tire spinning up were not which caused a large for-aft force which after repeated landings, deformed the tube. Bowed the tube aft, resulting in it jamming in the bushing.

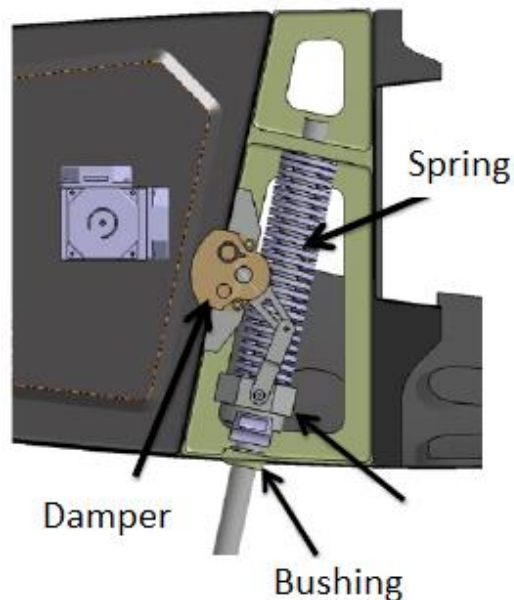

## *X-56A Multi-Utility Technology Test-bed*

- **Simply overlooked what was assumed to be small forces, however for our scale aircraft and relatively heavy tires, the spin up forces were found to be significant.**
- **Also the flexible wings (even for stiff wings) results in more energy going into aircraft structure rather than landing gear upon impact.**
  - Like two springs stacked on top of each other, when the spring constant of the structure is lowered and approaches that of the gear, less energy goes into the gear and more into the structure.
  - Usually assumed most of the energy goes into the gear. For the flexible wings this is not the case.
  - Aircraft structure has nearly zero damping (<3%) so energy remains in the system much longer thus making the problem even worse. Requires more damping.



## *X-56A Multi-Utility Technology Test-bed*

- **Better mechanical design**
  - Thicker strut tube, spherical bushings, better dampers (specially tuned mountain bike dampers)
- **Better control software**
  - Once wheels touch down, software kick into a special mode that uses control surfaces to add damping to bouncing mode using accelerometer feedback.
  - Designed specifically for flexible wings to get energy out of the pitch oscillation and structure.
- **Reduce speed faster**
  - Instability is driven by dynamic pressure so getting it slowed faster would prevent oscillation from growing.
  - Improved brakes to get maximum braking, pushing the limits to where the wheels are just short of locking up
  - Attempted a drag parachute however stability and shock loads were of issue and prevented use.

## *X-56A Multi-Utility Technology Test-bed*

- **First attempt at flight with the flexible wings (vehicle #1)**
- **At takeoff rotation, the vehicle pitched up at rates higher than expected, aircraft stalled and crashed back into the ground.**



## X-56A Multi-Utility Technology Test-bed

- Rotation can be thought of as building up of angle of attack and transferring the weight of the airplane from the main gear to an aerodynamic lift force on the wing.

Statically Stable

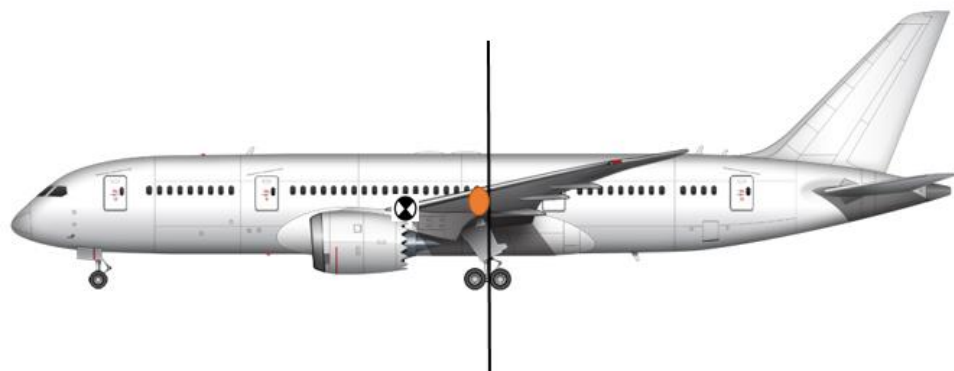

Statically Unstable

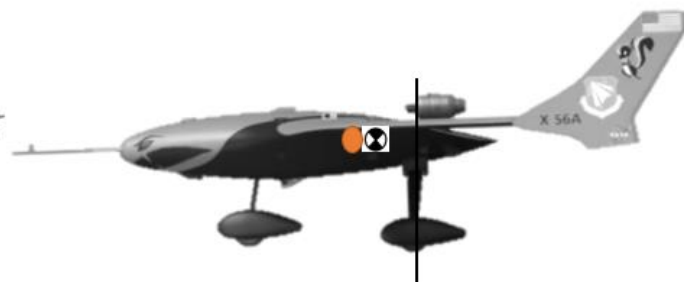

- For statically stable aircraft (ac aft of cg), the lift force is nearly collocated with the main gear resulting in no moment change.
- For statically unstable aircraft (such as the X-56), the lift force comes in far forward of the main gear, resulting in a positive pitch acceleration during rotation. Thus once rotation begins, it accelerates until the vehicle is free to rotate about the cg.

## X-56A Multi-Utility Technology Test-bed

- During stiff wing the rotations were violent but survivable.
- There were two differences between the takeoffs for the stiff wing and the flex wing.
  - Control system was lower gain and thus reacted slower
  - Wings deformed significantly from unloaded to fully loaded state
    - Deformation itself resulted in further pitch up moment.

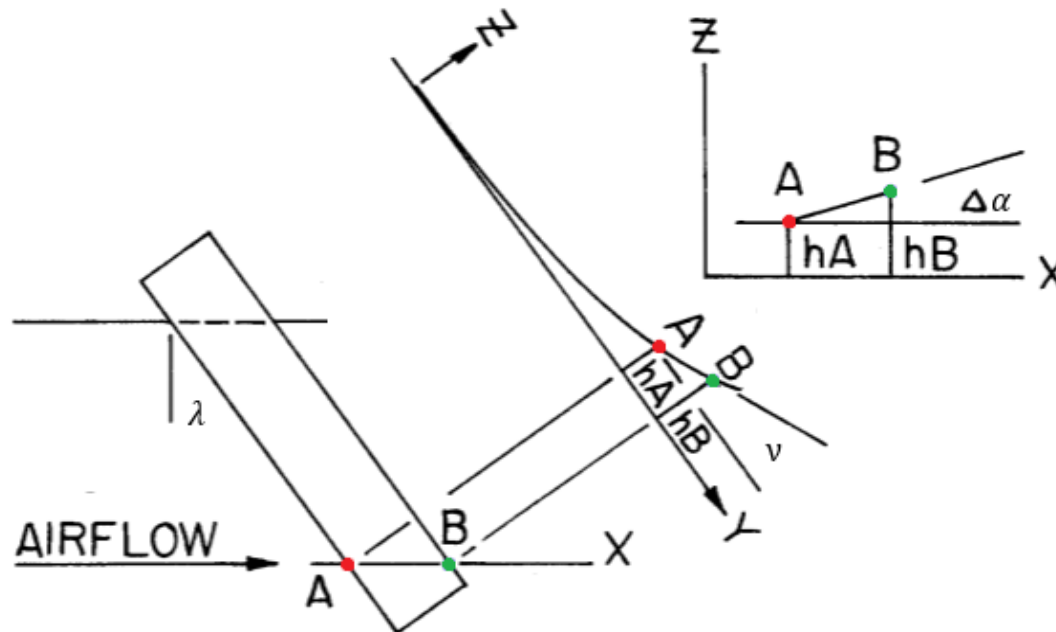

## *X-56A Multi-Utility Technology Test-bed*

- **Landing gear geometry changes to reduce increased pitch moment during rotation**
- **Reduce both the moment arm and the force**
  1. **Push main gear as close to aerodynamic center as possible.**
    - Reduces the moment arm length for the force transferring from main gear to aerodynamic center.
  2. **Increase angle of attack on the ground**
    - Reduces the amount of force that transfers during rotation. Get some lift prior to rotation. Essentially start bending the wings up and then rotate less to get the final lift needed for flight.
    - Essentially like a B-52, which has a bomb bay near the aerodynamic center and thus the main gear are far aft (same problem) so it sits at high angle of attack on the ground so it doesn't have to rotate. It just reaches flight lift at a certain speed on the ground and just lifts off the ground without rotating.

*X-56A Multi-Utility Technology Test-bed*

- **First flex wing flight (vehicle #2)**

Final video removed for transfer

## *X-56A Multi-Utility Technology Test-bed*

- **Increased airspeed envelope in 10 kt increments until within 10 knots of expected flutter and then took smaller steps of 5 knots.**
- **Each new airspeed required several flights**
  - **Conducted raps: High frequency pulses to the control surfaces to excite structural modes. Then evaluate the damping of the modes with the control system active. If  $>0.04$  damping, continue on, else retune control laws.**
  - **Checked control margins: all control law feedback loop margins were evaluated by applying multi-sine frequency inputs and then evaluating the loop transfer function. If  $>3\text{dB}$  of gain margin and 30 deg phase margin, continue on.**

- In flight measurements of frequency and damping of modes contributing to flutter.

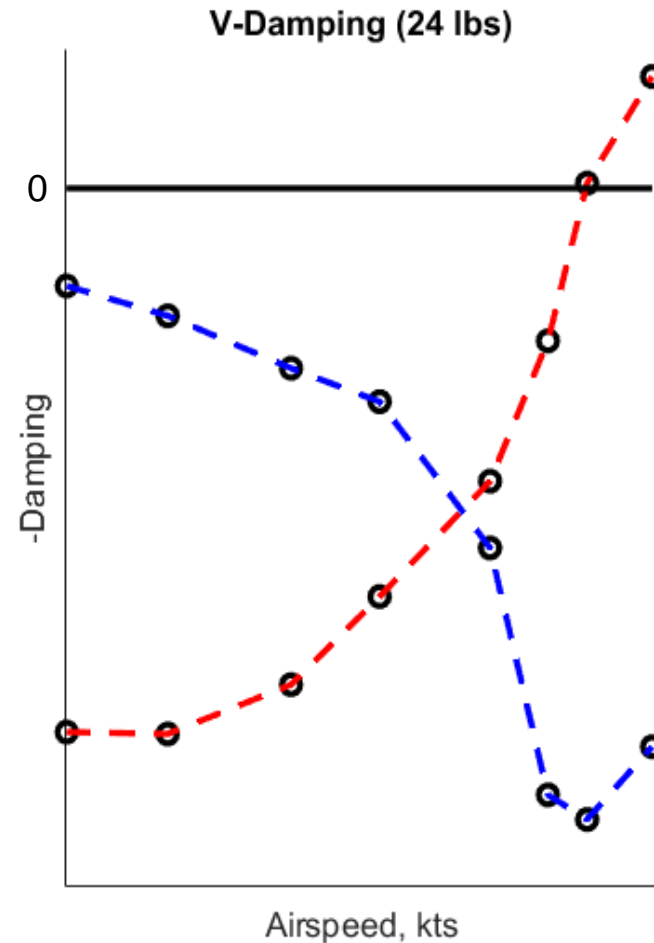
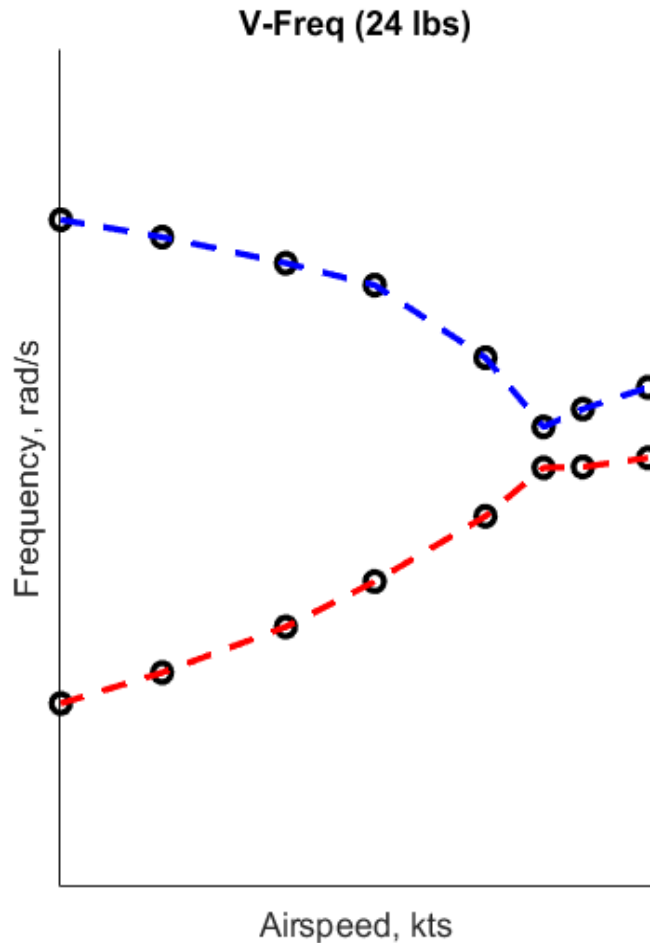



# Predicted BFF mode shape

*X-56A Multi-Utility Technology Test-bed*

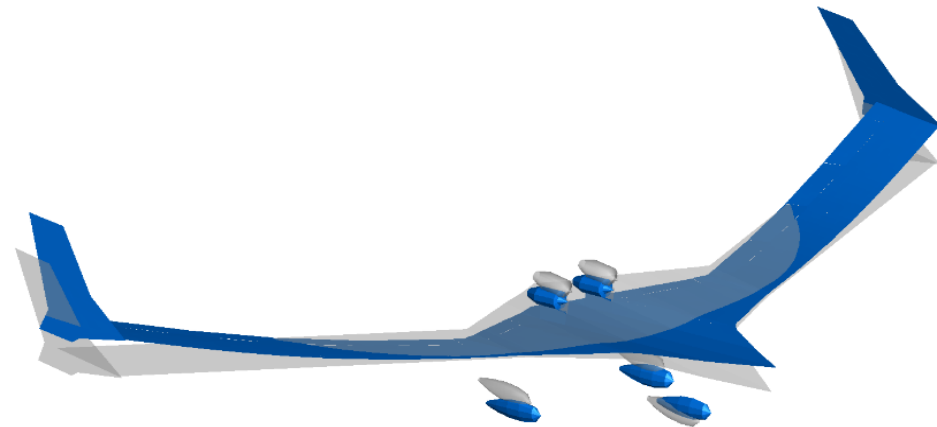
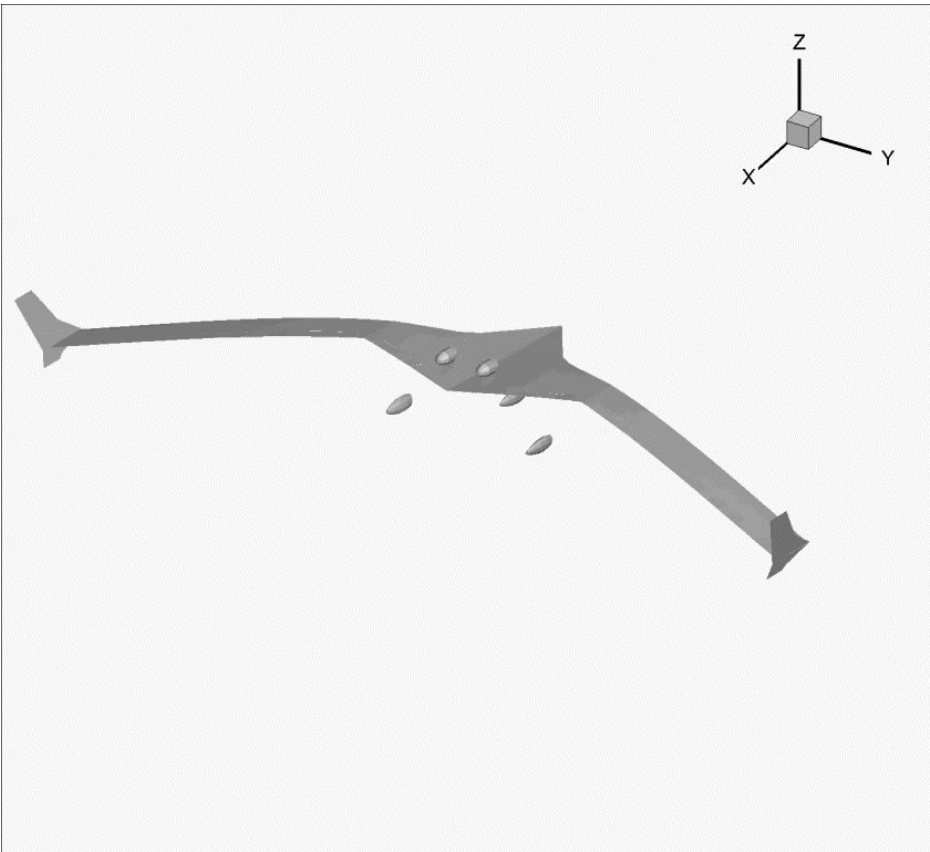

*X-56A Multi-Utility Technology Test-bed*

Chase video of BFF motion

Final video removed for transfer

# Flutter suppression

X-56A Multi-Utility Technology Test-bed

- Turned control system off in flight to demonstrate flutter, momentarily, (and suppression of it)

## Right Before Flutter

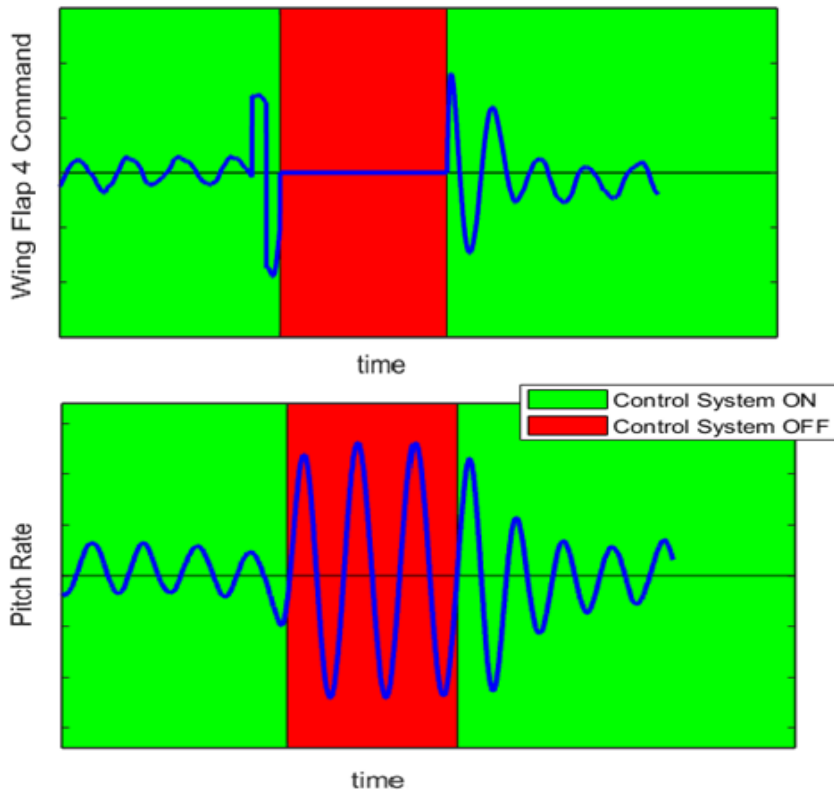

## Slightly Past Flutter

