



# Prognostics and Health Monitoring: Application to Electric Vehicles

**Dr. Chetan S. Kulkarni**  
chetan.s.kulkarni@nasa.gov

SGT Inc., NASA Ames Research Center,  
Prognostics Center of Excellence  
Moffett Field, CA

**MARCON 2017**

# Motivation

- Batteries increasingly used in more and more systems as a power source
  - Electric cars
  - Electric aircraft
  - Space missions/small satellites
  - Other electric and utility vehicles
- Prediction of end-of-discharge (EOD) and end-of-life (EOL) are critical to system functions
  - How much longer can the system be used, given expected usage conditions?
  - How many more usage cycles until battery capacity is not sufficient for required system operations?

Solve using model-based prognostics approach.

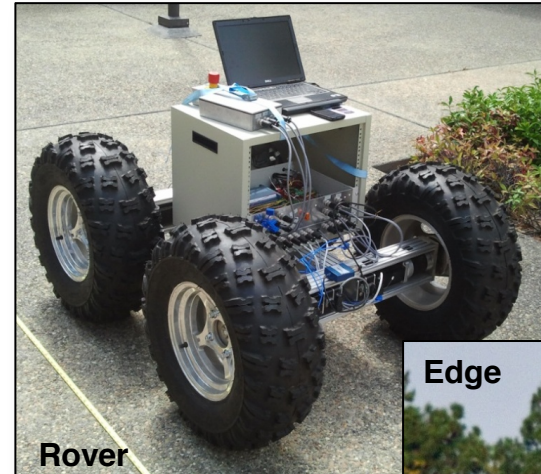

# Outline

---

- Prognostics Basics
- Prognostics Algorithms
  - Prognostic Architecture
  - Dynamic state and state-of-charge estimation
- Modeling
  - Electric circuit equivalent (for EOD prediction)
  - Electrochemistry-based model (for EOD and EOL prediction)
- Applications
  - Rover
  - Edge 540-T electric aircraft

---

# Prognostics Basics

# What is Prognostics?

---

- Prognosis = A forecast of the future course, or outcome, of a situation; a [prediction](#)
- We are more familiar with prognosis in a health management context:
  - Prediction of end of life (EOL) and/or remaining useful life (RUL)
  - EOL refers to a failure of the component as defined by its functional specifications

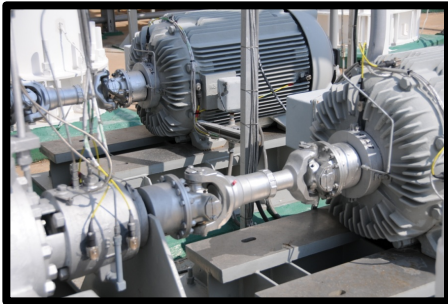

# The Basic Idea

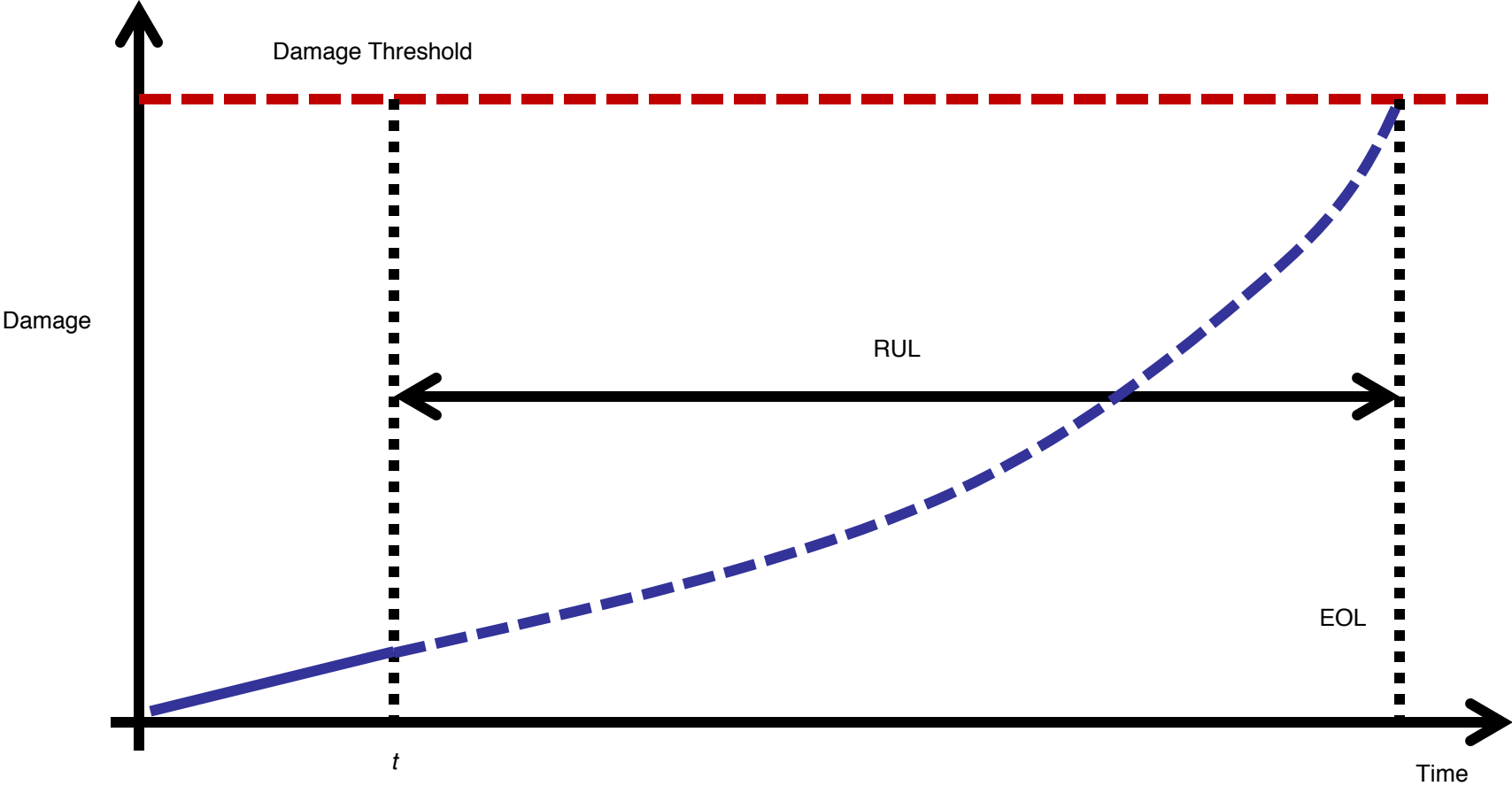

# Why Prognostics?

## Example: UAV Mission

Visit waypoints to accomplish science objectives. Predict aircraft battery end of discharge to determine which objectives can be met. Based on prediction, plan optimal route. Replan if prediction changes.

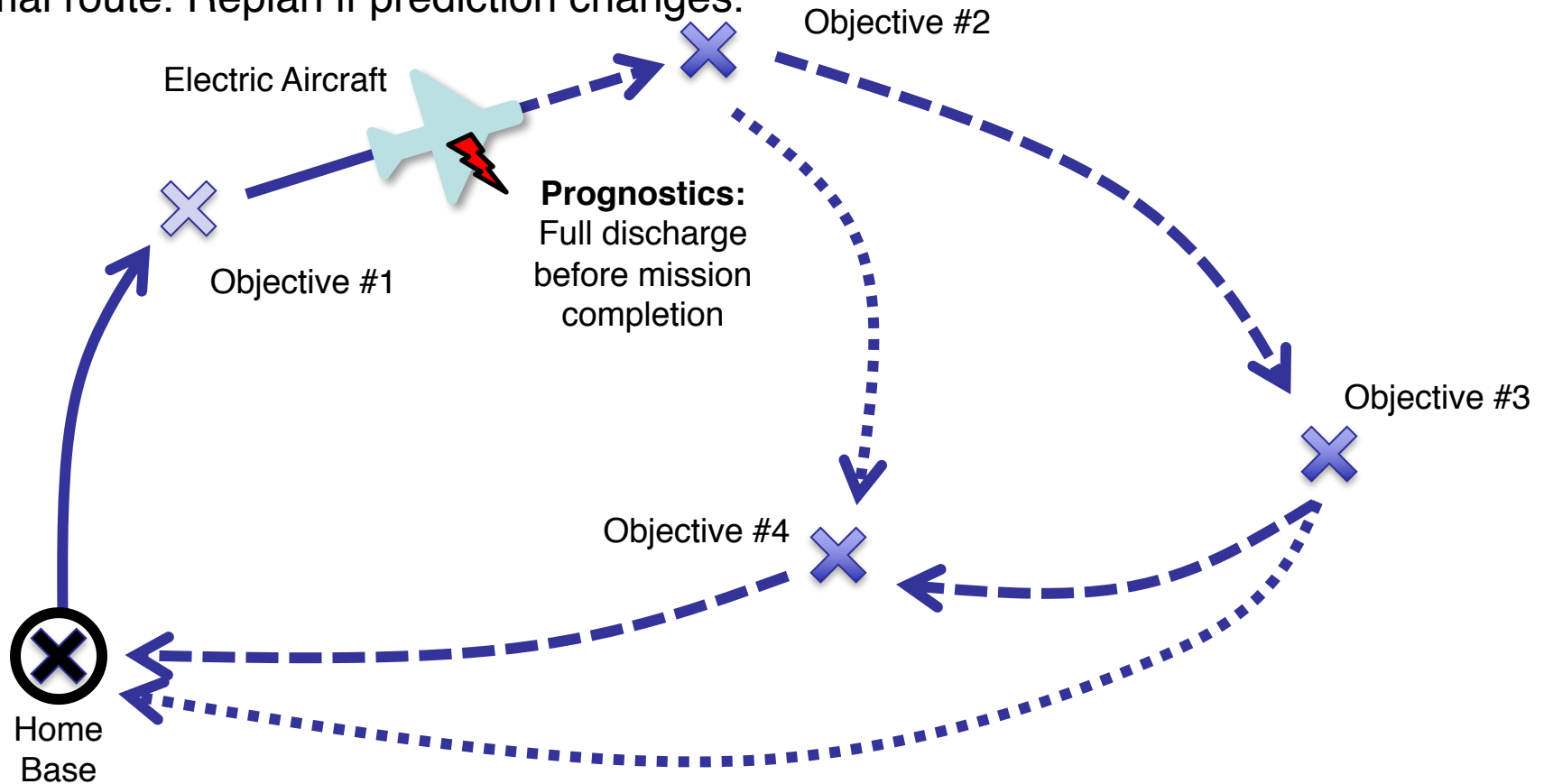

# Why Prognostics?

---

- Prognostics can enable:
  - Adopting condition-based maintenance strategies, instead of time-based maintenance
  - Optimally scheduling maintenance
  - Optimally planning for spare components
  - Reconfiguring the system to avoid using the component before it fails
  - Prolonging component life by modifying how the component is used (e.g., load shedding)
  - Optimally plan or replan a mission
- System operations can be optimized in a variety of ways

# The Basic Idea Revisited

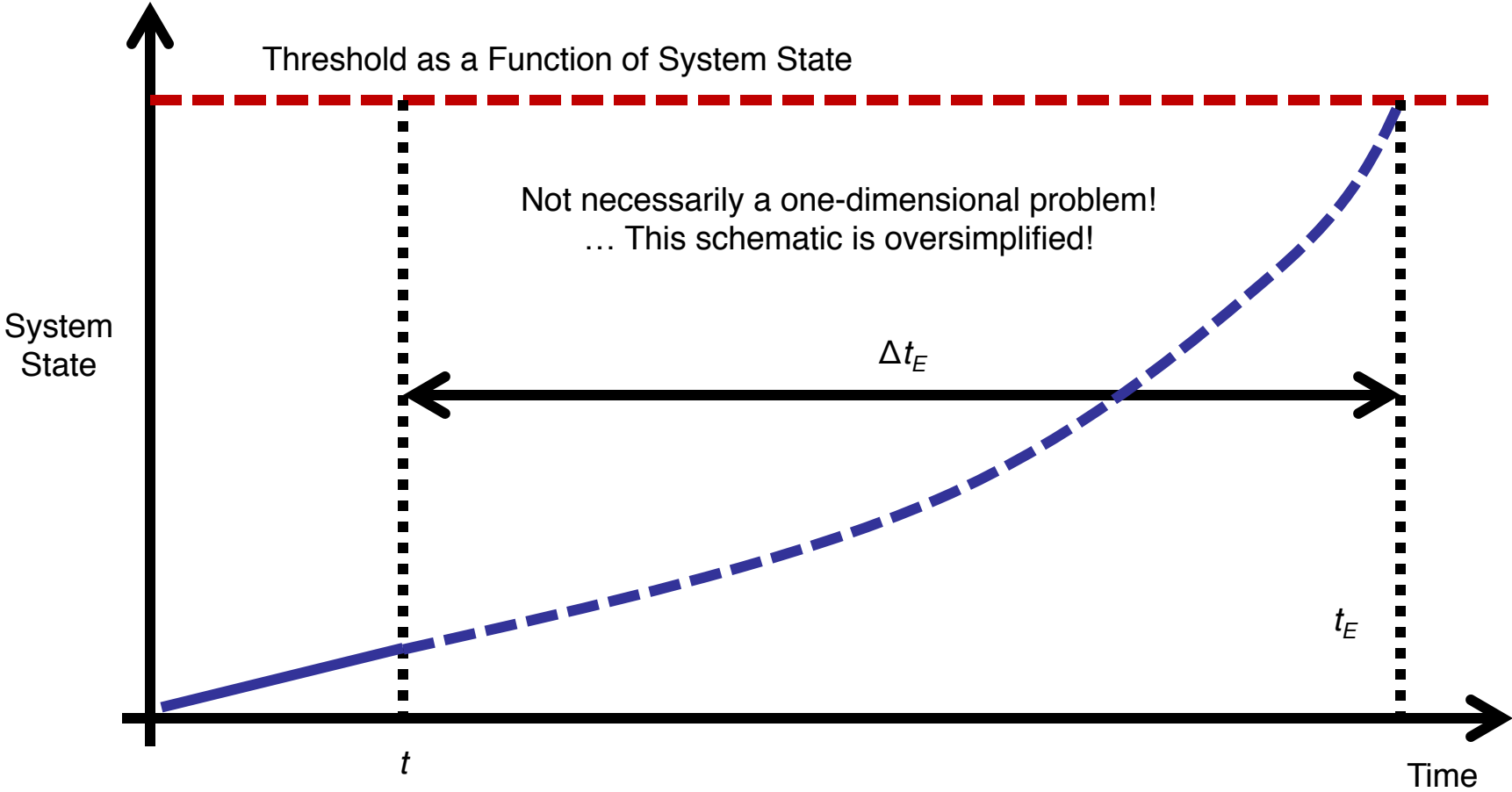

# The Basic Idea : Batteries Example

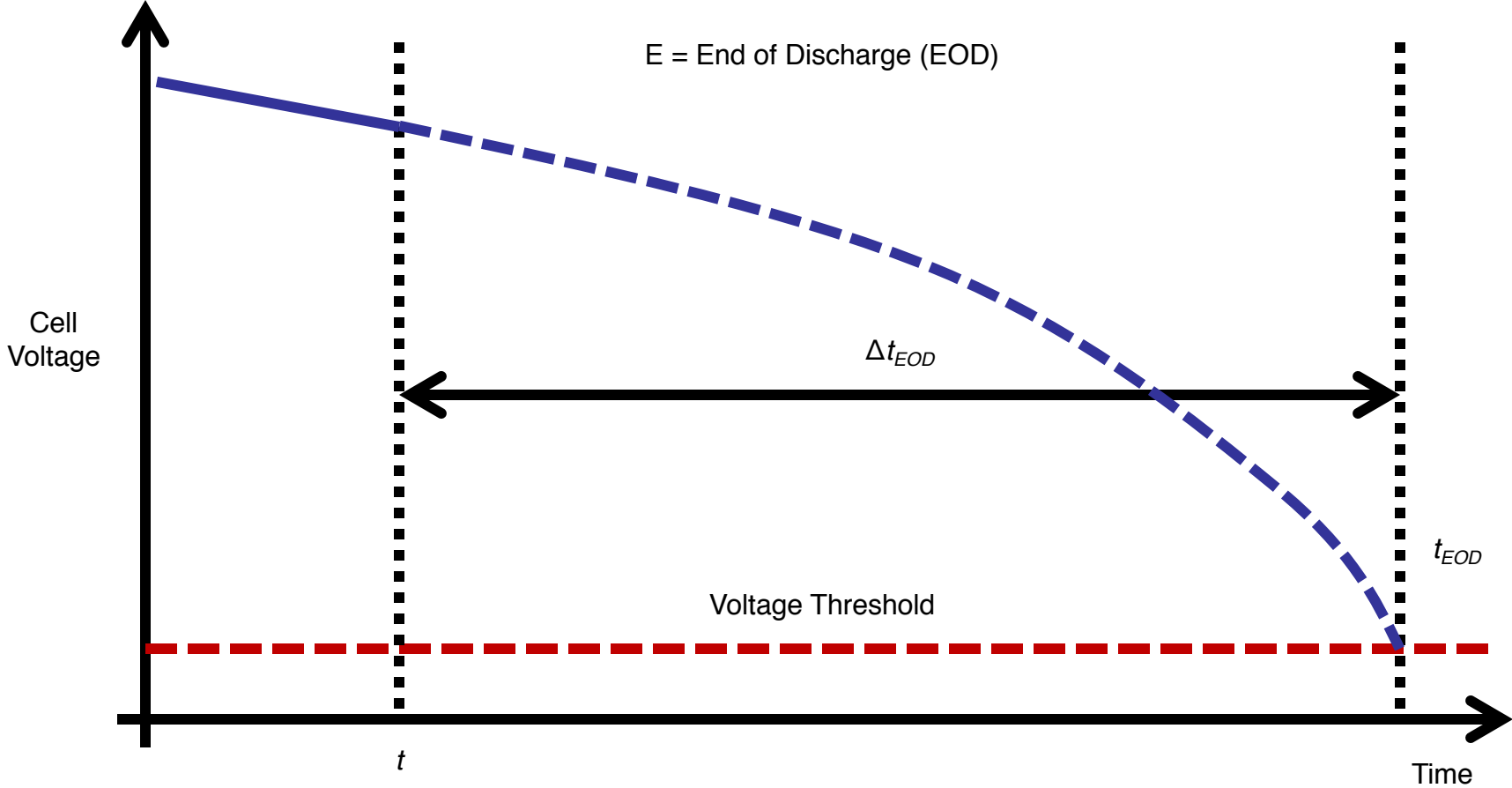

# The Basic Idea : Batteries Example

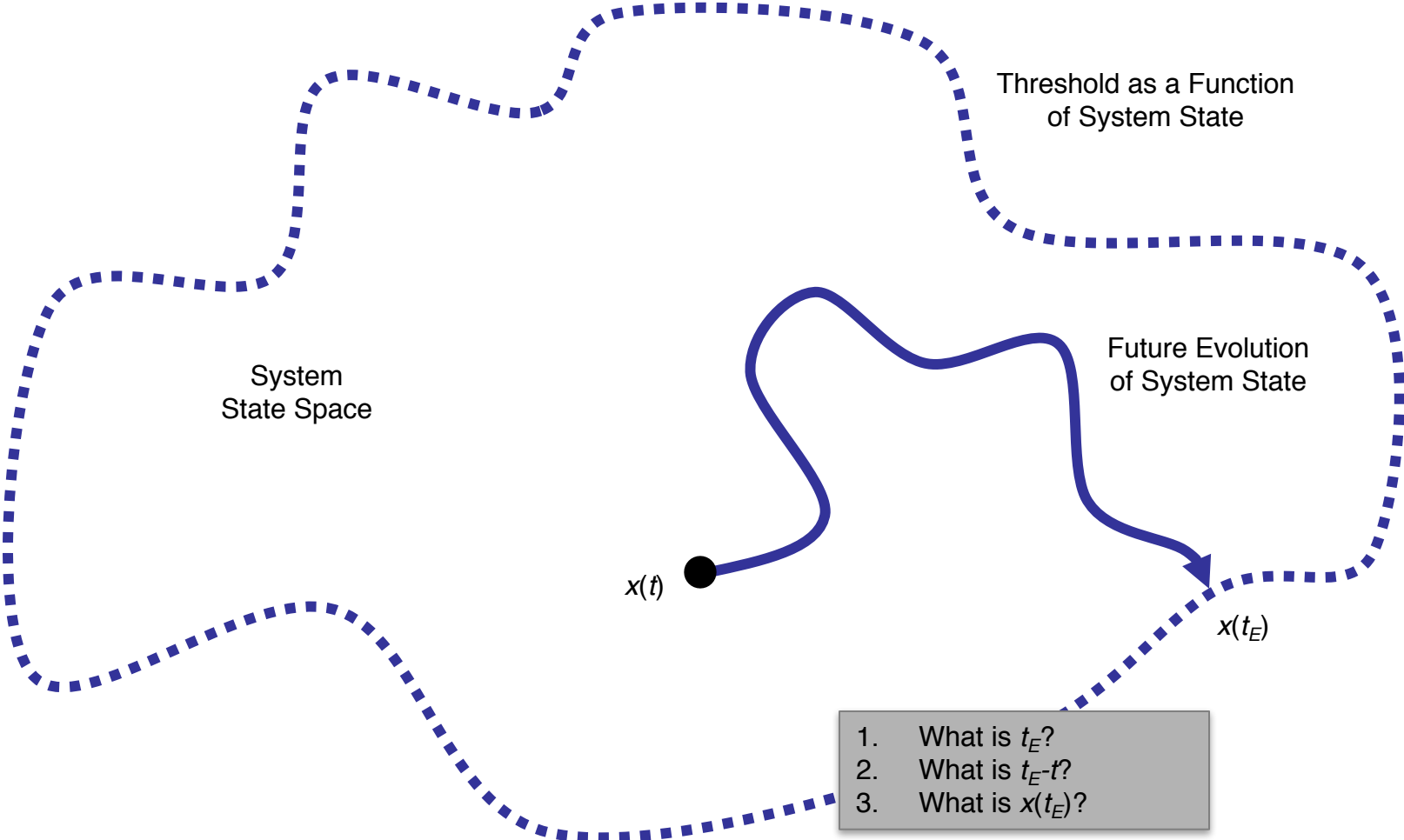

---

# Prognostics Algorithms

# Integrated Prognostics Architecture

- System (battery) gets inputs (current) and produces outputs (voltage)
- State estimation computes estimate of state given estimates of age parameters
- EOD prediction computes prediction of time of EOD, given state and age parameter estimates
- Age parameter estimation computes estimates of age parameters
- Age rate parameter estimation computes parameters defining aging rate progression
- EOL prediction computes prediction of time of EOL, given age parameter and age rate parameter estimates

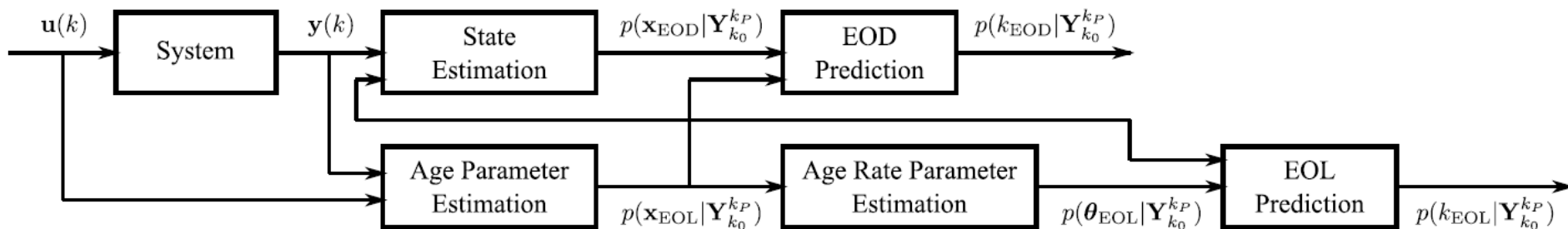

# State Estimation

---

- What is the current system state and its associated uncertainty?
  - Input: system outputs  $y$  from  $k_0$  to  $k$ ,  $y(k_0:k)$
  - Output:  $p(x(k), \theta(k) | y(k_0:k))$
- Battery models are nonlinear, so require nonlinear state estimator (e.g., extended Kalman filter, particle filter, unscented Kalman filter)
- Use unscented Kalman filter (UKF)
  - Straight forward to implement and tune performance
  - Computationally efficient (number of samples linear in size of state space)

# Prediction

---

- Most algorithms operate by simulating samples forward in time until  $E$
- Algorithms must account for several sources of uncertainty besides that in the initial state
  - A representation of that uncertainty is required for the selected prediction algorithm
  - A specific description of that uncertainty is required (e.g., mean, variance)

# Prediction Algorithm

- The  $\mathbb{P}$  function takes an initial state, and a parameter, an input, and a process noise trajectory
  - Simulates state forward using  $\mathbf{f}$  until  $E$  is reached to compute  $k_E$  for a single sample
- Top-level prediction algorithm calls  $\mathbb{P}$ 
  - These algorithms differ by how they compute samples upon which to call  $\mathbb{P}$
- Monte Carlo algorithm (MC) takes as input
  - Initial state-parameter estimate
  - Probability distributions for the surrogate variables for the parameter, input, and process noise trajectories
  - Number of samples,  $N$
- MC samples from its input distributions, and computes  $k_E$
- The “construct” functions describe how to construct a trajectory given trajectory parameters

---

**Algorithm 1**  $k_E(k_P) \leftarrow \mathbb{P}(\mathbf{x}(k_P), \Theta_{k_P}, \mathbf{U}_{k_P}, \mathbf{V}_{k_P})$

---

```

1:  $k \leftarrow k_P$ 
2:  $\mathbf{x}(k) \leftarrow \mathbf{x}(k_P)$ 
3: while  $T_E(\mathbf{x}(k), \Theta_{k_P}(k), \mathbf{U}_{k_P}(k)) = 0$  do
4:    $\mathbf{x}(k+1) \leftarrow \mathbf{f}(k, \mathbf{x}(k), \Theta_{k_P}(k), \mathbf{U}_{k_P}(k), \mathbf{V}_{k_P}(k))$ 
5:    $k \leftarrow k+1$ 
6:    $\mathbf{x}(k) \leftarrow \mathbf{x}(k+1)$ 
7: end while
8:  $k_E(k_P) \leftarrow k$ 

```

---



---

**Algorithm 2**  $\{k_E^{(i)}\}_{i=1}^N = \text{MC}(p(\mathbf{x}(k_P), \boldsymbol{\theta}(k_P)|\mathbf{y}(k_0:k_P)), p(\boldsymbol{\lambda}_\theta), p(\boldsymbol{\lambda}_u), p(\boldsymbol{\lambda}_v), N)$

---

```

1: for  $i = 1$  to  $N$  do
2:    $(\mathbf{x}^{(i)}(k_P), \boldsymbol{\theta}^{(i)}(k_P)) \sim p(\mathbf{x}(k_P), \boldsymbol{\theta}(k_P)|\mathbf{y}(k_0:k_P))$ 
3:    $\boldsymbol{\lambda}_\theta^{(i)} \sim p(\boldsymbol{\lambda}_\theta)$ 
4:    $\Theta_{k_P}^{(i)} \leftarrow \text{construct}\Theta(\boldsymbol{\lambda}_\theta^{(i)}, \boldsymbol{\theta}^{(i)}(k_P))$ 
5:    $\boldsymbol{\lambda}_u^{(i)} \sim p(\boldsymbol{\lambda}_u)$ 
6:    $\mathbf{U}_{k_P}^{(i)} \leftarrow \text{construct}\mathbf{U}(\boldsymbol{\lambda}_u^{(i)})$ 
7:    $\boldsymbol{\lambda}_v^{(i)} \sim p(\boldsymbol{\lambda}_v)$ 
8:    $\mathbf{V}_{k_P}^{(i)} \leftarrow \text{construct}\mathbf{V}(\boldsymbol{\lambda}_v^{(i)})$ 
9:    $k_E^{(i)} \leftarrow \mathbb{P}(\mathbf{x}^{(i)}(k_P), \Theta_{k_P}^{(i)}, \mathbf{U}_{k_P}^{(i)}, \mathbf{V}_{k_P}^{(i)})$ 
10: end for

```

---

---

# Modeling

# Battery Modeling

## – Equivalent Circuit Empirical Models

- Most common approach
- Various model complexities used
- Difficulty in incorporating aging effects

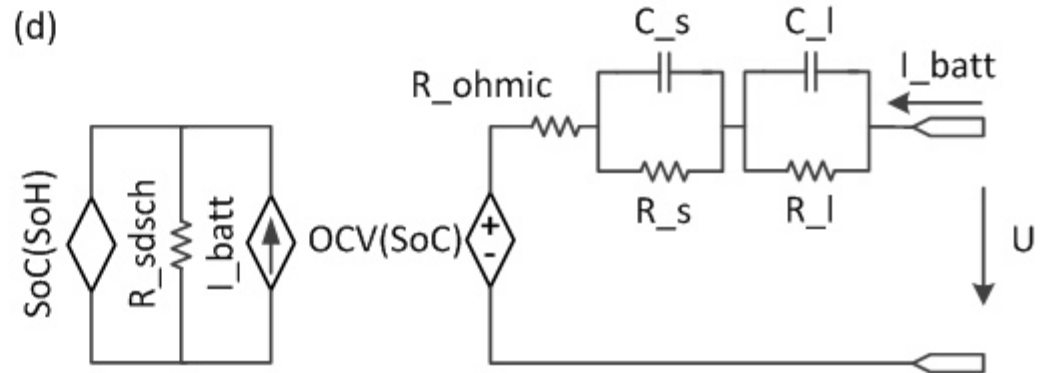
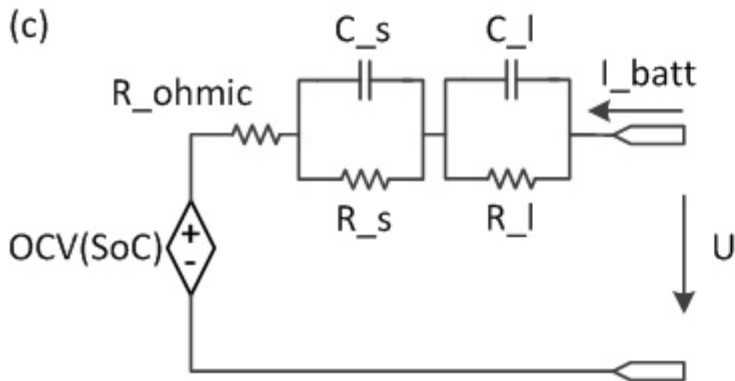
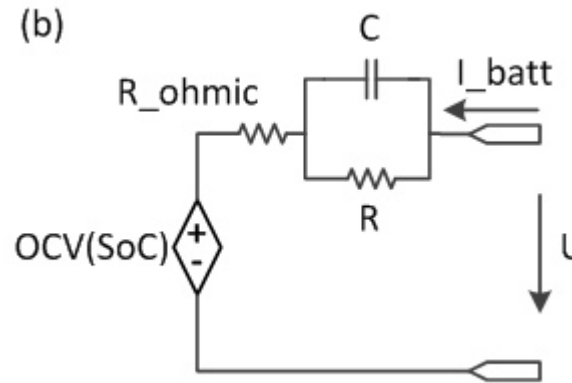
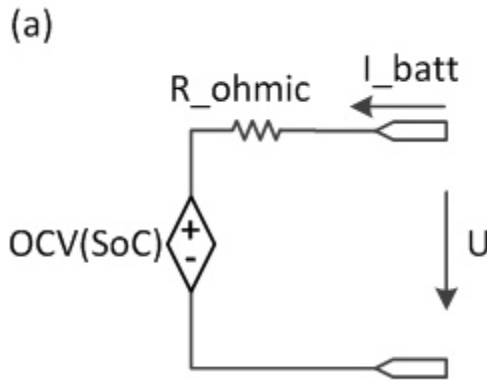

# Battery Model– Tuned using laboratory data

- An equivalent circuit battery model is used to represent the battery terminal voltage as a function of current and the charge stored in 3 capacitive elements

$$x = [q_b \ q_{cp} \ q_{Cs}]^T$$

$$\dot{x} = \begin{bmatrix} 0 & 0 & 0 \\ 0 & -\frac{1}{R_{cp}C_{cp}} & 0 \\ 0 & 0 & -\frac{1}{R_sC_s} \end{bmatrix} x + \begin{bmatrix} -1 \\ 1 \\ 1 \end{bmatrix} i + \xi$$

$$y = V = \begin{bmatrix} \frac{1}{C_b} & -\frac{1}{C_{cp}} & -\frac{1}{C_s} \end{bmatrix} \cdot x$$

- Two laboratory loading experiments are used to fit the following parameterization coefficients

$$SOC = 1 - \frac{q_{max} - q_b}{C_{max}}$$

$$C_b = C_{Cb0} + C_{Cb1} \cdot SOC + C_{Cb2} \cdot SOC^2 + C_{Cb3} \cdot SOC^3$$

$$C_{cp} = C_{cp0} + C_{cp1} \cdot \exp(C_{cp2} (1 - SOC))$$

$$R_{cp} = R_{cp0} + R_{cp1} \cdot \exp(R_{cp2} (1 - SOC))$$

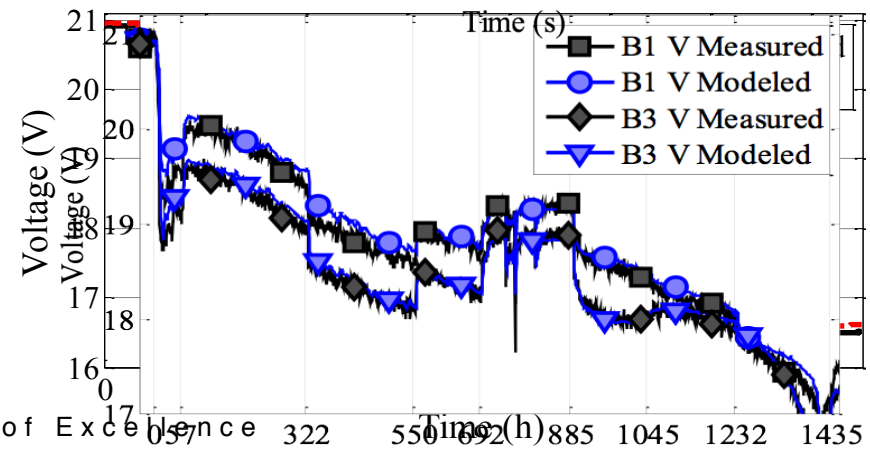
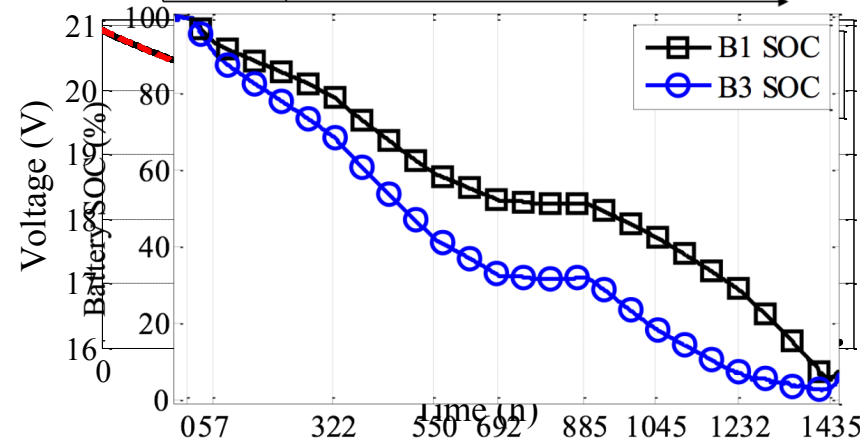
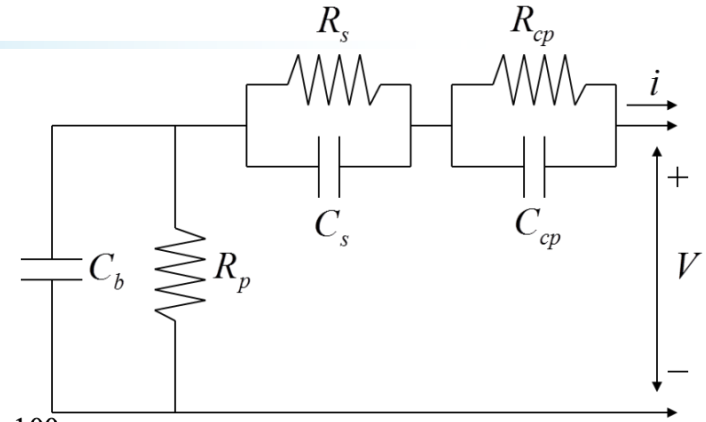

# Battery Modeling

## – Electrochemical Models vs. Empirical Models

- Battery physics models enable more direct representation of age-related changes in battery dynamics than empirical models
- Typically have a higher computational cost and more unknown parameters

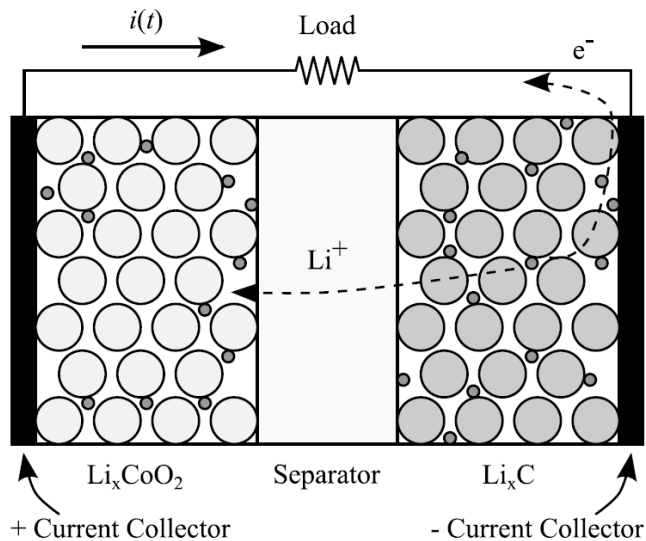

### Discharge

Reduction at pos. electrode:

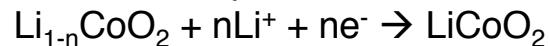

Oxidation at neg. electrode:

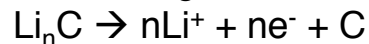

Current flows + to -

Electrons flow - to +

Lithium ions flow - to +

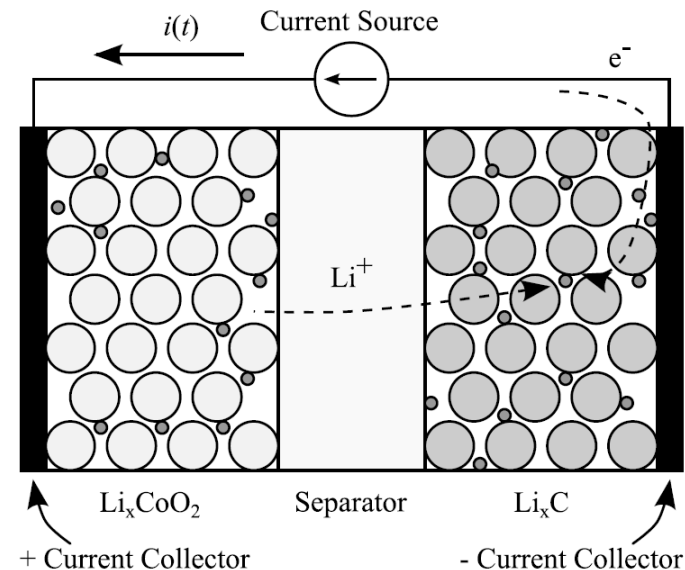

### Charge

Oxidation at pos. electrode:



Reduction at neg. electrode:

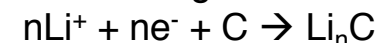

Current flows - to +

Electrons flow + to -

Lithium ions flow + to -

# Electrochemical Li-ion Model

- Lumped-parameter, ordinary differential equations
- Capture voltage contributions from different sources
  - Equilibrium potential → Nernst equation with Redlich-Kister expansion
  - Concentration overpotential → split electrodes into surface and bulk control volumes
  - Surface overpotential → Butler-Volmer equation applied at surface layers
  - Ohmic overpotential → Constant lumped resistance accounting for current collector resistances, electrolyte resistance, solid-phase ohmic resistance

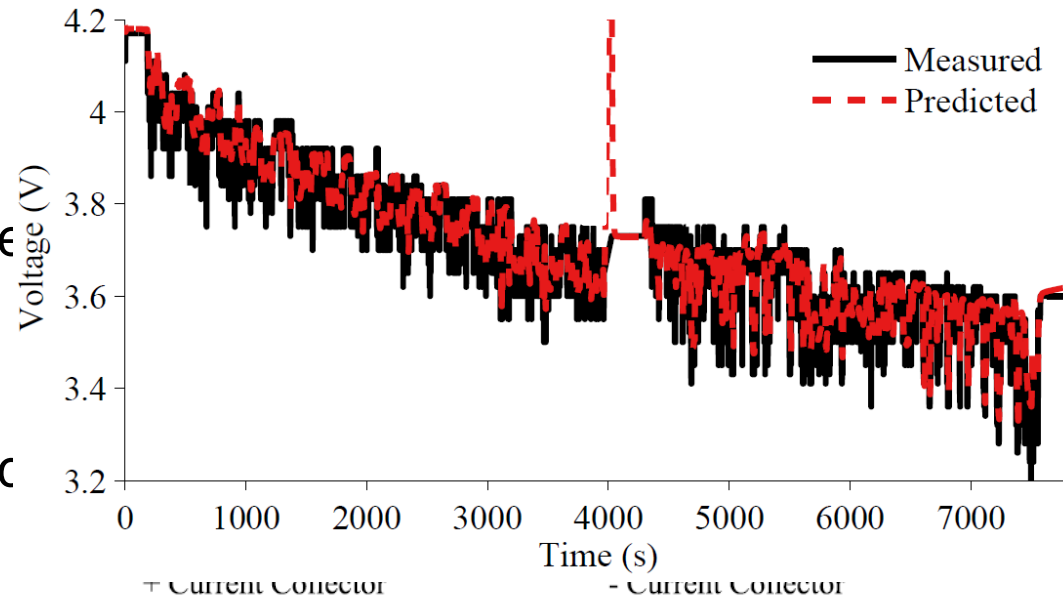

# Battery Aging

- Contributions from both decrease in mobile Li ions (lost due to side reactions related to aging) and increase in internal resistance
  - Modeled with decrease in " $q^{max}$ " parameter, used to compute mole fraction
  - Modeled with increase in " $R_o$ " parameter capturing lumped resistances

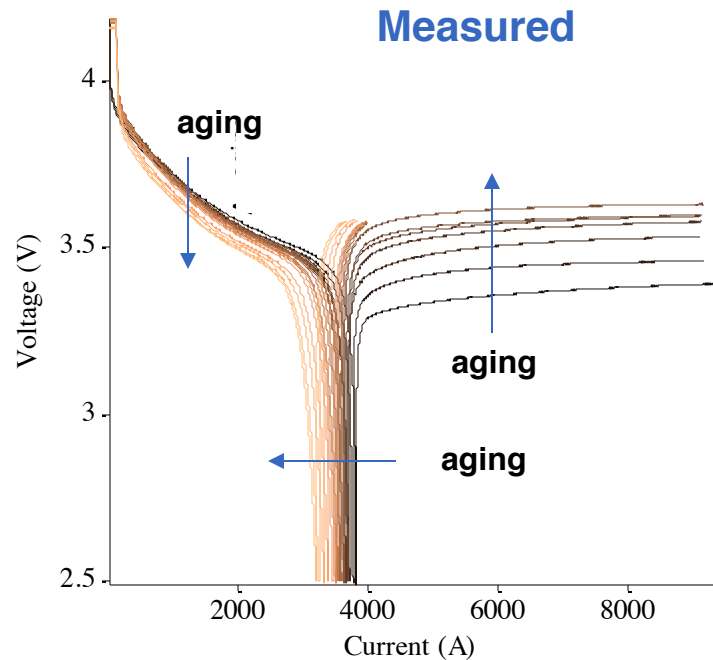

- Cycle 16
- Cycle 26
- Cycle 36
- Cycle 46
- Cycle 56
- Cycle 66
- Cycle 76
- Cycle 86
- Cycle 96
- Cycle 106
- Cycle 116
- Cycle 126
- Cycle 136
- Cycle 146
- Cycle 156
- Cycle 166
- Cycle 176
- Cycle 186

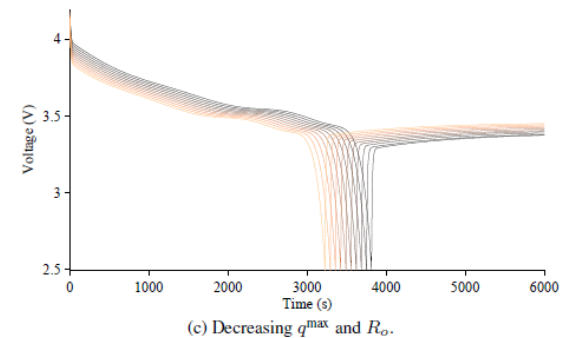
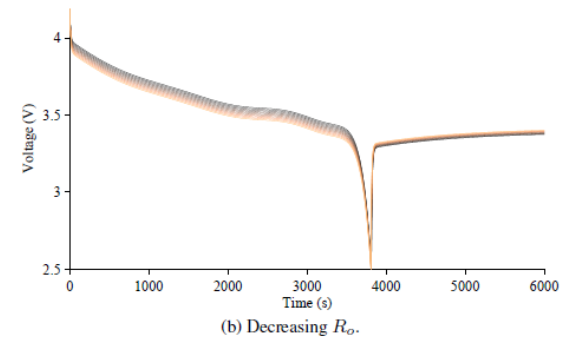
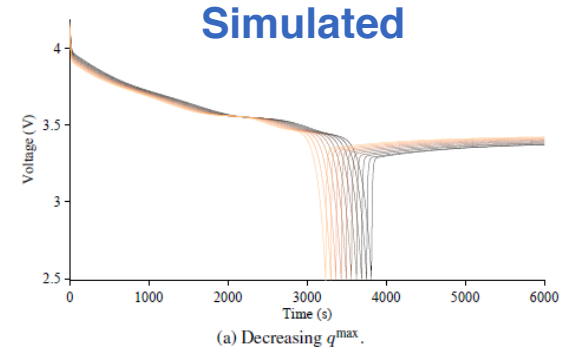

---

# Applications

# Fielded Applications

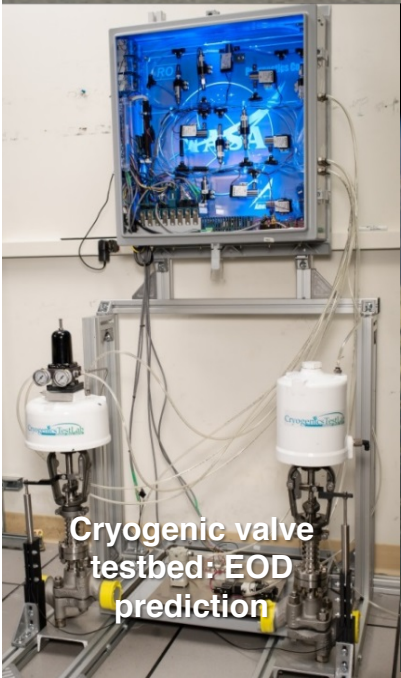
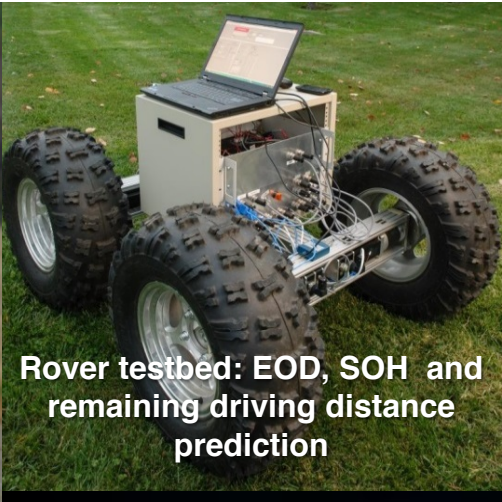

# Rover

- Planetary rover testbed at NASA Ames Research Center
  - 24 lithium ion batteries, two parallel sets of 12 in series
  - Batteries power 4 motors, one for each wheel (skid steering)
- Rover operated in two driving modes
  - Unstructured driving
    - Rover is driven freely by an operator, without prior knowledge of actions
  - Structured driving
    - Rover has a given mission, to visit a set of waypoints
    - Rover moves along, visiting waypoints
    - End-of-discharge prediction is required in order to ensure the given set of waypoints can be visited, and if not, to replan the route to optimize mission value

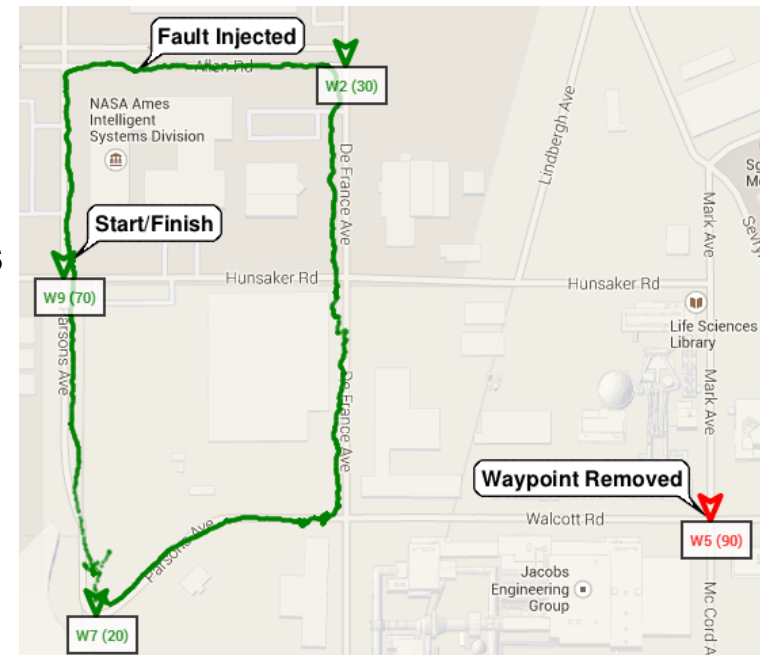

# Results: Unstructured Driving

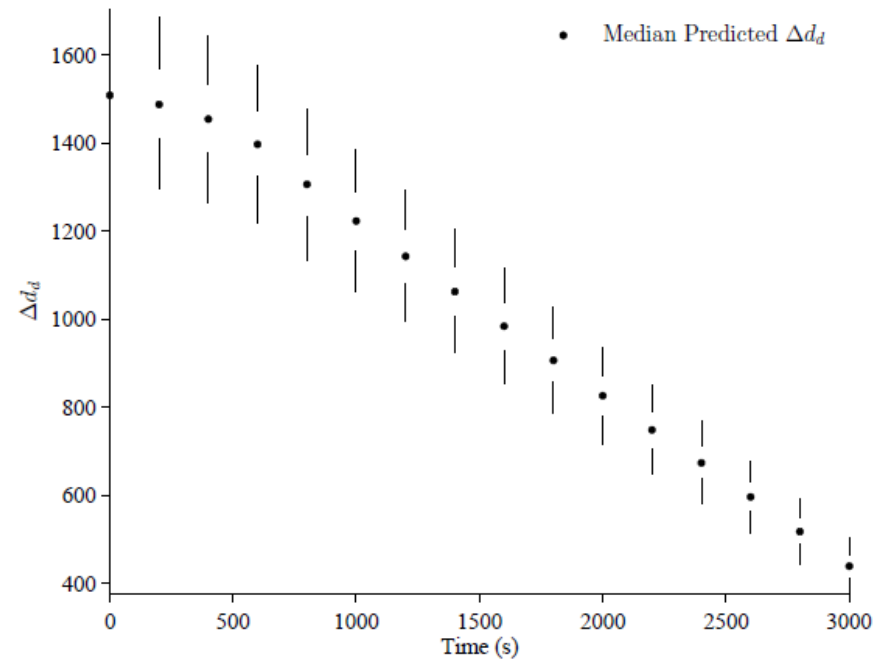
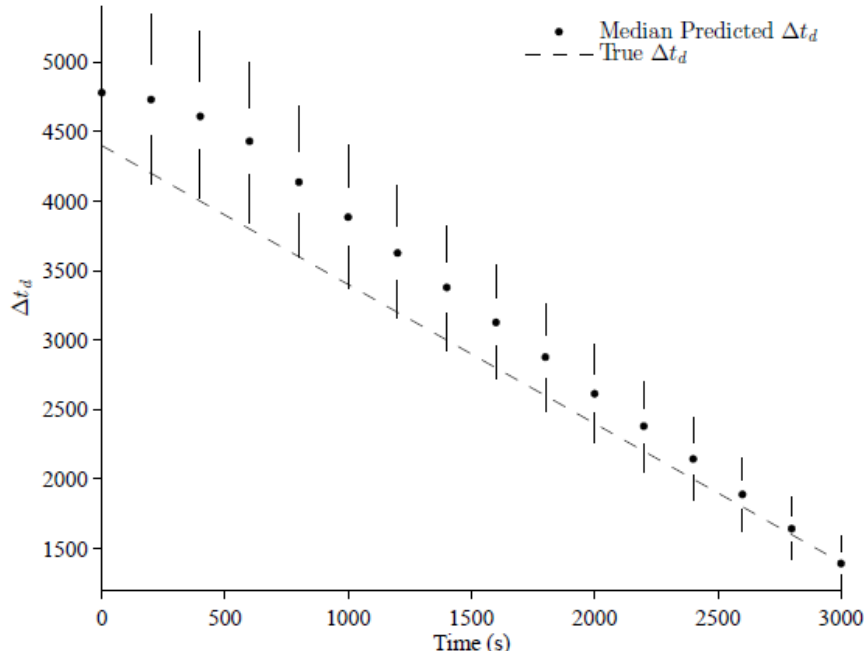

- Accuracy of remaining driving time and distance predictions improves as EOD is approached.
- True average power and average power for this scenario are different
- True predictions are captured within the considered uncertainty.

# Results: Structured Driving

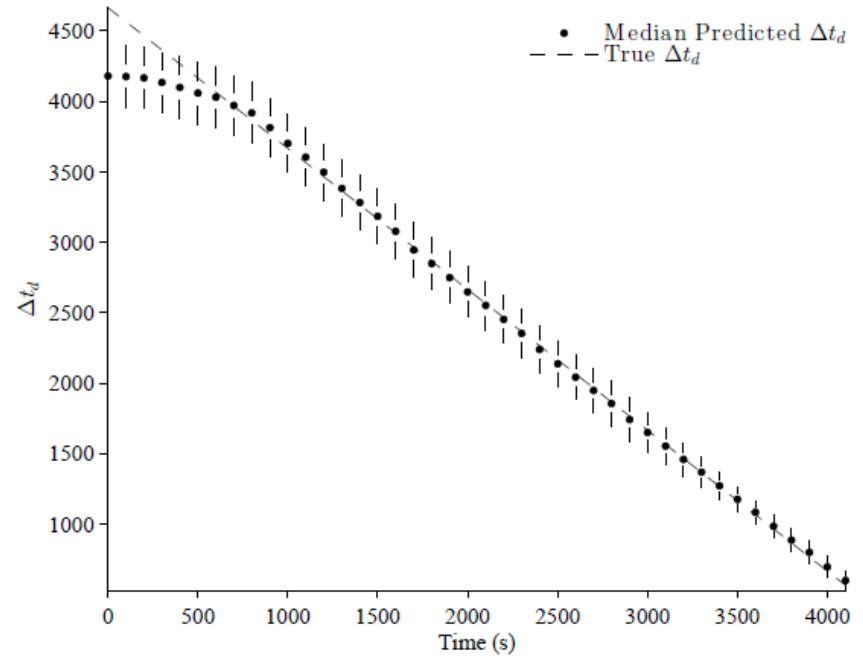
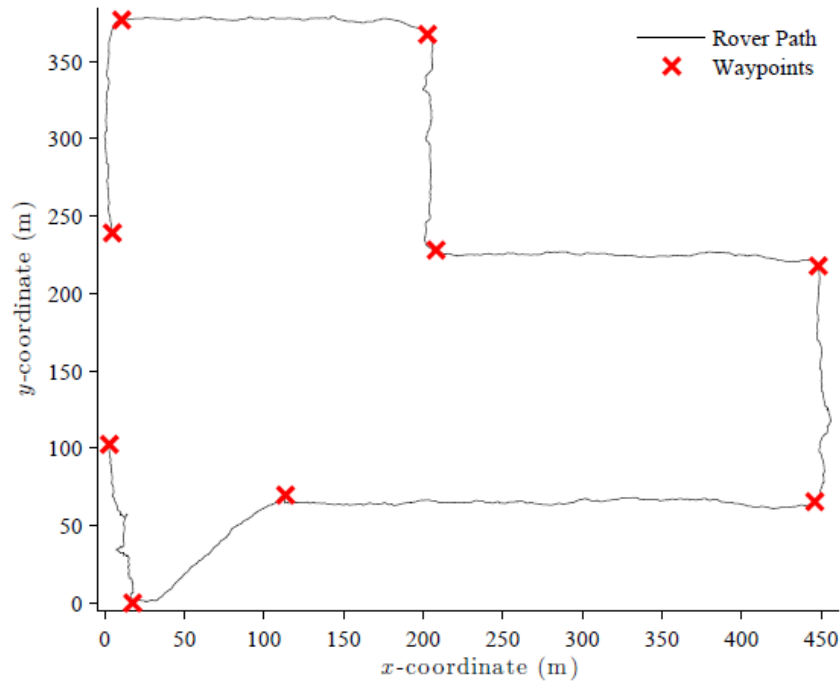

Predictions are very accurate since rover travels at a known fixed average speed, and waypoints are known.

Uncertainty in predictions is *significantly less than* for unstructured driving, since more information about future inputs are known.

Predictions are under at the start because power drawn for first 500 s is half the average.

# Edge 540-T

- Subscale electric aircraft operated at NASA Langley Research Center
- Powered by four sets of Li-polymer batteries
- Estimate SOC online and provide EOD and remaining flight time predictions for ground-based pilots

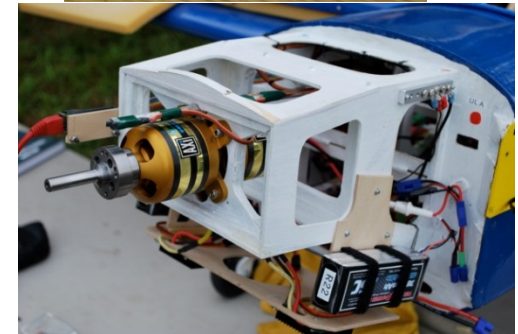
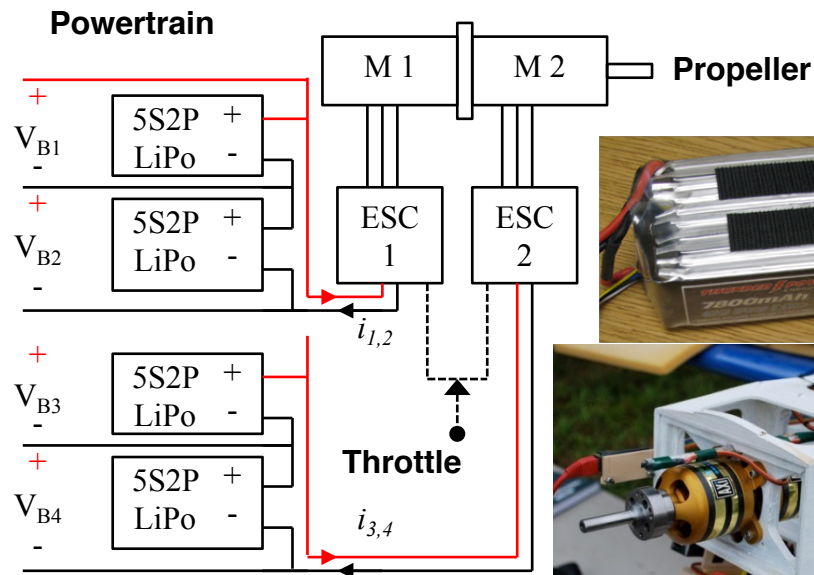

# Edge UAV Use Case

- Piloted and autonomous missions, visiting waypoints
- Require 2-minute warning for EOD so pilot/autopilot has sufficient time to land safely
  - This answer depends on battery age
  - Need to track both current level of charge and current battery age
  - Based on current battery state, current battery age, and expected future usage, can predict EOD and correctly issue 2-minute warning

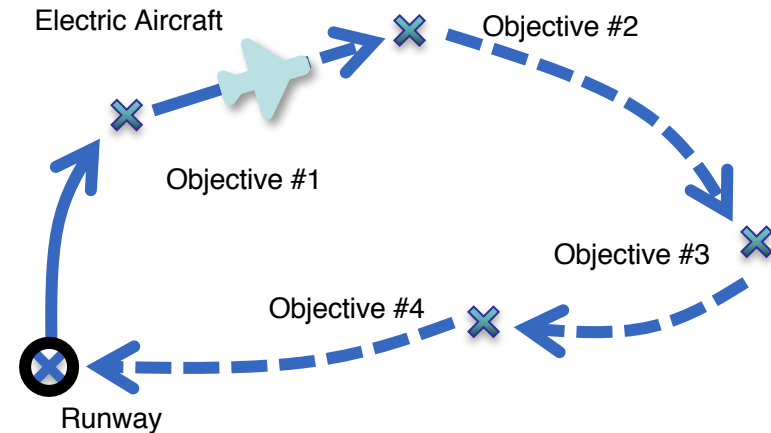

# Predication over Flight Plan

- Measured and predicted battery current, voltage and SOC different time steps
- The min, max and median predictions are plotted from each sample time until the predicated SOC reaches 30%

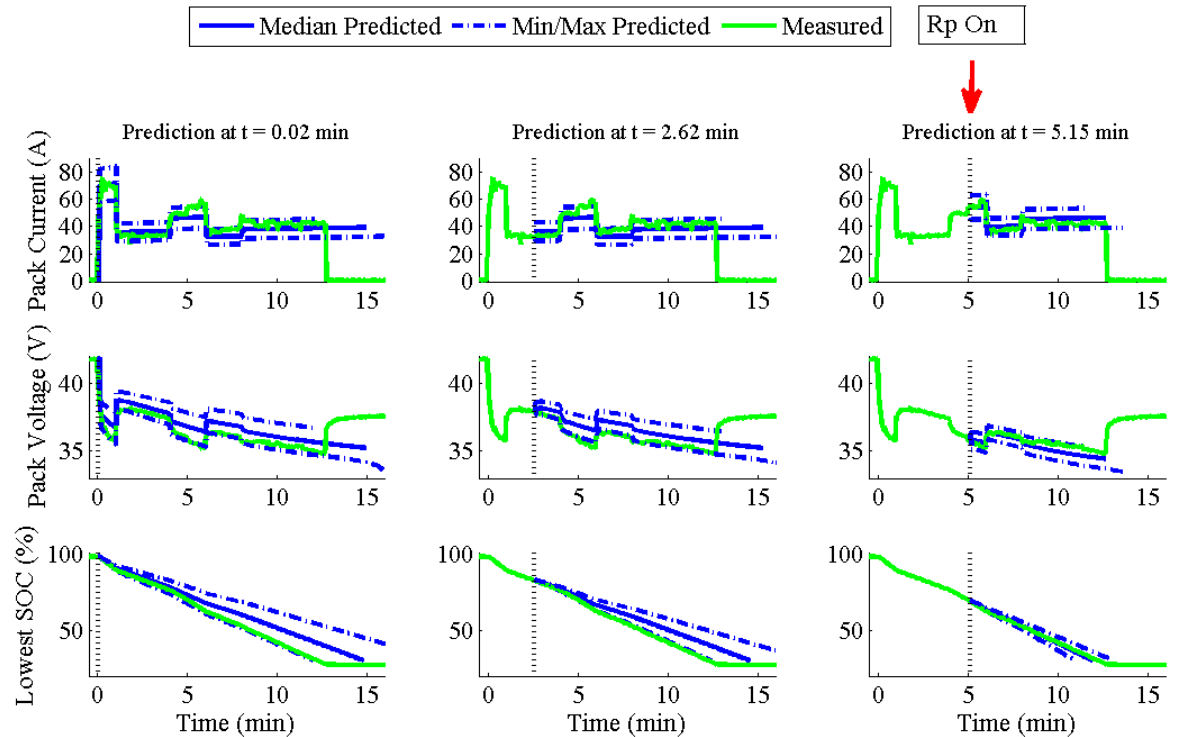
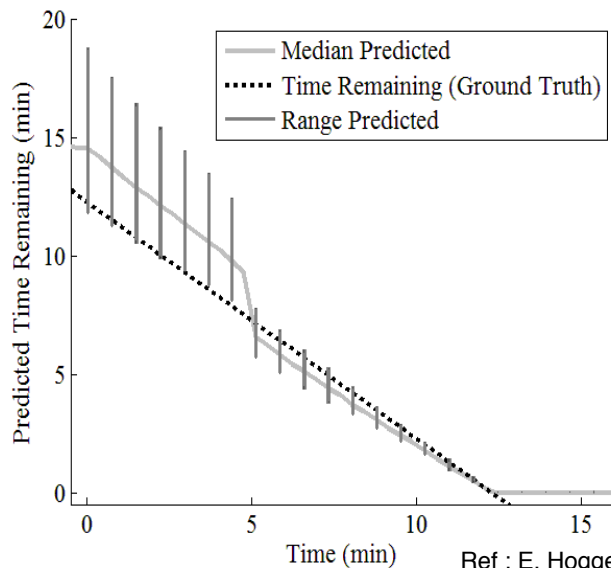

- Predictions for remaining flight time for entire flight plan
- Overestimate till parasitic load is injected
- Once the parasitic load is detected the remaining flying time time prediction shifts down.

Ref : E. Hogge et al, "Verification of a Remaining Flying Time Prediction System for Small Electric Aircraft", PHM 2015

# Performance Requirements

- Accuracy requirements for the two minute warning were specified as:
  - *The prognostic algorithm shall raise an alarm no later than two minutes before the lowest battery SOC estimate falls below 30% for at least 90% of verification trial runs.*
  - *The prognostic algorithm shall raise an alarm no earlier than three minutes before the lowest battery SOC estimate falls below 30% for at least 90% of verification trial runs.*
  - *Verification trial statistics must be computed using at least 20 experimental runs*

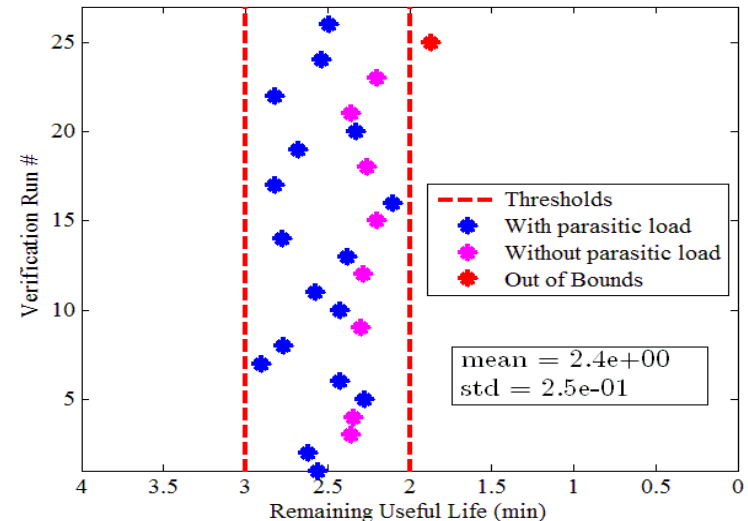
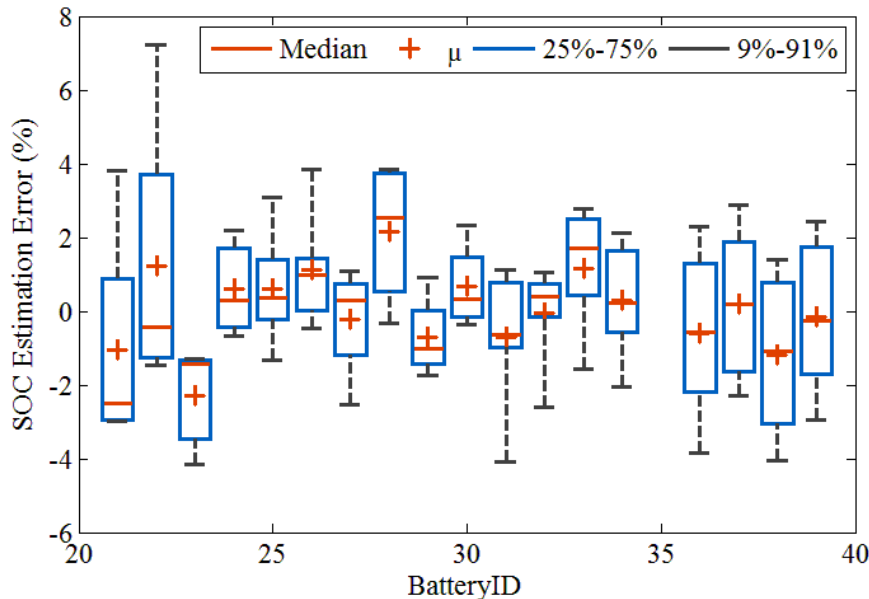

# Data Sets Available for Download

- <https://ti.arc.nasa.gov/tech/dash/pcoe/prognostic-data-repository/>

## Randomized Battery Usage Data Set

### Publications using this data set

<b>Description</b>	Batteries are continuously cycled with randomly generated current profiles. Reference charging and discharging cycles are also performed after a fixed interval of randomized usage in order to provide reference benchmarks for battery state of health.
<b>Format</b>	
<b>Datasets</b>	<ul style="list-style-type: none"> <li>+ <a href="#">Download Randomized Battery Usage Data Set 1</a> (1285 downloads)</li> <li>+ <a href="#">Download Randomized Battery Usage Data Set 2</a> (936 downloads)</li> <li>+ <a href="#">Download Randomized Battery Usage Data Set 3</a> (906 downloads)</li> <li>+ <a href="#">Download Randomized Battery Usage Data Set 4</a> (4217 downloads)</li> <li>+ <a href="#">Download Randomized Battery Usage Data Set 5</a> (825 downloads)</li> <li>+ <a href="#">Download Randomized Battery Usage Data Set 6</a> (890 downloads)</li> <li>+ <a href="#">Download Randomized Battery Usage Data Set 7</a> (857 downloads)</li> </ul>
<b>Dataset Citation</b>	B. Bole, C. Kulkarni, and M. Daigle "Randomized Battery Usage Data Set", NASA Ames Prognostics Data Repository ( <a href="http://ti.arc.nasa.gov/project/prognostic-data-repository">http://ti.arc.nasa.gov/project/prognostic-data-repository</a> ), NASA Ames Research Center, Moffett Field, CA
<b>Publication Citation</b>	B. Bole, C. Kulkarni, and M. Daigle, 'Adaptation of an Electrochemistry-based Li-Ion Battery Model to Account for Deterioration Observed Under Randomized Use', Annual Conference of the Prognostics and Health Management Society, 2014

## HIRF Battery Data Set

### Publications using this data set

<b>Description</b>	Battery Data collected from the Experiments on the Edge 540 Aircraft in HIRF Chamber. Reference document can be downloaded <a href="#">here</a>
<b>Format</b>	The set is in .mat format and has been zipped.
<b>Datasets</b>	<ul style="list-style-type: none"> <li>+ <a href="#">Download HIRF Battery Data Set 1</a> (184 downloads)</li> <li>+ <a href="#">Download HIRF Battery Data Set 2</a> (127 downloads)</li> <li>+ <a href="#">Download HIRF Battery Data Set 3</a> (131 downloads)</li> <li>+ <a href="#">Download HIRF Battery Data Set 4</a> (125 downloads)</li> <li>+ <a href="#">Download HIRF Battery Data Set 5</a> (149 downloads)</li> <li>+ <a href="#">Download HIRF Battery Data Set 6</a> (135 downloads)</li> </ul>
<b>Dataset Citation</b>	C. Kulkarni, E. Hogge, C. Quach and K. Goebel "HIRF Battery Data Set", NASA Ames Prognostics Data Repository ( <a href="http://ti.arc.nasa.gov/project/prognostic-data-repository">http://ti.arc.nasa.gov/project/prognostic-data-repository</a> ), NASA Ames Research Center, Moffett Field, CA
<b>Publication Citation</b>	Verification of a Remaining Flying Time Prediction System for Small Electric Aircraft. Edward F. Hogge, Brian M. Bole, Sixto L. Vazquez, Jose R., Annual Conference of the Prognostics and Health Management, PHM 2015

# Conclusions

---

- Focus on model-based approaches to battery state estimation and prediction
- Validate models and algorithms with data from lab experiments and fielded systems
- Defining operational requirements for different systems
- Future work in progress :
  - Temperature models
  - Higher fidelity models
  - More efficient algorithms
  - Additional applications

---

# Thank you

**Battery Prognostics Team**

**NASA Ames Research Center**

Matthew Daigle, Kai Goebel, Scott Poll

**NASA Langley Research Center**

Edward Hogge, Quach 'Patrick' Cuong Chi