



LAVA Lattice Boltzmann Development/ Application to Landing Gear

Funded by NASA ARMD – AATT and TTT Projects

Cetin Kiris, Mike Barad, and Joseph Kocheemoolayil
Computational Aerosciences Branch (TNA)
NASA Ames Research Center

Spring 2017 Acoustics Technical Working Group Meeting
April 11-12, Hampton, VA

New Aviation Horizons Flight Demo Plan



"Purpose-Built" UEST Demonstrators

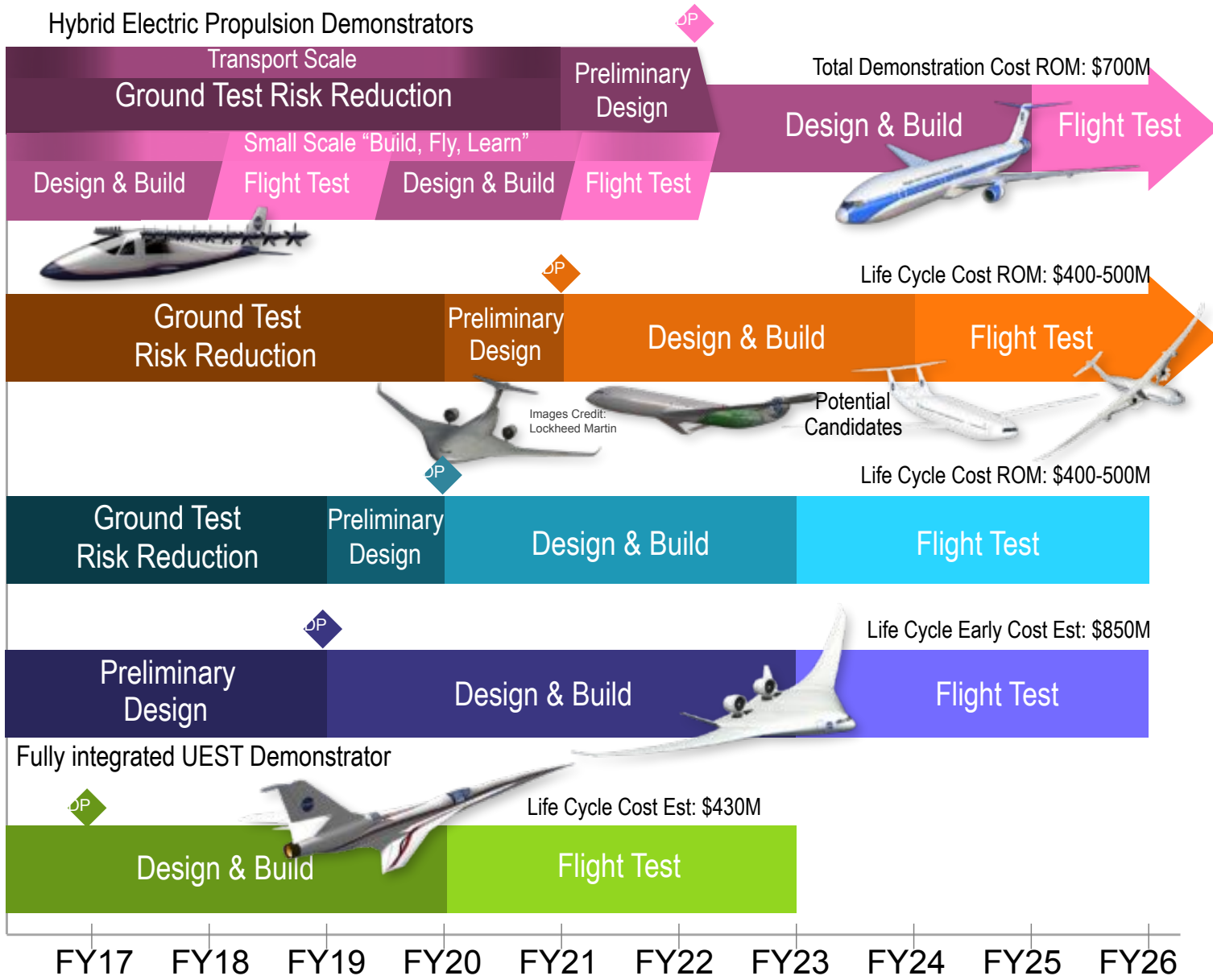

Validated HEP Concepts, Technologies And Integration for U.S. Industry to Lead the Clean Propulsion Revolution

Validated ability for U.S. Industry to Build Transform Aircraft that use 50% less energy and produce less than half of the perceived noise

Enables Low Boom Regulatory Standard and validated ability for industry to produce and operate commercial low noise supersonic aircraft

Objective



- ✓ **Increase predictive use of Computational Aero-Acoustics (CAA) capabilities for next generation aviation concepts.**
 - CFD has been utilized substantially in analysis/design for steady-state problems.
 - Computational resources are not adequate to support unsteady problems such as
 - unsteady loads,
 - buffet boundary,
 - jet and installation noise,
 - fan noise,
 - active flow control,
 - airframe noise,

- ✓ **Need to explore revolutionary techniques to provide CAA support in order to reduce the computational resources consumed by current techniques.**

Examples of Computational Aerosciences



Aerodynamic Simulation System

- Geometric complexity and fast turn around time
- Flexible meshing: Cartesian, unstructured, structured

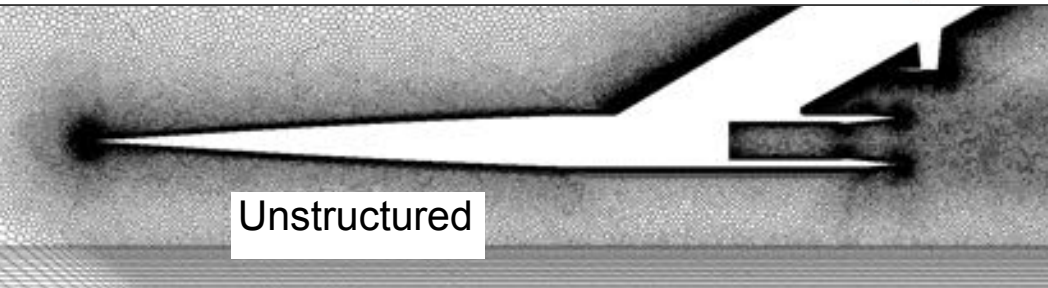
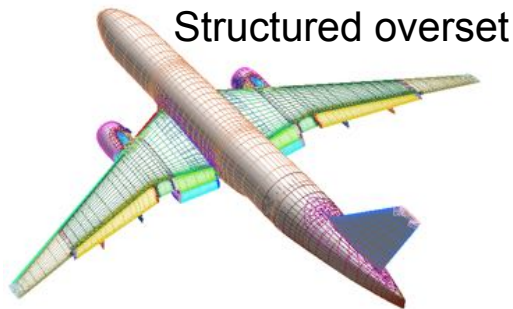
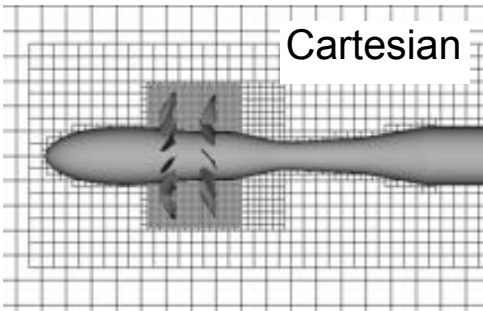

Aerostructural Simulation & Design

- Wing shape varies throughout mission profile
- Aero-structural coupling for design process

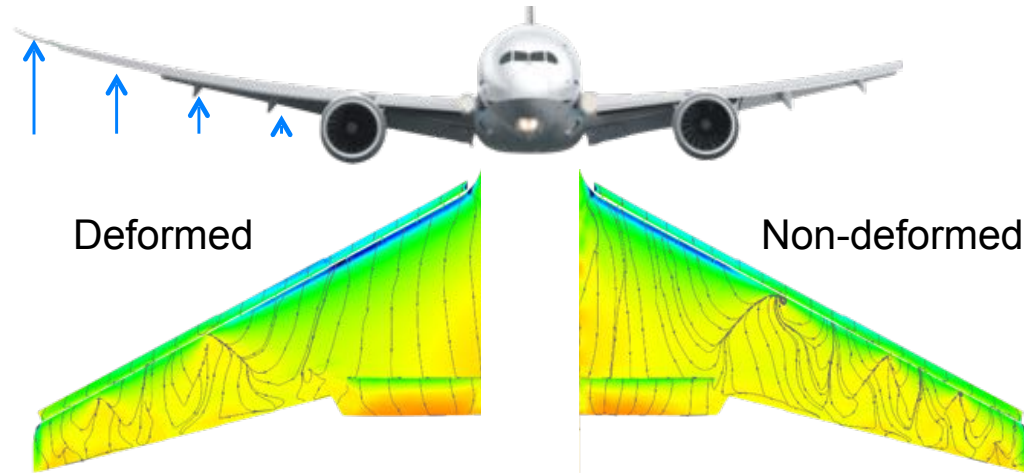

Automated Aero-Database

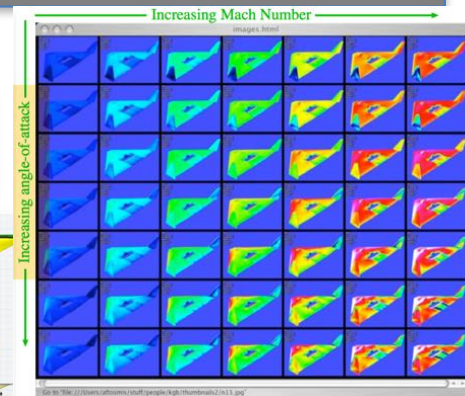

Aeroacoustics Simulation

Proposed Enhanced CAA Capability

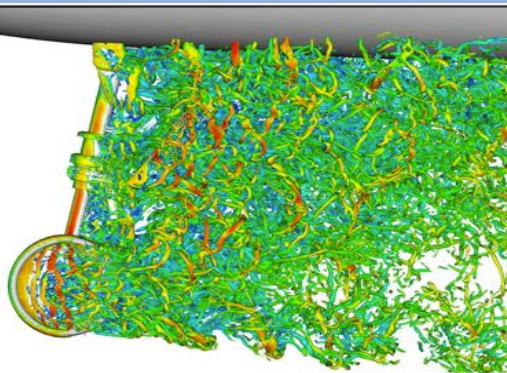

Landing Gear (NS)

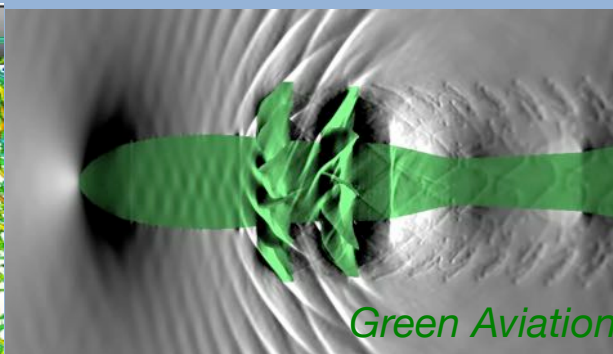

Contra-rotating Open Rotor

Shape Optimization and Design

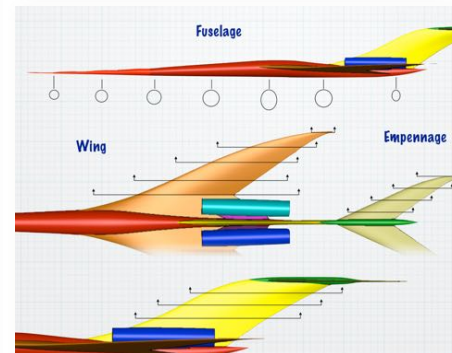

LAVA Computational Grid Paradigms

Structured Cartesian AMR

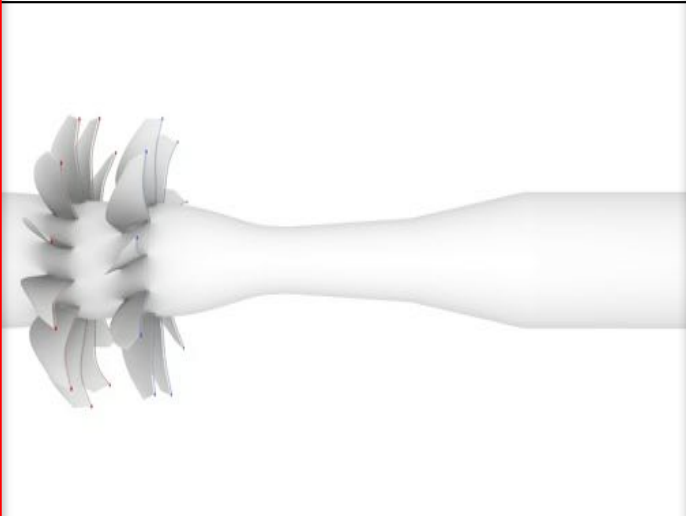
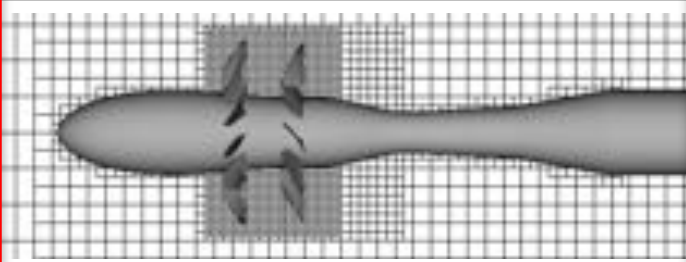

- Essentially no manual grid generation
- Highly efficient Structured
- Adaptive Mesh Refinement (AMR)
- Low computational cost
- Reliable higher order methods
- **Non-body fitted -> Resolution of boundary layers inefficient**

Unstructured Arbitrary Polyhedral

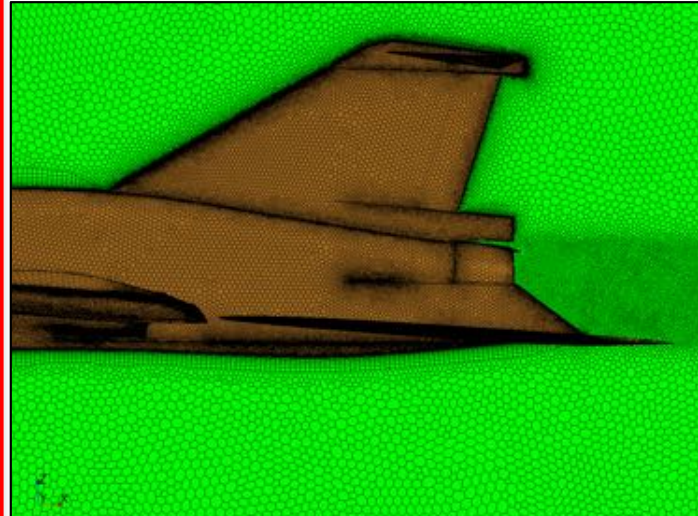
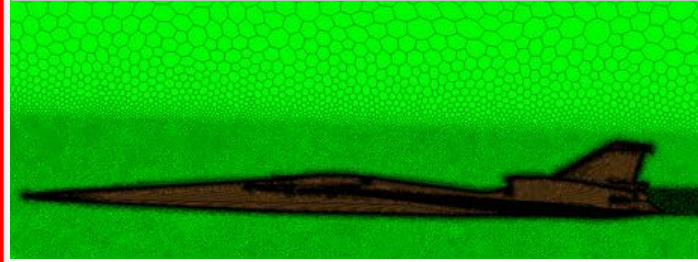

- Partially automated grid generation
- Body fitted grids
- **Grid quality can be challenging**
- **High computational cost**
- **Higher order methods yet to fully mature**

Structured Curvilinear

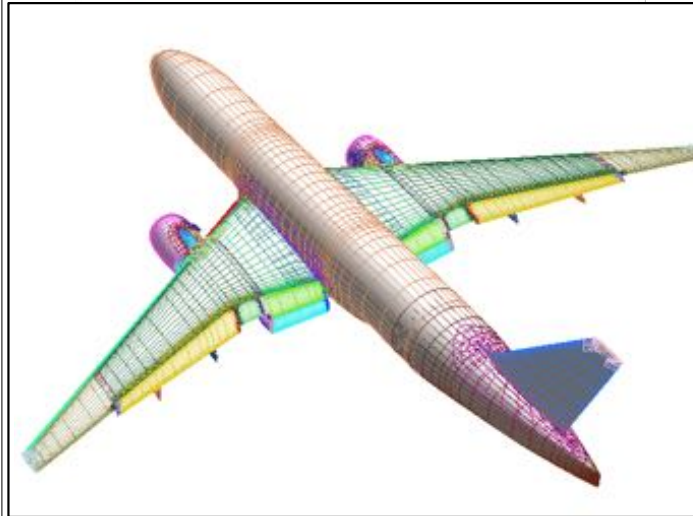
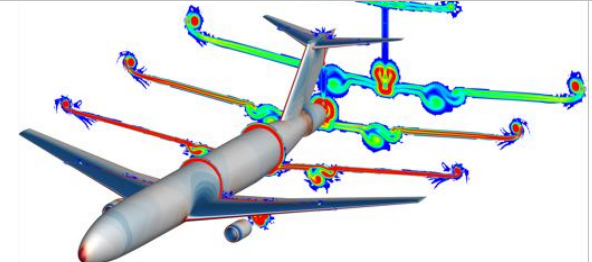

- High quality body fitted grids
- Low computational cost
- Reliable higher order methods
- **Grid generation largely manual and time consuming**

LAVA Framework

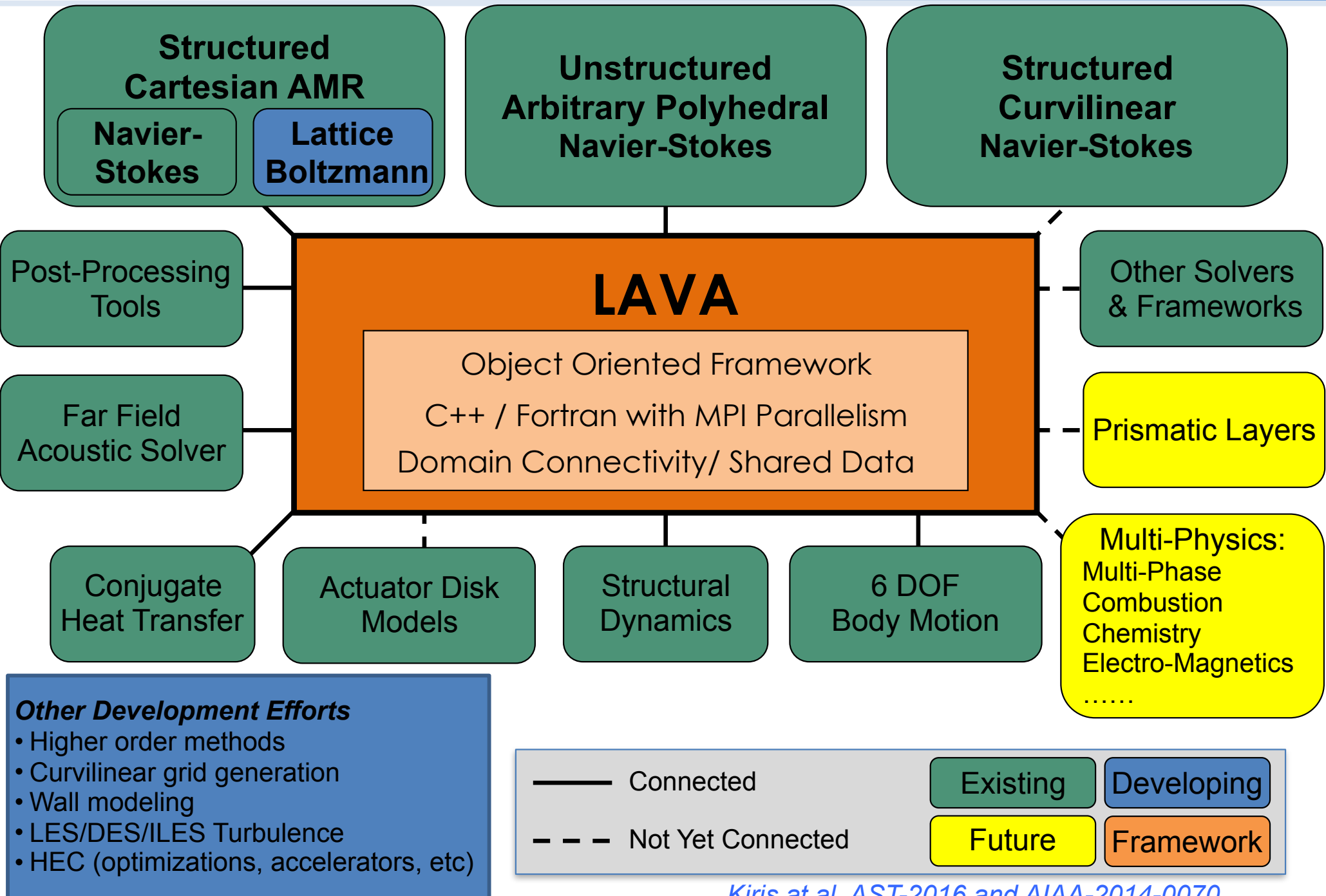



✓ **Computational Grid Paradigms**

- Structured Cartesian, Unstructured Polyhedrals, Structured Curvilinear; each paradigm has its own pros and cons.
- LAVA framework demonstrated quick-analysis capabilities using Cartesian Navier-Stokes solver for acoustics problems with complicated geometries, e.g.;
 - Landing gear
 - Open-Rotor acoustics
 - ERA Broadband Engine Noise Simulator
 - SOFIA Cavity
 - Launch Environment: Ignition Overpressure and Launch Acoustics

✓ **Computational Requirements**

- Space-Time resolution requirements for acoustics problems are demanding.
- LAVA Cartesian infrastructure has been re-factored into Navier-Stokes (NS) and Lattice Boltzman Method (LBM).
 - ~10-50 times speed-up can be achieved with LBM vs NS.
 - Existing LAVA Cartesian data structures and algorithms are utilized to reduce implementation effort.

LAVA LBM: Progress

IMPLEMENTATION TO DATE:

- **Lattices:** including D2Q9, D3Q15, D3Q19, D3Q27, D3Q39 ...
- **Collision Models:**
 - Bhatnagar-Gross-Krook (BGK)
 - Multi-Relaxation Time (MRT)
 - Entropic and positivity preserving variants of BGK
 - Entropic Multi-Relaxation Time
 - Regularized BGK
- **LES Model:** Smagorinsky sub-grid-scale
- **Wall Model:** Filter-based slip wall model
- **Parallelization:**
 - Structured adaptive mesh refinement (AMR) based LBM requires parallel ghost cell exchanges:
 - fine-fine for communication within levels
 - coarse-fine for communication across levels
 - Efficient parallel I/O
- **Multi-Resolution with Recursive Sub-Cycling**
- **Boundary Conditions:**
 - Bounce back wall boundary conditions
 - Inflow/outflow, and periodic
 - Accurate and robust curved wall boundary conditions

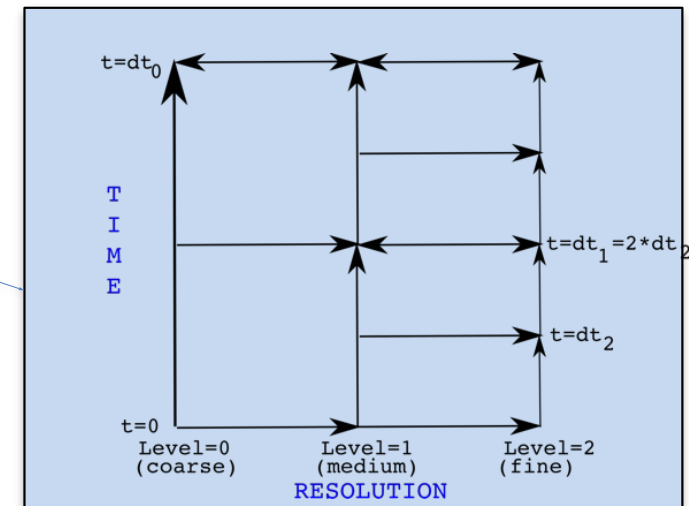
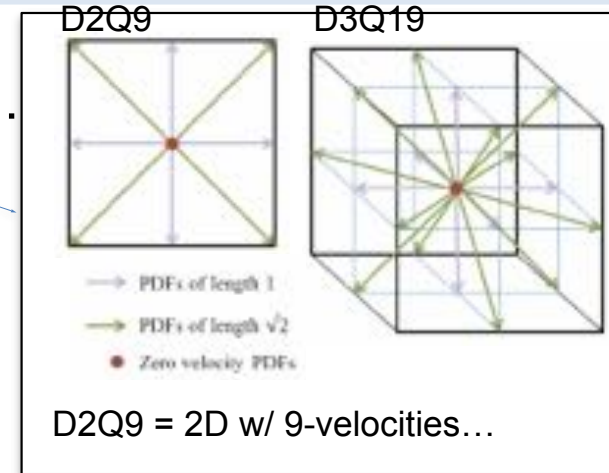

LAVA LBM: Governing Equations



$$\underbrace{f_i(\vec{x} + c\vec{e}_i\Delta t, t + \Delta t) - f_i(\vec{x}, t)}_{\text{Streaming}} = \frac{1}{\tau} \underbrace{(f_i(\vec{x}, t) - f_i^{eq}(\vec{x}, t))}_{\text{Collision}}$$

- **Physics:**

- Governs space time evolution of Density Distribution Functions
- Equilibrium distribution functions are truncated Maxwell-Boltzmann distributions
- Relaxation time related to kinematic viscosity
- Pressure related to density through the isothermal ideal gas law
- **Lattice Boltzmann Equations (LBE) recover the Navier-Stokes equations in the low Mach number limit**

- **Numerics:**

- **Extremely efficient** ‘collide at nodes and stream along links’ discrete analog to the Boltzmann equation
- Particles bound to a regularly spaced lattice collide at nodes relaxing towards the local equilibrium (RHS)
- Post-collision distribution functions hop on to neighboring nodes along the lattice links (LHS) – Exact, dissipation-free advection from simple ‘copy’ operation
- Macroscopic quantities such as density and momentum are moments of the density distribution functions in the discrete velocity space

LAVA LBM: Wall Model

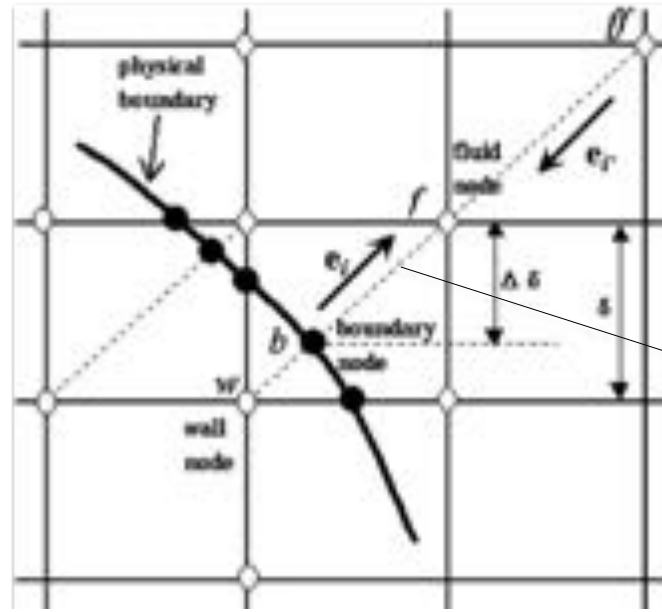

Broken links query surface triangulation for local slip/penetration velocity or wall shear stress computed dynamically by the wall model

- Accurate wall models are critical for Cartesian-grid approaches such as LBM
- **Filter-based slip wall model:** Follows the approach of Bose and Moin (POF, 2014). Adapted for LAVA LBM through a generalized slip algorithm. Traditional wall models based on law-of-the-wall hard to justify for the landing gear noise simulation. Reynolds number is too low. Subcritical separation from wheels expected.
- **Traditional equilibrium and non-equilibrium wall models** (In progress): Follows the approach of Kawai and Larsson (POF, 2012) and Yang et al. (POF, 2015). Rules that express unknown incoming populations in terms of known outgoing populations modified to enforce momentum flux computed by the wall model.

LAVA LBM: Embedded Geometry

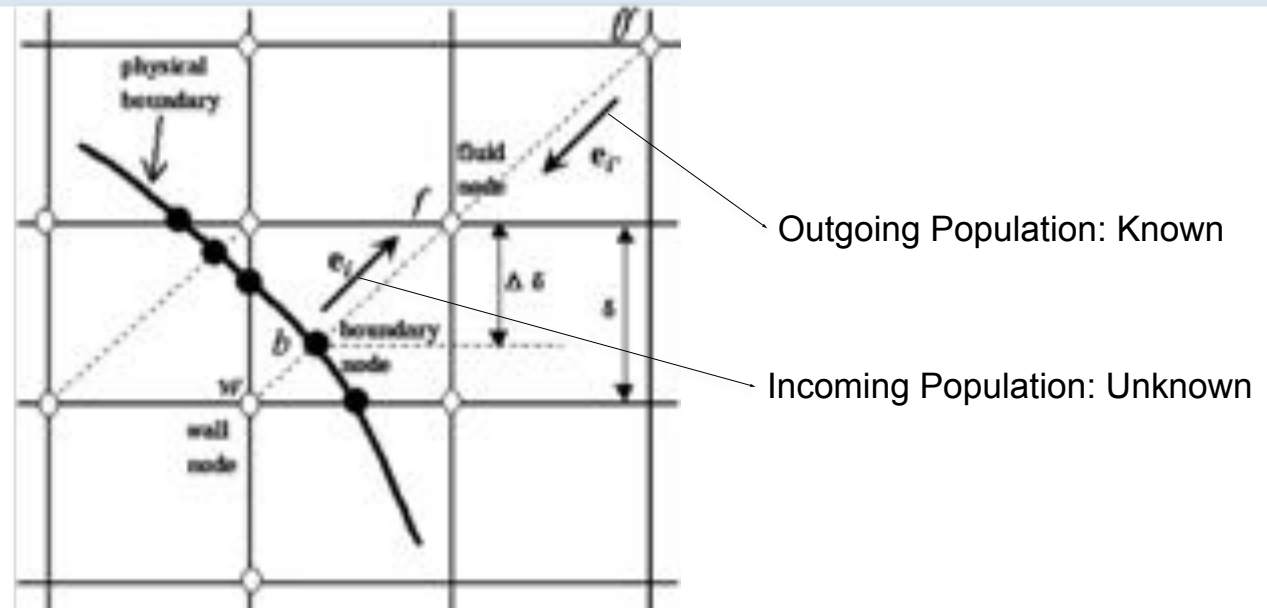

- Boundary conditions in LBM are simple rules that relate ‘incoming’ populations to ‘outgoing’ populations for lattice links intercepted by an embedded surface
- **Standard Bounce Back (SBB)**: ‘Bounce-back’ rule realizes the no-slip boundary condition, but approximates the curved geometry by a series of small steps.
- **Linear Bounce Back (LBB)**: Interpolated no-slip bounce-back rules (cf. Bouzidi et al. (POF, 01)) capture the curvature in geometry more accurately. Improved prediction of surface pressure fluctuations, critical for accurate acoustic predictions.
- **Halfway Bounce Back (HBB)** rule of A. C. Ladd (JFM, 94) generalized to be second-order accurate for arbitrary geometry (stationary and moving) and adapted for wall models using a generalized slip algorithm for realizing the appropriate momentum exchange.

LAVA LBM: Verification and Validation

LES OF FLOW PAST A CYLINDER

- Well documented prototypical turbulent separated flow
- Detailed comparisons made with measurements and benchmark simulations
- **Setup:** Reynolds number = 3900
- **Comparisons:**
 - LBM at 1M and 8M compares well with DNS @ 400M (M = million points)
 - 20x speedup even with embedded geometry:
 - Excellent comparison with benchmark datasets (PIV, LES, DNS). DNS reference used $Re=3300$.
 - More accurate than high-order upwind biased NS schemes for identical resolution

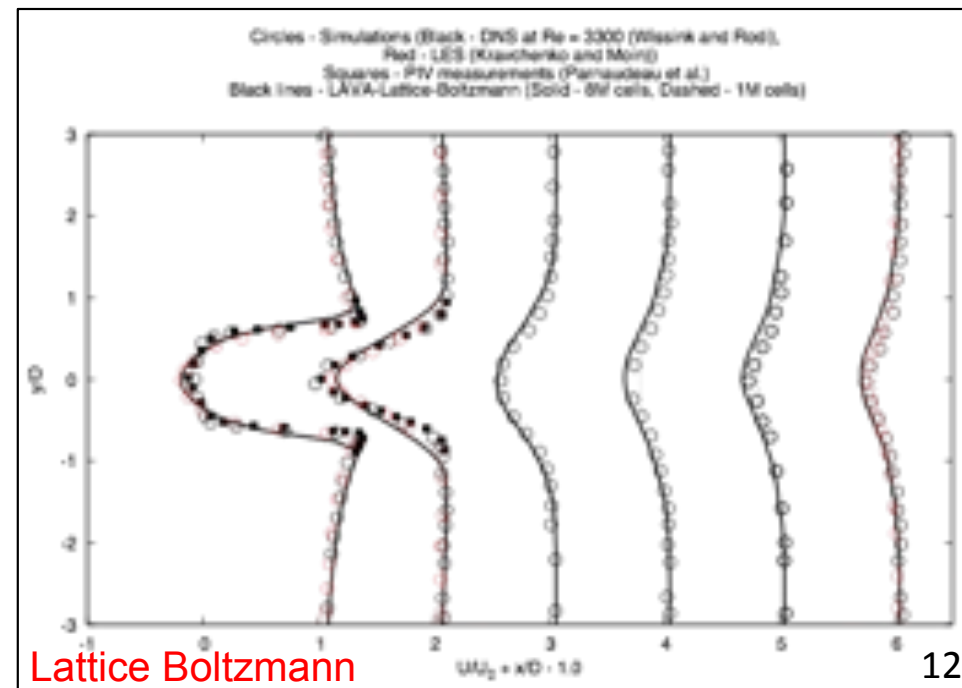
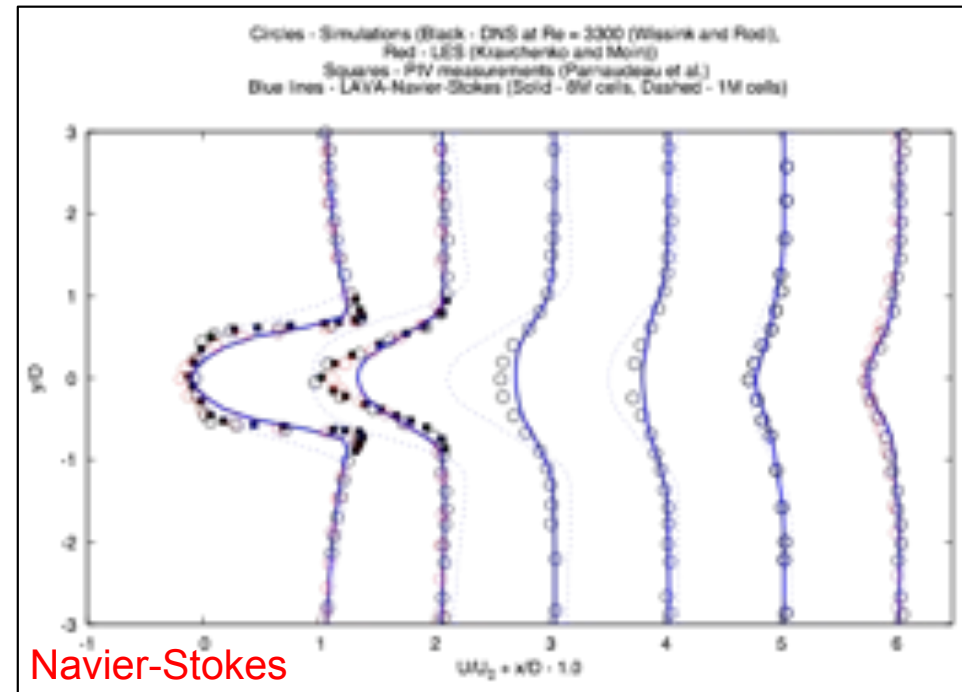

Cavity-Closed Nose Landing Gear

Grid Topology and Computational Setup

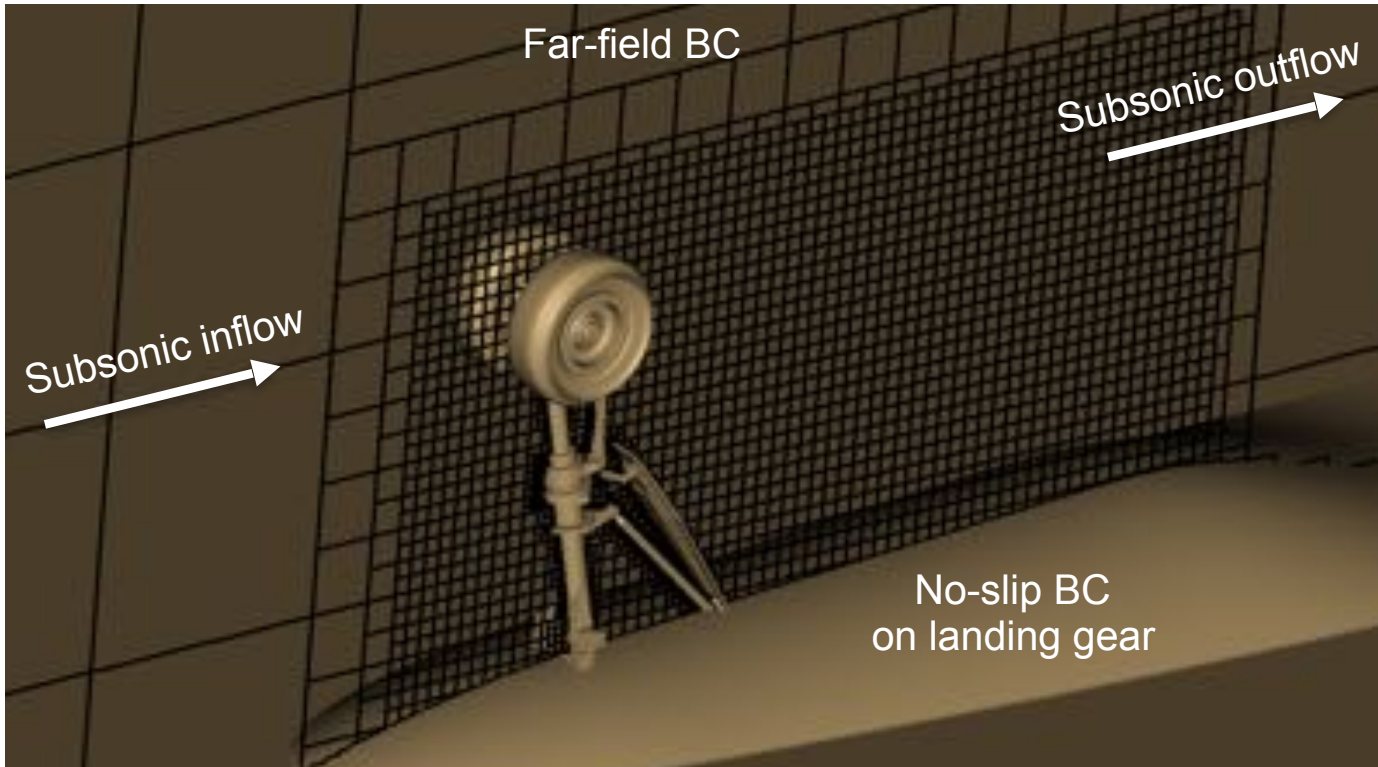

$Mach = 0.166$
 $Re = 66423 (D=D_{strut})$
 $U_{ref} = 58.32 \text{ m/s}$
 $T_{ref} = 307.05 \text{ K}$
 $P_{ref} = 98605 \text{ Pa}$

Setup follows the partially-dressed, cavity-closed nose landing gear (PDCC-NLG) noise problem from [AIAA's Benchmark problems for Airframe Noise Computations \(BANC\) series of workshops](#). (Problem 4. [Nose landing gear](#): POC: Mehdi R. Khorrami)

https://info.aiaa.org/tac/ASG/FDTC/DG/BECAN_files/_BANCIII.htm?_ga=1.138948979.1114116691.1491921988

Grid Visualization

9 Levels (56M)

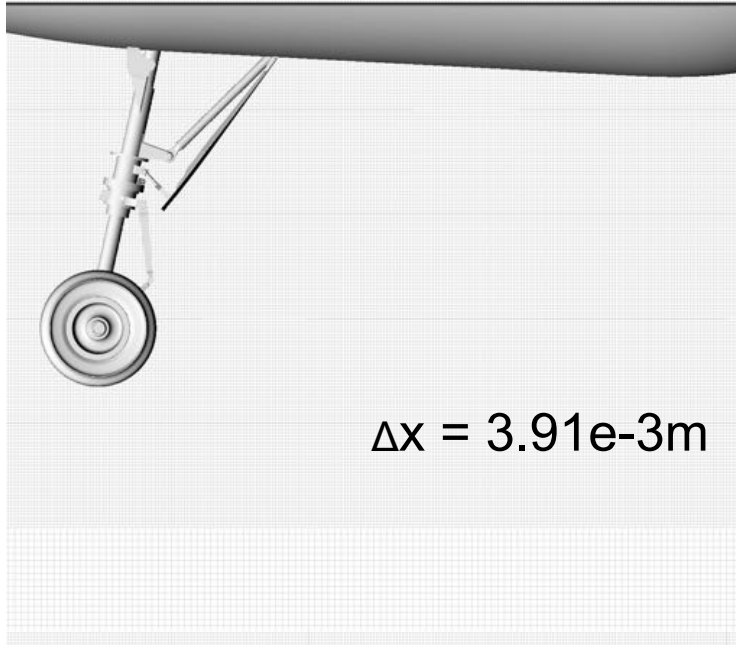

10 Levels (91 M)

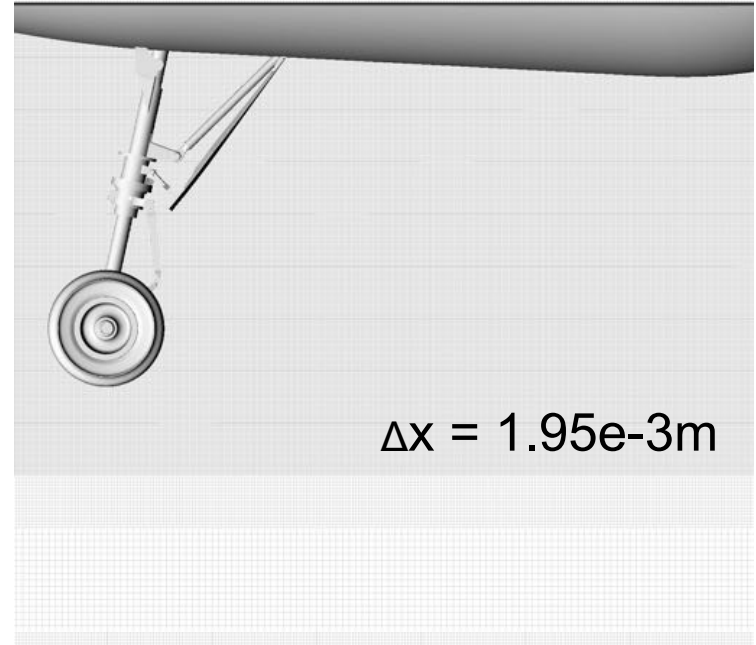

11 Levels (260M)

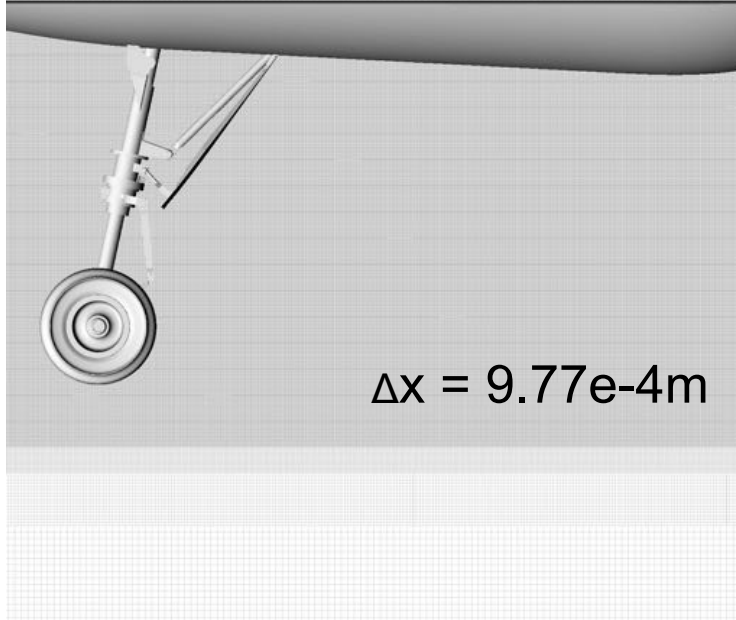

12 Levels (1.6B)

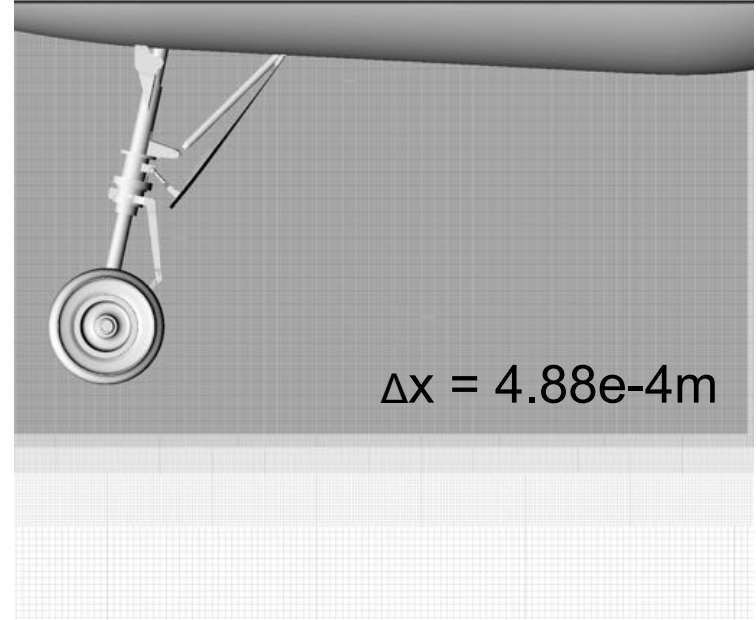

Grid Sensitivity: Vorticity @ 10000 [1/s]

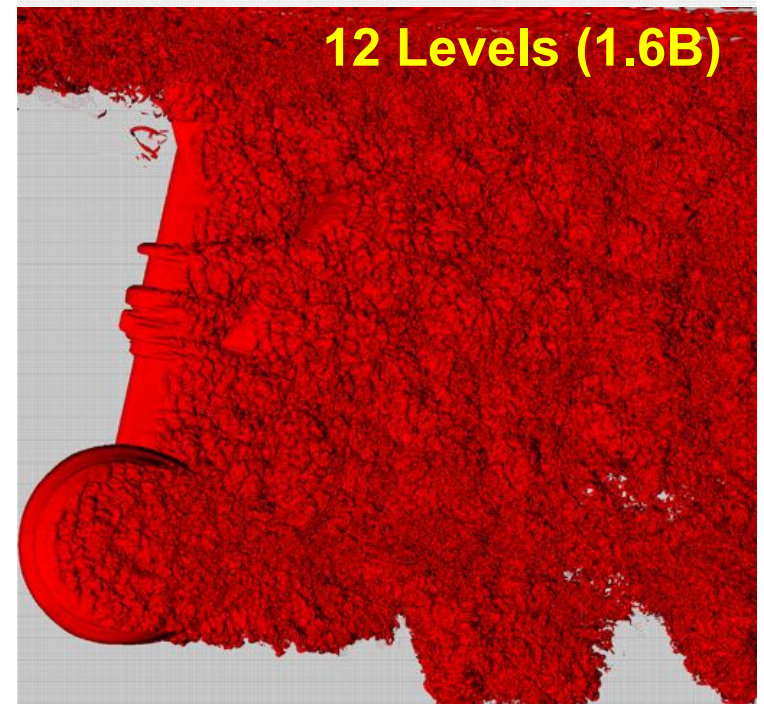
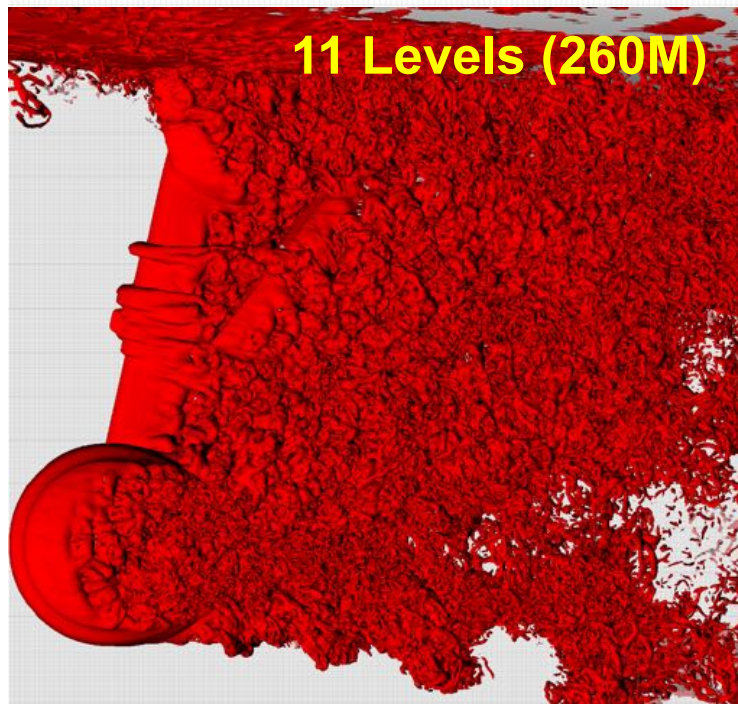
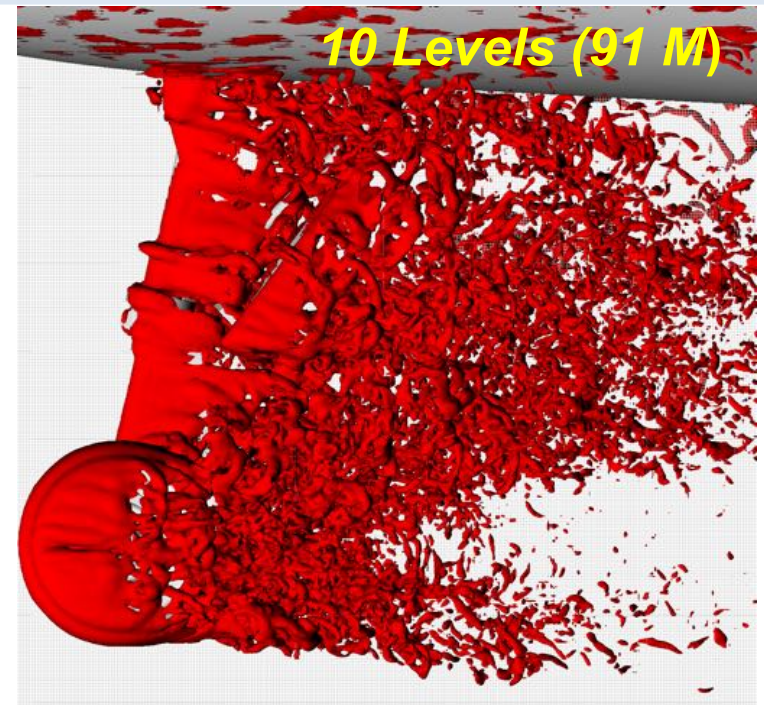

Grid Sensitivity: Vorticity Colored by Mach

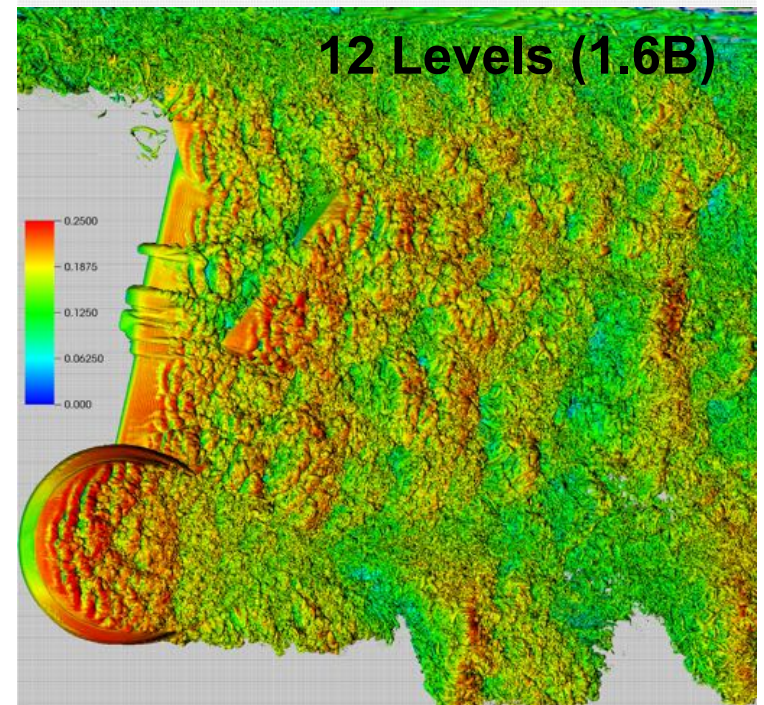
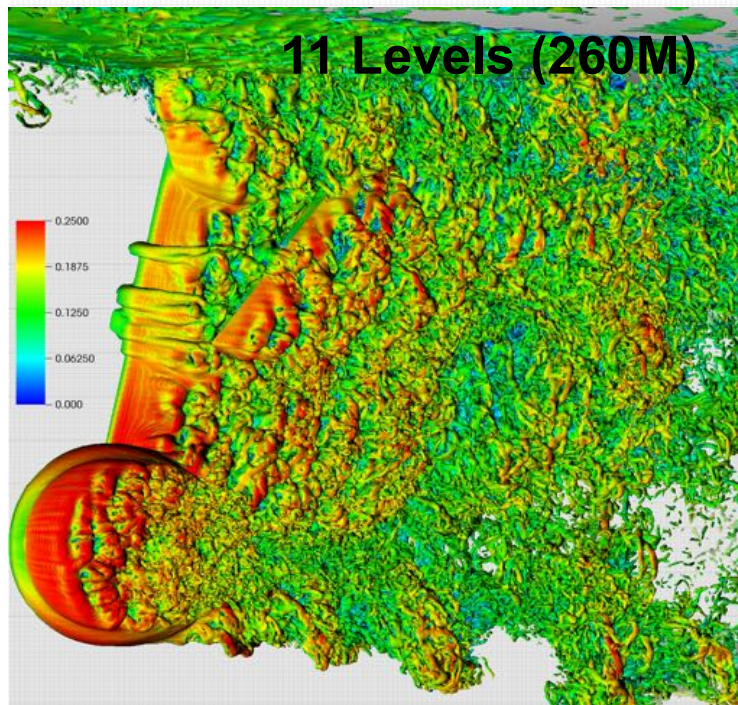
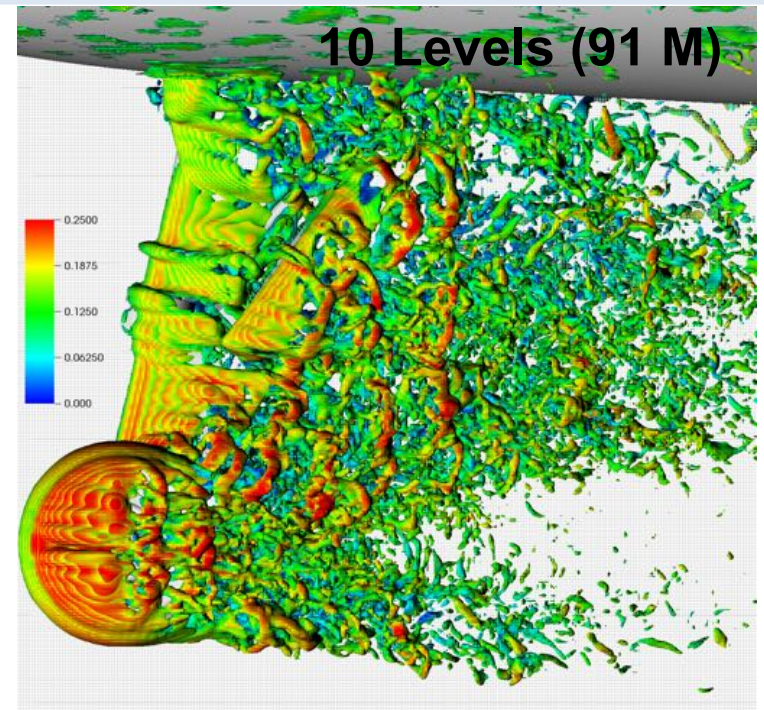
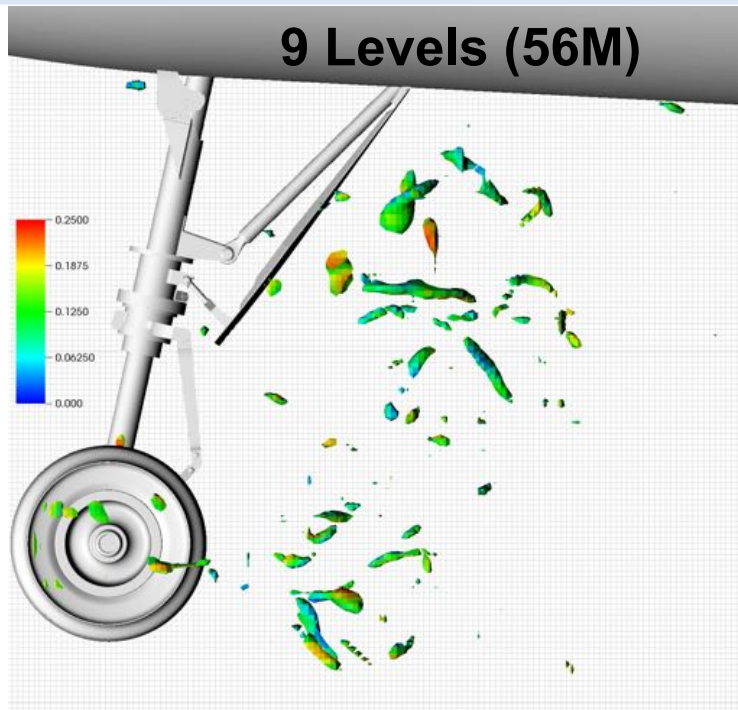

Vorticity Colored by Mach Number

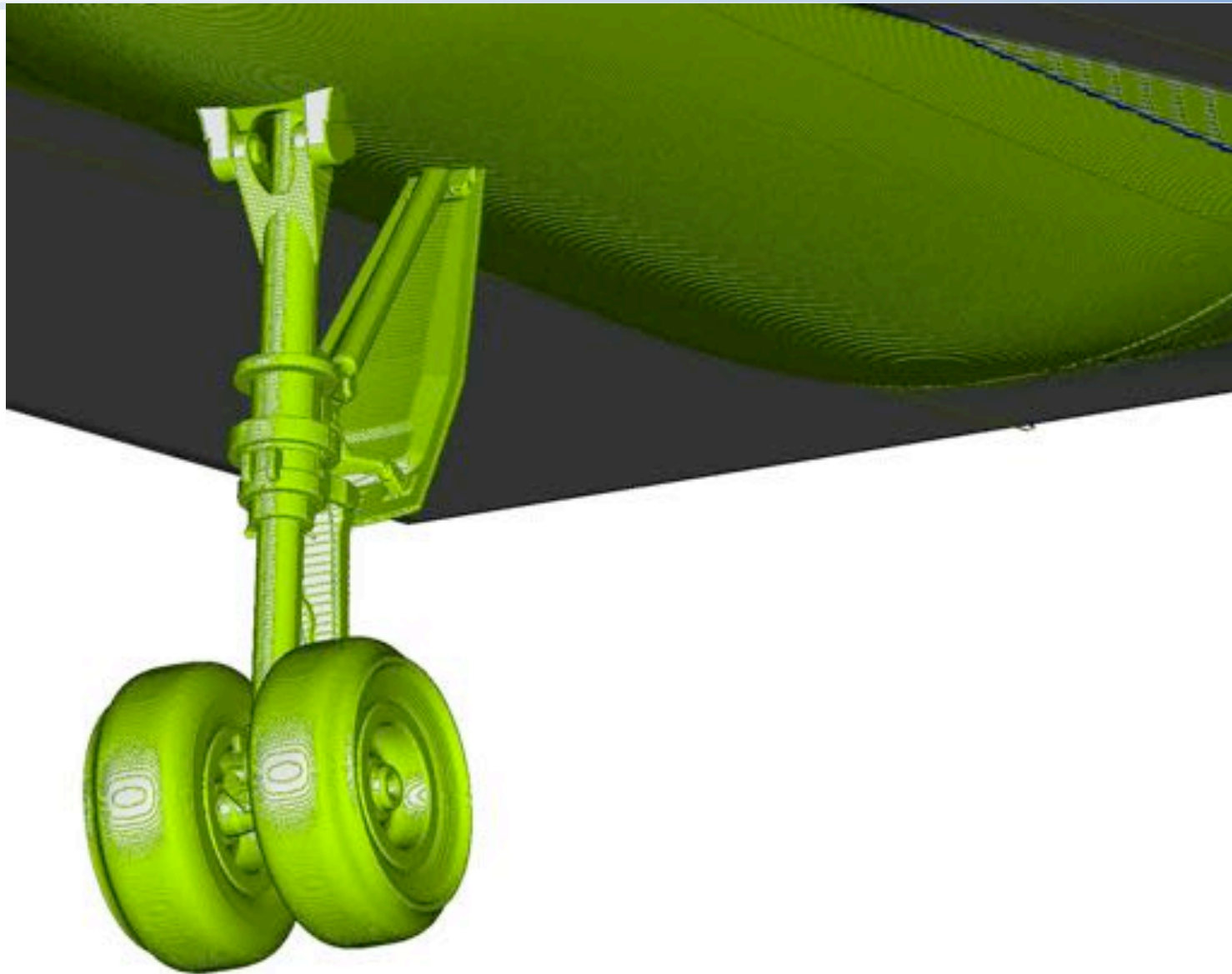

Velocity Magnitude (Center-plane)

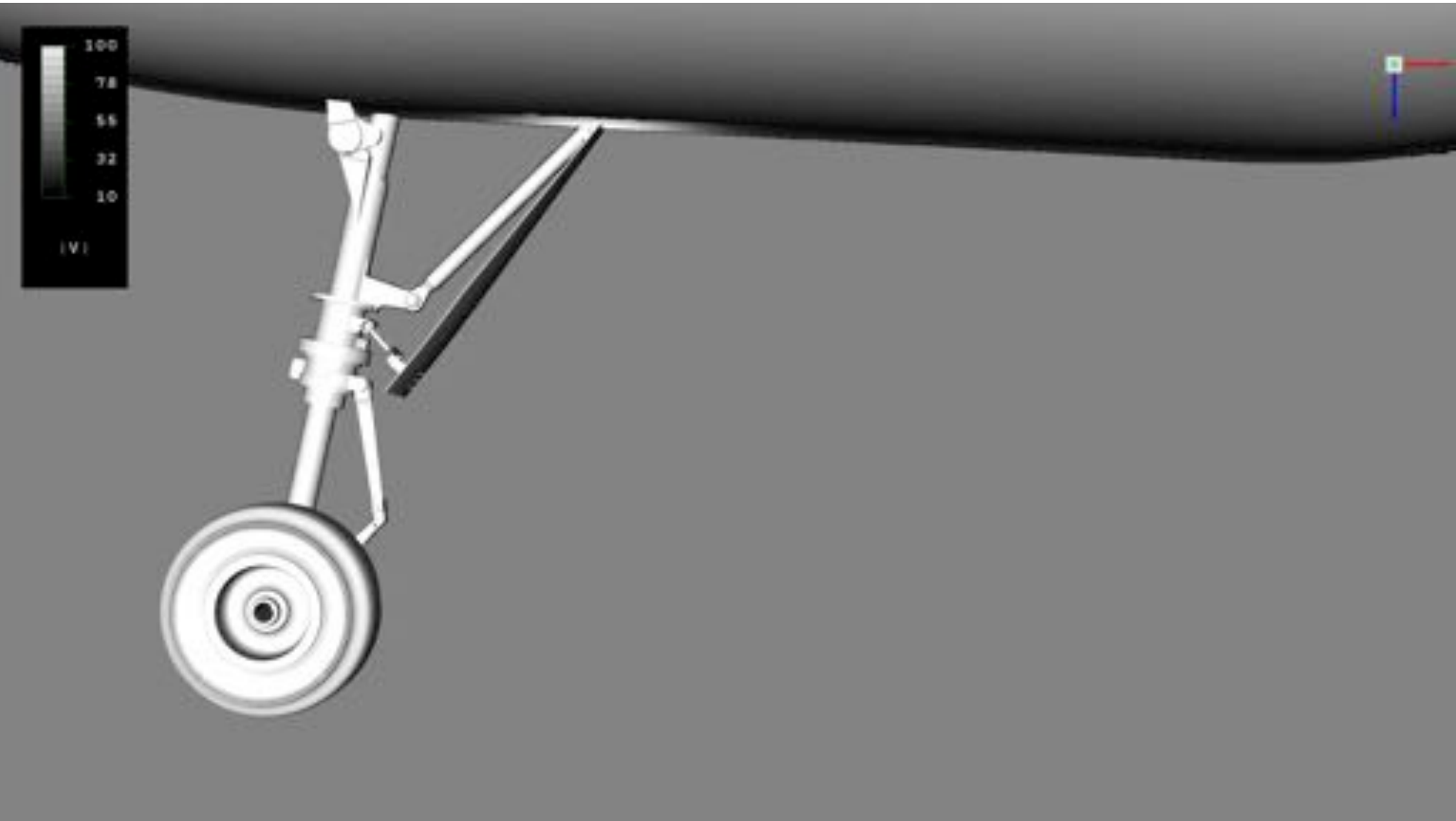

Passive Particle Colored by Mach



Grid Sensitivity - PSD

Channel 4

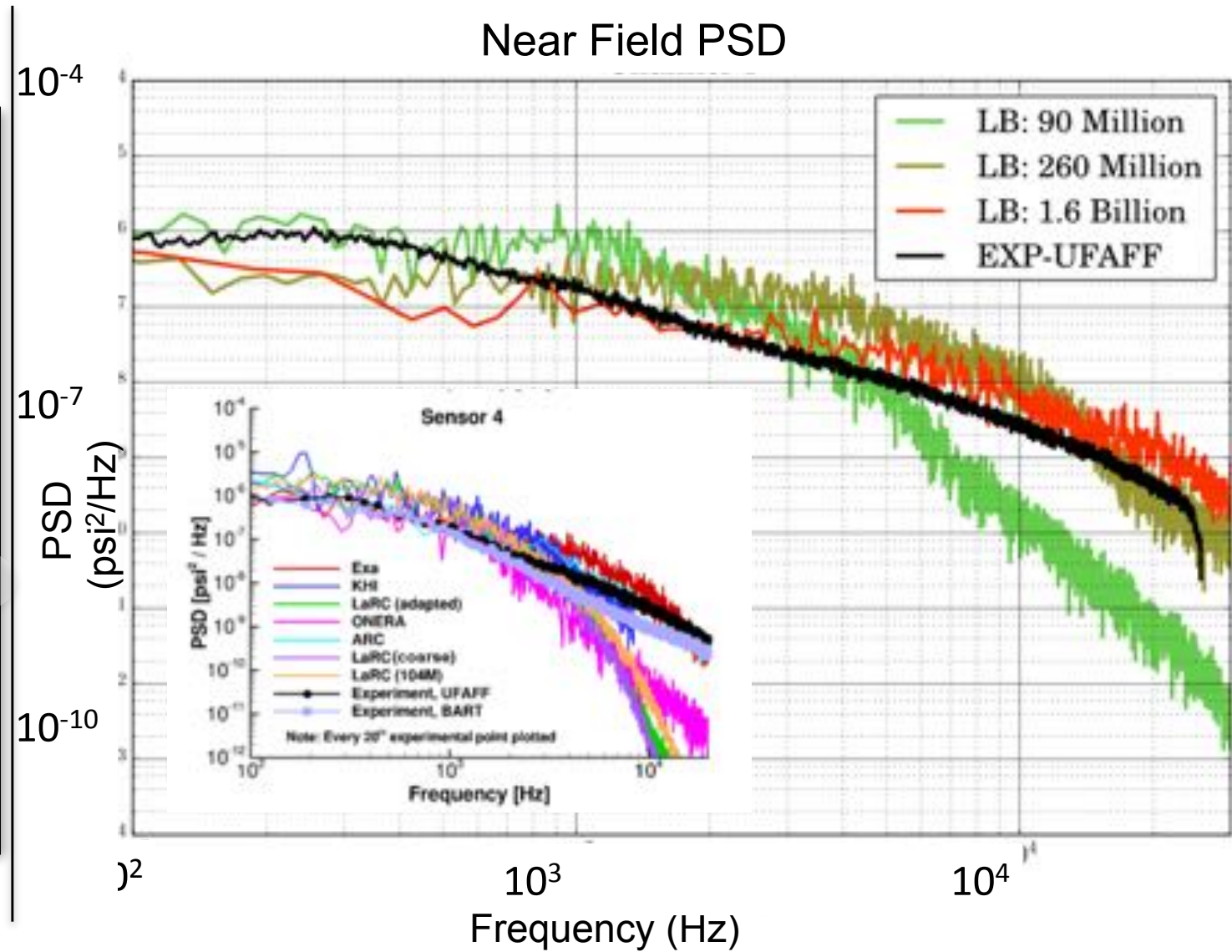
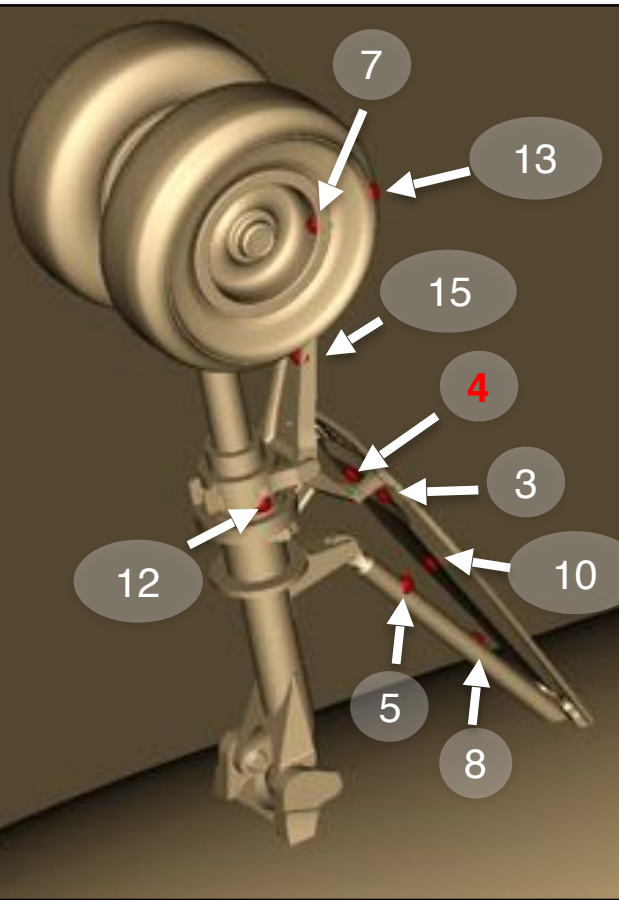

Grid Sensitivity - PSD

Channel 5

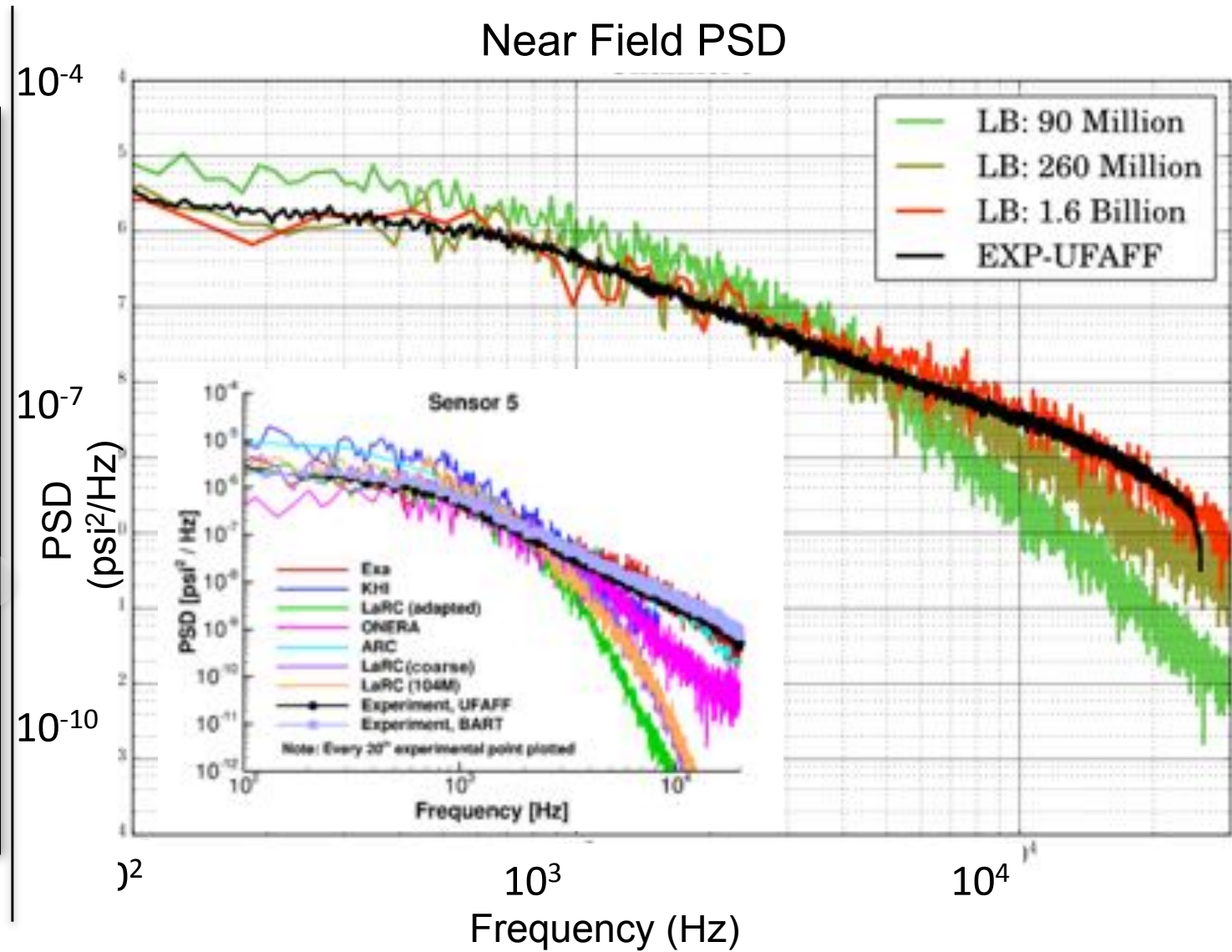
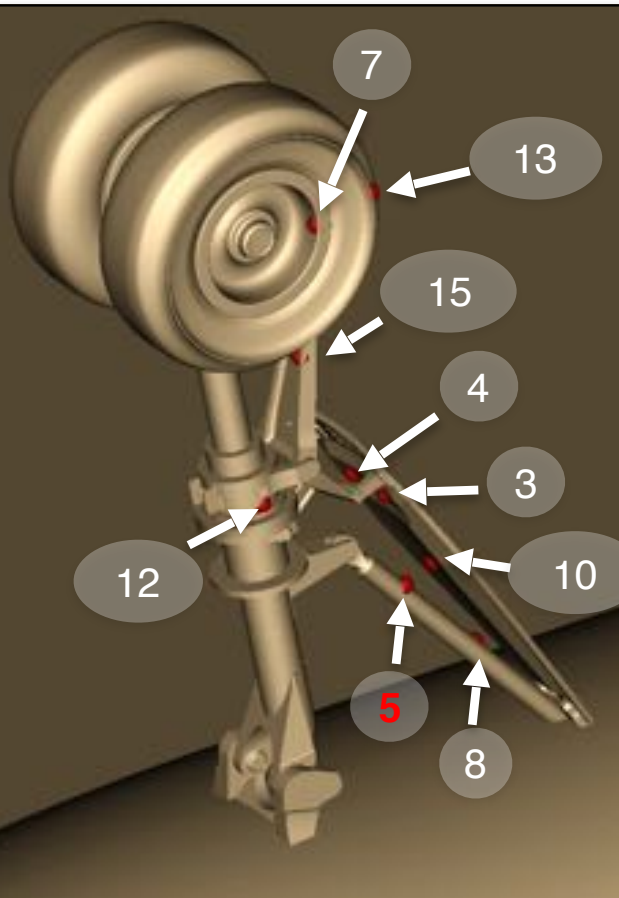

Grid Sensitivity - PSD

Channel 13

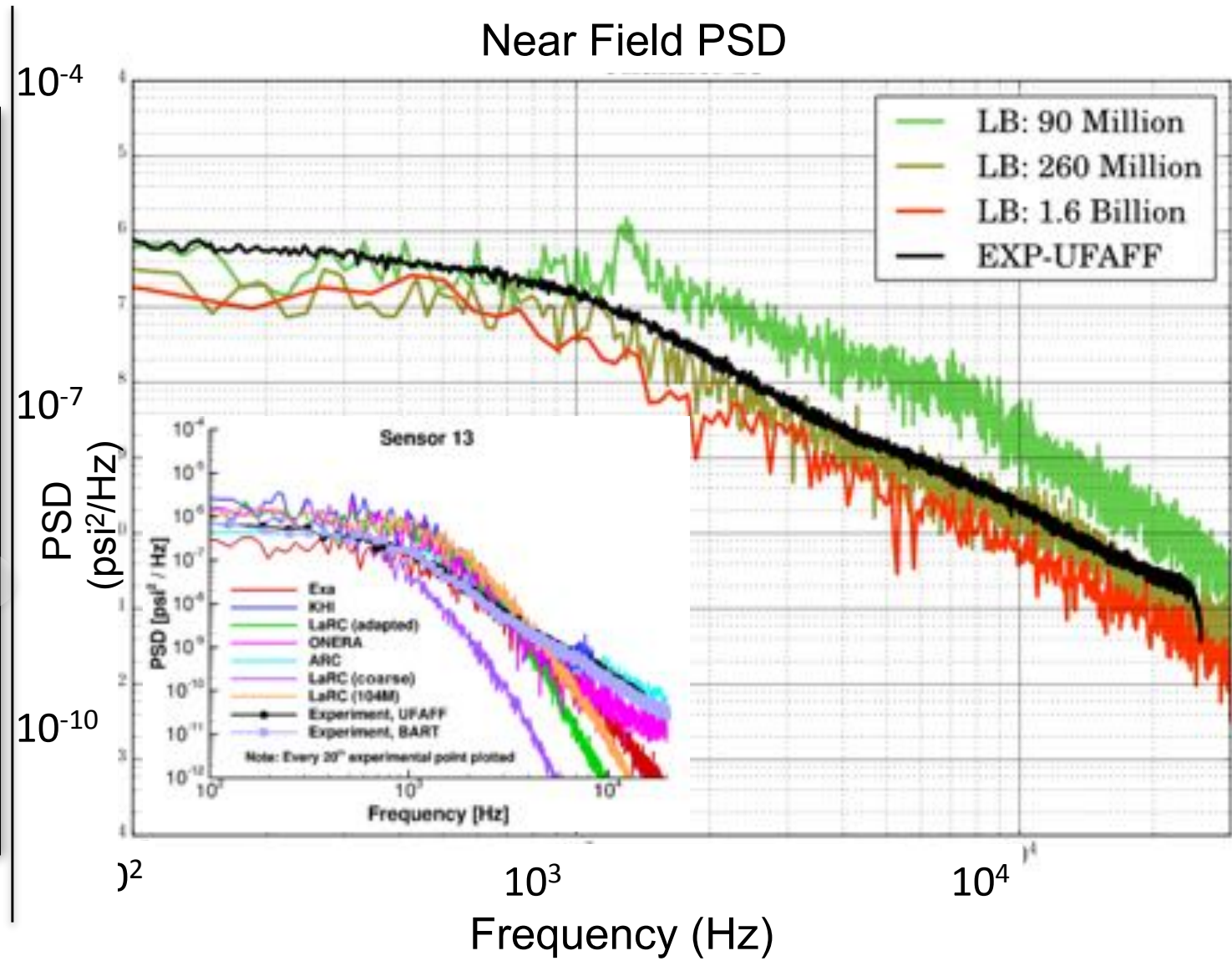
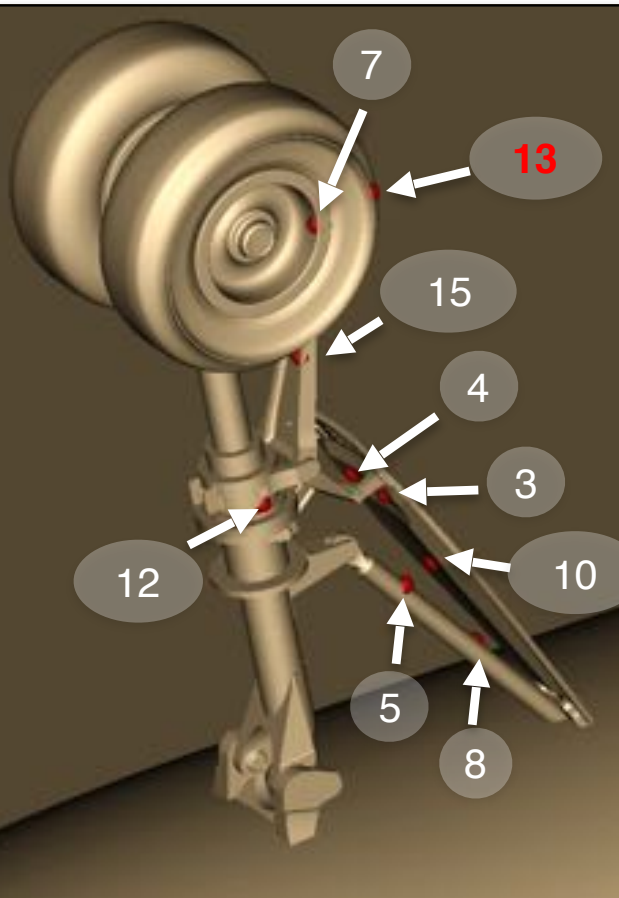

10⁻¹³

Boundary Scheme Sensitivity - PSD

Channel 5

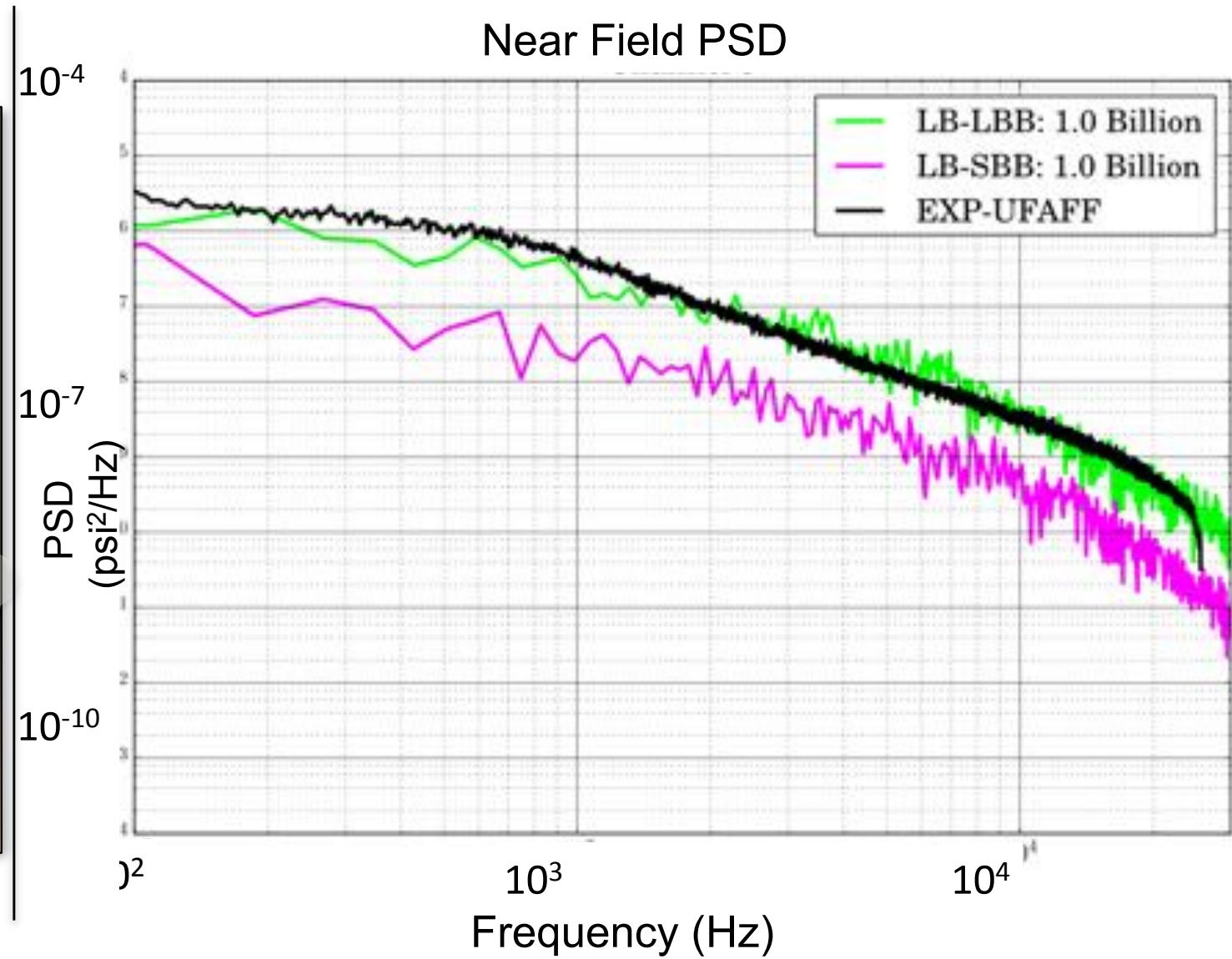
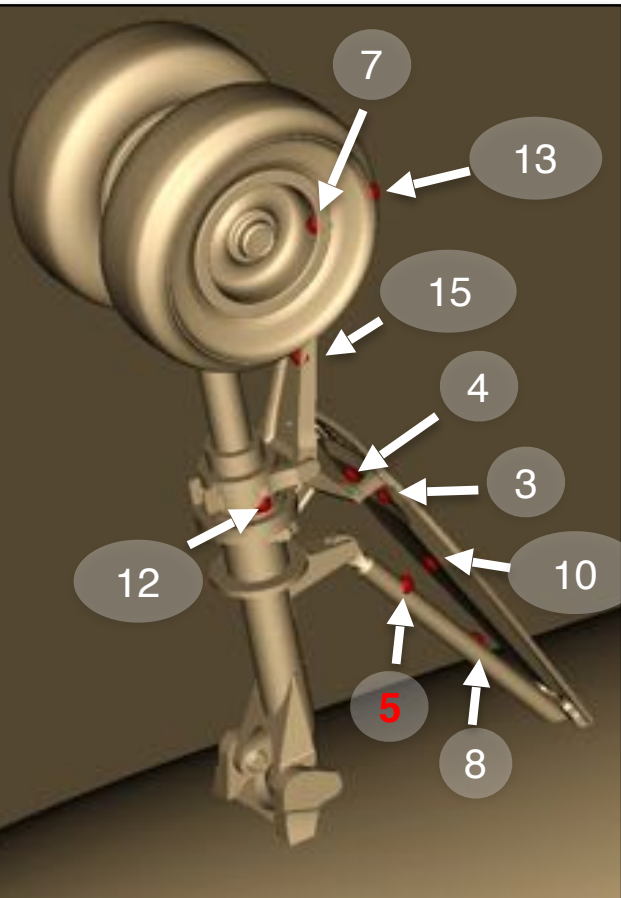

LBM vs NS - PSD

Channel 5

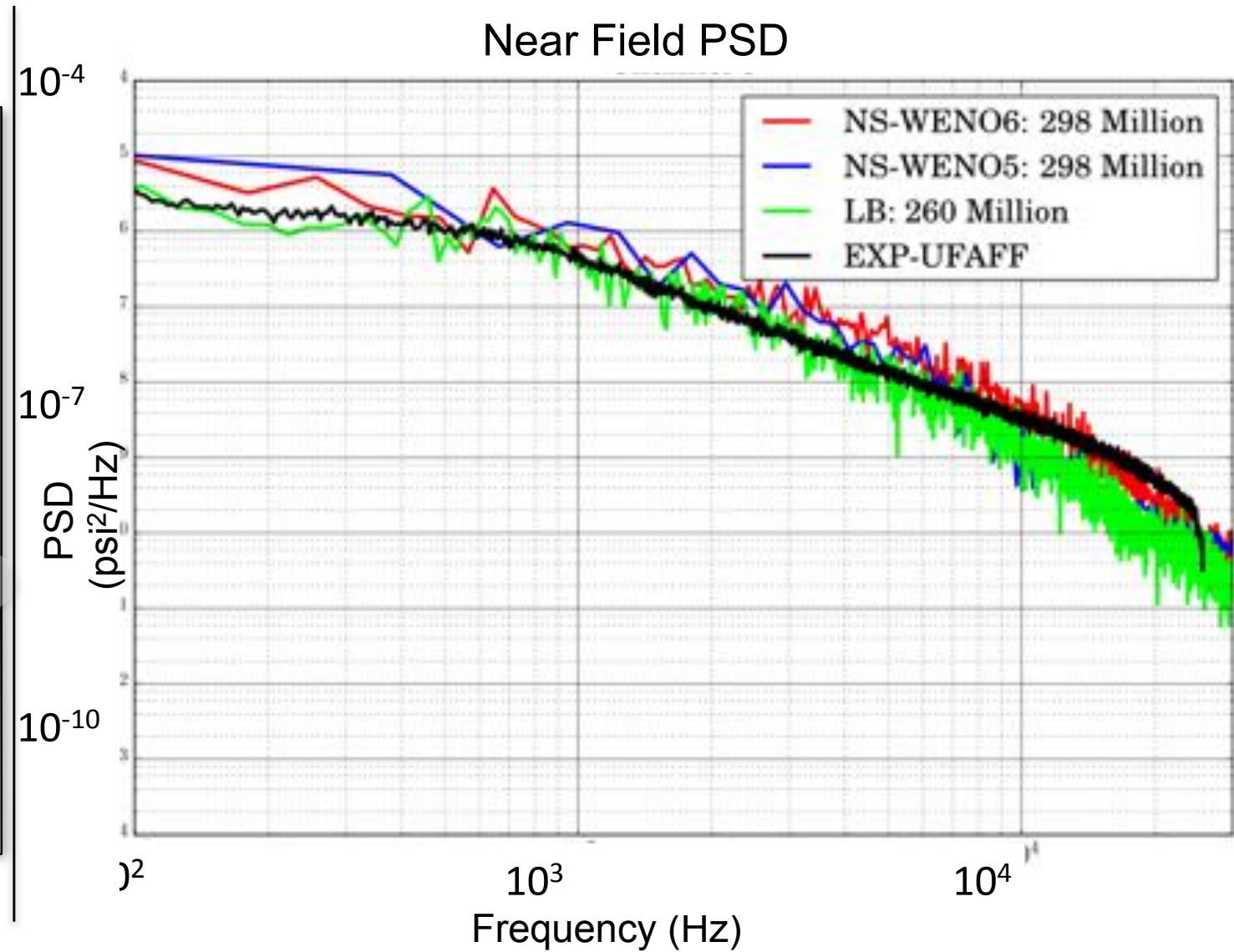
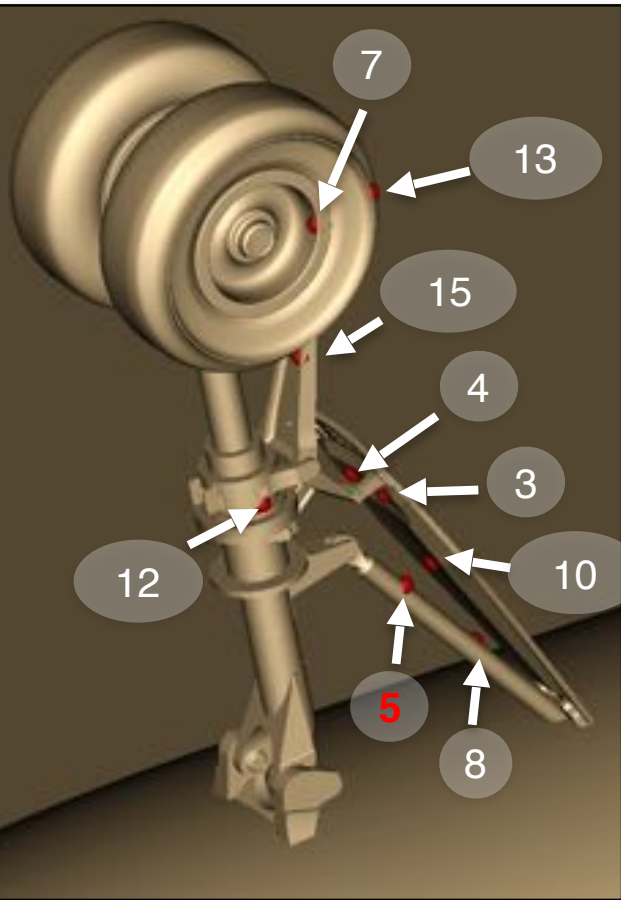

LBM vs NS - PSD

Channel 13

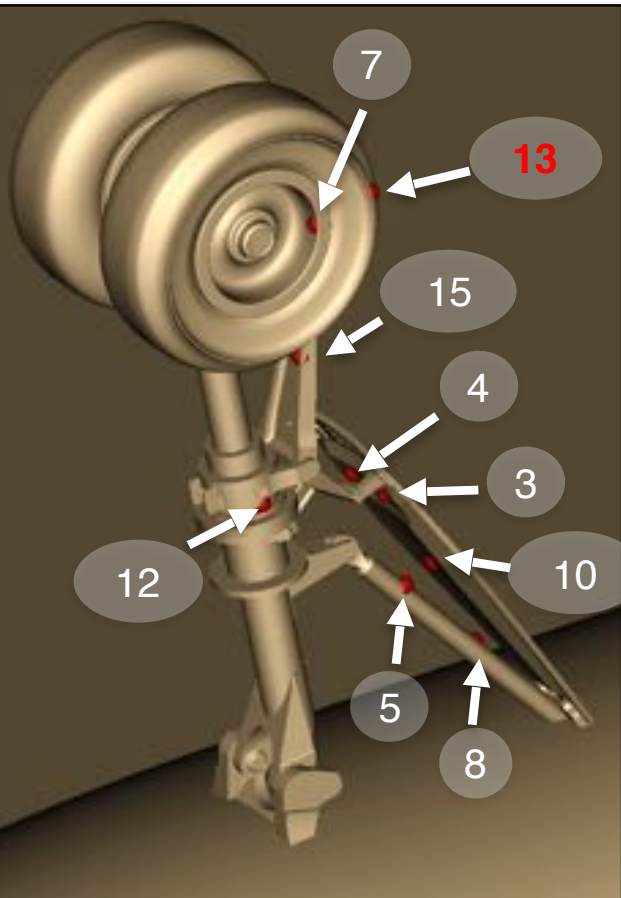

Near Field PSD

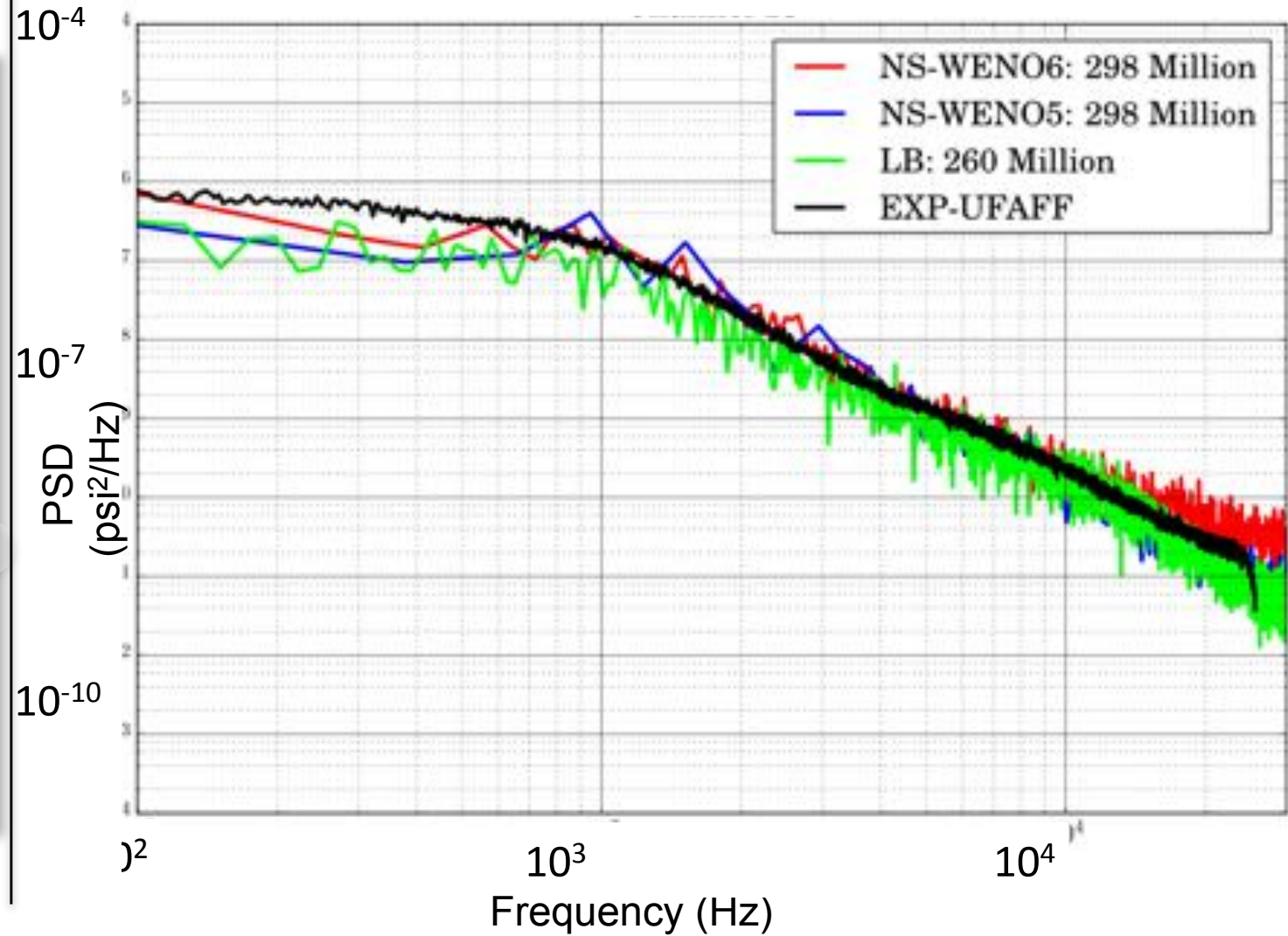

10⁻¹³



Grid and Performance Statistics

Method	CPU Cores (type*)	Cells (million)	Wall Days to 0.19 sec	Core Days to 0.19 sec	Relative SBU Expense
NS-GCM	3000 (ivy)	298	20.5	61352	12.1
NS-IIM	9600 (has)	222	6.1	58490	15.3
LBM	1400 (bro)	260	2.25	3156	1

- For a comparable mesh size, **LBM is 15 times faster (in CPU utilization) than Navier-Stokes** with a higher order immersed boundary, and is **equally accurate**. (LBM code is not yet optimized!)
- LBM at 1.6 billion cells is ~2 times faster than NS at 298 million. This is a key enabler for unprecedented high resolution simulations.

Summary

- Demonstrated the LBM approach on the AIAA BANC III Workshop Landing Gear problem IV.
 - Computed results compare well with the experimental data
 - 20 times speed-up was observed between LBM and NS calculations.
- LBM has significantly lower floating point operations relative to WENO+RK4
- LBM has minimal numerical dissipation

Next Steps

- Continue Verification & Validation efforts
- Improve wall modeling for arbitrarily complex geometry at high Reynolds numbers
- Moving geometry capability
- High speed flows
- Further performance optimizations: excellent data locality, vectorizable, scalable.

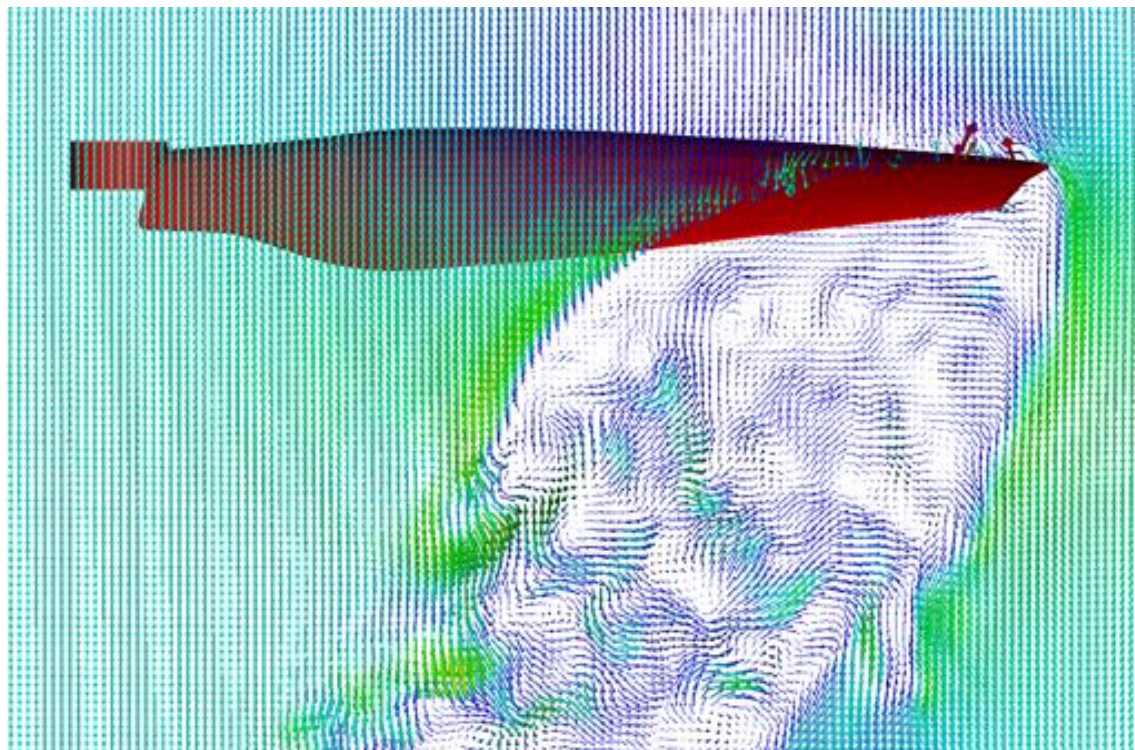

LBM moving geometry formulation (in progress)

Questions ?

