



# IEEE NSREC Short Course Session I

## A Brief History of Space Climatology: From the Big Bang to the Present

Mike Xapsos  
NASA Goddard Space Flight Center

Kona, Hawaii  
July 16, 2018



# Acronyms

- **ACE – Advanced Composition Explorer**
- **AE8/9 – Aerospace Electron Model 8/9**
- **AFRL – Air force Research Laboratory**
- **AP8/9 – Aerospace Proton Model 8/9**
- **CME – Coronal Mass Ejection**
- **CRAND – Cosmic Ray Albedo Neutron Decay**
- **CREDO – Cosmic Radiation Environment Dosimetry and Experiment**
- **CREME96 – Cosmic Ray Effects in Microelectronics 1996**
- **CRRES – Combined Release and Radiation Effects Satellite**
- **DC – Direct Current**
- **ESP – Emission of Solar Protons**
- **GCR – Galactic Cosmic Rays**
- **GEO – Geostationary Earth Orbit**
- **GOES – Geostationary Operational Environmental Satellite**
- **HST – Hubble Space Telescope**
- **IMP-8 – International Monitoring Platform-8**
- **IRENE – International Radiation Environment Near Earth**
- **ISEE-3 – International Sun-Earth Explorer-3**
- **LASCO – Large Angle and Spectrometric Coronagraph**
- **LEO – Low Earth Orbit**
- **LET – Linear Energy Transfer**
- **LIS – Local Interstellar Spectrum**
- **MEO – Medium Earth Orbit**
- **MSU – Moscow State University**
- **NAND – Neither Agree Nor Disagree**
- **NIEL – Non-Ionizing Energy Loss**



# Acronyms (continued)

- **NSREC – Nuclear and Space Radiation Effects Conference**
- **POES – Polar Orbiting Earth Satellite**
- **PSYCHIC – Prediction of Solar Particle Yields for Characterizing Integrated Circuits**
- **rad – radiation absorbed dose**
- **RADECS – Radiation Effects in Components and Systems (Conference)**
- **RDM – Radiation Design Margin**
- **SAPPHIRE – Solar Accumulated and Peak Proton and Heavy Ion Radiation Environment**
- **SDO – Solar Dynamics Observatory**
- **SEB – Single Event Burnout**
- **SEE – Single Event Effects**
- **SEL – Single Event Latchup**
- **SEP – Solar Energetic Particles**
- **SET – Single Event Transient**
- **SEU – Single Event Upset**
- **SOHO – Solar and Heliospheric Observatory**
- **TID – Total Ionizing Dose**
- **TNID – Total Non-Ionizing Dose**
- **TRACE – Transition Region and Coronal Explorer**
- **TSX-5 – Tri-Service-Experiments-5**

# Single Event Effects

- **Single Event Effect – any measureable effect in a circuit caused by a single incident particle**
  - **Non-destructive – single event upset (SEU), single event transient (SET)**
  - **Destructive – single event latch-up (SEL), single event burnout (SEB)**

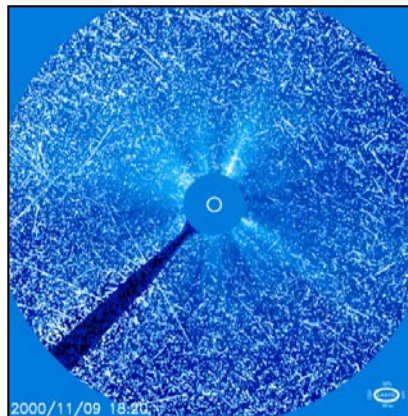

Credit: ESA and NASA (SOHO/LASCO)

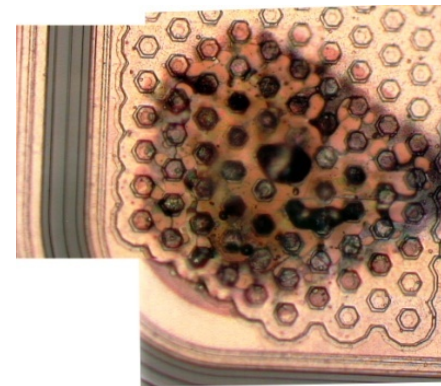

DC-DC Converter

Credit: NASA Electronics Parts & Packaging Program

# Single Event Metric

- **SEE may be caused by direct ionization**
  - Usually the case for incident heavy ions
- **Metric used to calculate single event rates is charge collected in sensitive volume**
  - $Q = C \times LET \times s$ 
    - LET is ionizing energy lost by ion per unit path length
      - Units are MeV/cm or **MeV-cm<sup>2</sup>/mg**
    - s is path length through sensitive volume
- **For some modern devices LET parameter may not be sufficient**

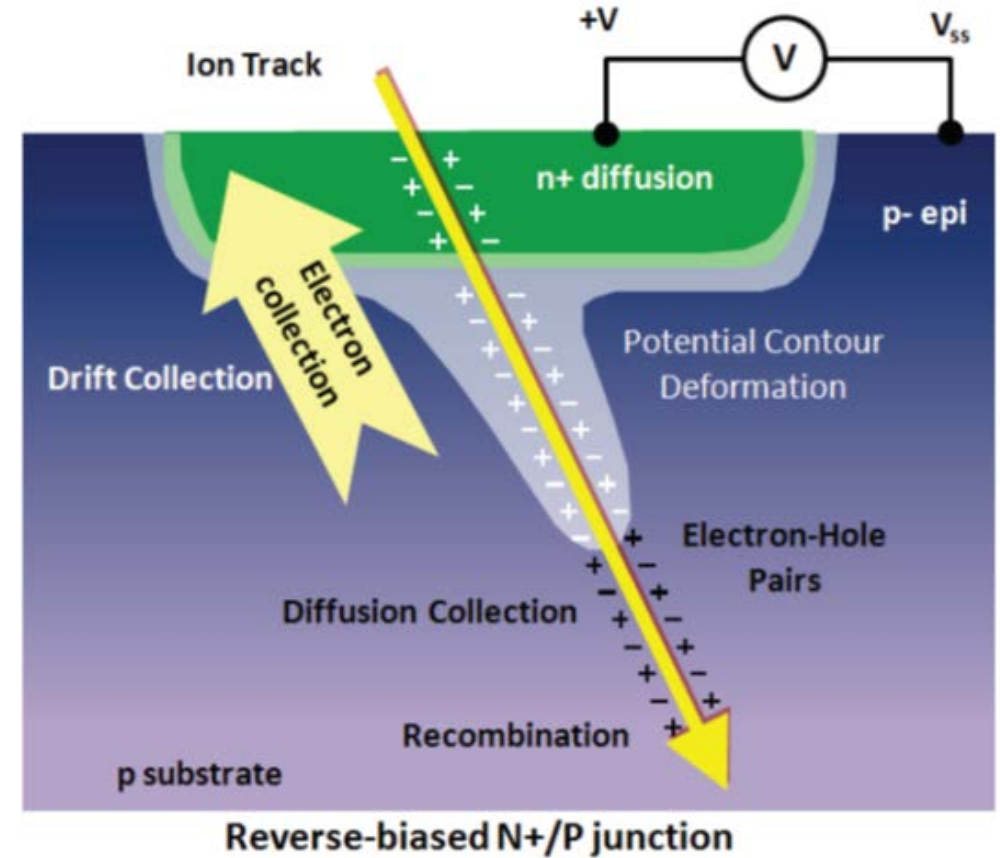

R.C. Baumann, 2013 NSREC Short Course

# Single Event Metric

- **SEE may be caused by nuclear reaction products**
  - Usually the case for incident protons
- **Metric for single event rate is still charge collected in sensitive volume but calculation is more complex**

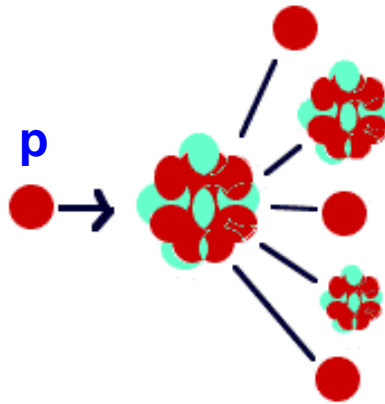

# Total Ionizing Dose

- **Cumulative damage resulting from electron-hole pair production in insulating regions of devices**
- **Causes effects such as:**
  - Threshold voltage shifts
  - Timing skews
  - Leakage currents
- **TID metric = ionizing energy deposited per unit mass of material in sensitive volume**
- **TID = C x LET x Fluence**
  - Fluence in particles/cm<sup>2</sup>
  - 1 Gy = 1 J/kg
  - 1 rad = 100 erg/g

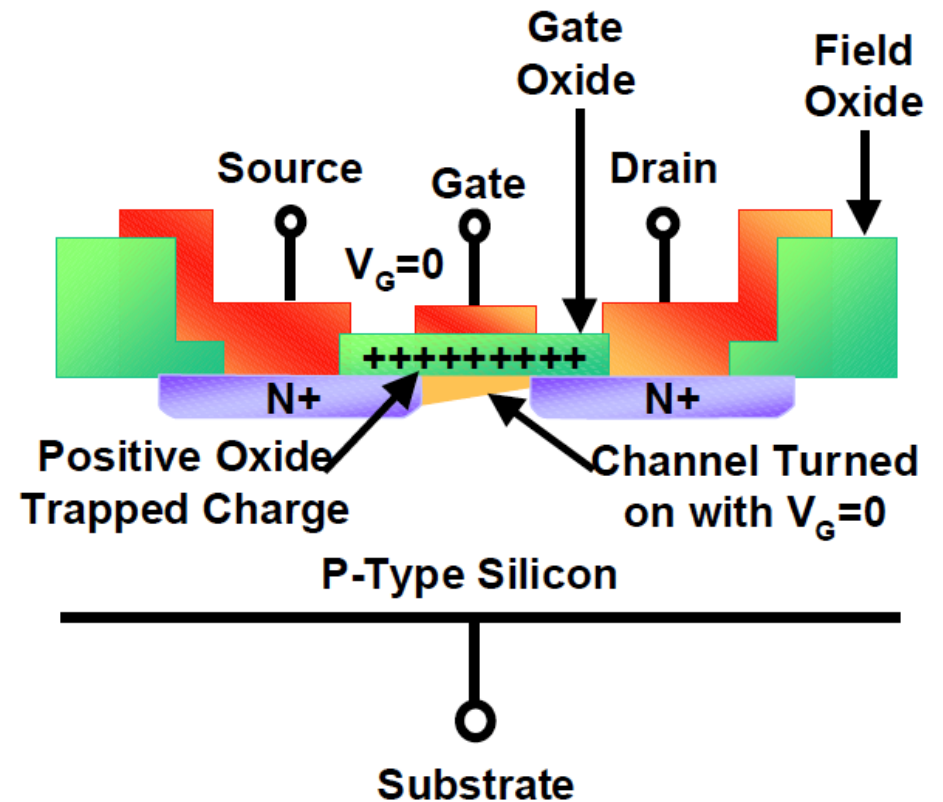

J.R. Schwank, 2002 NSREC Short Course

# Total Non-Ionizing Dose

- **Cumulative damage resulting from displaced atoms in semiconductor lattice**
- **Causes effects such as:**
  - Carrier lifetime shortening
  - Mobility degradation
- **Two metrics used:**
  - **TNID (Displacement Damage Dose) = energy going into displaced atoms per unit mass of material in sensitive volume**
    - $TNID = C \times NIEL \times \text{Fluence}$
    - NIEL is displacement energy lost by particle per unit path length
  - **Equivalent proton fluences (typically 10 or 50 MeV for space applications)**

Illustration of Damage Produced by 50-keV Si Recoil

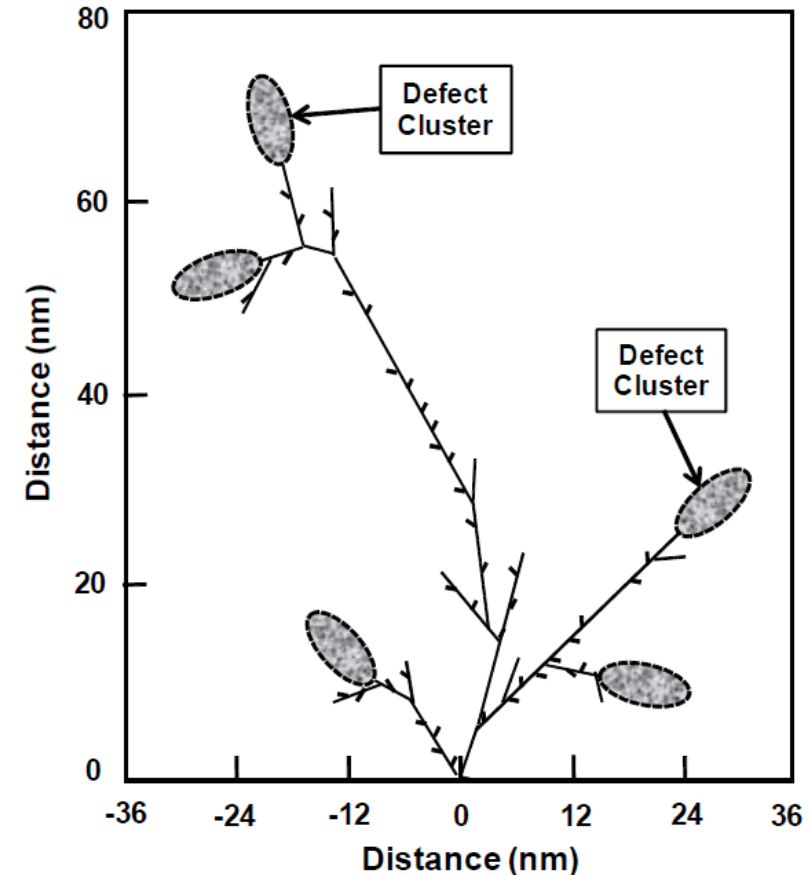

J.R. Srour, 2013 NSREC Short Course, after V.A.J. van Lint

# Charging Effects

- **Surface charging caused mainly by low energy plasma and incident photons ejecting photoelectrons**
- **Internal charging caused mainly by high energy electrons**
- **Discharges can occur if:**
  - **local electric field strength exceeds dielectric strength of material**
  - **potential difference between dielectric and conductive surfaces reaches a critical value**
- **See NSREC 2015 Short Course lecture by J. Mazur.**

**In-flight Solar Array Damage**

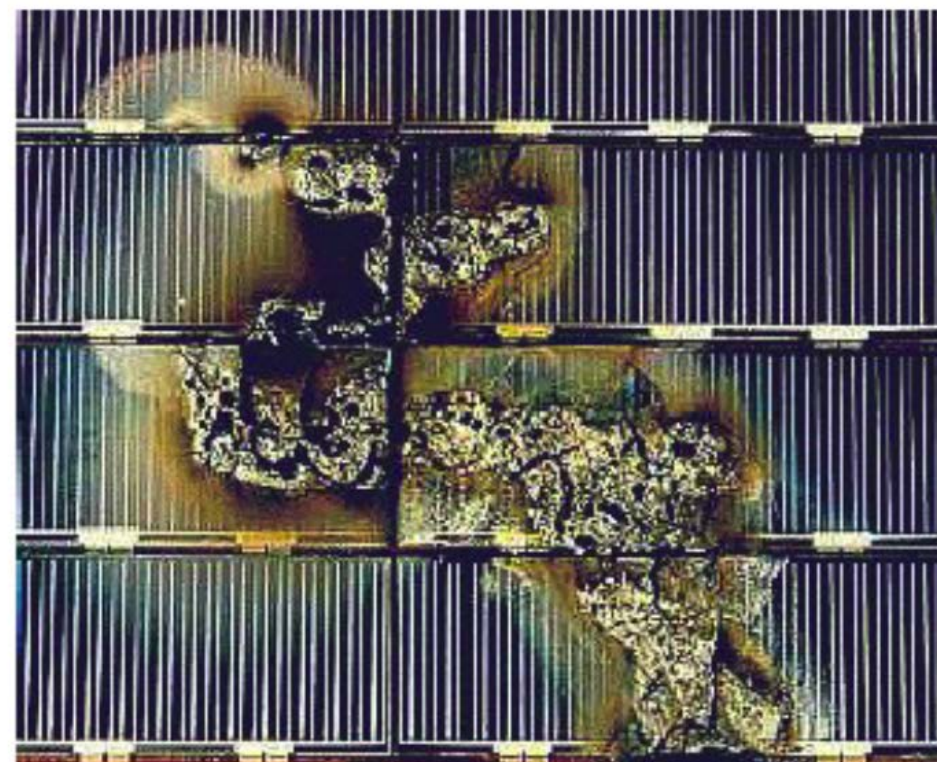

**NASA-HDBK-4002A, March 2011**

# Outline

- **Early universe from a radiation effects perspective**
  - Origin and abundances of electrons, protons, neutrons and heavy ions
- **Transition to modern times**
  - Sunspots and solar activity cycle
- **Modern times**
  - Space radiation environment
    - Galactic cosmic rays
    - Solar particle events
    - Van Allen Belts
- **Example Environments**
- **Summary**

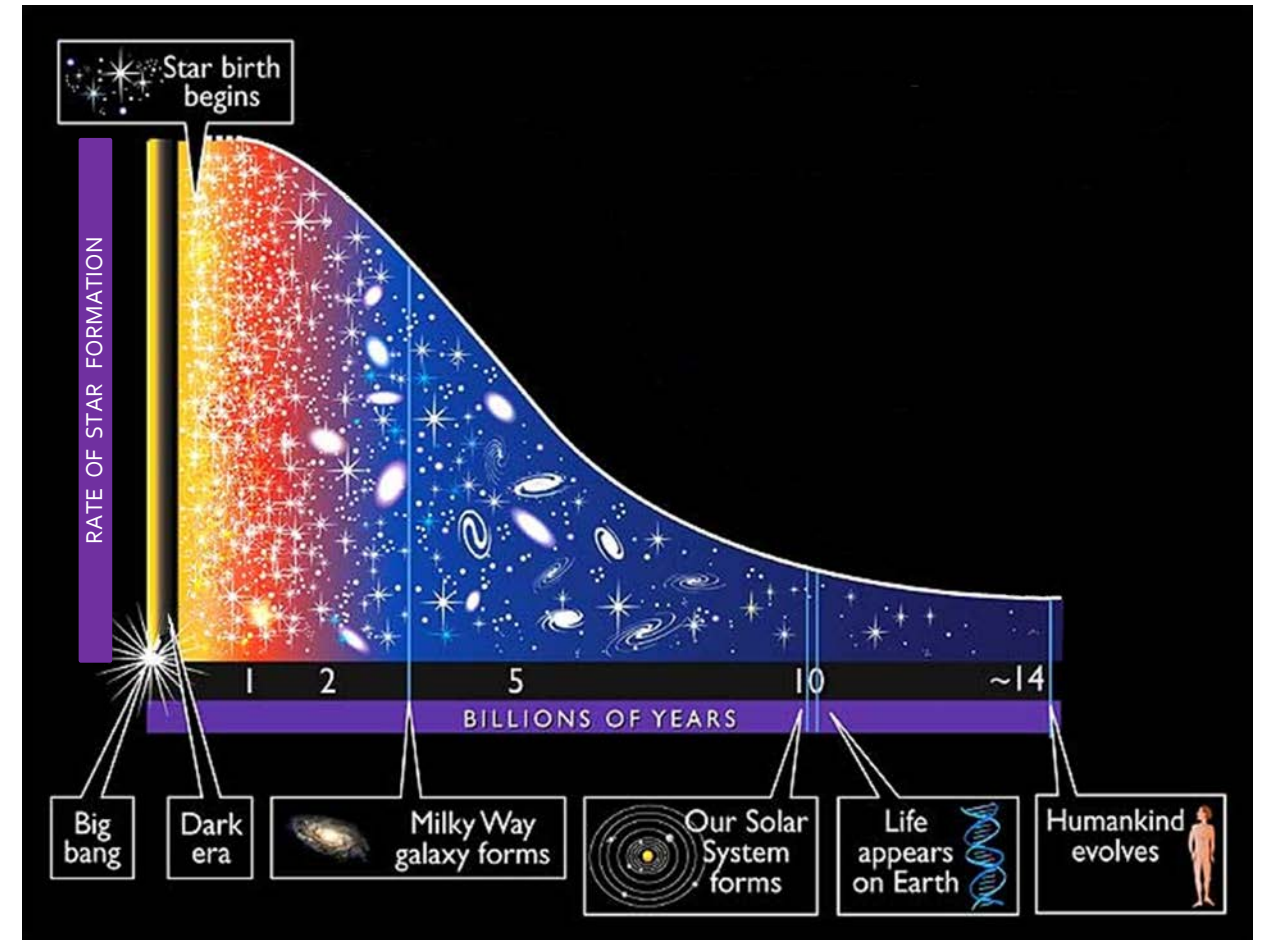

After M. Livio, NSREC, Seattle, WA, July 2005

# The Early Universe

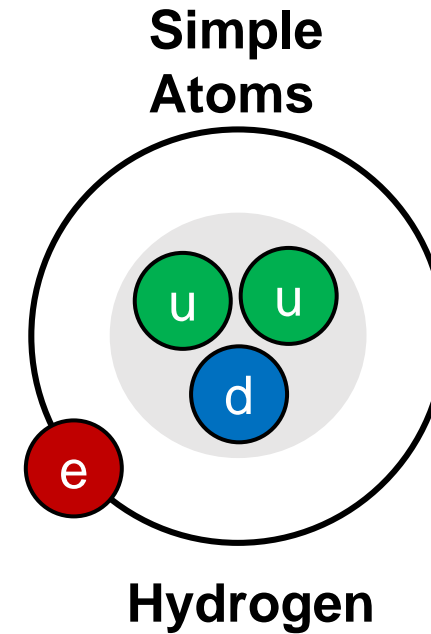
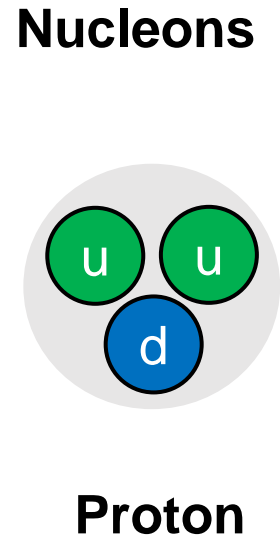
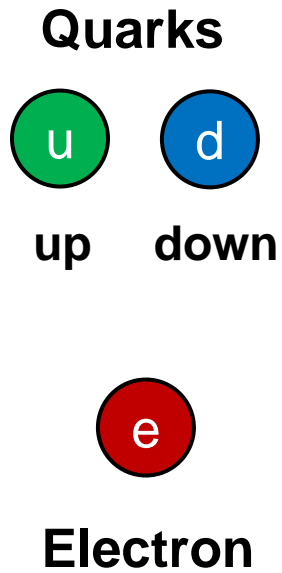



# Star Formation

Simple  
Atoms

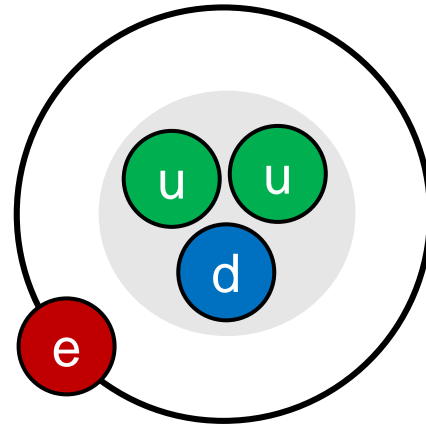

Hydrogen

“Pillars of Creation”



<http://hubblesite.org>



380,000 years

~100s million years

# Stellar Nucleosynthesis

- During the life of large stars a chain of nuclear fusion reactions starting with H and He produces elements from C to Fe in the star's core.
- Fe is the most stable element.
- When the core is entirely Fe, fusion is no longer possible and the star's life is over.

## Nuclear Fusion “Shells”

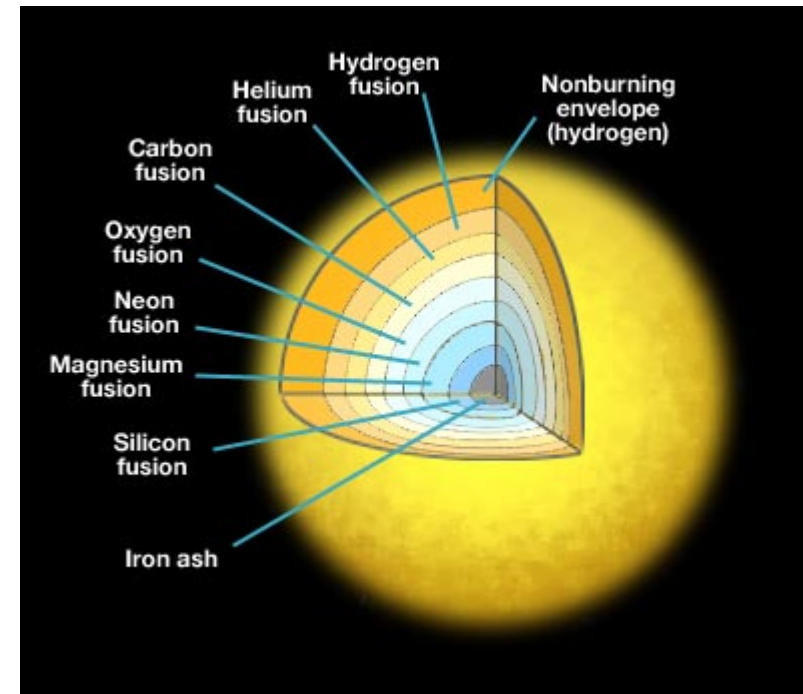

Penn State Astronomy & Astrophysics



# Extreme Event Nucleosynthesis

- **Two conditions are required to produce elements heavier than Fe:**
  - High neutron density
  - Extreme energy release
- **Two most likely processes occur after the active lifetime of certain stars**
  - Supernovae
  - Neutron star collisions
    - First observed August 17, 2017
- **Produce elements up to U**

## Neutron Star Merger (Illustration)



Credit: NASA/GSFC/CI Lab





# Summary: Origin and Abundances of Elements

- **e, p, n and  $\alpha$ 's were present shortly after the Big Bang**
- **Elements C through Fe are synthesized in stars larger than the sun**
  - **Sun's heavy elements originated from previous generation stars**
- **Elements heavier than Fe originate in rare, explosive processes**
  - **Results in very low fluxes**
  - **Important to consider for high confidence level applications, e.g., destructive or critical SEE**

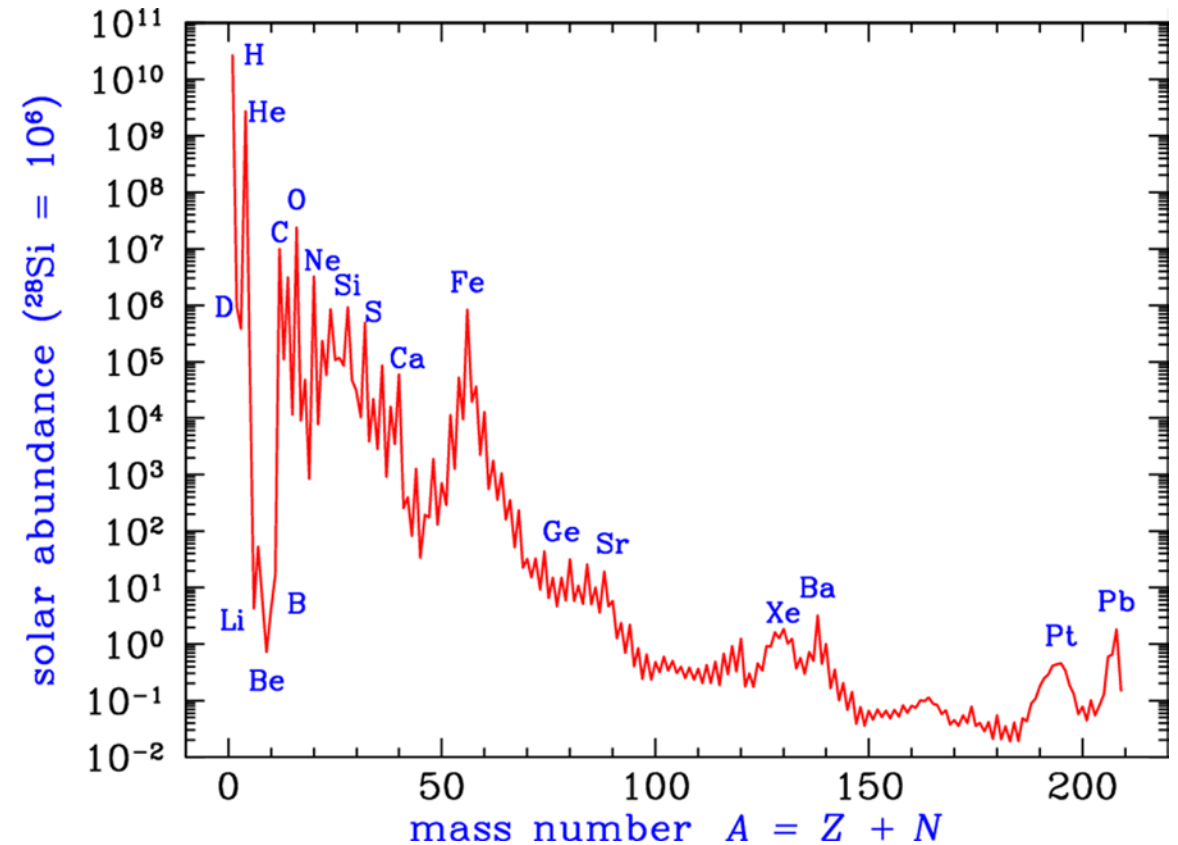

Anders and Grevesse, *Geochimica et Cosmochimica Acta*, Jan. 1989

# Transition to Modern Times

- **Galileo's pioneering studies with the telescope starting in 1609 may be viewed as the start of modern experimental astronomy**
- **One of the first to observe sunspots through a telescope**
- **Today sunspots are viewed as a proxy to solar activity**
  - **Active regions have twisted magnetic fields that inhibit local convection**
  - **Region is cooler and appears darker when viewed in visible light.**

**Images Taken Feb. 3, 2002:**

**Visible Light**

**Ultraviolet Light**

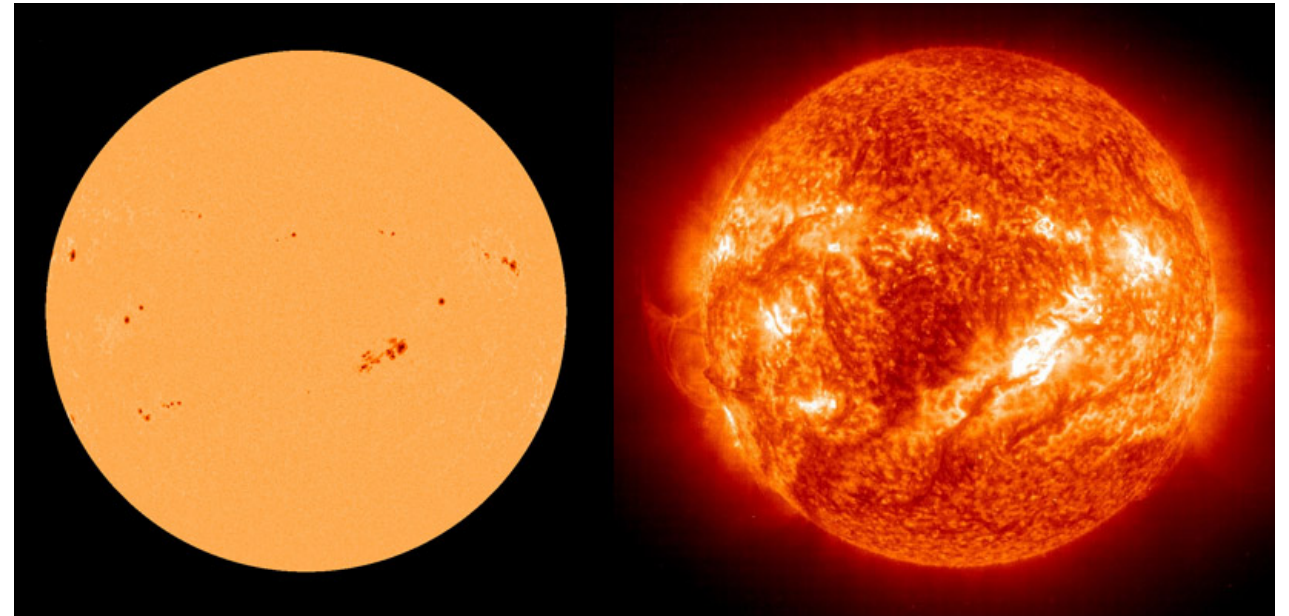

**Credit: ESA and NASA (SOHO)**

# Transition to Modern Times

- **Era of modern space climatology began to take form in 1843 when Schwabe published paper describing the discovery of the sunspot cycle**
  - 17 year long study!
- **Cycle indicates the sun's magnetic activity levels**
  - Solar maximum - high
  - Solar minimum - low

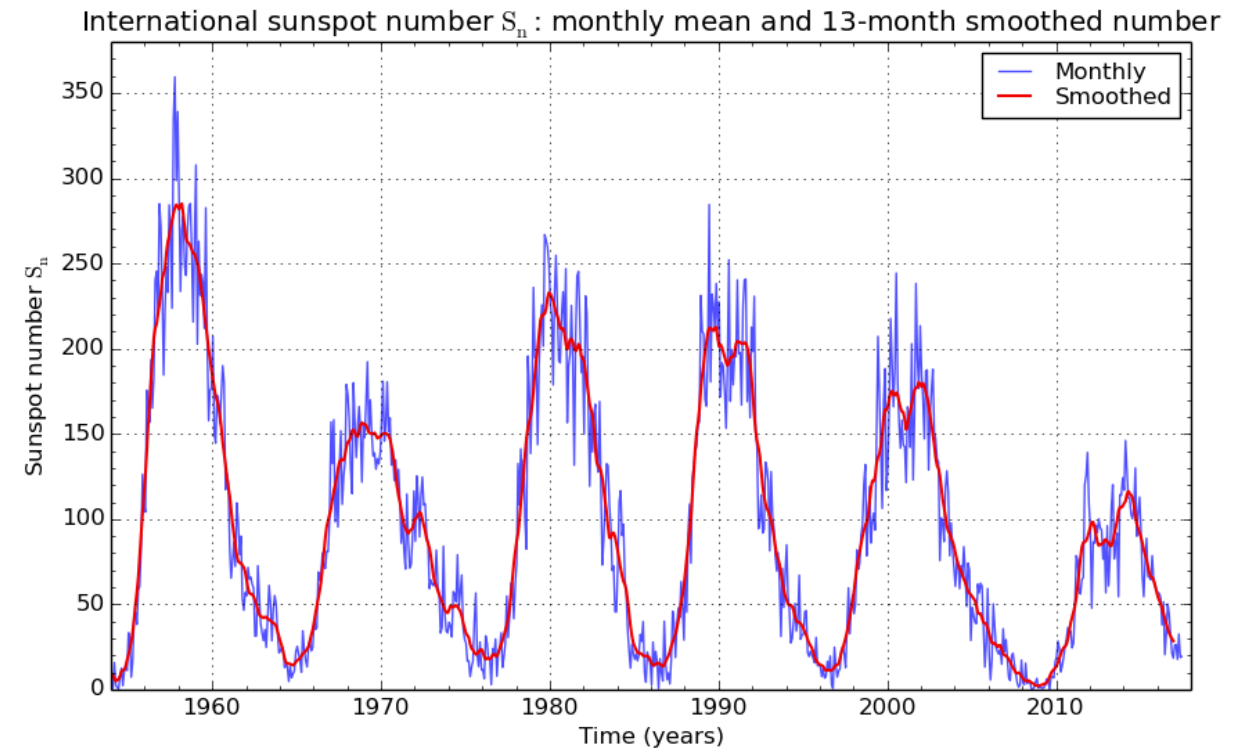

Credit: WDC-SILSO, Royal Observatory of Belgium

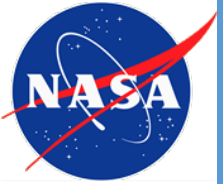

Windows Media Player

10804\_Solar\_Cycle\_MPEG4\_1280x720\_29.97

NASA HELIOPHYSICS

00:06

A screenshot of a Windows Media Player window. The title bar reads "Windows Media Player". Below it, the file name "10804\_Solar\_Cycle\_MPEG4\_1280x720\_29.97" is displayed. The main video area shows the NASA HelioPhysics title screen, which features the text "NASA HELIOPHYSICS" in white, with a glowing yellow and white arc behind the letter "A". At the bottom, there is a playback control bar with a progress indicator at 00:06, a play button, and other standard media controls.

# Effects of Sun's Magnetic Activity on Space Climatology

- Sun's influence in pervasive
- Source of protons and electrons in Van Allen Belts
- As activity increases approaching solar maximum
  - Frequency of solar particle events increases
  - Galactic cosmic ray fluxes entering solar system decreases
    - In turn this decreases the atmospheric neutron population

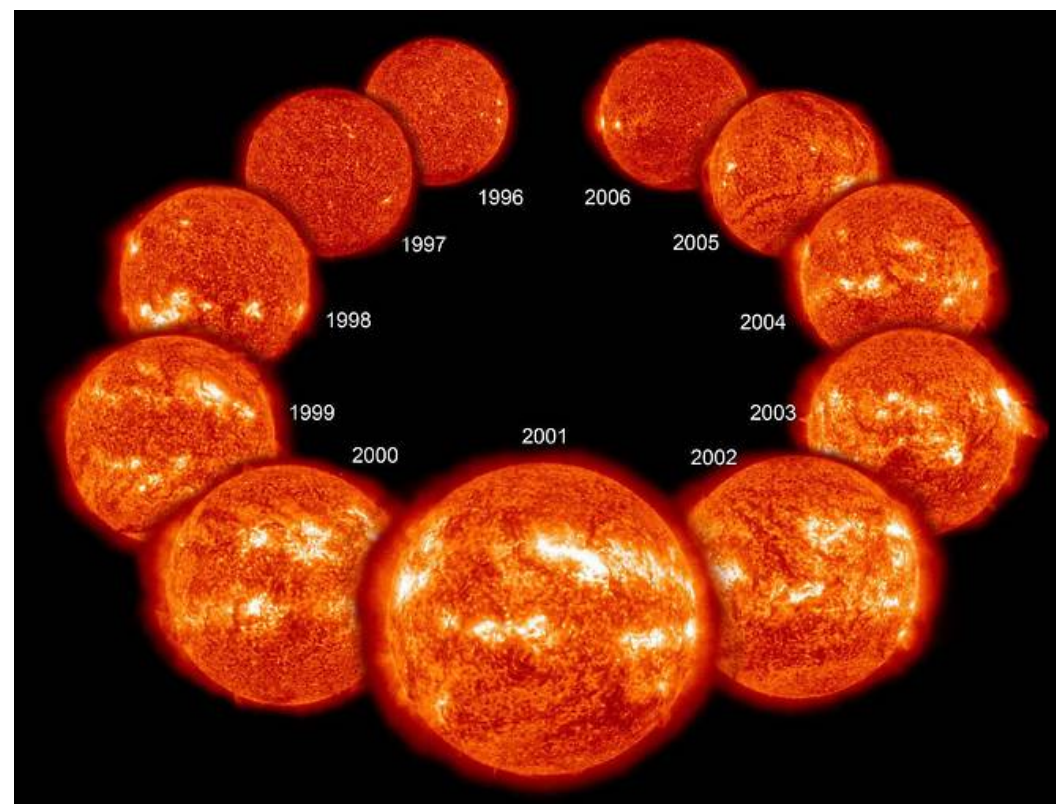

Credit: NASA

# Modern Times – Space Climatology

- **Space weather – short term, e.g., daily, conditions of the space radiation environment for a given location or orbit.**
- **Space climate – space weather conditions over an extended time or mission duration**
  - **Mean or median value**
  - **High confidence level or worst case value**
  - **Complete distribution of values**

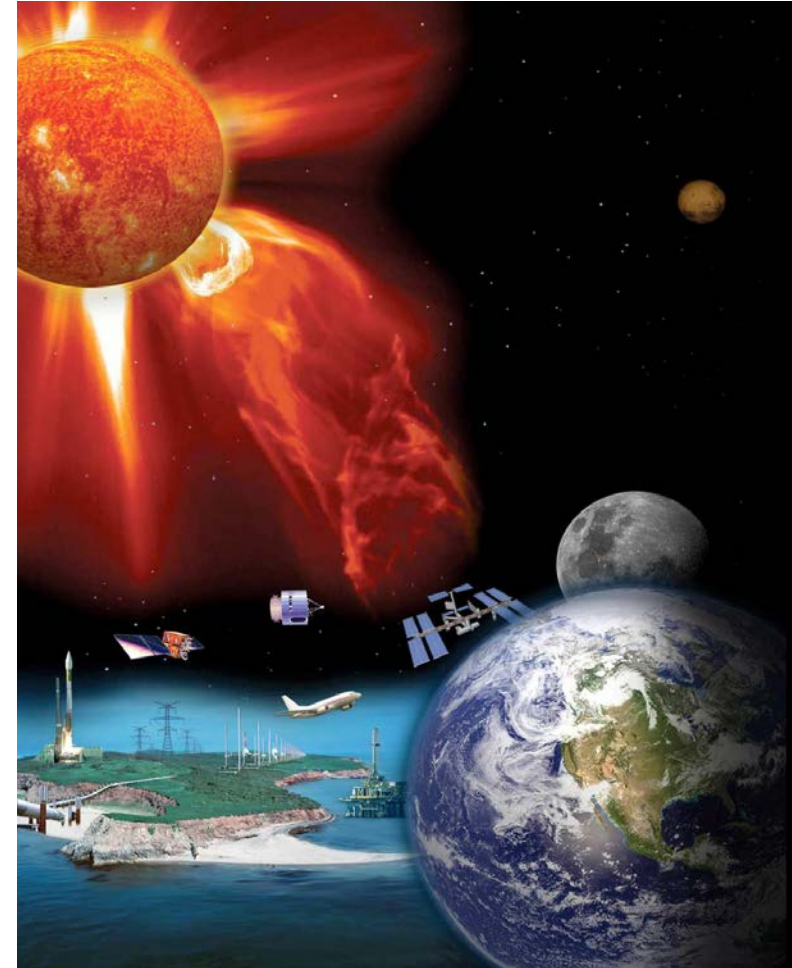

**Credit: NASA**



# Space Environment Model Use in Spacecraft Life Cycle

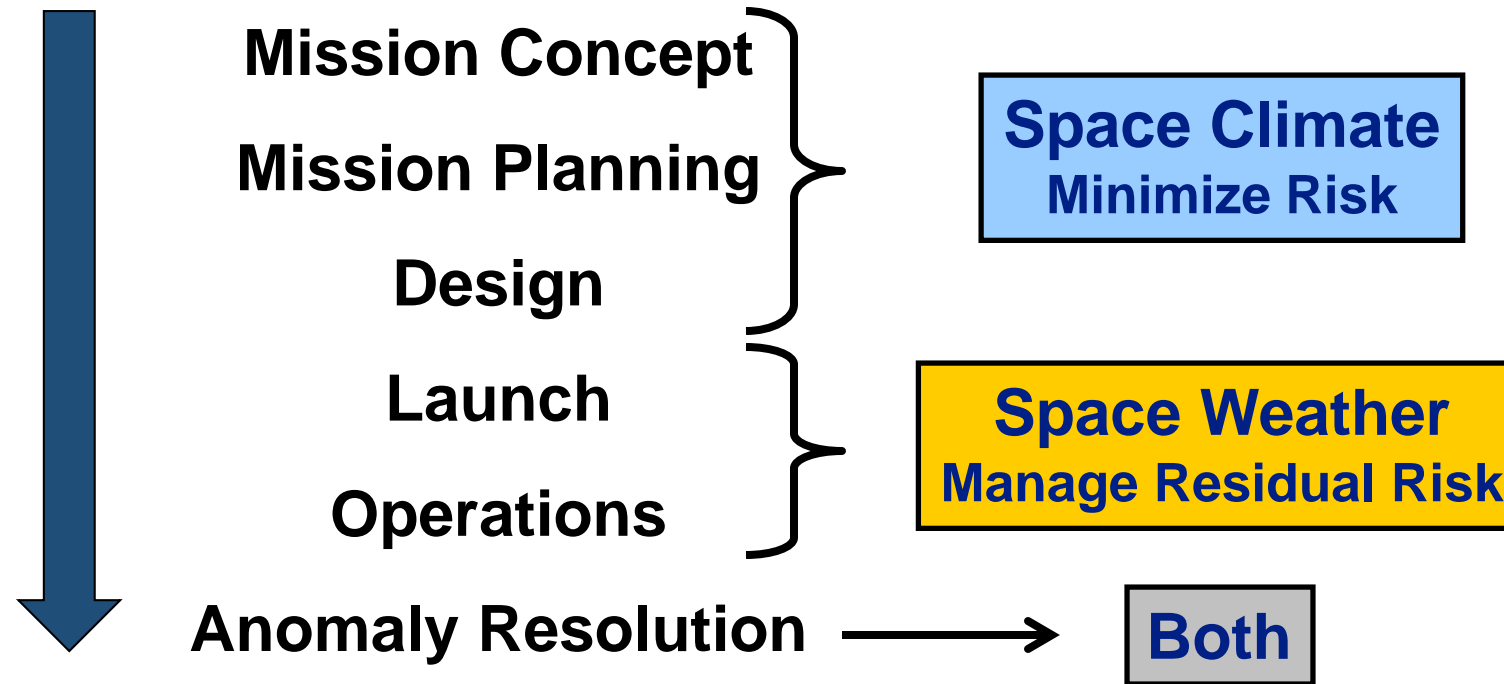

After J.L. Barth

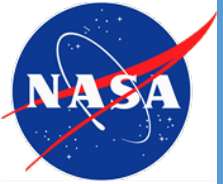

# Modern Times



Credit: <http://hubblesite.org>

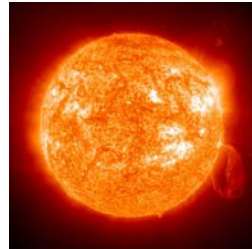

Credit: NASA (SDO)

GCR  
Discovered  
1912



SEP  
Discovered  
1942

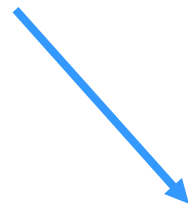

Transistor  
Invented  
1947



Van Allen Belts  
Discovered  
1958



First NSREC  
1964

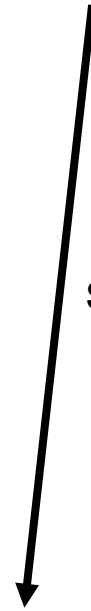

SEU in  
Spacecraft  
1975



First NSREC  
Short Course  
1980



First RADECS  
1989



First NSREC  
Space Environment  
Session  
1991



NSREC  
2018



1900

1940

1980

2020



# Outline: Galactic Cosmic Rays

- **Properties**
- **Models**
  - Badhwar and O'Neill 2014
  - Moscow State University (MSU)
- **Current Issue**
  - Elevated Fluxes during Prolonged Solar Minima

## Kepler's 1604 Supernova Remnant

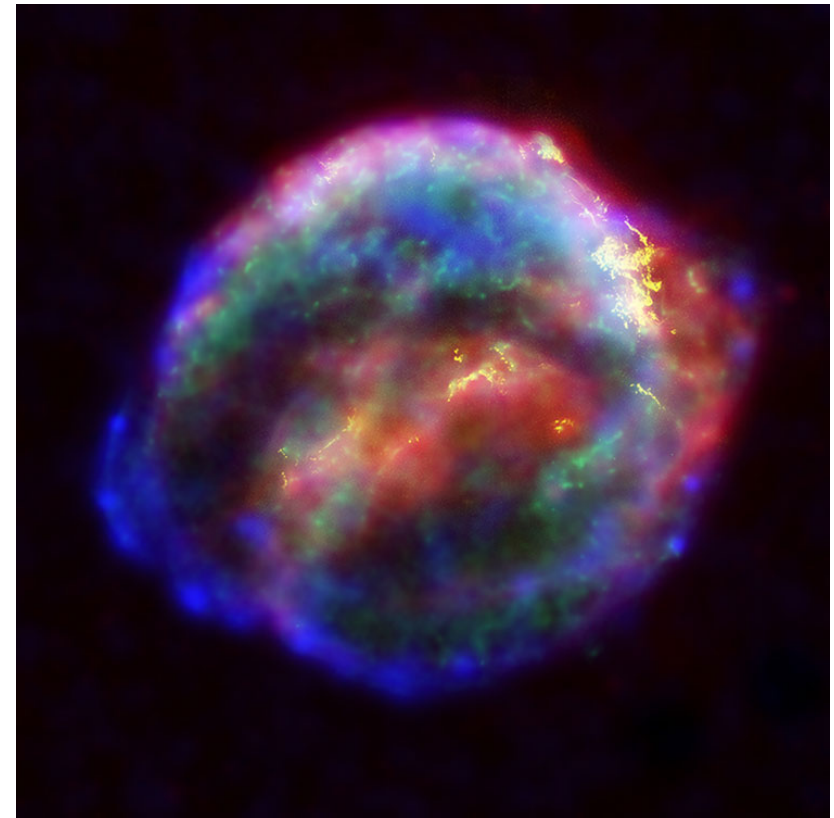

Credit: NASA, ESA & JHU APL (Chandra, Hubble and Spitzer)

# Composition

- **Galactic Cosmic Rays (GCR) are high energy charged particles that originate outside our solar system.**
- **Composed of all naturally occurring elements**
  - 90% hydrogen
  - 9% helium
  - 1% heavier ions
- **Generally similar to solar abundances but secondary products due to GCR fragmentation smooths out abundances**

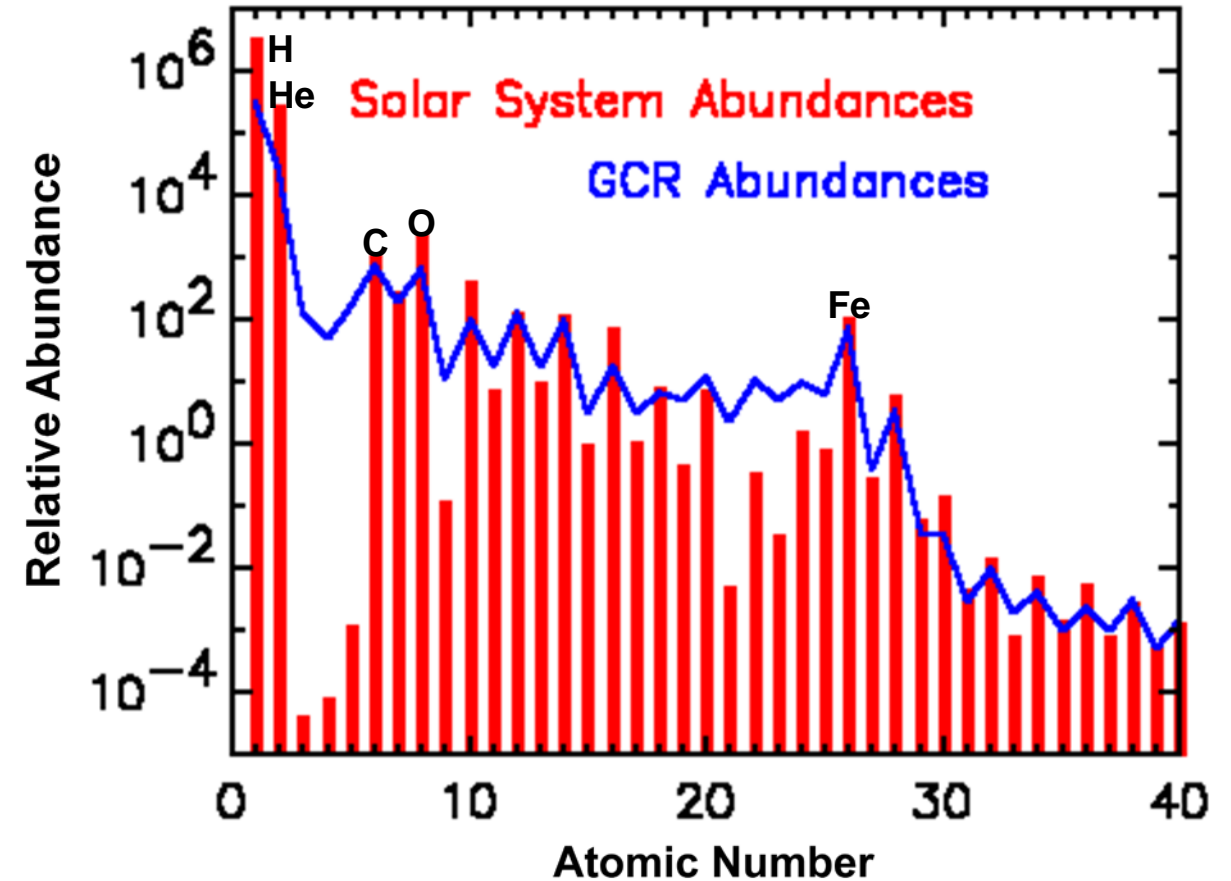

<https://imagine.gsfc.nasa.gov/>

# Energy Spectra

- **For GCR energies  $< 10^{15}$  eV:**
  - Mainly attributed to supernovae within Milky Way galaxy and neutron star collisions
  - Integral fluxes  $\sim 1 \text{ cm}^{-2}\text{s}^{-1}$ , dependent on solar cycle
  - Significant for SEE
  
- **For GCR energies  $> 10^{15}$  eV:**
  - Unknown origin, especially highest energies
    - Extragalactic?
    - Greisen-Zatsepin-Kuzman (GZK) limit
  - Not significant for SEE

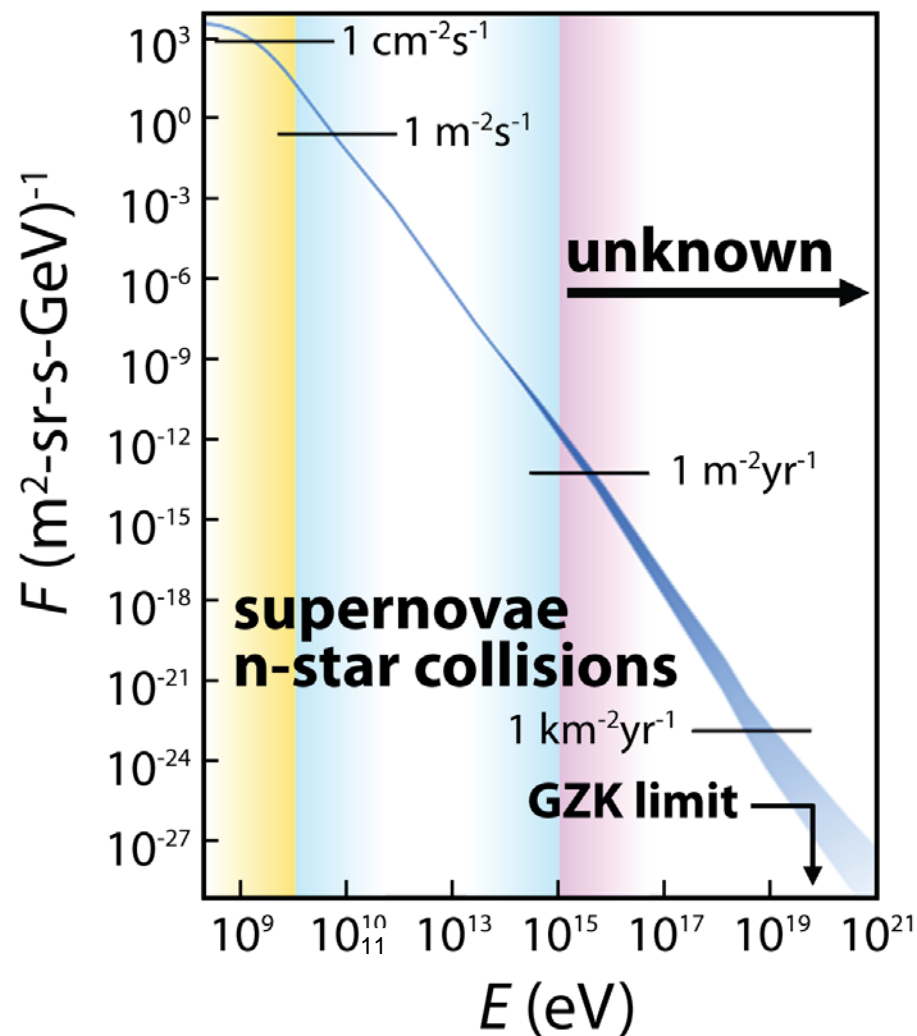

S. Swordy, Space Sci. Rev., Oct. 2001

# Variation with Solar Cycle

- Fluxes modulated by magnetic field in sun and solar wind
  - High activity during solar maximum attenuates fluxes for energies less than about 20 GeV per nucleon
  - Worst case situation during solar minimum

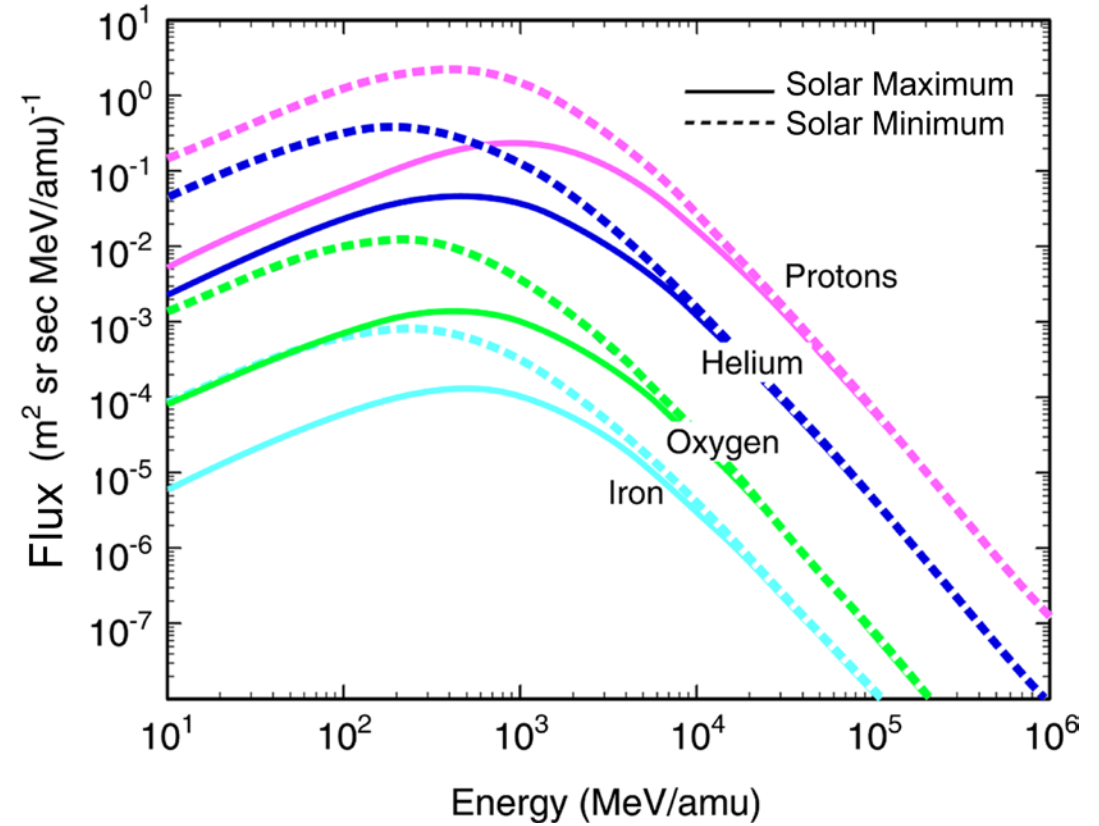

G.D. Badhwar and P.M. O'Neill, Adv. Space Res., 1996

# Variation with Solar Cycle

## Energy Spectra

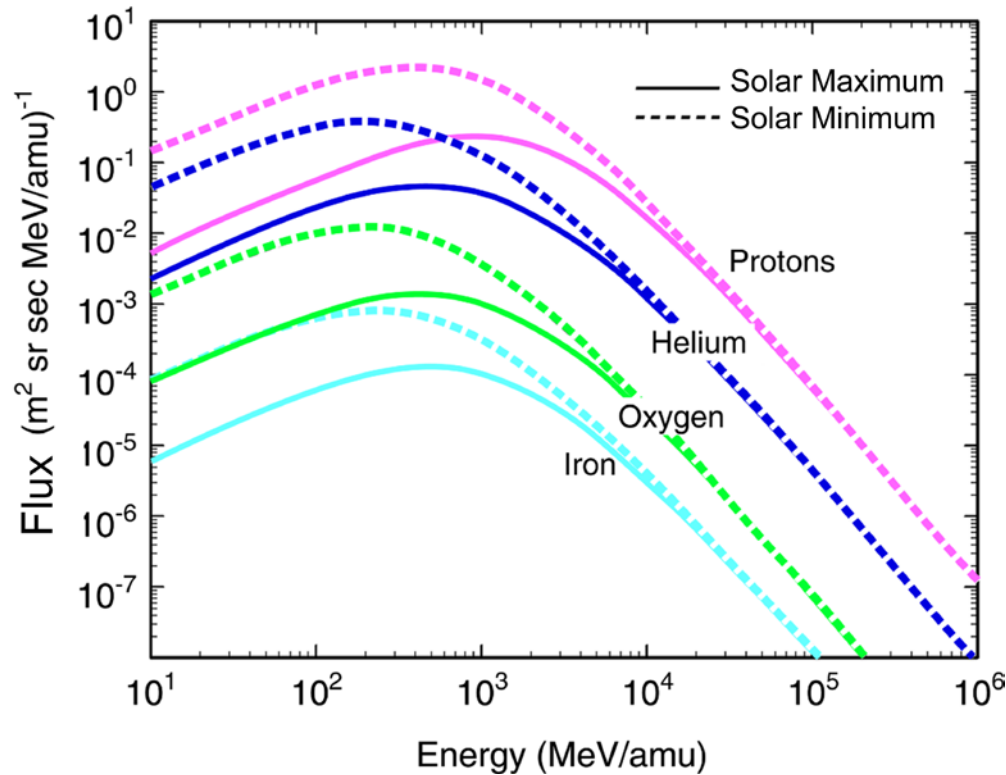

## LET Spectra

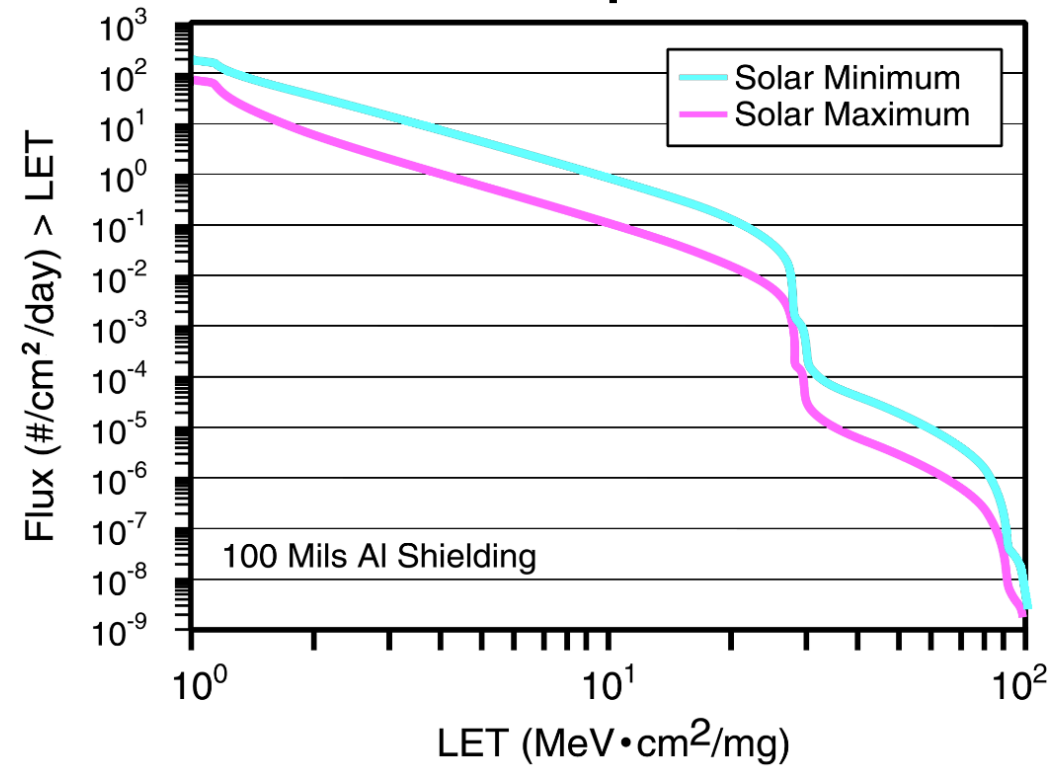

G.D. Badhwar and P.M. O'Neill, Adv. Space Res., 1996

# Models

- **Models based on theory of solar modulation of GCR fluxes**
- **Describe penetration of GCR Local Interstellar Spectra (LIS) into heliosphere and transport to near Earth**
- **Solar modulation results in flux variation over the solar cycle.**

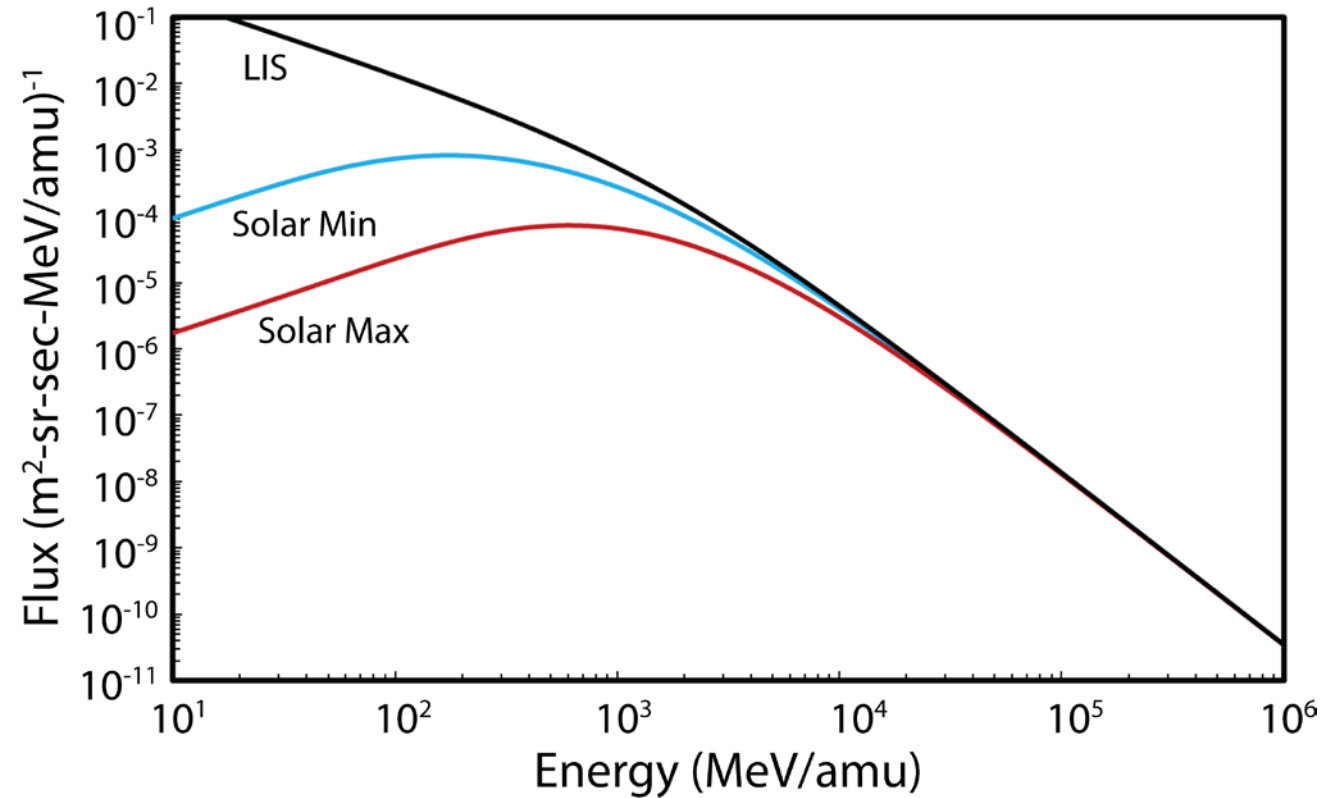

P.M. O'Neill, S. Golge and T.C. Slaba, NASA Tech. Paper, March 2015

# Models

- Two popular models are used for SEE that parameterize solar modulation with sunspot numbers
- **Badhwar – O’Neill 2014 Model**
  - Broader data base and slightly more accurate
- **MSU (Nymmik) model used in CREME96**
  - Integrated with suite of programs for SEE rate calculation

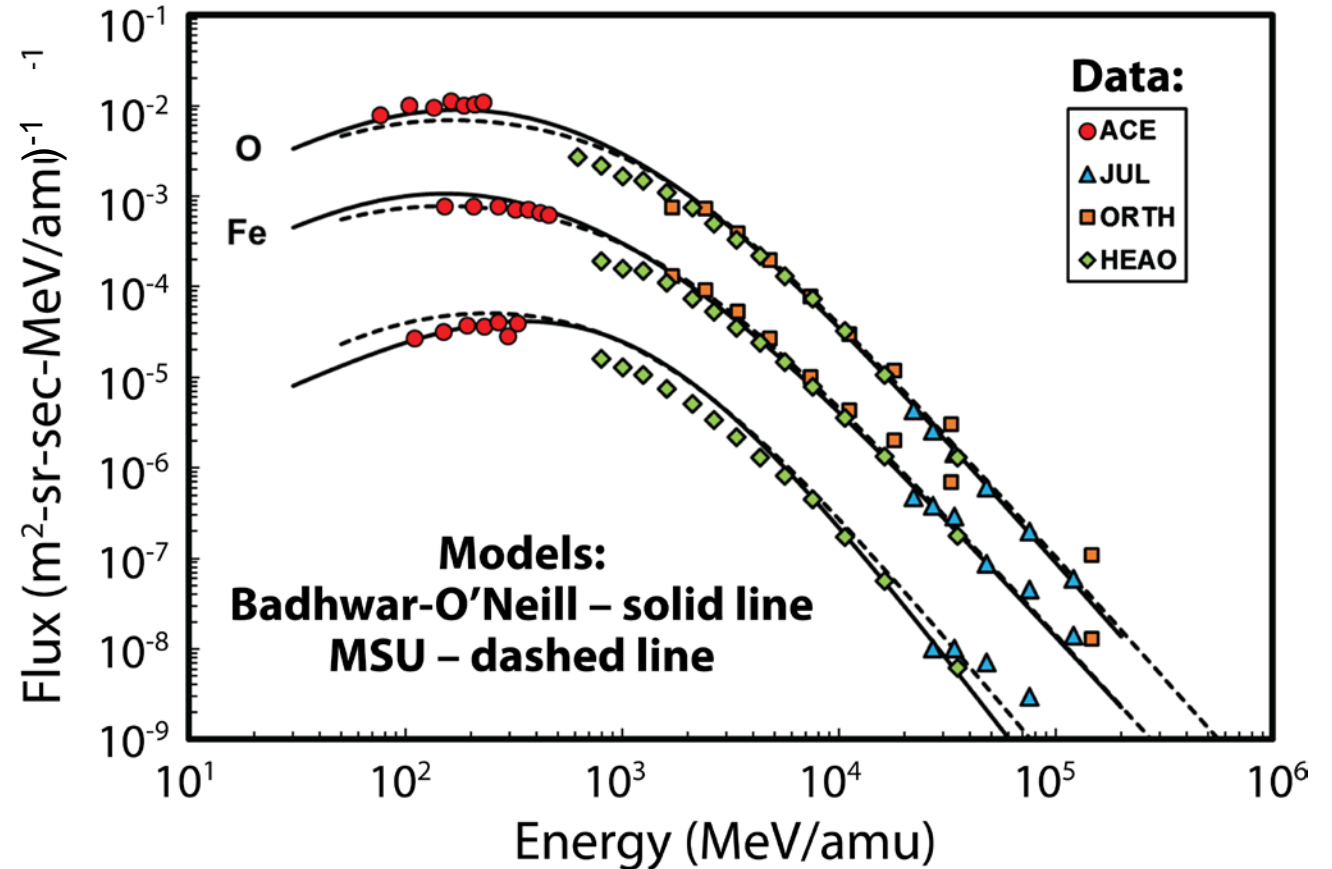

P.M. O’Neill, S. Golge and T.C. Slaba, NASA Tech. Paper, March 2015



# Are Models Adequate for “Deep” and Prolonged Solar Minima?

- **Most recent solar minimum has raised concerns about elevated GCR fluxes during subsequent solar minimum periods.**
  - ~2009 was deepest in space era
  - 1977 more typical and used as default in CREME96
- **Fluxes during minima do not vary by more than ~30% dating back to 1750**
- **Models, particularly Badhwar-O’Neill 2014 are adequate for electronics design.**



P.M. O’Neill, S. Golge and T.C. Slaba, NASA Tech. Paper, March 2015



# Outline: Solar Energetic Particles

- **Properties**
  - **Coronal Mass Ejections (CME)**
  - **Solar Flares**
- **Models – Protons & Heavy Ions**
  - **Cumulative Fluences**
  - **Worst Case Events**
    - **Current Issue: Use of statistical models vs. worst case observations**

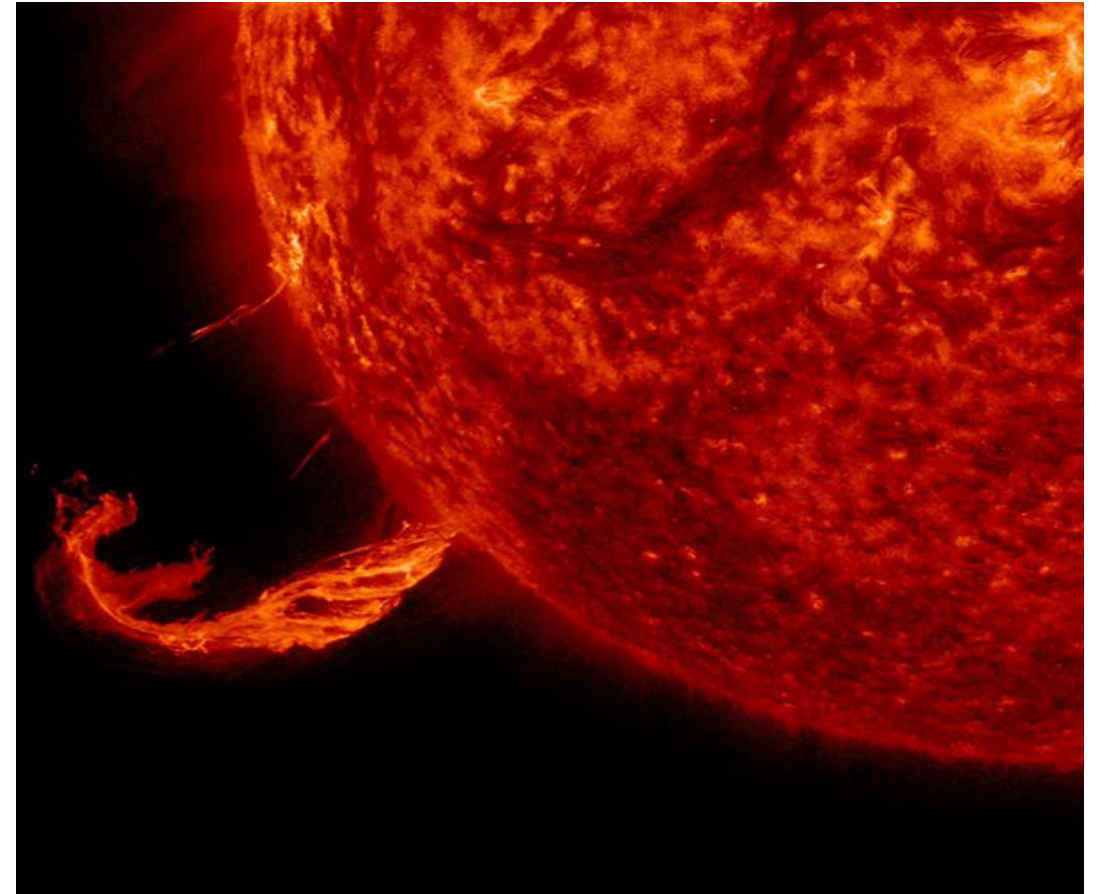

**Credit: NASA (SDO)**

# Solar Energetic Particle Production

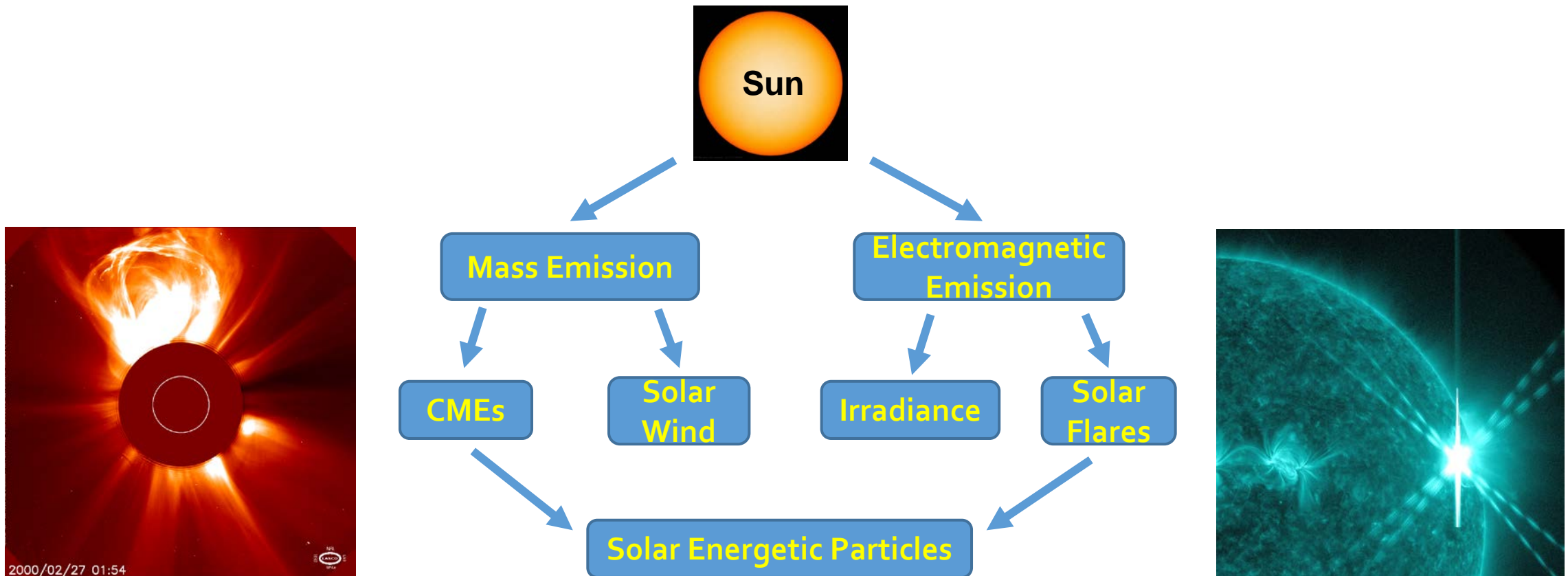
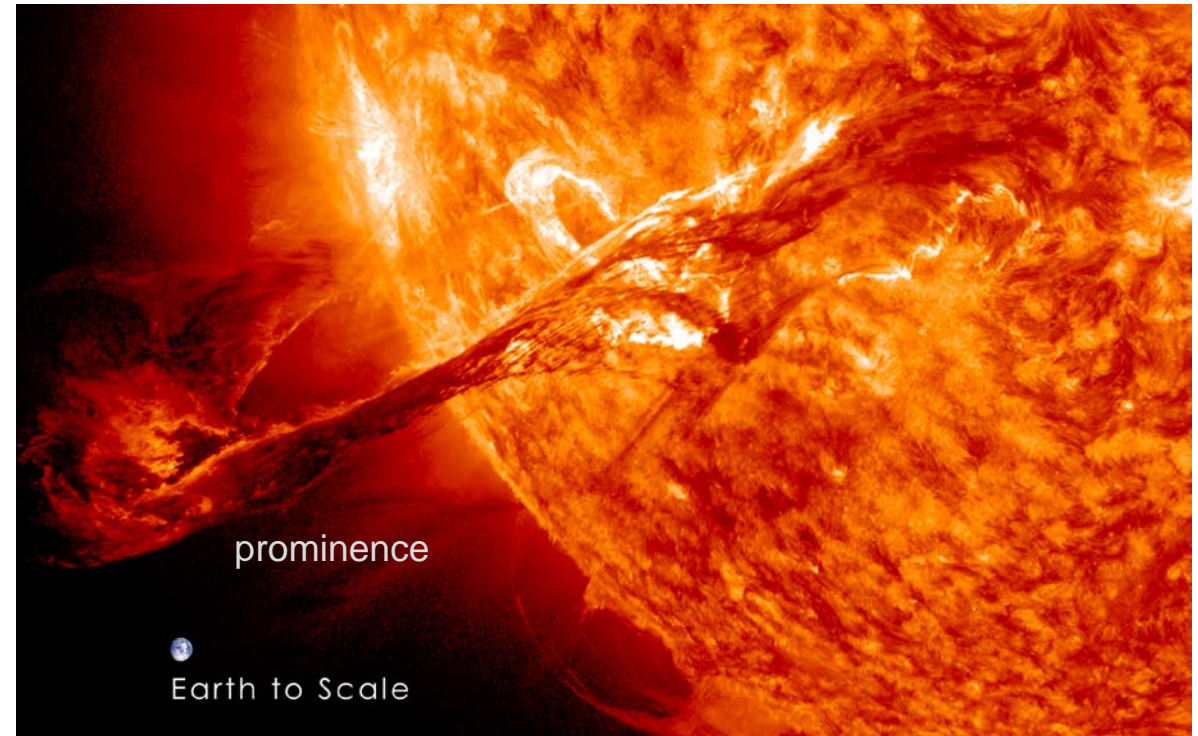

Image credits: NASA and ESA (SOHO and SDO)

# Coronal Mass Ejection Properties

- Responsible for major disturbances in Earth's magnetosphere and interplanetary space
- Typically takes half day to a few days to reach Earth
- Very proton rich ~ 96% on average
- Energies up to ~ GeV/n
- Cause TID, TNID and SEE
- Extreme CME magnitudes
  - $> 10^{14}$  kg of magnetized plasma ejected
  - $> 10$  MeV/n fluence can exceed  $10^9$  cm<sup>-2</sup>
  - $> 10$  MeV/n peak flux can exceed  $10^5$  cm<sup>-2</sup>s<sup>-1</sup>
  - ~ few krad(Si) behind 100 mils Al



Credit: NASA (SDO)



Windows Media Player

11095\_Magnificent\_CME\_MPEG4\_1920x1080\_29.97

NASA HELIOPHYSICS

00:06

A screenshot of a Windows Media Player window. The title bar says "Windows Media Player". The address bar shows the file name "11095\_Magnificent\_CME\_MPEG4\_1920x1080\_29.97". The main video area is black with the NASA HelioPhysics logo in the center. The logo consists of the word "NASA" in white, followed by a glowing yellow crescent moon, and then the word "HELIOPHYSICS" in white. At the bottom, there is a playback control bar with a progress bar showing 00:06, and buttons for play/pause, stop, previous, next, and volume.



# Solar Cycle Dependence

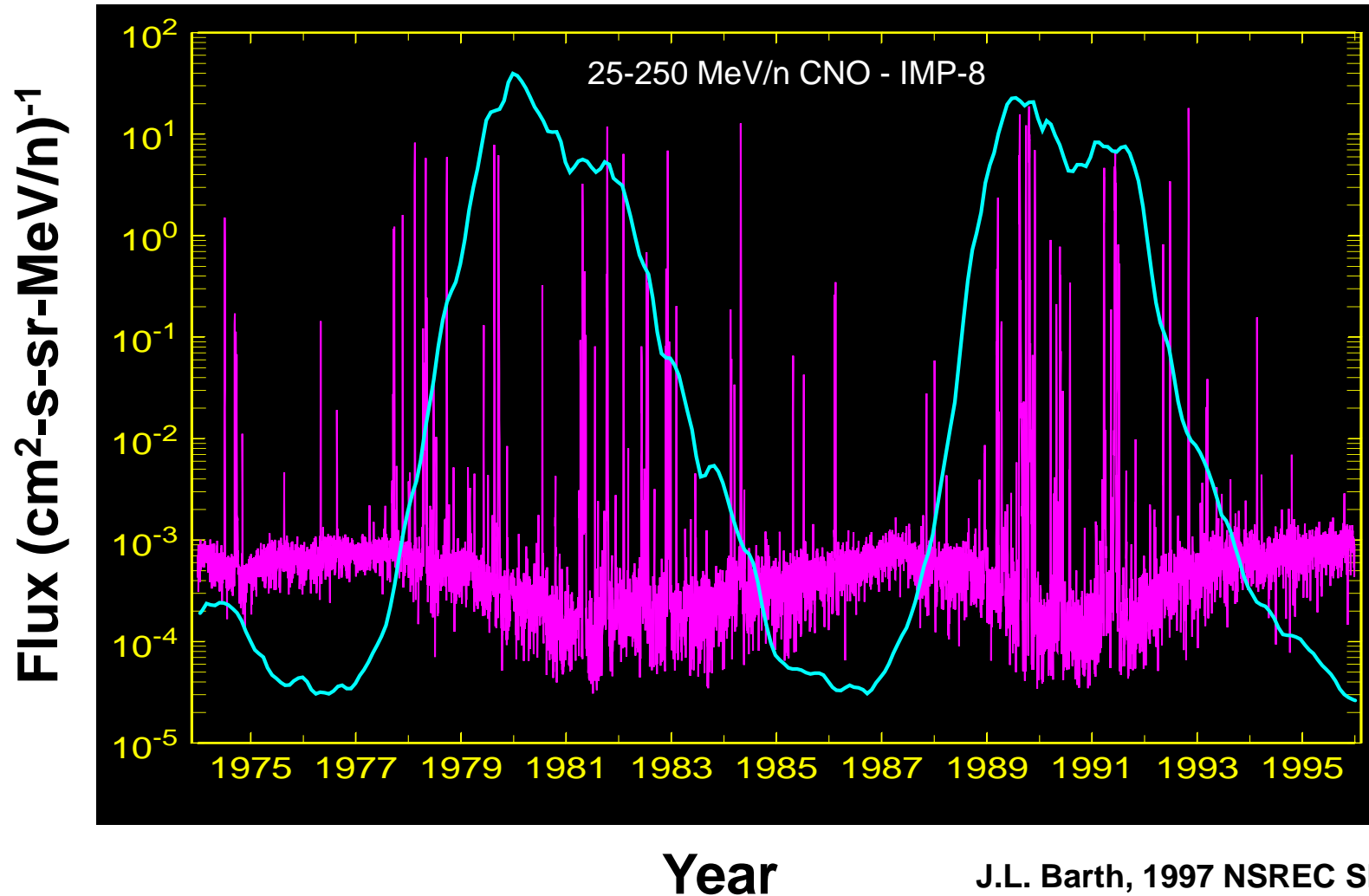

J.L. Barth, 1997 NSREC Short Course

# Solar Particle Models and Applications

## Coronal Loops

- **Cumulative fluences**
  - Application to TID, TNID, destructive SEE
- **Worst case events**
  - Application to non-destructive SEE
  - How high can the SEE rate get?

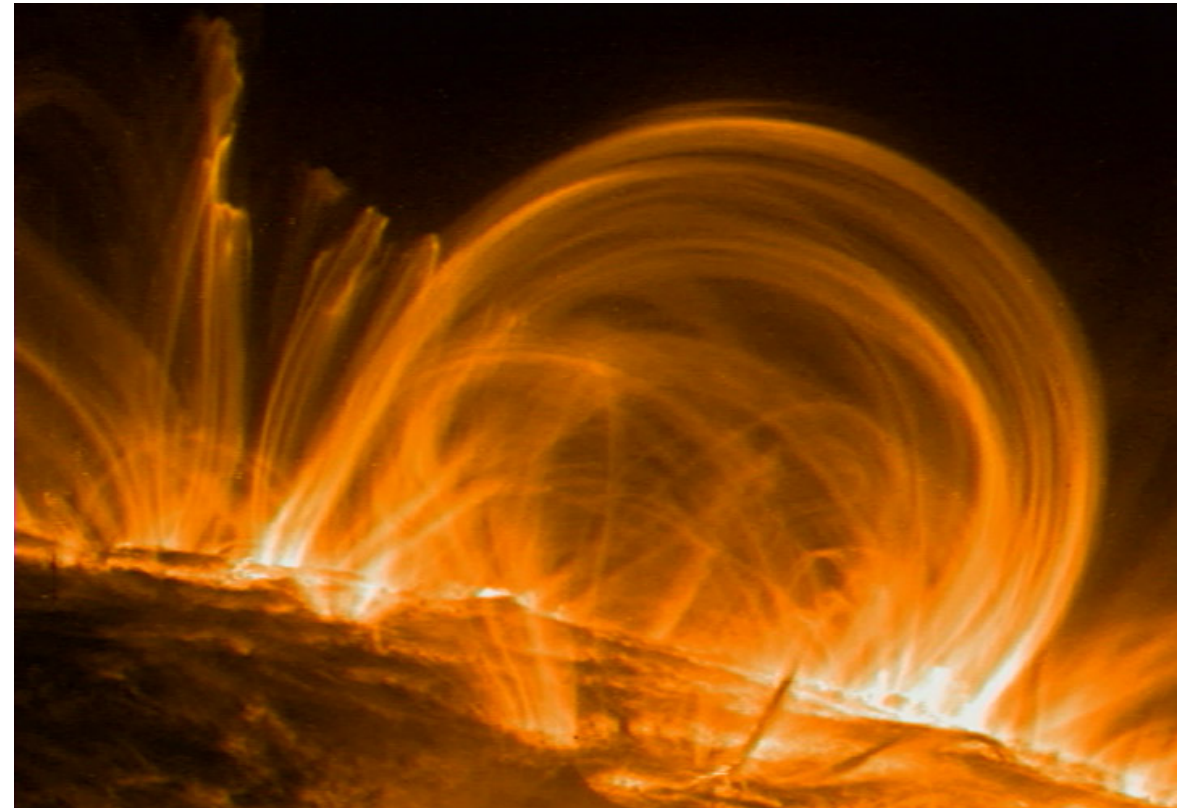

Credit: NASA (TRACE)

# Cumulative Proton Fluence Model ESP/PSYCHIC

- **Uses lognormal distributions to model cumulative fluences**
  - Validated by direct data analysis and simulation
- **Lognormal parameters for N years derived from fitted parameters of 1-year distributions**
- **Avoids making assumptions about event specifics, i.e., start and stop times, waiting times between events, etc.**

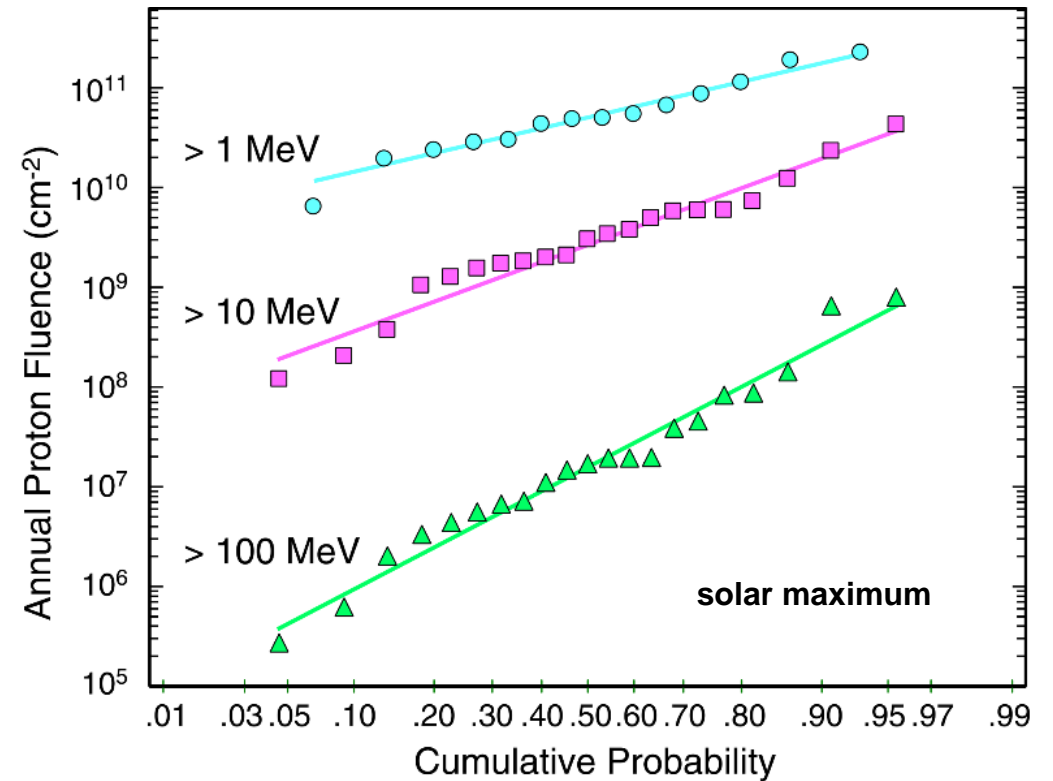

M.A. Xapsos et al., IEEE TNS, June 2000



# Cumulative Proton Fluence Model ESP/PSYCHIC

- **Output is the energy spectrum at a given level of confidence for the specified mission duration**
- **Confidence level represents the probability the calculated fluence level will not be exceeded during the mission**

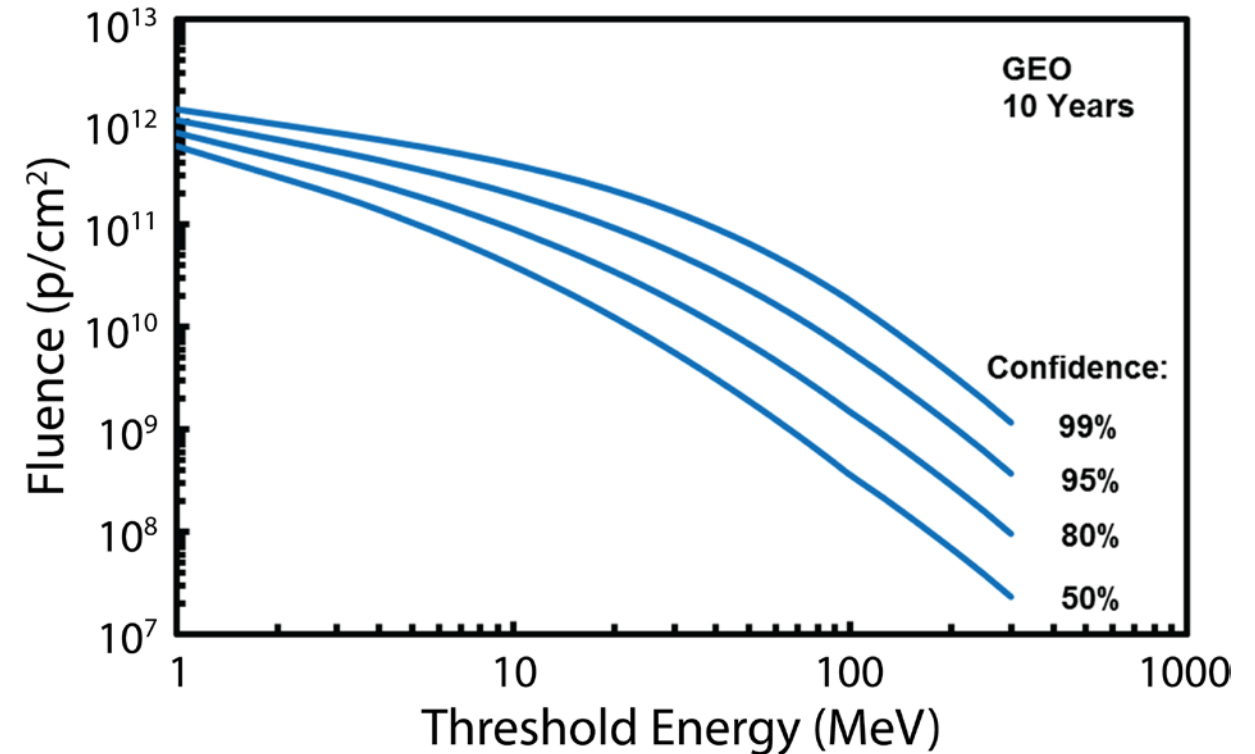



# Cumulative Solar Heavy Ions ESP/PSYCHIC

- Long-term (average) LET spectrum based on:
  - Satellite measurements from ACE, IMP-8, GOES, ISEE-3
  - Abundance model based on photospheric processes and chemical composition
- LET spectrum can be broken into 4 components
  - Each component drops sharply to zero fluence at the Bragg Peak (maximum LET) of the highest atomic number element
  - Note correspondence to nucleosynthesis processes
    - Big Bang (LET < ~1)
    - Stellar (LET < ~30)
    - Extreme Events (LET in full range)

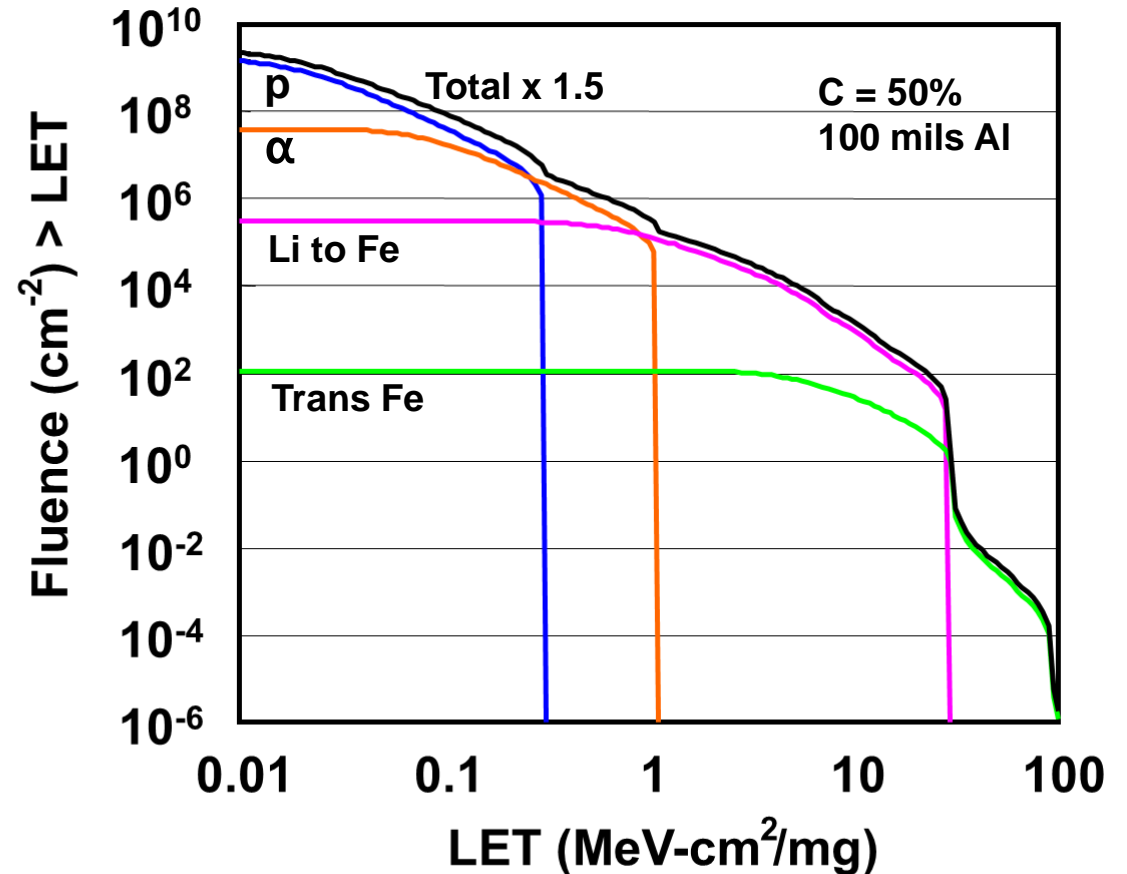

M.A. Xapsos et al., IEEE TNS, Dec. 2007

# Worst Case Solar Particle Events

- One approach is to design to a well-known large event
- Events most often considered:
  - October 1989
  - August 1972
  - ~~Carrington Event 1859~~
    - Published ice core data not a reliable indicator of solar proton event magnitudes

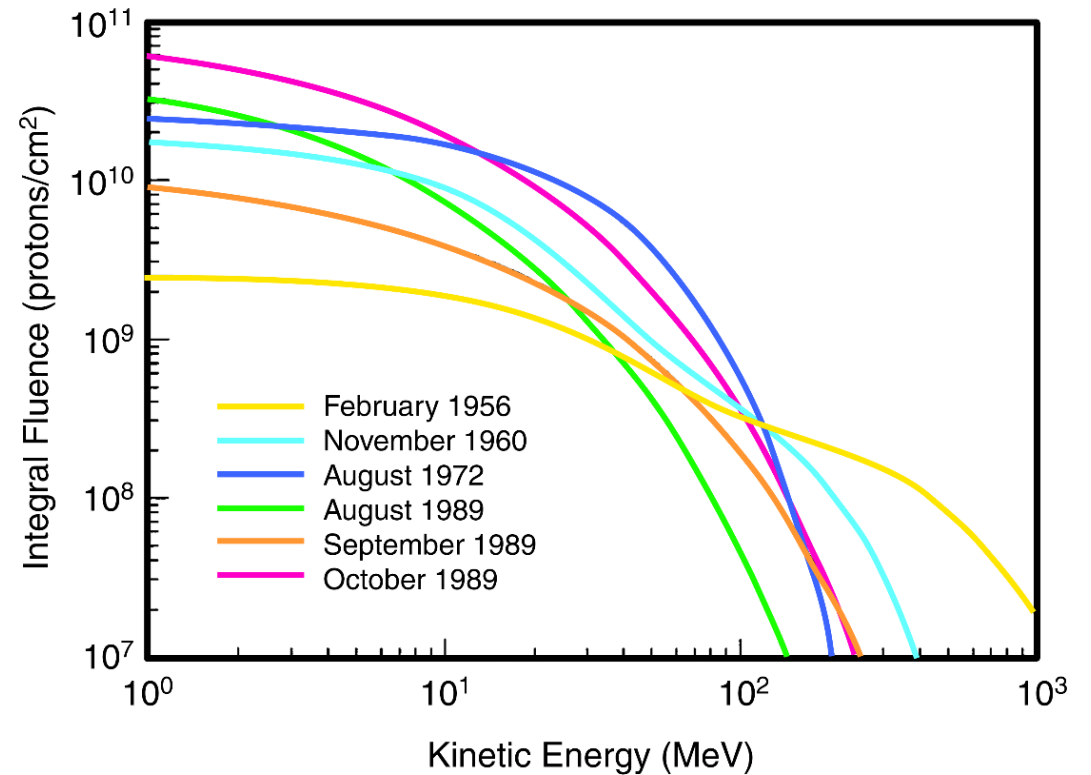

J.W. Wilson et al., Radiat. Meas., 1999

# Worst Case Solar Particle Event Model CREME96

- **Standard CREME96 model based on October 1989 event**
  - Peak 5 minutes
  - Worst day
  - Worst week
- **Useful for both protons and heavy ions**
- **QinetiQ's CREDO experiment measured 3 events during solar cycle 23 approaching the "worst day" model.**

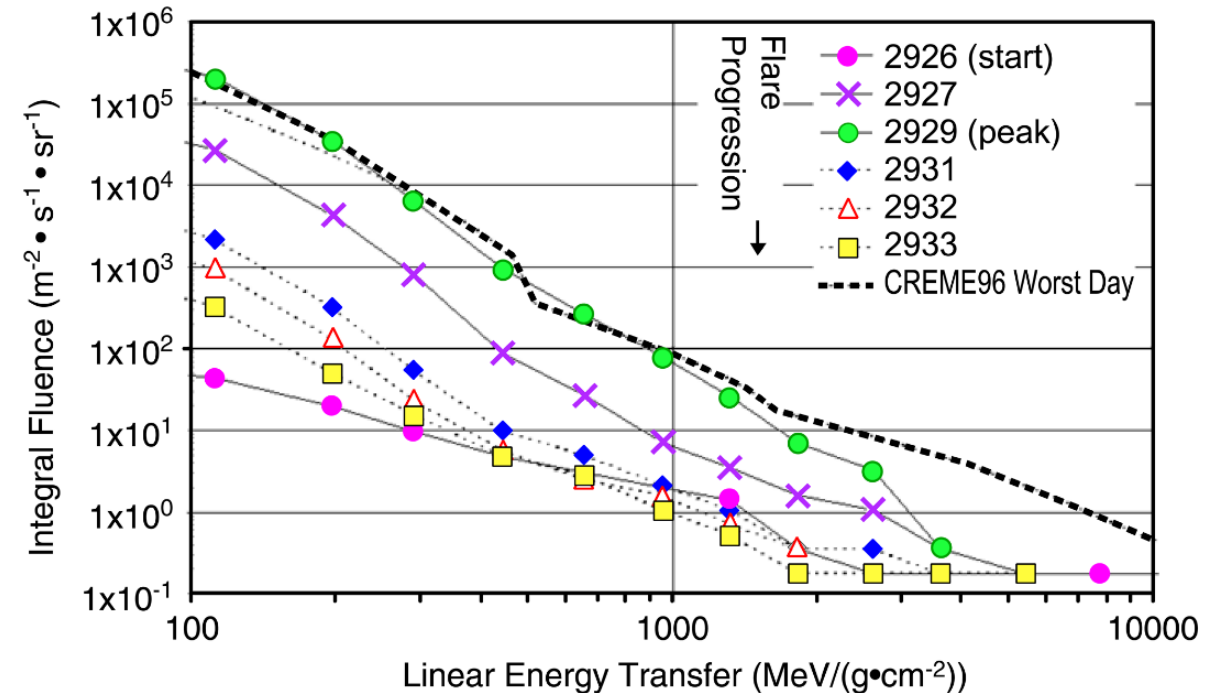

C.S. Dyer et al., IEEE TNS, Dec. 2002

# Extreme Value Statistics

- Usual central value statistics characterizes the distribution of a random variable using mean value and standard deviation
- Extreme value statistics focuses on largest (or smallest) values of the distribution
  - Pioneered by E. Gumbel
  - Initially applied to environmental phenomena such as earthquakes and floods
  - First applied to radiation effects problems by P. Vail, E. Burke and J. Raymond

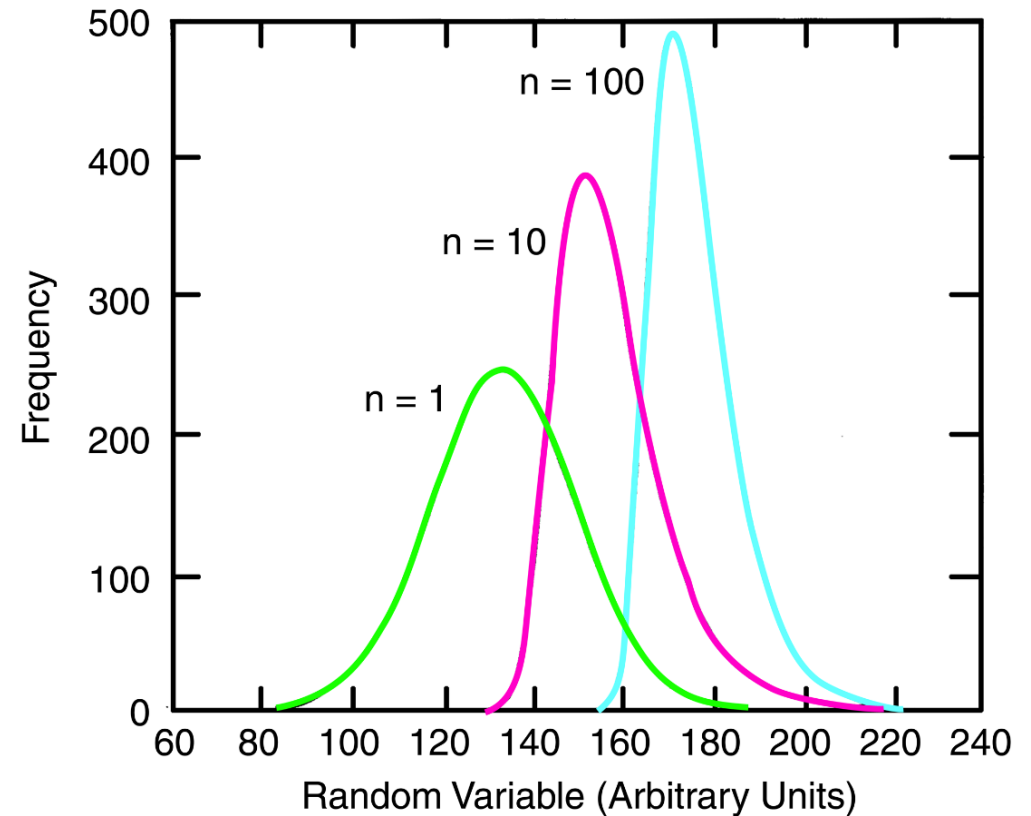

E.A. Burke et al., IEEE TNS, Dec. 1988

# Extreme Value Example Problem

## Process Distributions

- Suppose a threshold voltage adjust implant is used in an array of  $10^6$  NMOS transistors to tune  $V_t$ .
- Limited measurements show a Gaussian distribution of  $V_t$  with a mean of 700 mV and standard deviation of 5.1 mV.
- What is the expected minimum and maximum  $V_t$  for  $10^6$  transistors?
  - 676 mV and 724 mV

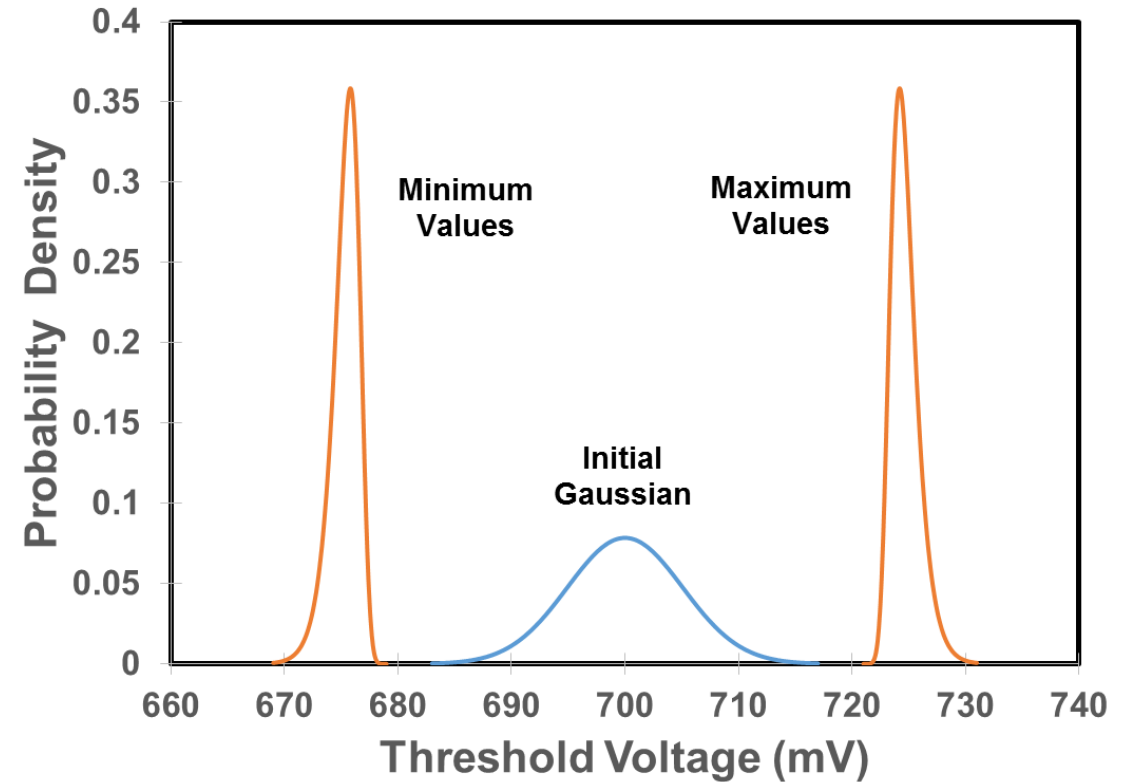

M.A. Xapsos, IEEE TNS, Dec. 1996



# Worst Case Proton Model Event Magnitude Distribution

- **Maximum Entropy Principle leads to complete description of event magnitudes**
  - Mathematical procedure for selecting probability distribution when data are limited
- **Essential features of resulting distribution:**
  - Smaller event sizes follow power law function
  - Rapid falloff of larger event sizes
  - Note October 1989 event used in CREME96
- **This initial distribution is used to obtain a statistical worst case model.**

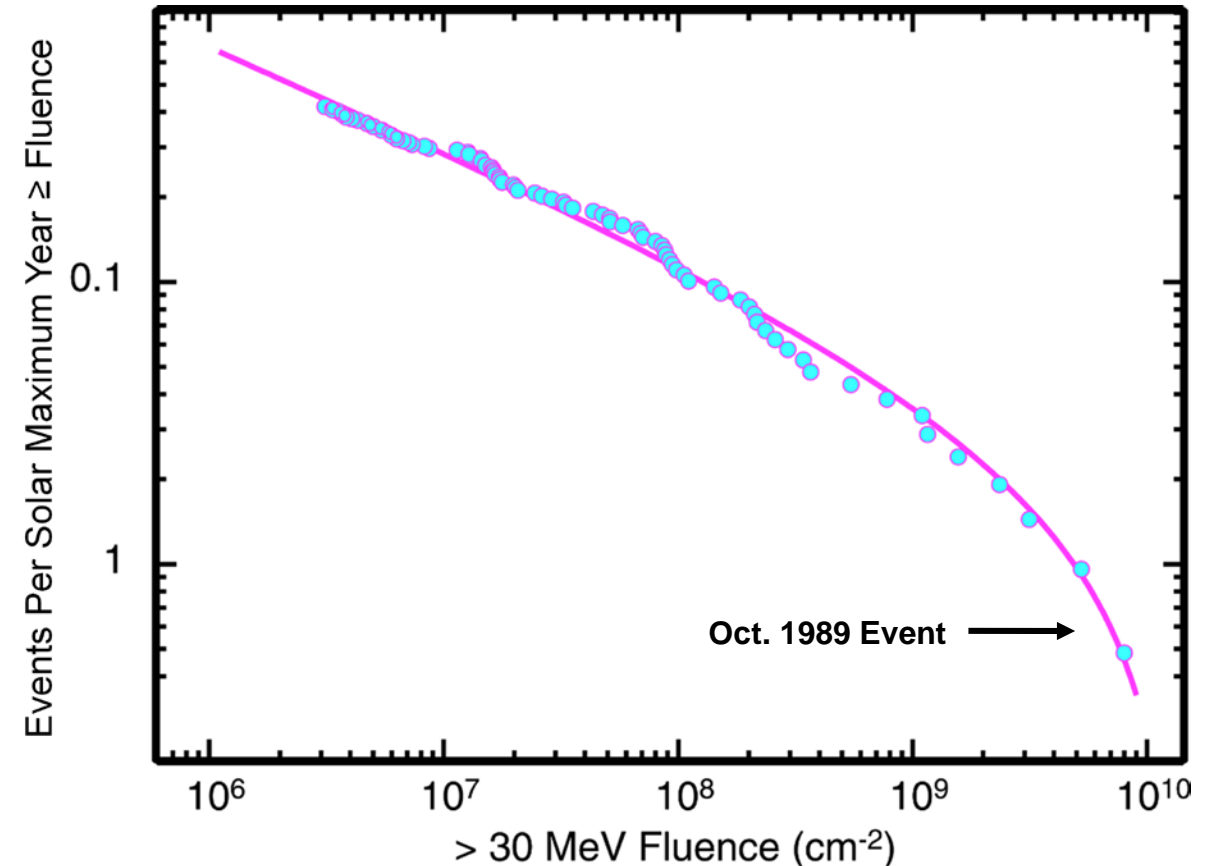

M.A. Xapsos et al., IEEE TNS, Dec. 1999



# Worst Case Proton Model ESP/PSYCHIC

- **Given the initial distribution of event magnitudes, extreme value theory is used to calculate worst case events as function of confidence level and mission duration**
  - Peak flux
  - Event fluence
- **“Design limit” is statistical upper limit**
  - Engineering feature

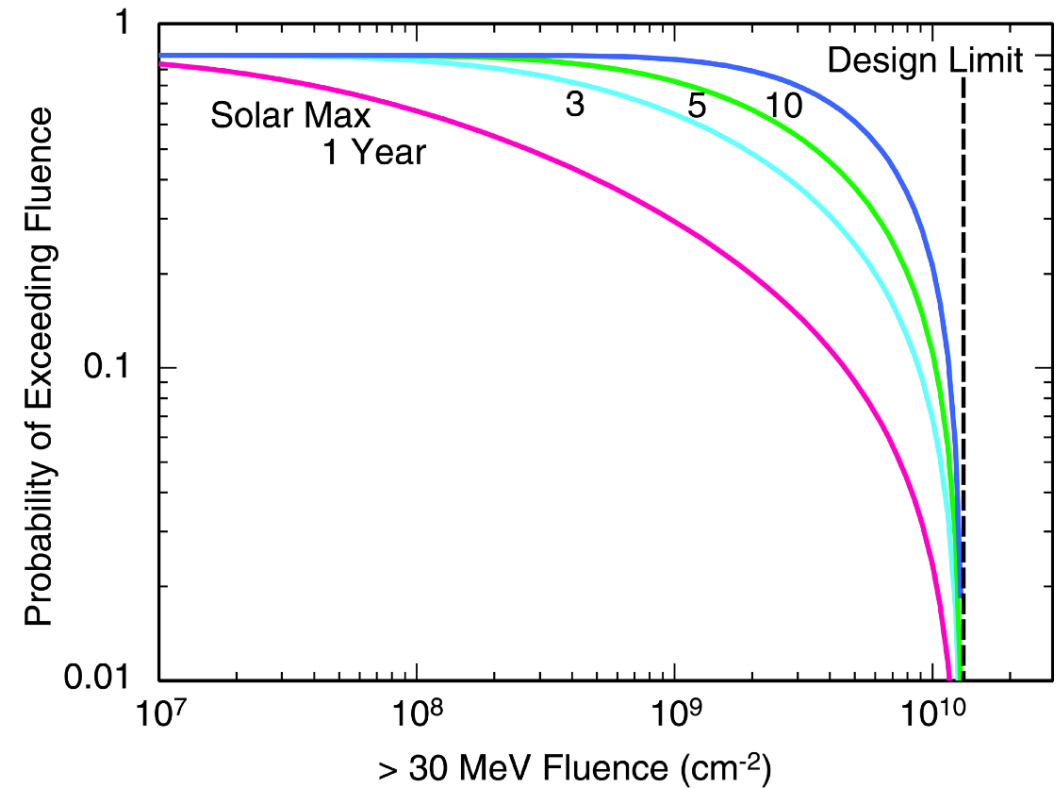

M.A. Xapsos et al., IEEE TNS, Dec. 1999



# Use of a Statistical Model vs. Worst Case Observation

## • Statistical Model

- Uses the entire data base of events but heavy ion data are limited
- Proton and heavy ion models are independent
- Allows risk / cost / performance trades
- Heavy ion models are a developing area
  - SAPPHIRE model based on Monte Carlo approach
  - Robinson / Adams model builds on ESP / PSYCHIC approach

## • Worst Case Observation

- Based on a single well characterized event
  - October 1989 “standard”
- Proton and heavy ion models are self-consistent
- Little design flexibility; very severe environment
- Long history of use

# Outline: Trapped Particles

- **Trapped Particle Motion in the Magnetosphere**
  - L-shell Parameter
- **Trapped Protons**
  - Properties
  - Models – AP8 and AP9/IRENE
- **Trapped Electrons**
  - Properties
  - Models – AE8 and AE9/IRENE
    - Outer Belt
    - Slot Region
    - Inner Belt
      - **Current Issue: The Case of the Missing Electrons**

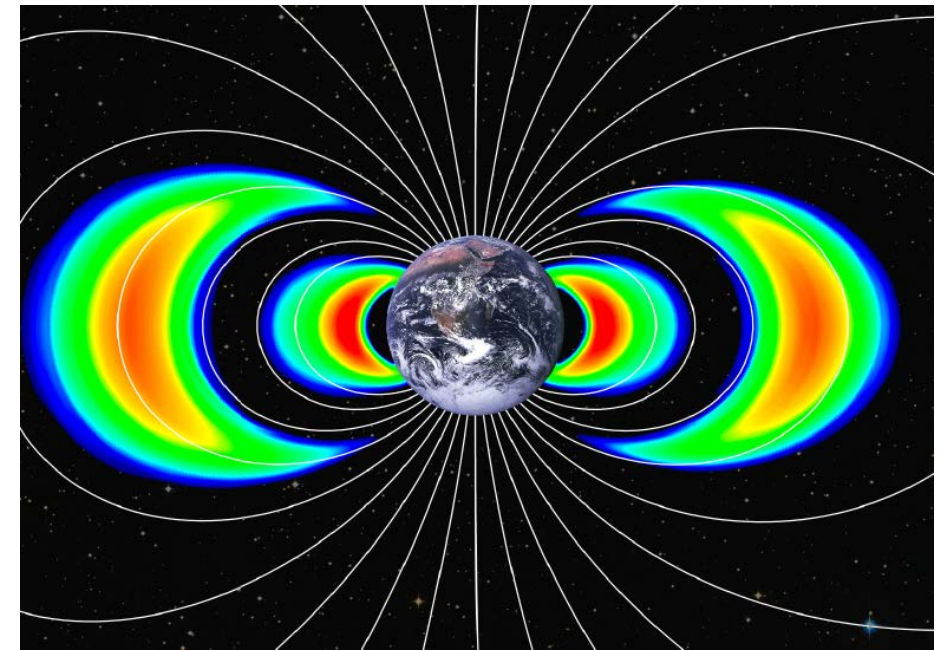

Credit: NASA and Johns Hopkins U. Applied Physics Lab

# Earth's Internal Magnetic Field

- **Geomagnetic field is approximately dipolar for altitudes up to about 4 to 5 Earth radii**
- **Dipole axis is not same as geographic North-South axis**
  - 11.5 degree tilt
  - ~500 km displacement
- **Trapped particle populations conveniently mapped in dipole coordinate systems**

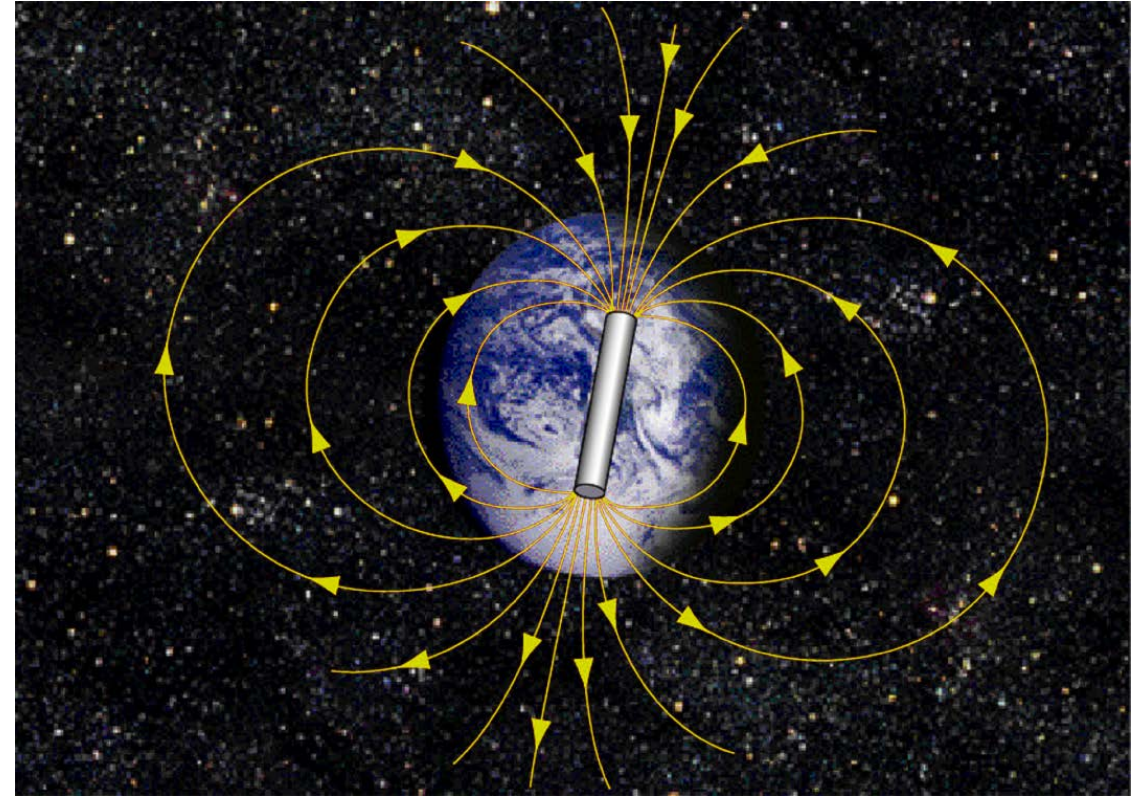

Credit: ESA

# Charged Particle Motion in Magnetic Field

- **Equation of force**
  - $F = qv \times B$
- **For a uniform field**
  - 2 dimensions – circular motion
  - 3 dimensions – helical or spiral motion
- **Increasing B-field strength results in a smaller radius of curvature**

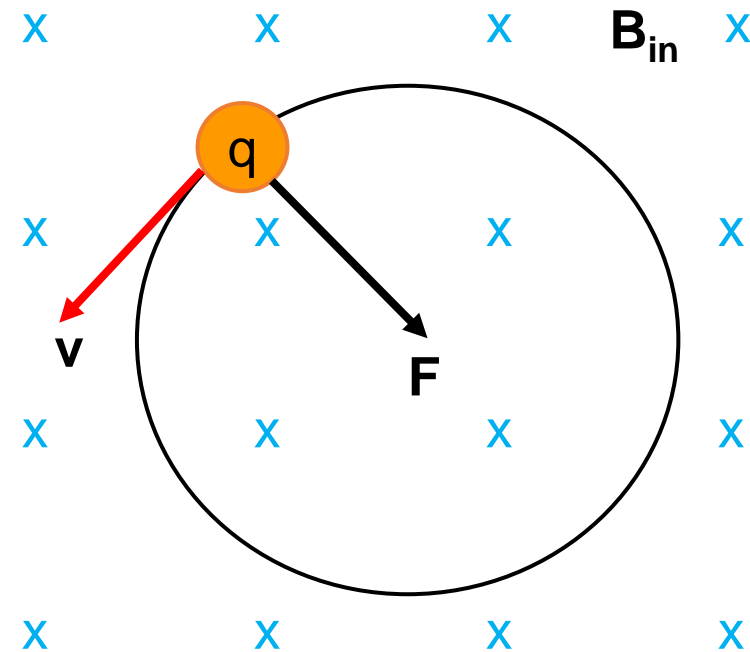

# Trapped Charged Particle Motion

- **In Earth's magnetic field**
  - Particles spiral along magnetic field lines
  - Increased field strength in polar region causes particle spiral to tighten and then reverse direction along magnetic field line at "mirror point"
  - Radial gradient in magnetic field causes slow longitudinal drift around Earth
  - A complete azimuthal rotation of particle trajectory traces out a drift shell or **L-shell**.

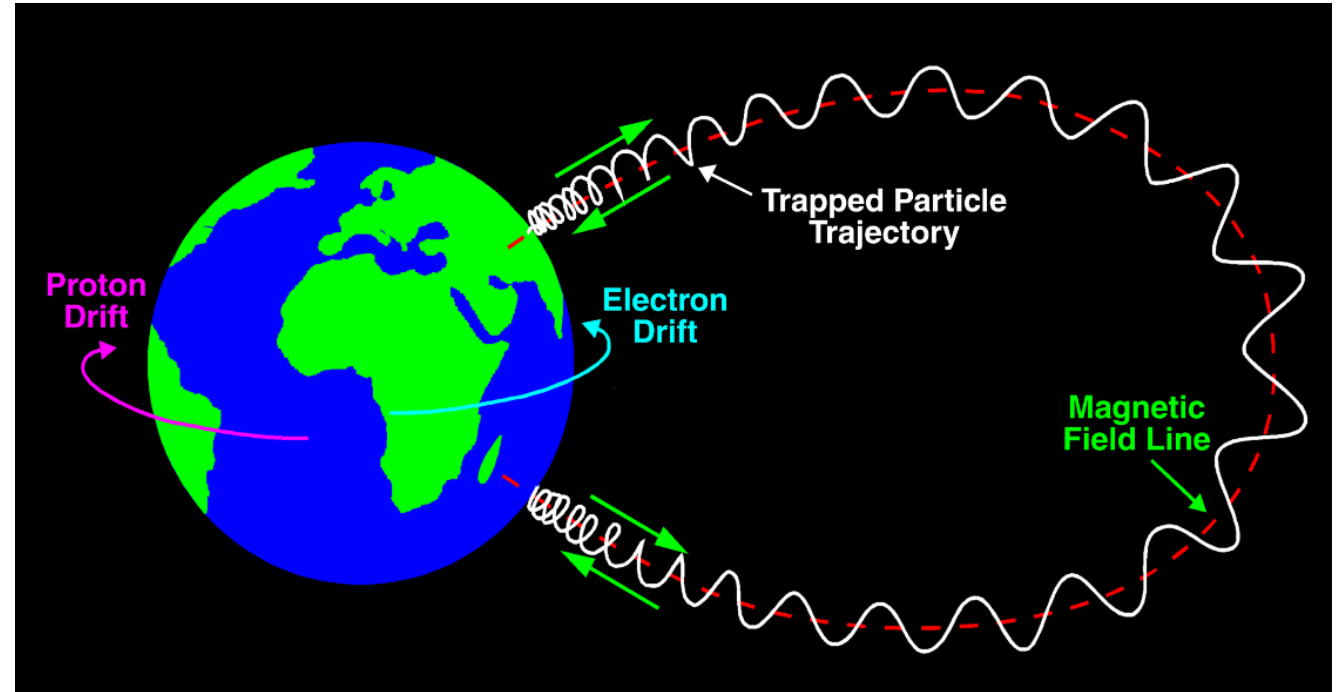

J.L. Barth, 1997 NSREC Short Course,  
after E.G. Stassinopoulos



# The L-Shell Parameter

- **L-shell parameter indicates magnetic equatorial distance from Earth's center in number of Earth radii and **represents the entire drift shell.****
- **An L-shell contains a subset of trapped particles peaked at a certain energy moving throughout this shell.**
- **Provides convenient global parameterization for a complex population of particles**

# Trapped Proton Properties

- **Single trapped proton region for “quiet” conditions**
- **L-shell values range up to ~10**
  - Especially important for  $L < 4$
  - $> 10$  MeV fluxes peak at  $\sim 10^5 \text{ cm}^{-2}\text{s}^{-1}$  near  $L = 1.7$
- **Earth’s atmosphere limits belt to altitudes above ~200 km**
- **Energies up to ~GeV**

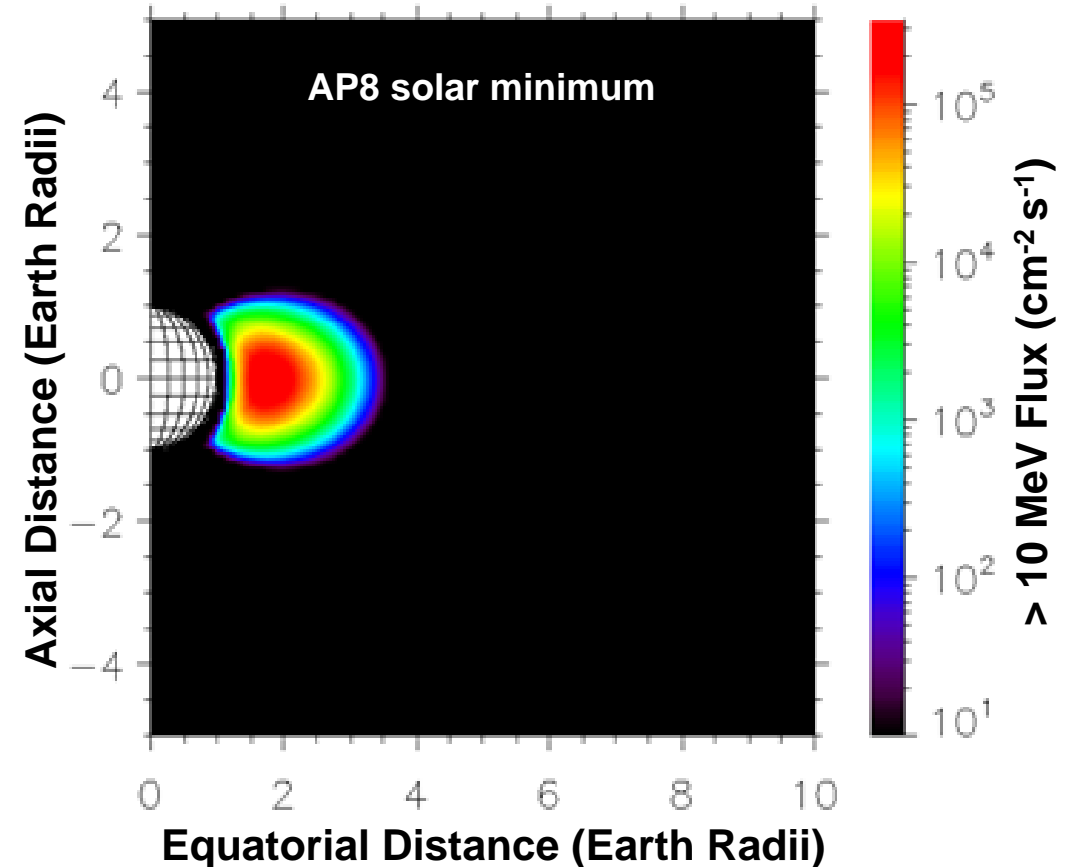

S. Bourdarie and M.A. Xapsos, IEEE TNS, Aug. 2008

# Solar Cycle Modulation - Protons

- **Fluxes generally anti-correlated with solar cycle activity**
  - Most pronounced near belt's inner edge
- **During solar maximum**
  - Increased loss of protons in upper atmosphere
  - Decreased production of protons from Cosmic Ray Albedo Neutron Decay (CRAND) process

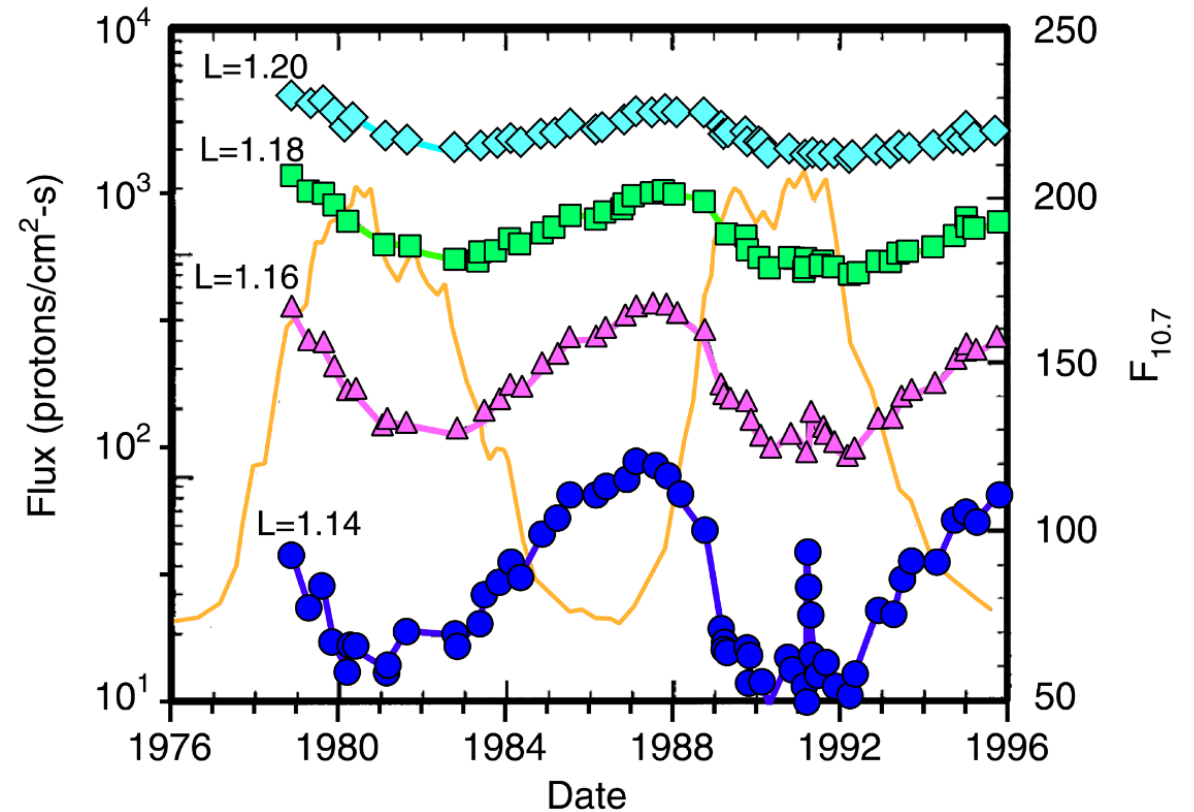

S.L. Huston and K.A. Pfitzer, IEEE TNS, Dec. 1998



# South Atlantic Anomaly

- **Generally dominates the radiation environment for altitudes less than about 1000 km**
- **Caused by tilt and shift of geomagnetic axis relative to rotational axis**
- **Inner edge of proton belt is at lower altitudes in vicinity of South America**

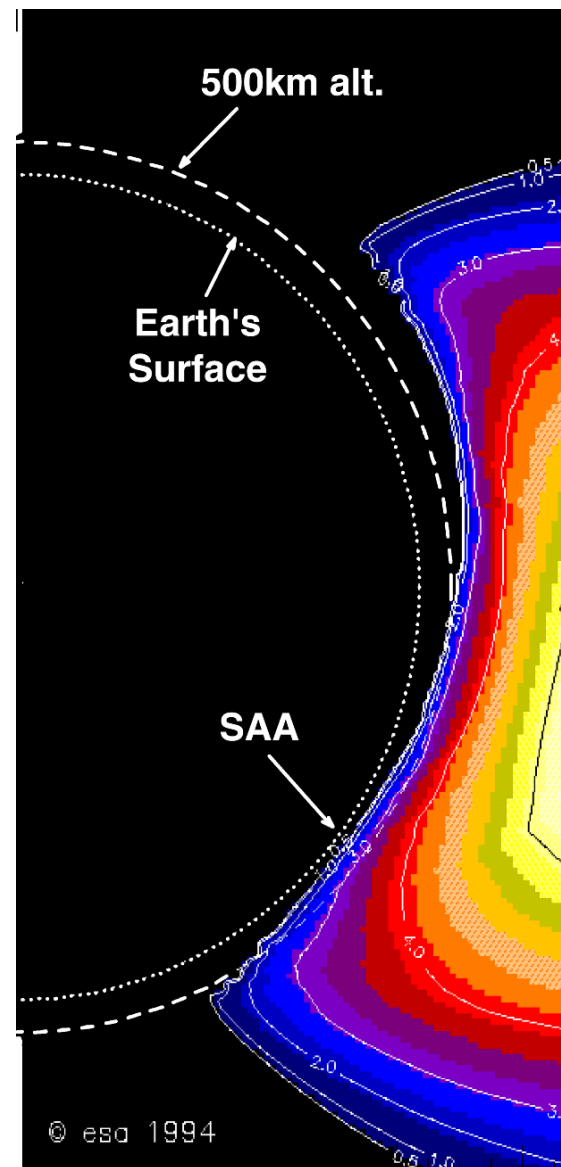

E.J. Daly et al., IEEE TNS, April 1996



# South Atlantic Anomaly

- **Measurements of the mean >35 MeV proton flux at ~840 km from the Polar Orbiting Earth Satellite (POES) over a 13 year period from July 1998 to December 2011**

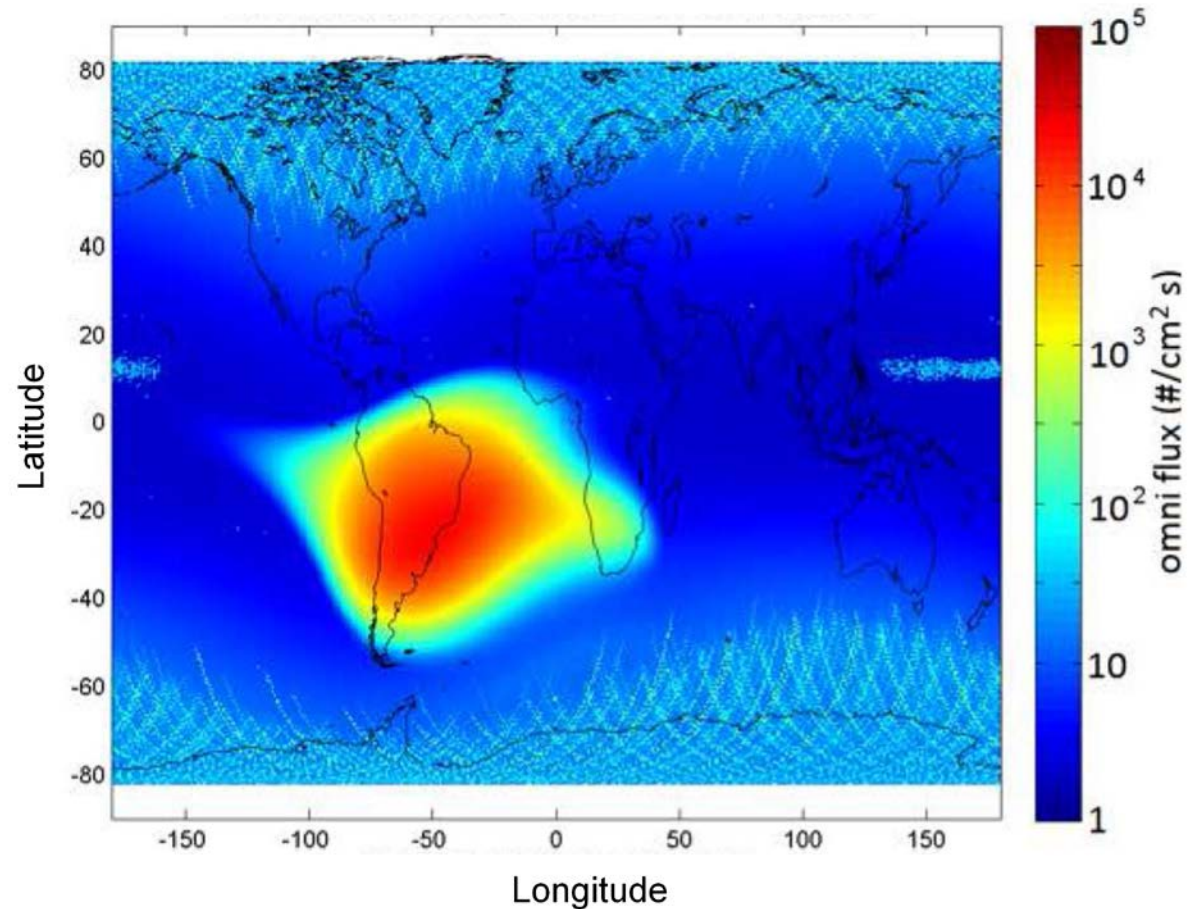

W.R. Johnston et al., IEEE TNS, Dec. 2015

# Extreme Events in the Proton Belt

- Higher energy ( $> 10$  MeV) trapped protons generally fairly stable
- During 1990-1991 CRRES mission, AFRL group discovered formation of transient proton belt in L-shell 2 to 3 (slot) region.
- CMEs can cause geomagnetic storms that suddenly reconfigure belt:
  - Enhanced fluxes if preceded by flare or CME
  - Enhanced flux can be reduced

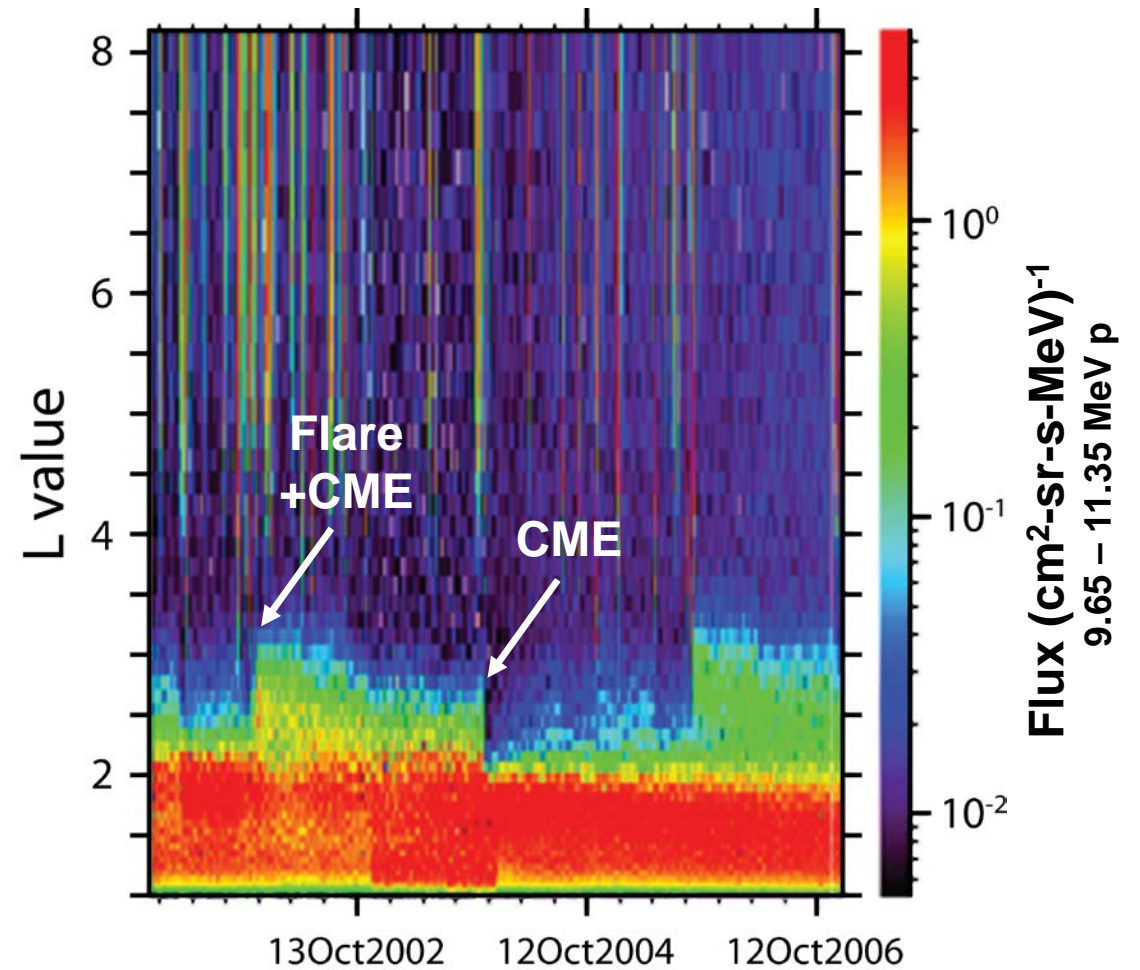

S. Bourdarie and M.A. Xapsos, IEEE TNS, Aug. 2008



# Trapped Particle Models

- **General approach**
  - **Use an orbit generator code to calculate geographical coordinates (latitude, longitude, altitude)**
  - **Transform the geographical coordinates to dipole coordinate system in which particle population is mapped**
  - **Determine trapped particle environment external to spacecraft**



# Trapped Particle Models

- **AP8/AE8**

- **Static model for mean environment**
- **Based on data from 1960s and 1970s**
- **Approximate solar cycle dependence**
  - **Solar maximum**
  - **Solar minimum**
- **Results in use of Radiation Design Margin (RDM) for design specifications**

- **AP9/AE9/IRENE**

- **Statistical model for mean or percentile environment**
- **Perturbed model adds measurement uncertainty and gap-filling errors**
- **Monte Carlo adds space weather variations**
- **Based on data from 1976 – 2016**
  - **~10x that of AP8/AE8 based on instrument years**
- **Output averaged over solar cycle**
- **Allows capability to use confidence levels for design specifications**



# Comparison of AP8 and AP9/IRENE Polar Low Earth Orbit

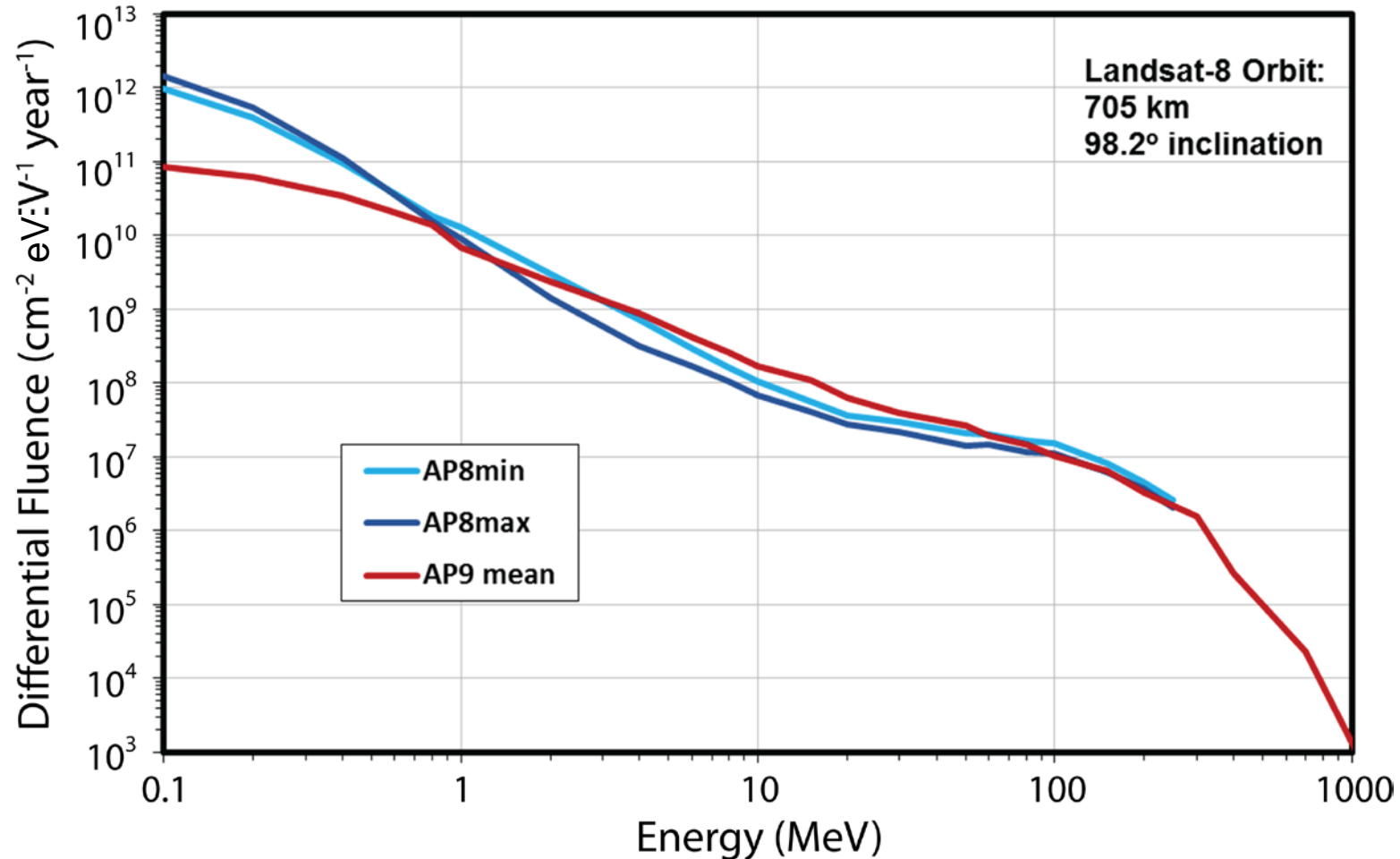

# Trapped Electron Properties

- **Outer Zone ( $L > 3$ )**
  - Very dynamic
  - Energies up to  $\sim 10$  MeV
- **Slot Region ( $L = 2$  to  $3$ )**
  - Between the two zones where fluxes are at local minimum during quiet periods
- **Inner Zone ( $L < 2$ )**
  - Energies up to  $\sim 5$  MeV

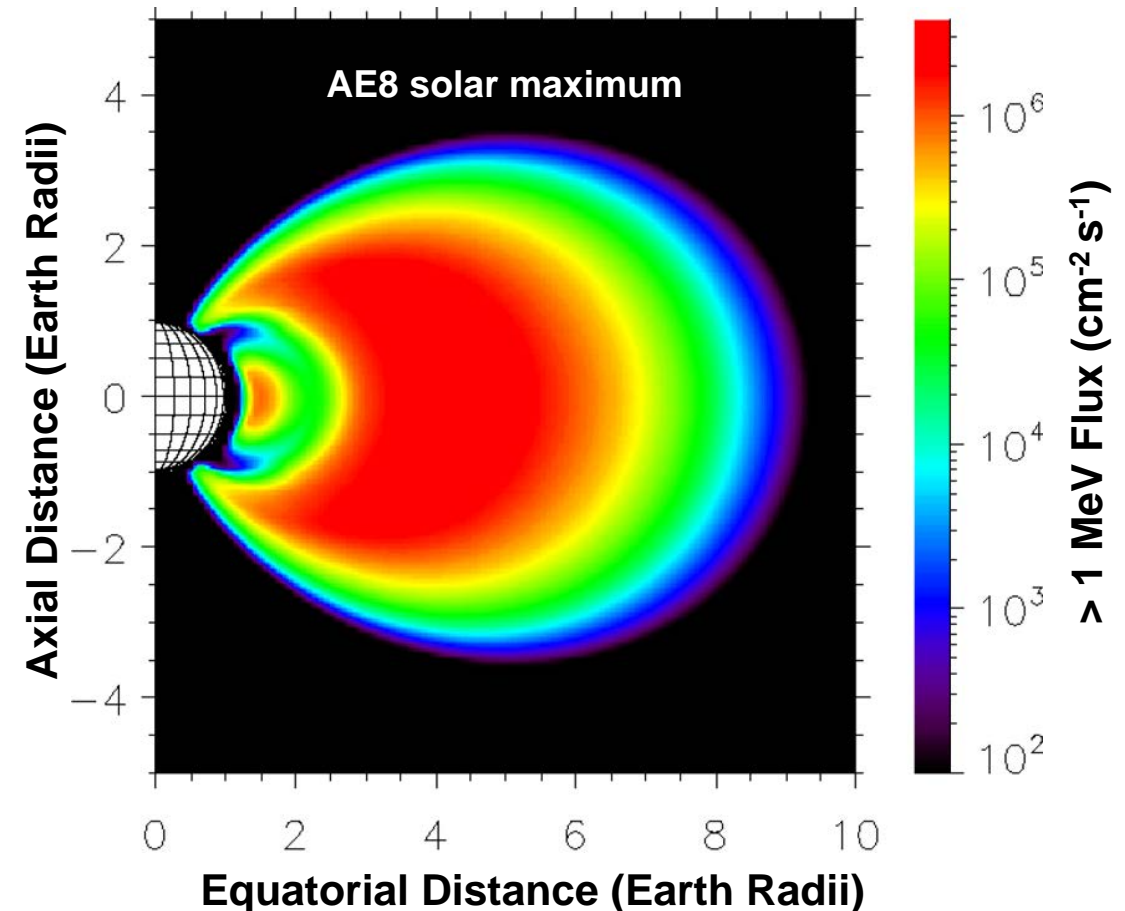

S. Bourdarie and M.A. Xapsos, IEEE TNS, Aug. 2008

# Outer Zone Volatility

- **Outer zone features highly variable electron fluxes**
- **Caused by magnetic storms and substorms, which perturb geomagnetic field**
- **Results in injection and redistribution of trapped electrons**

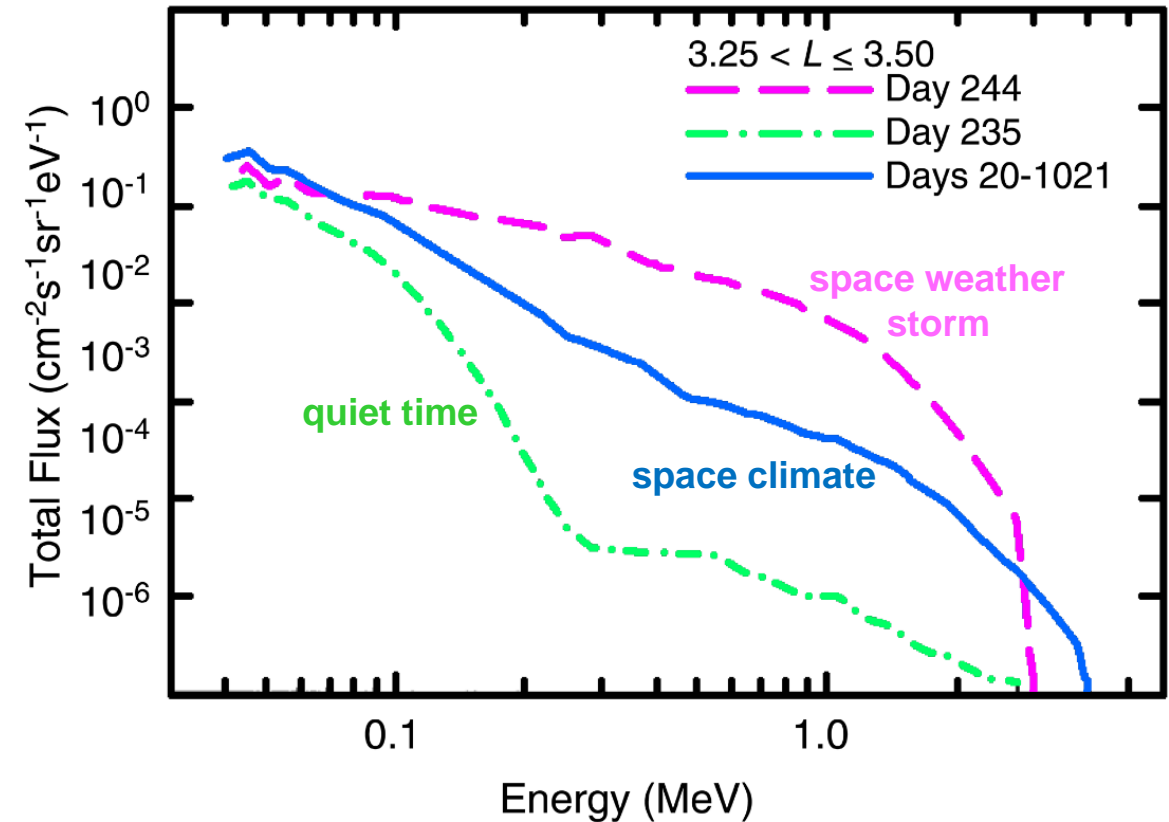

W.D. Pesnell, IEEE TNS, Dec. 2001



# Comparison of AE8 and AE9/IRENE Geostationary Earth Orbit

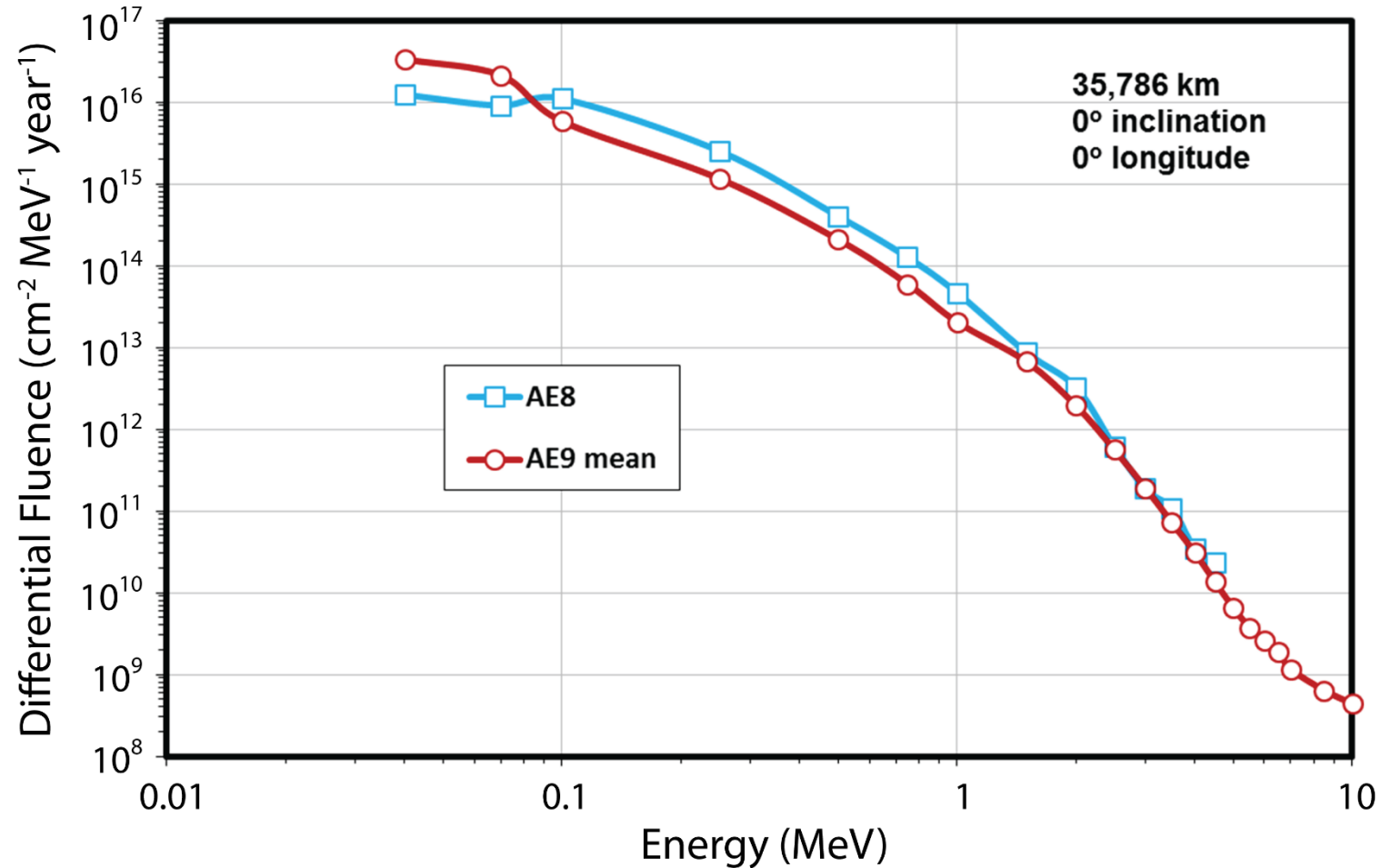

# Van Allen Belts < 0.75 MeV Electrons

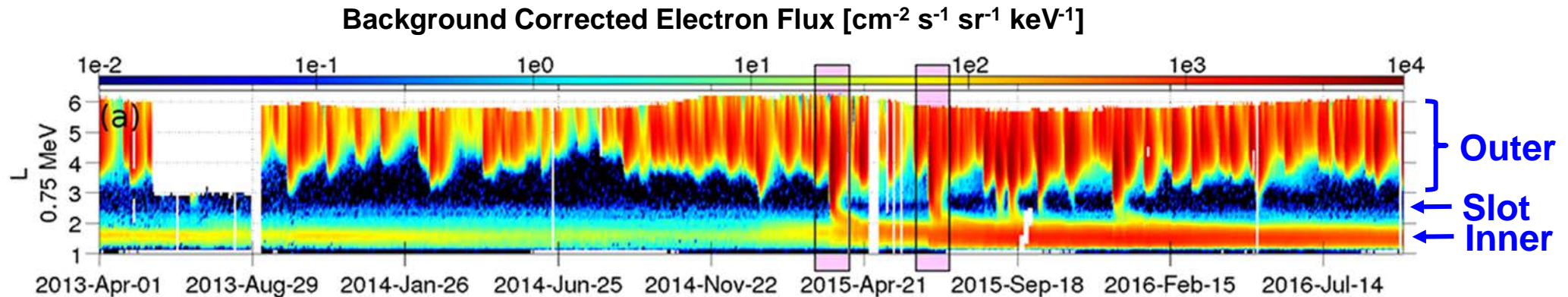

S.G. Claudepierre et al., J. Geophys. Res.: Sp. Phys, March 2017

- **Modern instrumentation on Van Allen Probes mission provides a good overview of belt dynamics:**
  - **High intensity and volatility of outer zone**
  - **During magnetic storms electrons can be injected into:**
    - **slot region but decay away on order of tens of days**
    - **inner zone and are much more stable**



# Van Allen Belts > 1.5 MeV Electrons

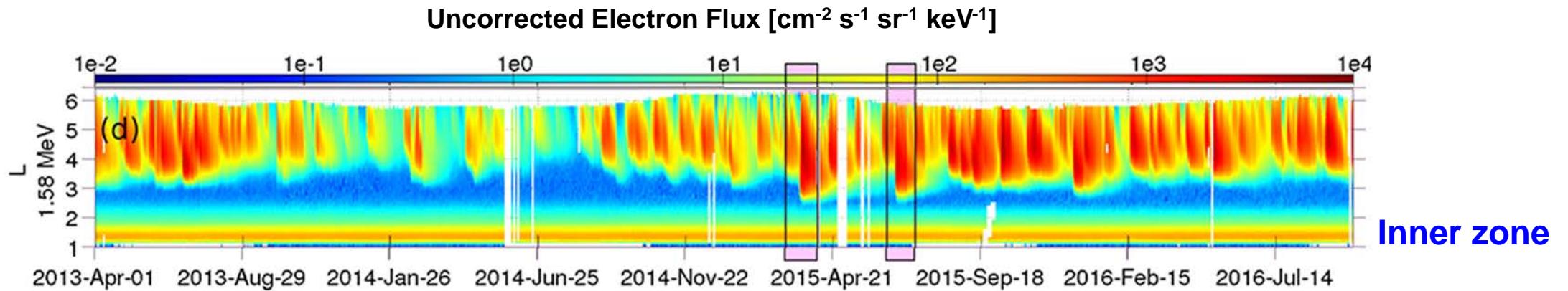

S.G. Claudepierre et al., J. Geophys. Res.: Sp. Phys, March 2017

- **Inner zone electrons:**
  - > 1.5 MeV fluxes appear to be stable
  - AE8 and AE9 / IRENE model calculations show significant electron fluxes between 1.5 and about 5 MeV.
  - However, note the figure is uncorrected for background contamination.



# Inner Zone: $> 1.5$ MeV Electrons The Case of the Missing Electrons

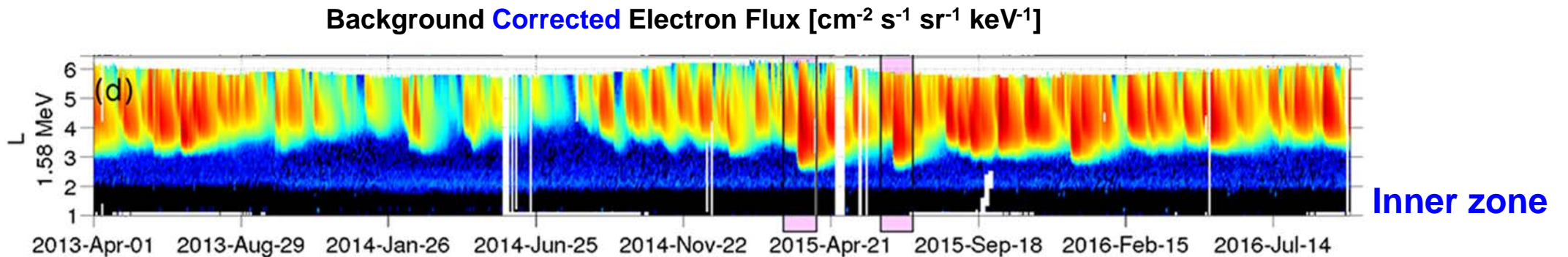
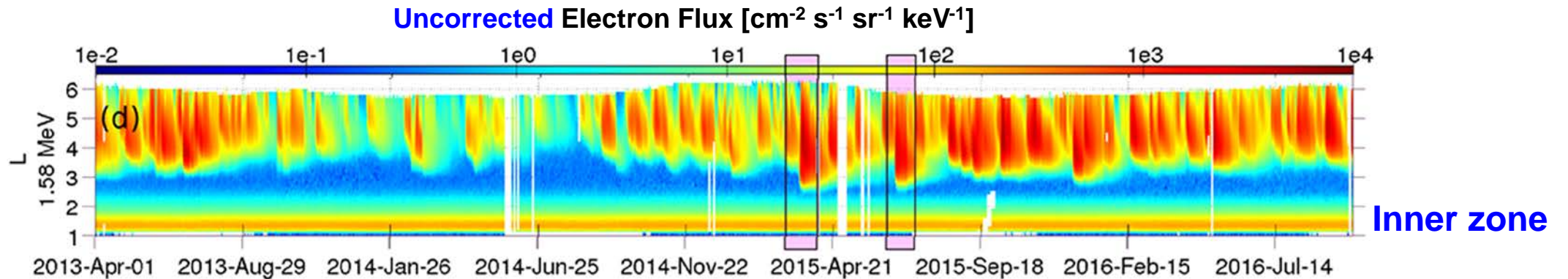

S.G. Claudepierre et al., J. Geophys. Res.: Sp. Phys, March 2017

- **No evidence of  $> 1.5$  MeV electrons in the inner zone has been seen by Van Allen Probes since the 2012 launch**



# Inner Zone: $> 1.5$ MeV Electrons

## The Case of the Missing Electrons

- **What happened to this portion of the inner zone?**
- **Possible explanations:**
  - **Difficulty in subtracting background contamination in earlier instrumentation**
    - High energy protons in inner zone are main contaminant.
  - **This may reflect a difference in time periods**
    - Injection of  $> 1.5$  MeV electrons into inner zone may require extreme magnetic storms.
    - Magnetic storms during Van Allen Probes era have been fairly mild.



# Comparison of AE8 and AE9/IRENE Low Inclination Low Earth Orbit

- AE8 consists of older data
- AE9/IRENE, version 1.5, consists of Van Allen Probes and CRRES data.
  - CRRES data contains March 1991 storm
- Although an interesting scientific challenge, inner belt electrons are unlikely to drive radiation effects problems except possibly surface effects
  - For 2.5 mm Al shielding, electrons in Hubble Space Telescope (HST) orbit contribute:
    - < 20% of TID (AP8/AE8)
    - < 2% of TID (AP9/AE9/IRENE)

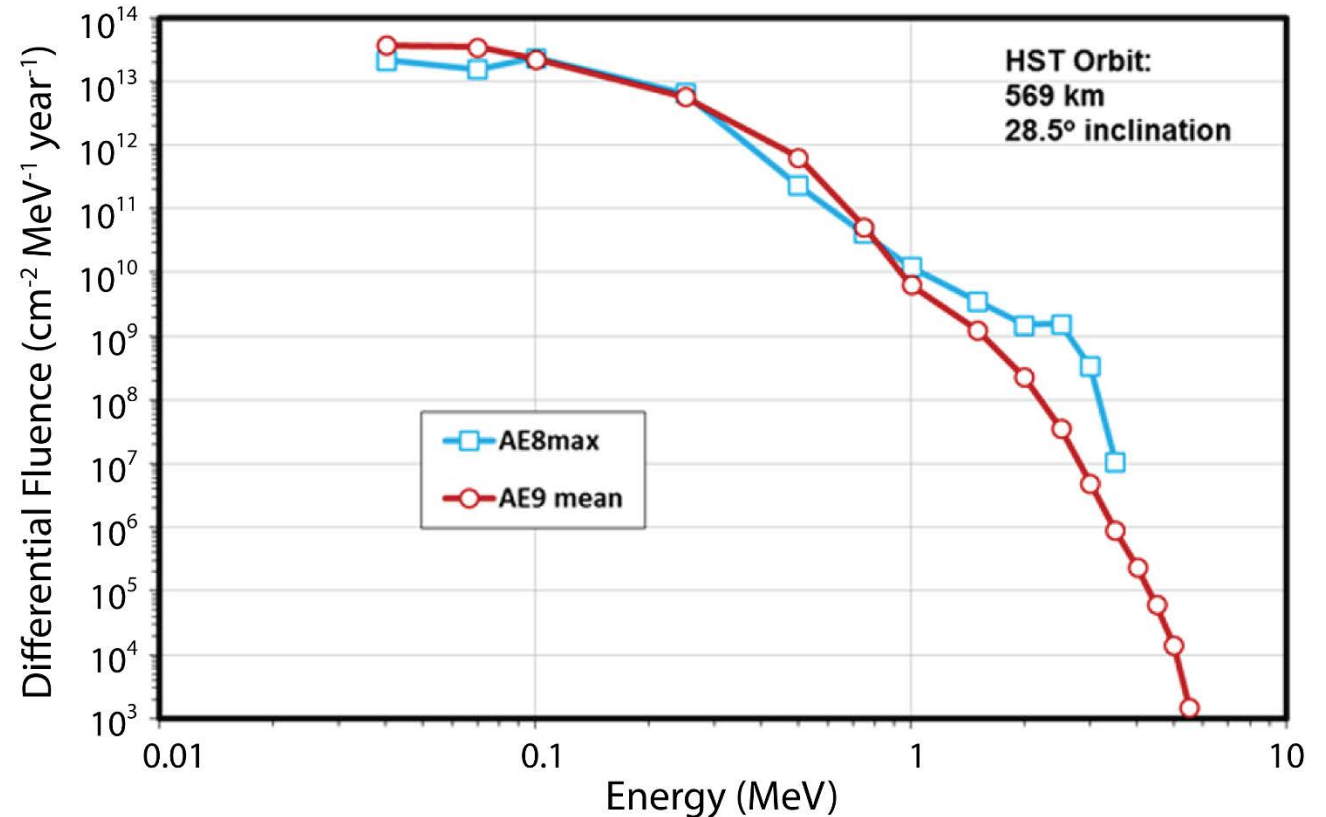

# Example Environment Total Ionizing Dose

- **Consider Highly Elliptical Orbit**
  - For TID must account for trapped protons and electrons, and solar protons.
  
- **Two options for building conservatism into design**
  - **Margin based approach**
    - AP8, AE8, ESP used; apply x2 margin
  - **Confidence level based approach**
    - AP9, AE9, ESP used at 95% confidence level
  - **Dose-depth curves at 95% confidence level are fairly consistent with using x2 margin for various orbits.**

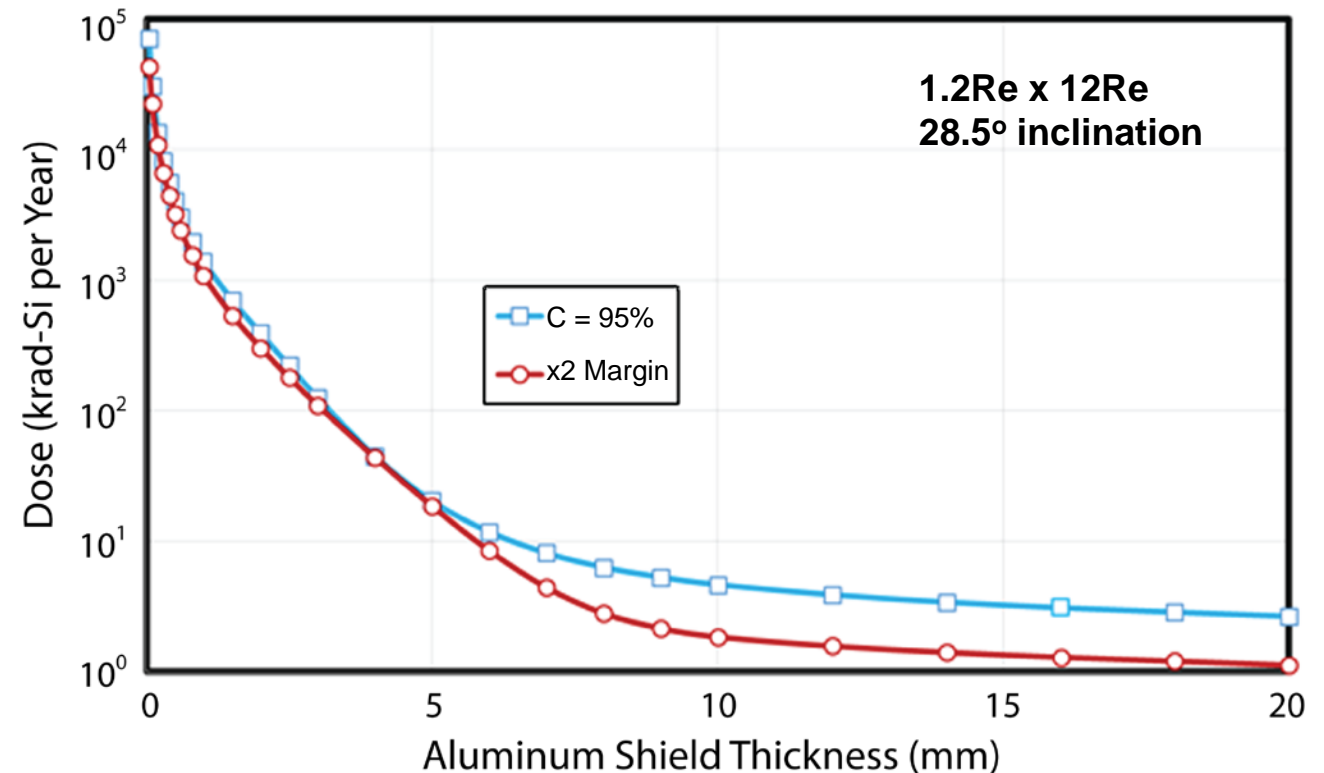

# Example Environment Total Ionizing Dose

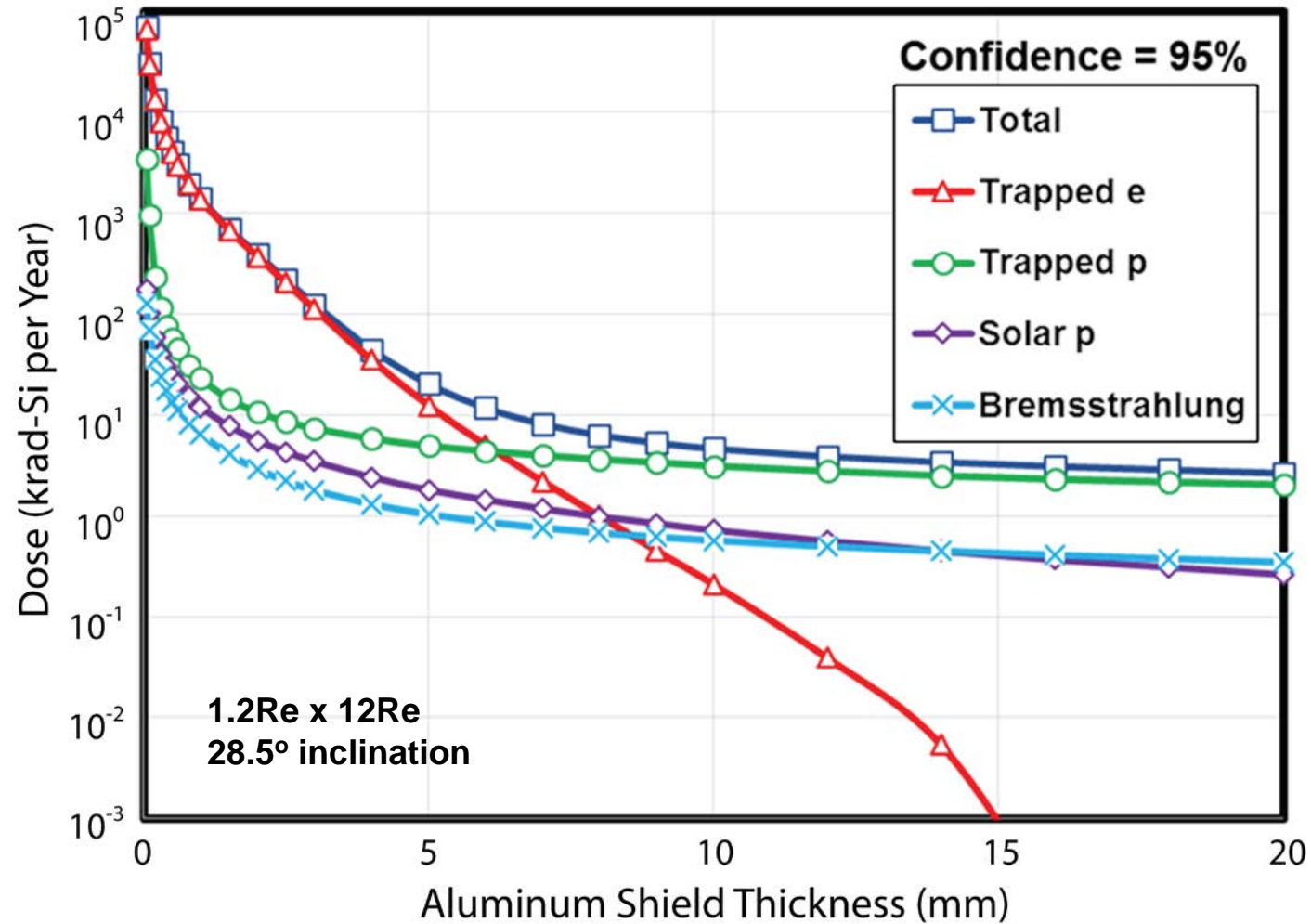

# TID Failure Probabilities SFT2907A Bipolar Transistor

- **When convolved with laboratory test data the confidence level based approach allows device failure probability to be calculated for the mission.**
  - **Better characterization of device radiation performance in space**
  - **Allows more systematic trades during design (device performance, cost, shielding level, etc.)**

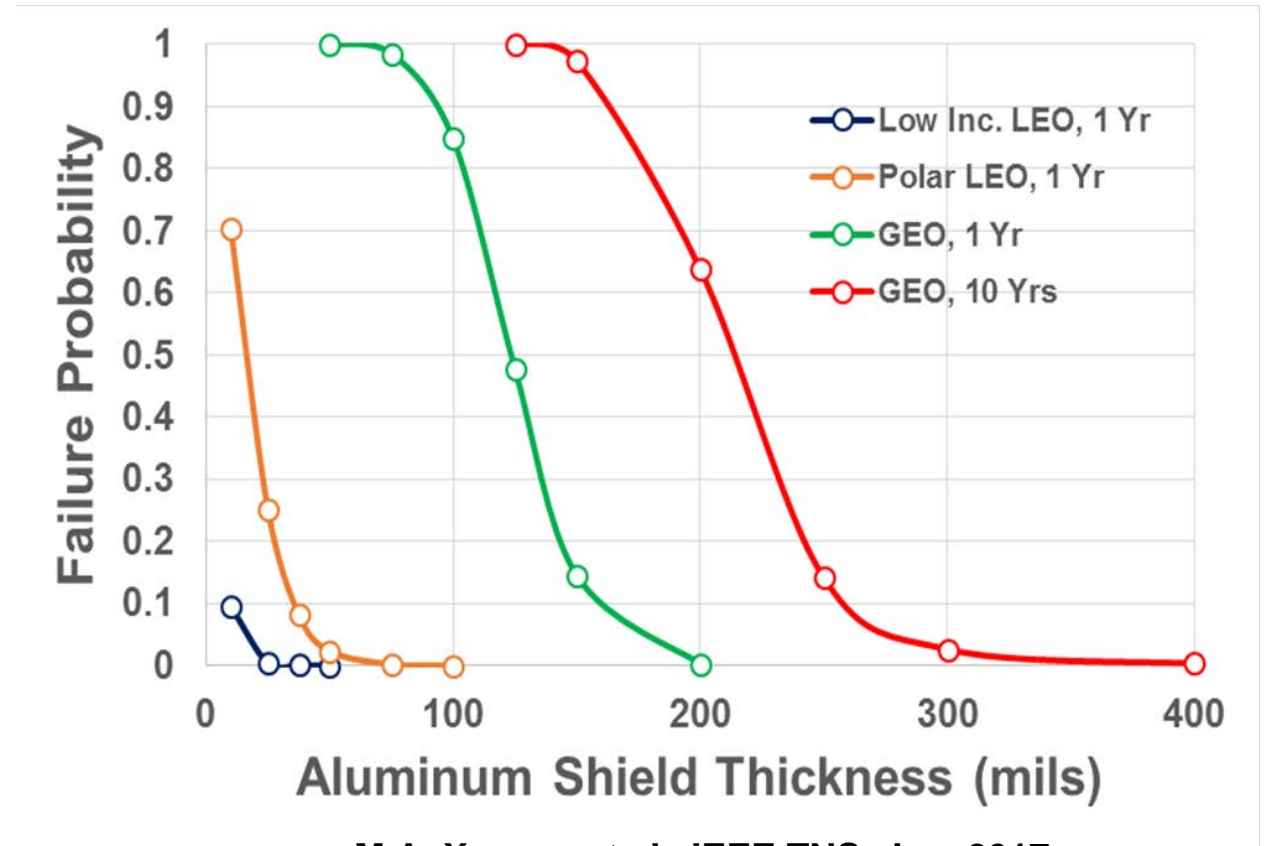

M.A. Xapsos et al., IEEE TNS, Jan. 2017



# Example Environment Measured Single Event Upsets

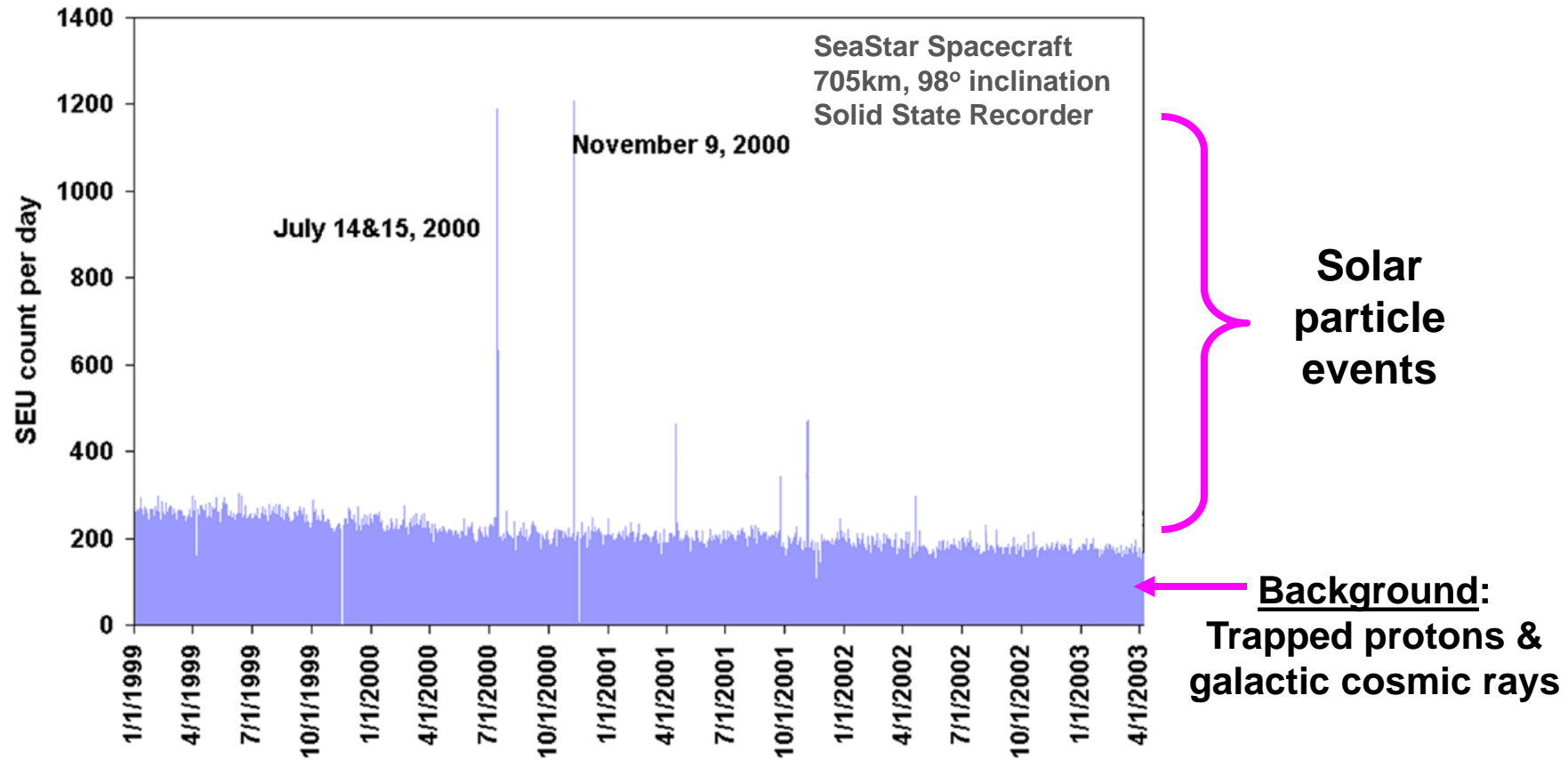

C. Poivey, et al., SEE Symposium, Los Angeles, CA, April 2002

# Example Environments Single Event Upset

- Consider same Highly Elliptical Orbit
  - For SEE must account for solar heavy ions and galactic cosmic rays
  - Additionally solar and trapped protons for sensitive devices
- SEU rate calculated for 4 Gbit NAND flash memory
- Shielding can reduce rates during solar events and for trapped protons.
- GCR rate provides a lower limit for SEU.

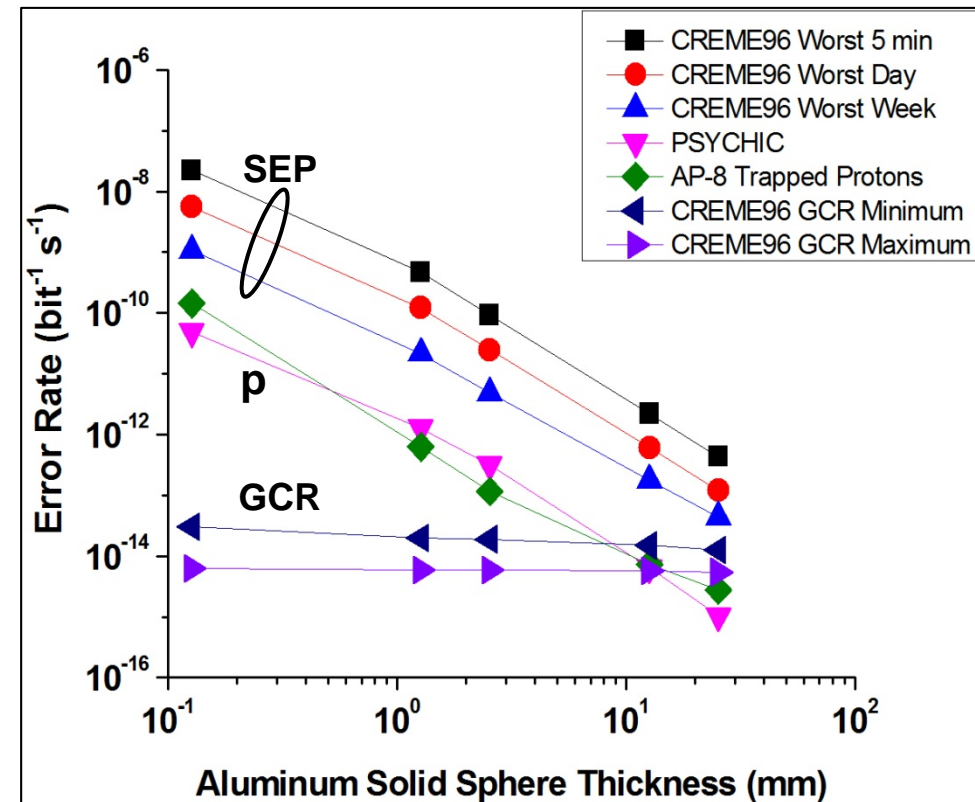

J.A. Pellish et al., IEEE TNS, Dec. 2010



# Summary

- **A space climatology timeline was presented ranging from the Big Bang to NSREC 2018.**
  - **It began with a description of the early universe, the origin and abundances of particles significant for radiation effects.**
  - **It continued to a transition period to modern times about sunspots and the solar activity cycle.**
  - **It concluded with description of the modern era covering galactic cosmic rays, solar particle events and the Van Allen belts**
- **A general theme is that the space radiation environment is highly variable and must be understood to produce reliable, cost-effective designs for successful space missions**
  - **Long-term variations of space climate**
  - **Short term variations of space weather**