



Increment 59/60 Science Symposium

Advanced Colloids Experiment (Temperature controlled) – ACE-T11

PI: Professor Boris Khusid – New Jersey Institute of Technology (NJIT)

Co-PI: Professor Paul M. Chaikin – New York University (NYU)

Co-PI: Professor Andrew D. Hollingsworth - NYU



Presented by:

Dr. William V. Meyer (a.k.a. Bill Meyer)

ACE NASA Project Scientist

USRA at NASA GRC, Tel: (216) 433-5011, Email: William.V.Meyer@NASA.Gov

ACE NASA Project Manager: Ron Sicker, Tel.: (216) 433-6498

ZIN-Technologies ACE Project Manager: Michael Bohurjak, Tel: (440) 625-2264

ZIN-Technologies Science Lead: John Eustace, Tel: (440) 625-2244

February 12 - 14, 2019





ISS INCREMENTS 59/60 SCIENCE SYMPOSIUM

- Science Background and Hypothesis
- Investigation goals and objectives
- Measurement approach
- Importance and reason for ISS
- Expected results and how they will advance the field
- Earth benefits/spin-off applications



ACE-T11 NJIT & NYU Science Team Members



Key Personnel [Affiliation] / Role	Contact Information
Boris Khusid PI / Provide flight samples, science requirements, and data analysis	Professor of Chemical Engineering Department of Chemical & Materials Engineering New Jersey Institute of Technology University Heights, Newark, NJ 07102 Tel: 973-596-3316; khusid@njit.edu
Paul Chaikin Co-PI / Provide flight samples, science requirements, and data analysis	Silver Professor; Professor of Physics Department of Physics New York University 726 Broadway, Room 877; New York, NY 10003 Tel: 212-998-7694; chaikin@nyu.edu
Andrew Hollingsworth Co-PI/ Provide flight samples, science requirements, and data analysis	Research Professor of Physics Department of Physics New York University 726 Broadway, Room 863B; New York, NY 10003 Tel: 212-998-8428; andrewdh@nyu.edu





MOTIVATION

- Like atoms forming molecules and crystals, colloidal particles are considered as blocks for building materials. While the scenario of manipulating one atom at a time proposed by Richard Feynman in 1959 still remains in its infancy, guided manipulation of colloidal particles has become a widespread means for manufacturing functional materials in electronics, photonics, life science, chemical industries, and recently in 3D printing.
- The rich variety of colloidal structures observed in terrestrial experiments could also have been influenced by gravity effects, such as particle sedimentation, convection and jamming. Microgravity offers a unique opportunity to study colloids without masking gravity effects.
- The research addresses fundamental and technological questions aimed at understanding the equilibrium and metastable crystalline, liquid, and glassy structures of colloids and their use in additive manufacturing.

Crystallization of hard-sphere colloids in microgravity

Jixiang Zhu*, Min Li†, R. Rogers‡, W. Meyer‡, R. H. Ottewill§, STS-73 Space Shuttle Crew||, W. B. Russel† & P. M. Chaikin*

NATURE | VOL 387 | 26 JUNE 1997



0.50 0.502 0.504 0.512 0.516 0.518 0.524 0.537



0.5470.549 0.561 0.591 0.605 0.618 0.615 0.633 0.634



Microgravity experiments by Chaikin's group in STS-83 and STS-94 missions reveals that gravity on Earth drastically changes the growth and coarsening of crystallites.



WHY MICROGRAVITY ON ISS?

➤ It is often assumed that time-average weightlessness simulated in a clinostat can reduce the effect of gravity on samples. Why not to use it for colloids?

➤ Low-gravity parabolic flight tests on a non-buoyancy matched suspension demonstrated that time-average weightlessness in a clinostat does not eliminate gravity effect on patterns in colloids formed by an electric field.

➤ The long-term microgravity ISS experiment provides a unique opportunity to reveal the relationship between external forces on the scale of individual particles and the colloid dynamics on the macroscopic scale.

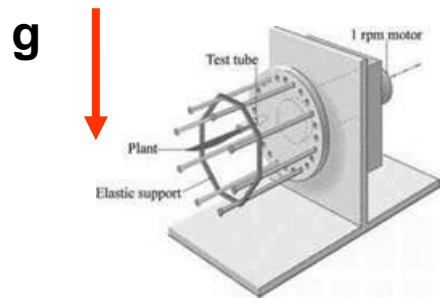

Clinostat uses slow rotation to negate the gravity effects on plants and cell cultures in biological experiments for centuries.

Effects of clinorotation and positive dielectrophoresis on suspensions of heavy particles

Nikolai Markarian, Mike Yeksel, and Boris Khusid
New Jersey Institute of Technology, University Heights, Newark, New Jersey 07102

Anil Kumar
The Levich Institute, The City College of New York, New York, New York 10031

Padetha Tin
National Center for Microgravity Research in Fluids and Combustion, NASA Glenn Research Center, Cleveland, Ohio 44135

Physics of Fluids 16, 2004

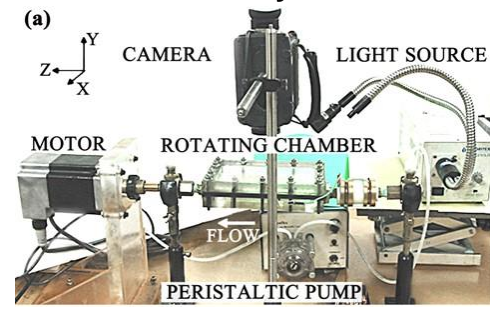

Clinostat in low and normal gravity

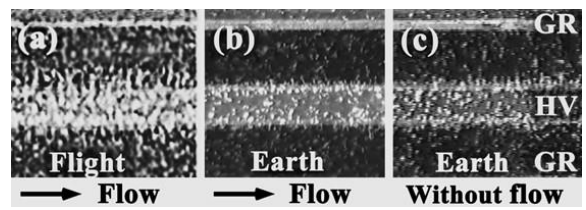



HYPOTHESIS

- A difference between MD simulation predictions for the crystal growth rate and experiments ~12 orders of magnitude!
- The contrast in structures formed in model suspensions under microgravity in ACE-T11 and normal gravity on Earth will reveal the salient features of the influence of a temperature gradient and gravity on non-equilibrium colloidal processes.
- Understanding these phenomena is essential for the development and operation of a wide range of terrestrial and space applications involving colloids.



INVESTIGATION GOALS AND OBJECTIVES

- An outstanding problem in condensed matter science concerns the non-equilibrium crystallization of metastable liquids. The major challenge is due to kinetic limitations as particles can be trapped into metastable configurations for a long time due to the lower mobility of multi-particle structures.
- The simplest colloid to study crystallization is naturally comprised of hard-sphere particles. ACE-T11 experiments will vary temperature gradients to explore the effect of thermophoresis on crystallization of hard-sphere colloids.
- The goal is to crystallize a hard-sphere metastable colloidal liquid and study the nucleation and growth of crystals simultaneously in different regions of the phase diagram of hard-sphere colloids.



Measurement approach – 1/15

We will be using a flight-hardened Commercial-Off-The-Shelf (COTS) microscope

[pictured on next page]

and an

ACE-T sample module

[pictured later]



Measurement approach – 2/15

Light Microscopy Module (LMM) in the Fluid Integrated Rack (FIR)

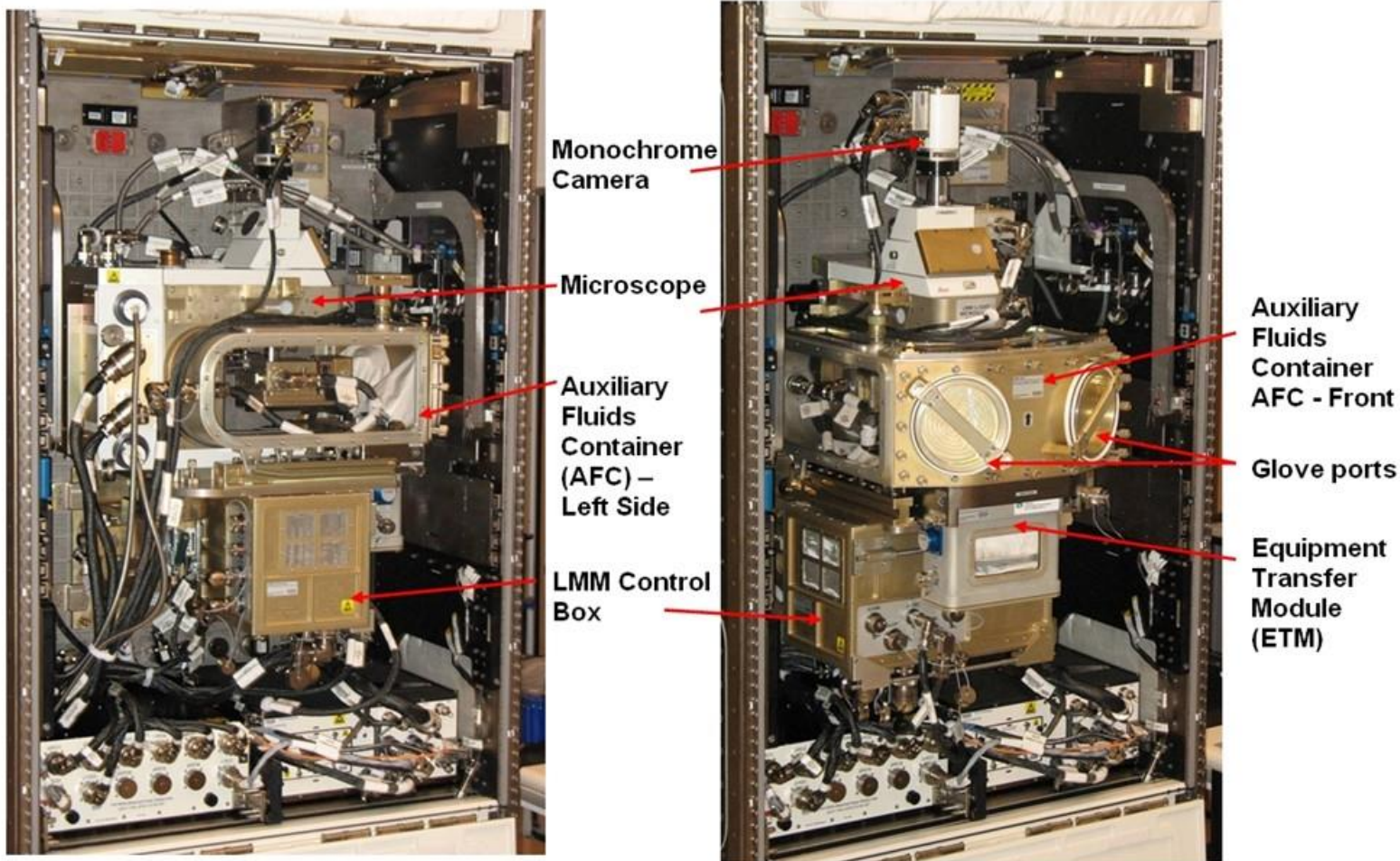

LMM in the Closed Position or Operating Configuration

LMM in the Open Position or Installation/Service Configuration



Measurement approach – 3/15



LMM Implementation Philosophy

Philosophy: Maximize the scientific results by utilizing the existing LMM capabilities. Develop small sample modules and image them within the LMM

Light Microscopy Module

Payload specific and multi-user hardware customizes the FIR in a unique laboratory configuration to perform research effectively.



FCF Fluids Integrated Rack

- Power Supply
- Avionics/Control
- Common Illumination
- PI Integration Optics Bench
- Imaging and Frame Capture
- Diagnostics
- Environmental Control
- Data Processing/Storage
- Light Containment
- Active Rack Isolation System (ARIS)

Multi-Use Payload Apparatus

Payload Specific Hardware

- Sample Cell with universal Sample Tray
- Specific Diagnostics
- Specific Imaging
- Fluid Containment

- Test Specific Module
- Infrastructure that uniquely meets the needs of PI experiments
- Unique Diagnostics
- Specialized Imaging
- Fluid Containment



Measurement approach – 4/15

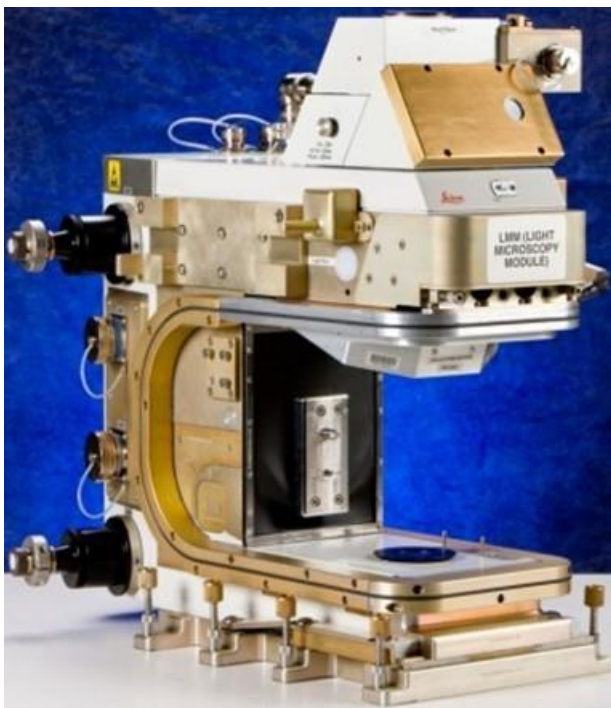

Light Microscopy Module (LMM)

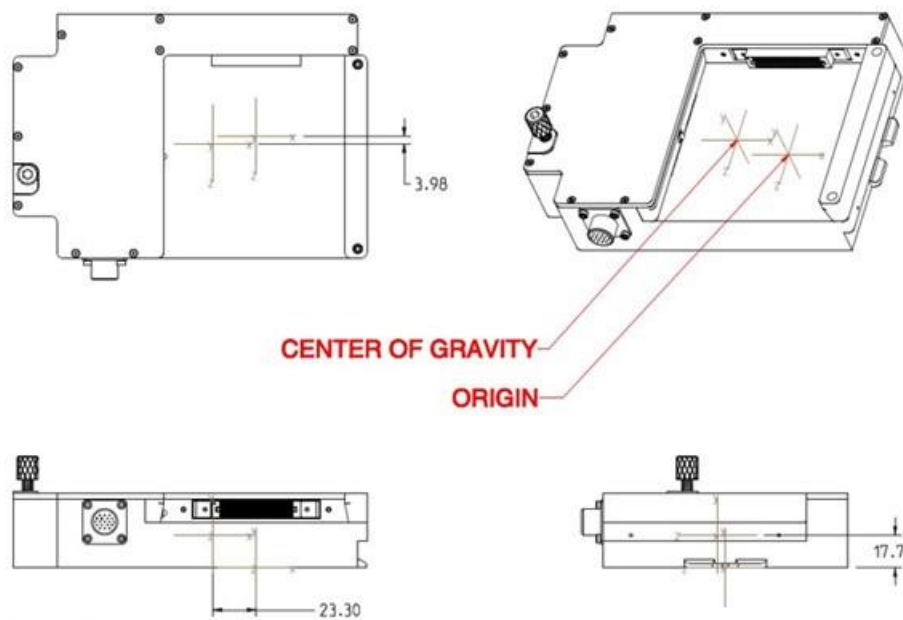
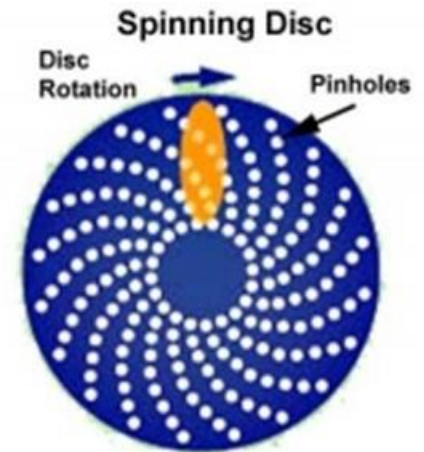
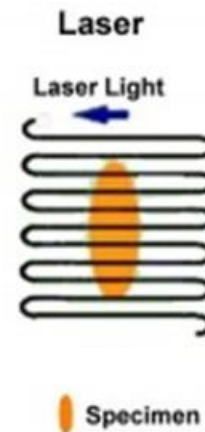
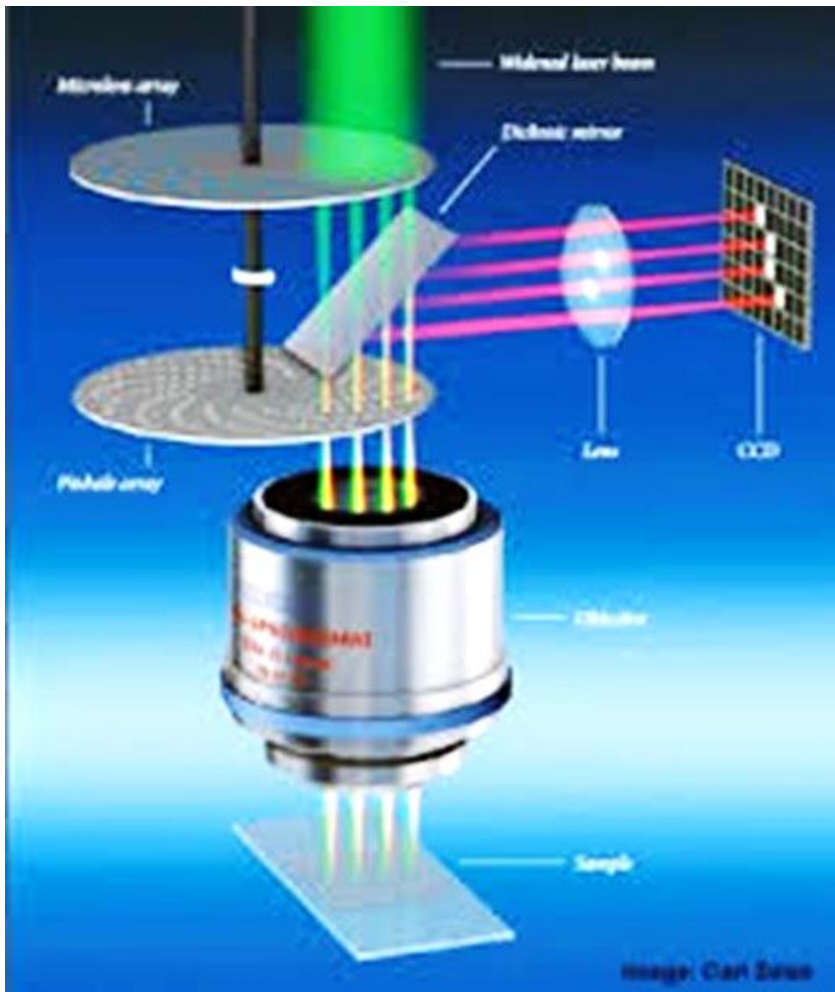

Figure 1: Center of Mass for ACE-T

ACE Sample Assembly with Removable ACE-T Sample Tray that will contain a row of 3 temperature controlled capillary cells



Measurement approach – 5/15





Measurement approach – 6/15

The difference between traditional and confocal microscopy

Focus 50 μm below cover slip

*Focus 200 μm below
(near bottom of well)*

*Traditional microscopy
doesn't see through
objects well; out-of-
focus light obscures
in-focus light*



**Particles on top are
easily imaged**



**Particles on bottom
are entirely obscured**

*Confocal microscopy
rejects out-of-focus
light, to look
through semi-
transparent objects*

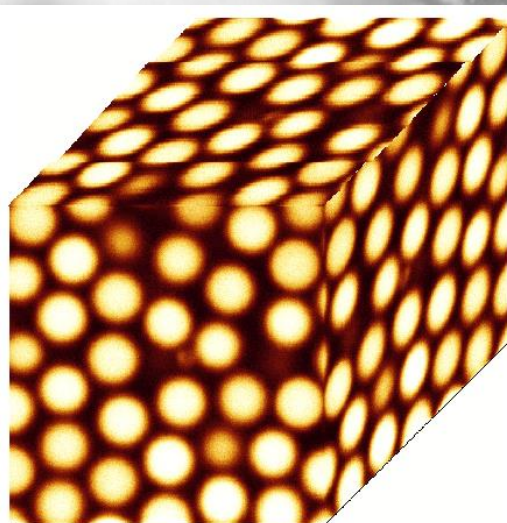

**3D image is built out of
2D XY sections while
stepping through Z axis.**



Measurement approach – 7/15

Mechanical Design Highlights

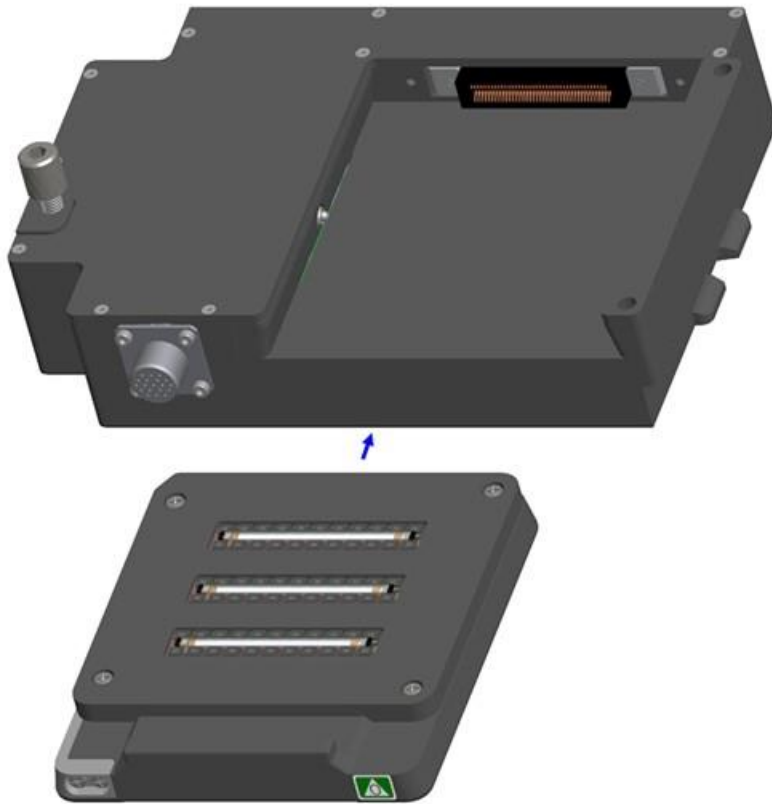

- Modular sample assemblies
 - Allows for multiple sample configurations.
 - Easier Sample replacement
 - Decreased “ACE-T” up-mass in comparison to ACE-H





Measurement approach – 8/15

Mechanical Design Highlights

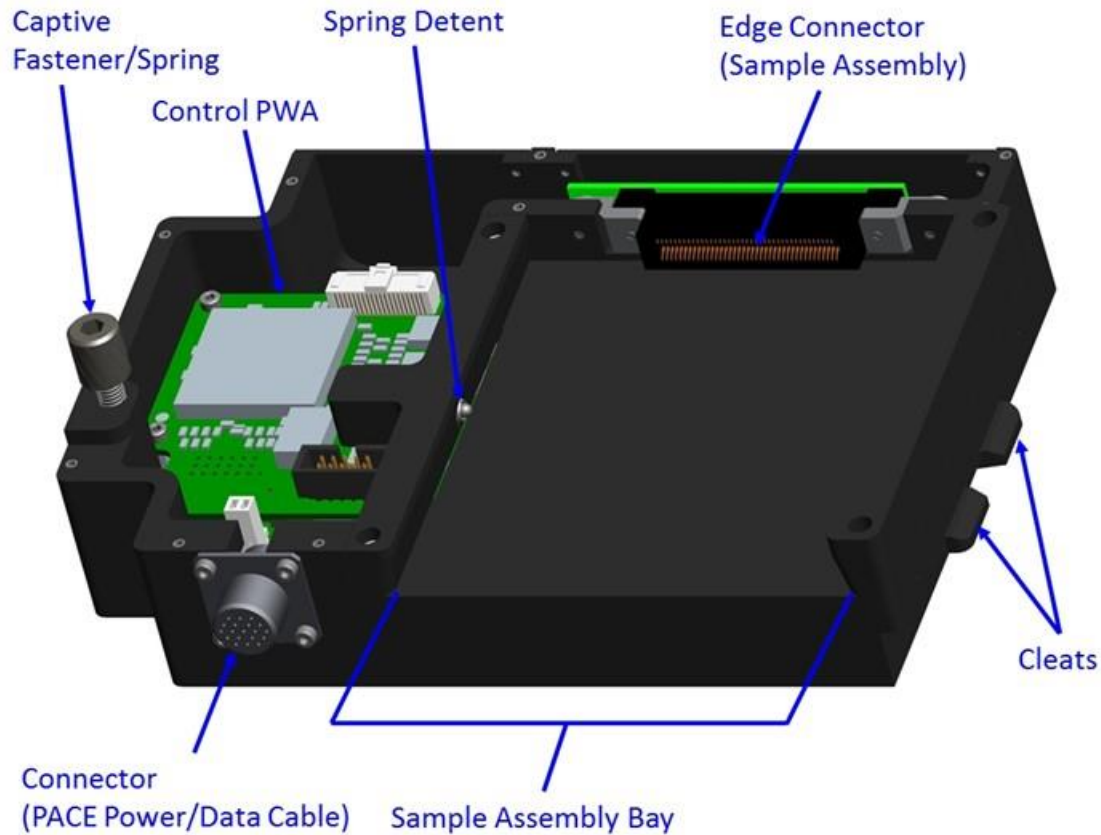



Measurement approach – 9/15

Mechanical Design Highlights

- In-situ mixing (details in electrical section)
- Black Hard Anodize Surface Coat
 - Reduction of any errant light within the AFC
 - Increased wear resistance

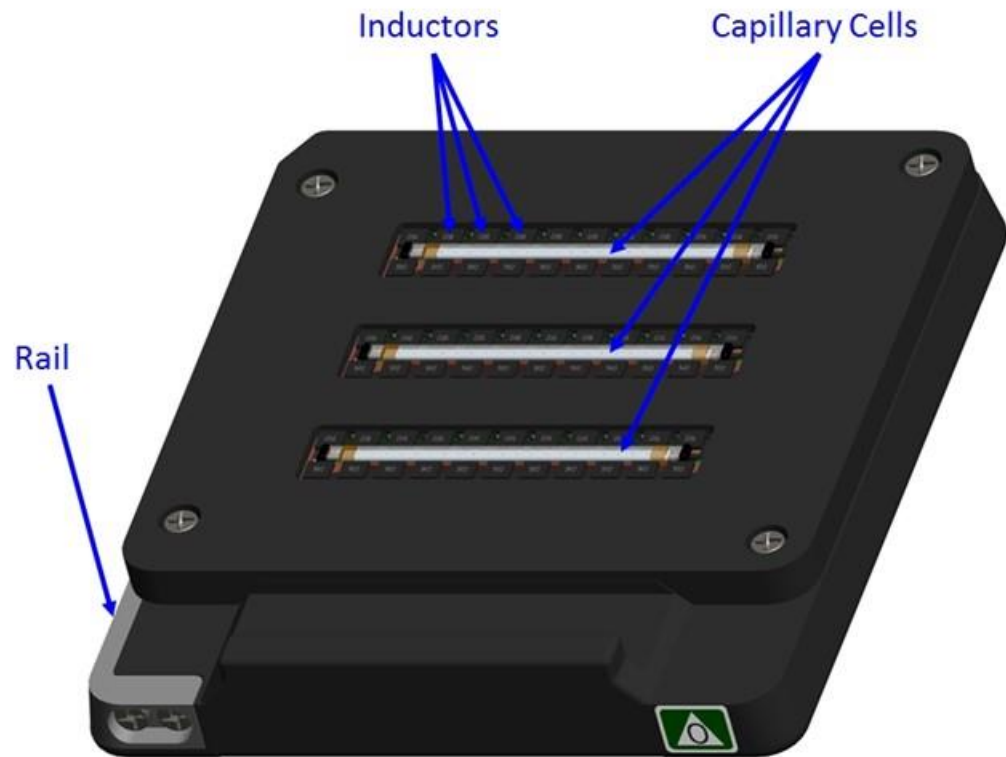



Measurement approach – 10/15

Mechanical Design Highlights

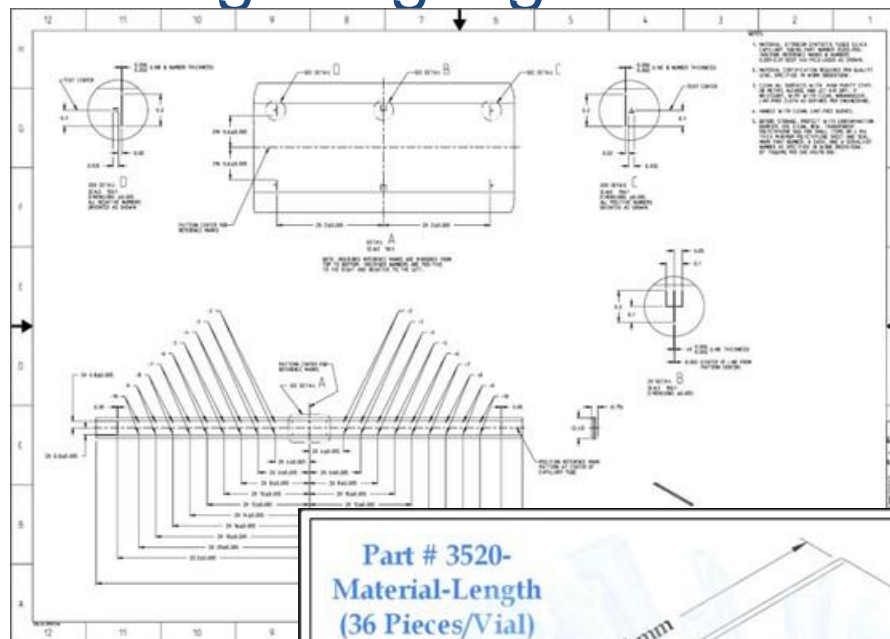

**Part # 3520-
Material-Length
(36 Pieces/Vial)**

TOLERANCES	LENGTH (mm)
ID +/- 10 %	50 + 2 / - 0 300 + 10 / - 0
Wall +/- 20 %	100 + 4 / - 0 600 + 20 / - 0

**VITROCOM
TECHNICAL GLASS**

Capillary cell

- Purchased through VitroCom.com
- Material
 - Borosilicate (3520-050)
 - Fused Silica by request (3520S-050)
- COTS
- 50mm length
- Reference Marks
 - Secondary Process to ease positional awareness

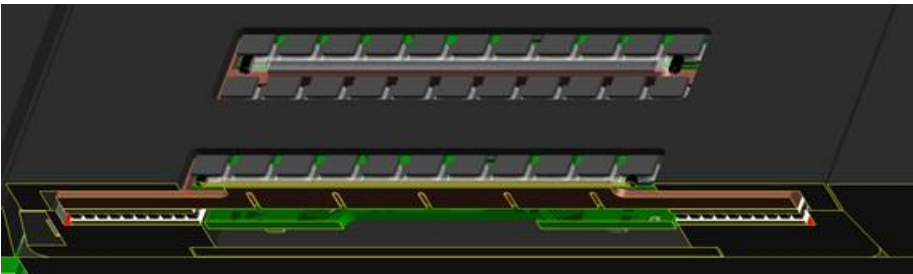

Two capillary cells surrounded by inductors that are used for walking a turning stir-bar for sample mixing.



Measurement approach – 11/15

Temperature gradient

- Thermal bridge
- Material: Copper
- Bridges thermal energy between TEM's
- Constrains Thermistor Positioning
- Thermal symmetry across X and Y Axes*
 - *When set-points are equal

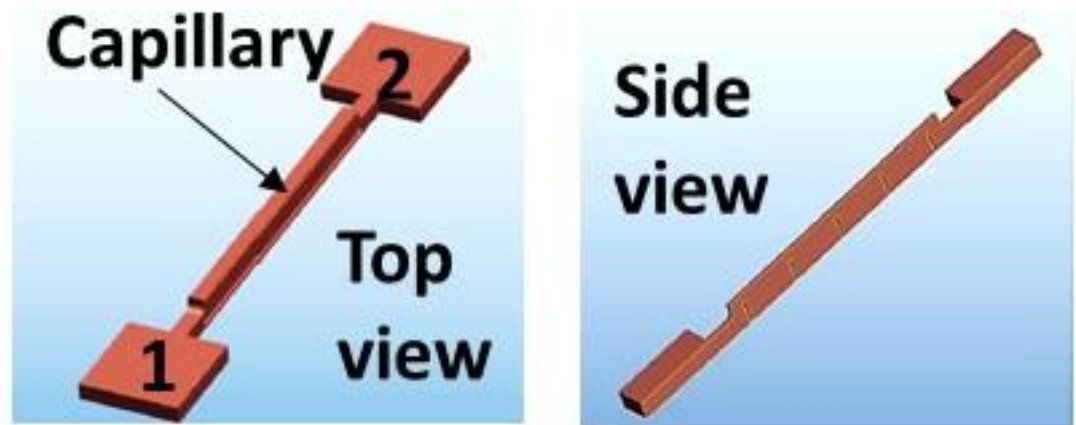

ACE-T will enable temperature control that can either be linear across the capillary - or a temperature gradient across the capillary. A temperature gradient will form a gradient of the concentration of colloidal particles due to thermophoresis.



Measurement approach – 12/15

Operational Requirements [nasa.gov]: Defines constraints and requirements necessary to complete the investigation (number of subjects or observations, spacing of observations, downlink of data, return of samples, etc.).

- Two experiment modules, each containing three capillary cells, are desirable. The first will be loaded with samples 1-3 and the other with samples 4-6. Every experiment module is expected to run several times for testing repeatability. A microscopic observation on one capillary at a fixed temperature difference between the capillary ends is expected to require 1–7 days (the actual duration will depend upon the number of z-scans that are needed to evaluate the particle velocity and the dynamics of colloidal structuring).
- Each capillary will be tested at two different temperature gradients formed by keeping the capillary ends at different temperatures, one at $\Delta T = 10^\circ\text{C}$ and the other at $\Delta T = 20^\circ\text{C}$. A potential thermal bias will be estimated by conducting experiments at every ΔT by applying the temperature gradient from left to right, then from right to left and then at the uniform temperature equal to the average of left capillary end temperature T_L and the right capillary end temperature T_R .
- Operational protocol is the same for each experiment. Inspect each capillary for air bubbles using a low magnification objective. Switch observation area or capillary if air bubbles exceed allowable size.
- Use balance of experiment time, *i.e.*, the rest of the week, to analyze data, re-write scripts, adjust parameters, *etc.* Observation position repeatability: the need to return to the same Region of Interest (ROI), *i.e.*, colloidal structures – or to maintain *XYZ* coordinates during an experiment – implies maintaining one capillary position. If this requirement takes an excessive amount of time, find a solution. For example, images can be registered in post-processing via port or stir bar location, or pattern of particles stuck to bottom of cover slip.



Measurement approach – 13/15

Operational Requirements [nasa.gov]: Defines constraints and requirements necessary to complete the investigation (number of subjects or observations, spacing of observations, downlink of data, return of samples, etc.).

Capillary #	Experiment #	Left end temperature T_L , °C	Right end temperature T_R , °C	Requirement
1	1	20	30	Complete upon evaluation by PI.
1	2	30	20	Complete upon evaluation by PI.
1	3	25	25	Complete upon evaluation by PI.
2	4	20	30	Complete upon evaluation by PI.
2	5	30	20	Complete upon evaluation by PI.
2	6	25	25	Complete upon evaluation by PI.
3	7	20	30	Complete upon evaluation by PI.
3	8	30	20	Complete upon evaluation by PI.
3	9	25	25	Complete upon evaluation by PI.

The imaging goal is to observe (1) real-time and three-dimensional particle centroid positions in colloidal structures and over both short (30 minutes) and long period (up to one week); (2) assembled structures under thermophoresis and to resolve particle centroid positions. For short-time imaging, the video should be taken with 5 fps over 30 minutes. For both cases, the x-y positions of particles should be determined with less than 5% error (with respect to particle diameter). The z-positions should be determined within 1 micron. For fluorescence imaging, lamp should be shuttered between image sets to prevent sample bleaching.



Measurement approach – 14/15

Operational Requirements [nasa.gov]: Defines constraints and requirements necessary to complete the investigation (number of subjects or observations, spacing of observations, downlink of data, return of samples, etc.).

Capillary #	Experiment #	Left end temperature T_L , °C	Right end temperature T_R , °C	Requirement
1	1	20	40	Complete upon evaluation by PI.
1	2	40	20	Complete upon evaluation by PI.
1	3	30	30	Complete upon evaluation by PI.
2	4	20	40	Complete upon evaluation by PI.
2	5	40	20	Complete upon evaluation by PI.
2	6	30	30	Complete upon evaluation by PI.
3	7	20	40	Complete upon evaluation by PI.
3	8	40	20	Complete upon evaluation by PI.
3	9	30	30	Complete upon evaluation by PI.

The imaging goal is to observe (1) real-time and three-dimensional particle centroid positions in colloidal structures and over both short (30 minutes) and long period (up to one week); (2) assembled structures under thermophoresis and to resolve particle centroid positions. For short-time imaging, the video should be taken with 5 fps over 30 minutes. For both cases, the x-y positions of particles should be determined with less than 5% error (with respect to particle diameter). The z-positions should be determined within 1 micron. For fluorescence imaging, lamp should be shuttered between image sets to prevent sample bleaching.



Measurement approach – 15/15

Operational Protocols [nasa.gov]: Descriptive overview of the investigation on orbit procedures.

General experiment steps on each capillary for imaging of colloidal structuring at a specified temperature difference between the capillary left end T_L and right T_R end:

1. Inspect the samples.
2. Mix the sample in sample module using the in-situ mixer for 1 minute(s).
3. Define XY offsets.
4. Experiment on one capillary using the 100x oil (or 63x air) objective. The use of high numeric aperture (oil immersion) lenses requires the control of the objective temperature because the immersion oil will be thermally coupled with the cell capillary and affect its temperature. Therefore, 63x air objective is preferable.
5. Adjust camera parameters using 2.5x objective and bright field.
6. Survey capillary(s) at 2.5x, scanning in the X direction over a range of at least 10 millimeters. Determine bubble locations and possible primary (and secondary) Regions of Interest (ROI). If the 2.5x objective is difficult to switch in and out with the 63x air or 100x oil objective, then find ROI capillary cells before using 63x air or 100x oil objective. Select primary locations away from stir bar or bubble. There will be about (9) 800 x 800 micron areas within the capillary strip. The number of areas may increase once usage of the flight capillary cell design is available to test.
7. Set the specified temperature T_L (ramp rate $1^\circ\text{C}/\text{min}$) for left end of the capillary and T_R for the right end. Using 63x air objective or 100x oil objective, observe the motion of particles in the field of view.
8. Focus on the inner surface of the bottom glass capillary, it is closest to the objective.
9. Take one image at each of the z -depth and scan over the thickness of the glass capillary (e.g., twenty z -depths over 100 microns). The z -scanning rate should be set as fast as possible, potentially 5 -10 frames per second. No pixel binning, 8 bits per pixel (highest supported), full frame images. The number (e.g., 20 here) of z -depths depends on the lengths of colloidal structures and the thickness of glass capillary.
10. Repeat the z -scan of the same colloidal structure over 30 minutes.
11. Find another colloidal structure by moving the stage in x - y direction.
12. Repeat steps 8-11.
13. To obtain statistically meaningful data, at least ten colloidal structures in one capillary should be imaged. This calculates to at least ~400 minutes for one capillary.
14. Complete upon evaluation by PI.



ACE-T11 CONCEPT

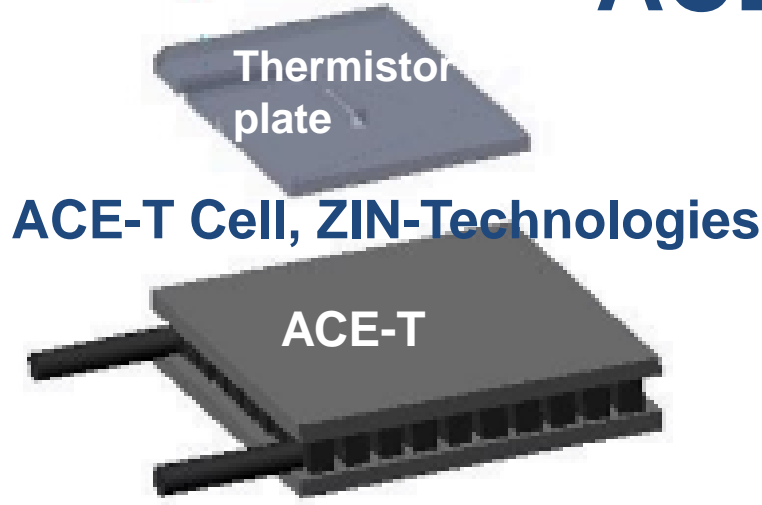

Osmotic pressure $\Pi = (k_B T / v_p) \phi Z(\phi)$

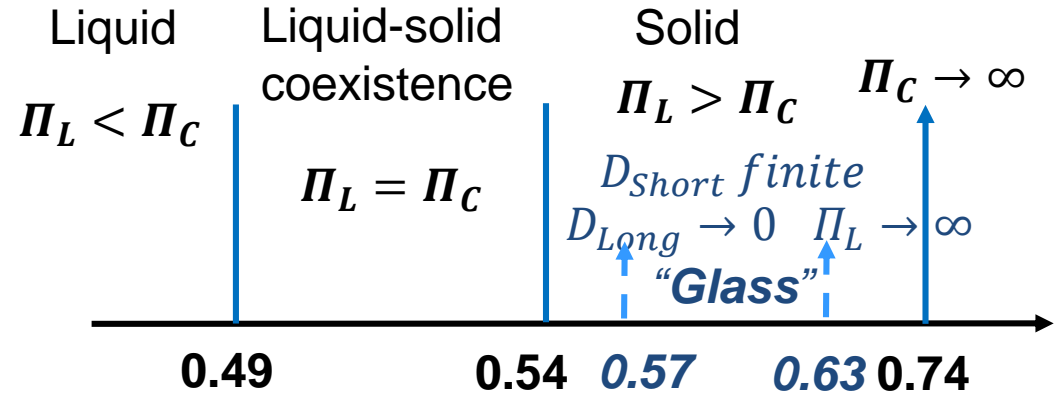

Osmotic pressure scale $\frac{k_B T}{v_p} \sim 0.002 Pa$

Particle long-time and short-time self-diffusivity

$$D_L = D_0 (1 - \phi / \phi_g)^{m_L}$$

$\phi_g \sim 0.58$ $m_L \sim 2.6$

$$D_s = D_0 (1 - \phi / \phi_c)^{m_s}$$

$\phi_c \sim 0.74$ $m_s \sim 1.6$

Thermophoresis is the translational motion of a colloidal particle caused by a non-uniform thermal field with the velocity proportional to the temperature gradient.

- Two week crystal growth ~ 1-2 mm
- Specimens in both regions of phase diagram.

Osmotic pressure $\Pi = const$

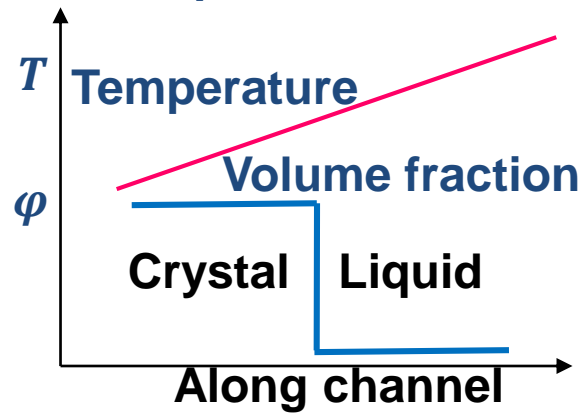



ACE-T11 SAMPLES

Thermophoresis will dominate when mechanical equilibrium is established across the capillary

$$\Pi = \text{const}$$

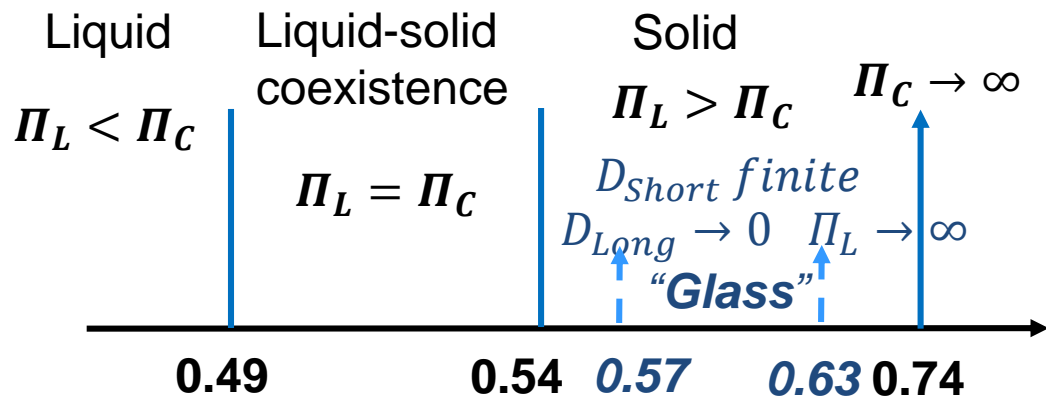

Sample #	Particle %	Polydispersity, %	Hot end	Cold end
1	49	Less 5	Liquid	Solid
2	52	Less 5	Liquid /solid	Glass
3	55	Less 5	Solid	Glass
4	49	10-20	Liquid	Solid
5	52	10-20	Liquid /solid	Glass
6	55	10-20	Solid	Glass



Experiments on Earth

Controlled growth of hard-sphere colloidal crystals

Zhengdong Cheng*, William B. Russel† & P. M. Chaikin*

NATURE | VOL 401 | 28 OCTOBER 1999

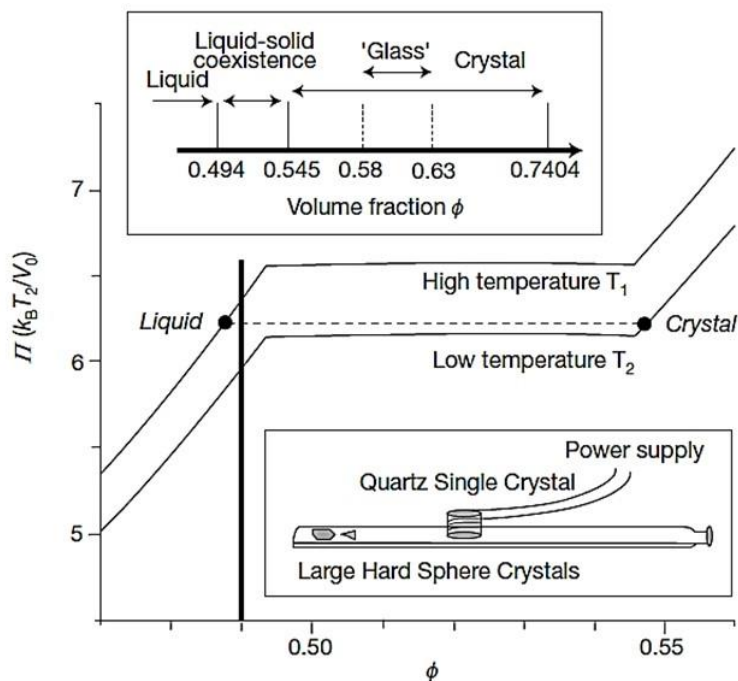

Equilibrium phase diagram of hard sphere suspension (top) and experimental setup

Observed colloidal structures could have been influenced by gravity effects, such as particle sedimentation, convection and jamming.

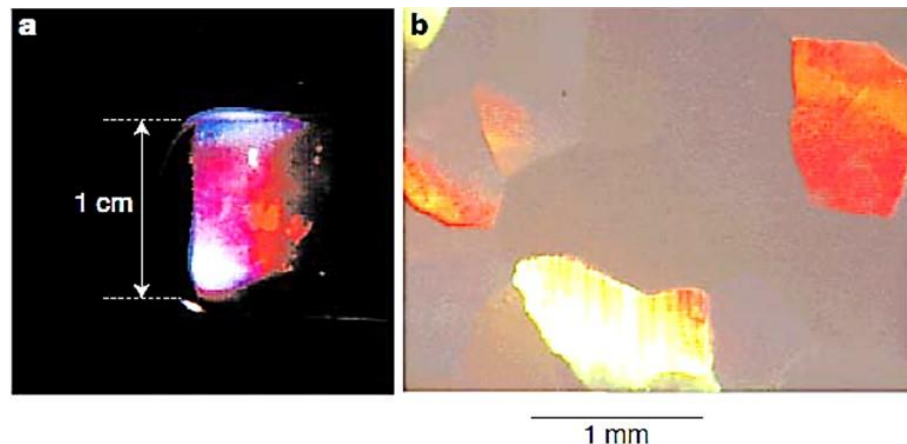

(a) a photo of colloidal crystals formed at the cold end of the sample, (b) a micrograph showing the crystal morphology.



It's sedimentary
my Dear Watson

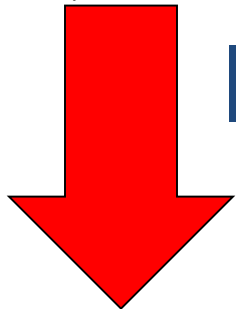

IMPORTANCE AND REASON FOR ISS

- In ACE-T11, the crystallization of micron-sized colloidal particles is studied in a non-uniform thermal field.
- In the microgravity, we hope to observe crystalline structures that are impossible to create on Earth due to sedimentation issues (high density contrast between particles and fluid).

A temperature gradient will form a gradient of colloidal particle concentration! You can now march through a phase diagram using a single capillary and have a common error bar for all measurements.

Hard Sphere Equilibrium Phase Diagram

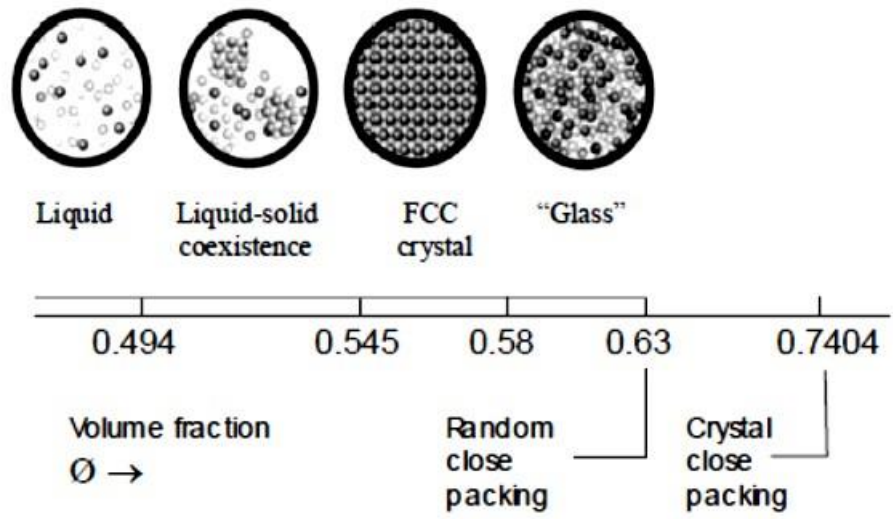



EXPECTED RESULTS AND HOW THEY WILL ADVANCE THE FIELD

Detection of a Dynamic Cone-Shaped Meniscus on the Surface of Fluids in Electric Fields

Ezinwa O. Elele,¹ Yueyang Shen,¹ Donald R. Pettit,² and Boris Khusid^{1,*}
¹New Jersey Institute of Technology, Newark, New Jersey 07102, USA
²NASA Johnson Space Center, Houston, Texas 77058, USA
Phys Rev Lett 114, 054501 (2015)

- Due to masking gravity effects, numerous terrestrial studies conducted so far have not clarified subtle interplay of macroscopic and microscopic processes in colloids at particle level.
- Based on our previous findings, we expect that the contrast in guided assembly of colloidal structures in microgravity and on Earth should reveal the coupling between the gradient driven macroscopic transport of particles to predetermined locations and the microstructure they form there.
- Understanding the underlying mechanisms will open pathways for engineering novel functional materials across a broad range of terrestrial and space applications.

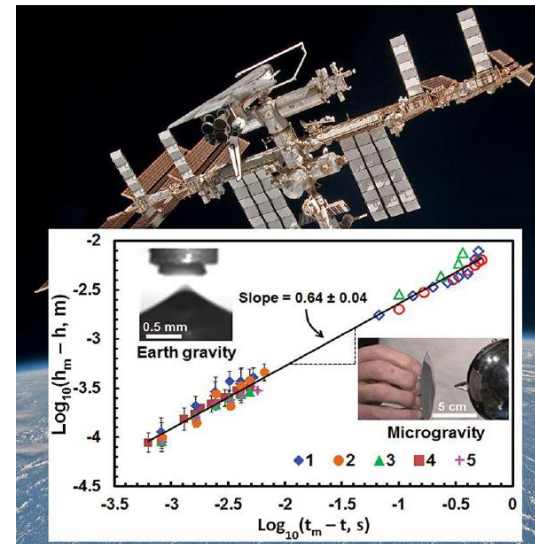

A cone-shaped meniscus of electrified fluids (Taylor cone) is observed in rain drops and lightning and employed in numerous applications

Spanning more than two orders of magnitude in length and time, data on microliter droplets on Earth and on milliliter droplets in ISS revealed that cusp evolution exhibits a universal self-similarity insensitive to the forcing electric field and droplet size!



A contrast between microgravity and terrestrial experiments provides unique advantages to reveal hidden features of multiphase systems since their behavior is inevitably influenced by gravity effects:

- Fundamental studies of Order, Frustration:
The role of macroscopic and microscopic forces in structure formation.
- Technologies for complex processes including 3D printing:
Pathway for fabrication of multiphase micro-structured heterogeneous items from polymers, metals and ceramics.



EARTH BENEFITS / SPIN-OFF APPLICATIONS

photonic crystals

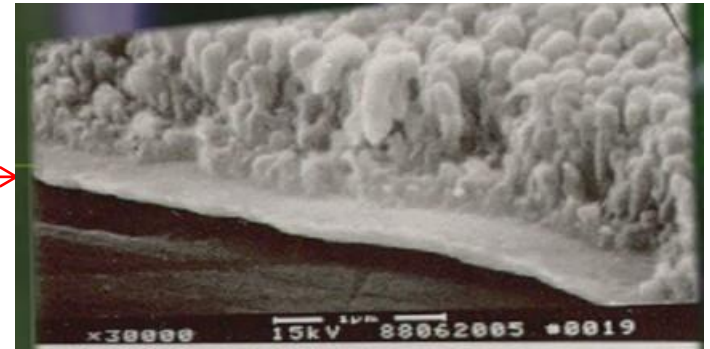

- The proposed research will scrutinize the colloid behavior for inquiring about the nature of metastable structures formed by external field gradients in the absence of gravity at a particle level.
- Although the time and equipment available for microgravity tests is limited, research outcomes have a potential to develop foundations for guided assembly of colloidal structures with hierarchical organization from the nanometer and micrometer length scales to macroscopic dimensions for diverse applications in science and technology, ranging from optics and photonics to bioscience and biotechnologies and to electromagnetic and acoustic metamaterials.



ACE-T11

Increment 59/60 Science Symposium

BACKUP SLIDES





Advanced Colloids Experiment (Temperature controlled) – ACE-T11

ACE-T11 PI Flight Endorsement Letter





Samples 1/6

Capillary #	Capillary Cell Contents			
NJIT & NYU ACE-T11 Flight Sample #1 (P/N: T11_Flt_Sample1)	Suspending media:	composition , wt %	particle polydispersity, wt%	comments
	C/T decahydronaphthaline	20.70		refractive index matching
	1,2,3,4-tetrahydronaphthaline	25.30		
	Particles:			
	colloid: poly(methyl methacrylate-co-methacrylic acid) (PMMA) spheres	49.0	<i>less 5</i>	1 to 2 microns
	fluorophore (rhodamine B, or julolidine rhodol, or Cy3)	< 0.01		fluorophore chemically attached to PMMA
	poly(12-hydroxystearic acid)-g-poly(methylmethacrylate) (PHS-g-PMMA) surfactant	< 0.1		chemically attached to particle surface
	depletant: silica nanoparticles	5.0		100 nm diameter
	trimethoxysilyl-terminated PHS-g-PMMA surfactant	< 0.1		chemically attached to particles
TOTAL	100.0			



Samples 2/6

Capillary #	Capillary Cell Contents			
NJIT & NYU ACE-T11 Flight Sample #2 (P/N: T11_Flt_Sample2)	Suspending media:	composition , wt %	particle polydispersity, wt%	comments
	C/T decahydronaphthaline	19.35		refractive index matching
	1,2,3,4-tetrahydronaphthaline	23.65		
	Particles:			
	colloid: poly(methyl methacrylate-co-methacrylic acid) (PMMA) spheres	52.0	<i>less 5</i>	1 to 2 microns
	fluorophore (rhodamine B, or julolidine rhodol, or Cy3)	< 0.01		fluorophore chemically attached to PMMA
	poly(12-hydroxystearic acid)-g-poly(methylmethacrylate) (PHS-g-PMMA) surfactant	< 0.1		chemically attached to particle surface
	depletant: silica nanoparticles	5.0		100 nm diameter
	trimethoxysilyl-terminated PHS-g-PMMA surfactant	< 0.1		chemically attached to particles
TOTAL	100.0			



Samples 3/6

Capillary #	Capillary Cell Contents			
NJIT & NYU ACE-T11 Flight Sample #3 (P/N: T11_Flt_Sample3)	Suspending media:	composition , wt %	particle polydispersity, wt%	comments
	C/T decahydronaphthaline	18.00		refractive index matching
	1,2,3,4-tetrahydronaphthaline	22.00		
	Particles:			
	colloid: poly(methyl methacrylate-co-methacrylic acid) (PMMA) spheres	55.0	<i>less 5</i>	1 to 2 microns
	fluorophore (rhodamine B, or julolidine rhodol, or Cy3)	< 0.01		fluorophore chemically attached to PMMA
	poly(12-hydroxystearic acid)-g-poly(methylmethacrylate) (PHS-g-PMMA) surfactant	< 0.1		chemically attached to particle surface
	depletant: silica nanoparticles	5.0		100 nm diameter
	trimethoxysilyl-terminated PHS-g-PMMA surfactant	< 0.1		chemically attached to particles
	TOTAL	100.0		

From C.O.C. date June 19, 2017



Samples 4/6

Capillary #	Capillary Cell Contents			
NJIT & NYU ACE-T11 Flight Sample #4 (P/N: T11_Flt_Sample4)	Suspending media:	composition , wt %	particle polydispersity, wt%	comments
	C/T decahydronaphthaline	20.70		refractive index matching
	1,2,3,4-tetrahydronaphthaline	25.30		
	Particles:			
	colloid: poly(methyl methacrylate-co-methacrylic acid) (PMMA) spheres	49.0	10 – 20	1 to 2 microns
	fluorophore (rhodamine B, or julolidine rhodol, or Cy3)	< 0.01		fluorophore chemically attached to PMMA
	poly(12-hydroxystearic acid)-g-poly(methylmethacrylate) (PHS-g-PMMA) surfactant	< 0.1		chemically attached to particle surface
	depletant: silica nanoparticles	5.0		100 nm diameter
	trimethoxysilyl-terminated PHS-g-PMMA surfactant	< 0.1		chemically attached to particles
	TOTAL	100.0		



Samples 5/6

Capillary #	Capillary Cell Contents			
NJIT & NYU ACE-T11 Flight Sample #5 (P/N: T11_Flt_Sample5)	Suspending media:	composition , wt %	particle polydispersity, wt%	comments
	C/T decahydronaphthaline	19.35		refractive index matching
	1,2,3,4-tetrahydronaphthaline	23.65		
	Particles:			
	colloid: poly(methyl methacrylate-co-methacrylic acid) (PMMA) spheres	52.0	10 – 20	1 to 2 microns
	fluorophore (rhodamine B, or julolidine rhodol, or Cy3)	< 0.01		fluorophore chemically attached to PMMA
	poly(12-hydroxystearic acid)-g-poly(methylmethacrylate) (PHS-g-PMMA) surfactant	< 0.1		chemically attached to particle surface
	depletant: silica nanoparticles	5.0		100 nm diameter
	trimethoxysilyl-terminated PHS-g-PMMA surfactant	< 0.1		chemically attached to particles
	TOTAL	100.0		



Samples 6/6

Capillary #	Capillary Cell Contents			
NJIT & NYU ACE-T11 Flight Sample #6 (P/N: T11_Flt_Sample3)	Suspending media:	composition , wt %	particle polydispersity, wt%	comments
	C/T decahydronaphthaline	18.00		refractive index matching
	1,2,3,4-tetrahydronaphthaline	22.00		
	Particles:			
	colloid: poly(methyl methacrylate-co-methacrylic acid) (PMMA) spheres	55.0	10 – 20	1 to 2 microns
	fluorophore (rhodamine B, or julolidine rhodol, or Cy3)	< 0.01		fluorophore chemically attached to PMMA
	poly(12-hydroxystearic acid)-g-poly(methylmethacrylate) (PHS-g-PMMA) surfactant	< 0.1		chemically attached to particle surface
	depletant: silica nanoparticles	5.0		100 nm diameter
	trimethoxysilyl-terminated PHS-g-PMMA surfactant	< 0.1		chemically attached to particles
	TOTAL	100.0		

From C.O.C. date June 19, 2017



ACE-T11 Success Criteria



Complete success is the achievement of all of the science requirements. This means that there will be sufficient information to provide a crosscheck of all data and calculated factors. Processing, manipulation and characterization of the samples in micro-gravity are as important as the measurements during the experiments themselves. e.g., sample homogenization is essential to conduct of any of the flight experiments. This allows for the homogenization of the crystallites or any structures formed from phase separation or gelation that have occurred in 1g before launch, and provides a proper starting point in micro-g.

Success Level	Accomplishment
Minimum Success	<ul style="list-style-type: none">• Homogenize completely at least 40% of the complete set of samples, and observe the time evolution with (using pre-confocal - bright field and fluorescent microscopy; and if available and working we would use confocal microscopy for appropriate samples) imaging for several days to weeks, depending on rates of changes caused by the application of a temperature gradient that will be determined in real-time as data is downlinked to earth (these cannot be predicted accurately ahead of time in the 1g environment).• Have sufficient data (both in terms of frequency and duration) from microscopy of sufficient quality to observe, characterize and quantify the rates of growth of structures formed as a result of the physical process of interest in microgravity, including but not limited to crystallization, phase separation and gelation. The behavior cannot be predicted ahead of time, often new mechanisms can be observed whose presence is masked on earth by the presence of gravity.• We hope that these processes will generate new structures formed by thermophoresis in microgravity, that may direct further earthbound studies and inspire new directions for materials synthesis and fundamental physics understanding.
Significant Success	<ul style="list-style-type: none">• Accomplish the above for 50% of the different types fluid samples launched.
Complete Success	<ul style="list-style-type: none">• Accomplish the above for all launched samples, with multiple runs to repeat the experiment and assess reproducibility.



Microgravity Justification

- Formation of colloidal structures is profoundly affected by gravity via sedimentation processes. Chaikin and Russel have already demonstrated this effect in space experiments exploring the simplest of all entropic transitions, the hard-sphere liquid-solid phase transition.
- Sedimentation causes particles to fall so rapidly that there is insufficient time for particles to explore the full phase space of positions and velocities that are required for thermodynamic assembly processes. A substantial particle concentration gradient arises in the earthbound sample.

$$h = \frac{kT}{\Delta\rho V g}$$

h = gravitational height

kT = Thermal Energy of system

$\Delta\rho$ is the density difference between the particles and the background fluid

V is the particle volume

g is the gravitational acceleration

h ranges from a few microns for the case of polystyrene in water to a fraction of a micron for most of the other particles we consider. Our particles are usually of order 1 micron in diameter.



Microgravity Justification

(continued)

- In addition, the shear forces of fluid flow due to the sedimenting particles is often sufficient to break structures that are forming thermodynamically.
- The solvents we plan to use are restricted by various factors, for example by our need to fix the colloidal structures in space. Almost all of the particles of future interest are either too heavy or too light compared to water.
- Sample equilibration often requires ~1 to 12 hours. Structure growth sometimes continues for one to two more weeks after the initiation process. These processes are too slow for a drop tower or an airplane.
- Space station provides a unique environment where microgravity is sustained long enough to allow these experiments to be conducted. The samples can be homogenized, and then allowed to develop via thermophoresis in the microgravity environment. Their structures and optical properties can be measured. For most samples we are contemplating, the density mismatch between particle and background fluid is large (e.g. $> 1.1 \times$). Microgravity dramatically reduces these differences and permits true equilibrium processes to occur.

END