



The Kilopower Space Nuclear Fission Power Reactor

Max Chaiken

Kilopower Project

NASA Glenn Research Center

Interagency Advanced Power Group

Mechanical Working Group

May 16th, 2019

Johnson Space Center, Houston, Texas



Kilopower Introduction



- **Momentum**
 - 2018 Kilopower Reactor Using Stirling Technology (KRUSTY) demonstration was a successful nuclear hardware demonstration
 - Renewed interested in space fission power applications
- **Opportunity**
 - Kilopower project team has been tasked with formulating a Technology Demonstration Mission (TDM) flight program
 - Qualify nuclear fission power systems for lunar surface applications in support of the Lunar Surface Innovation Initiative
- **Sound Engineering**
 - Key decisions regarding power conversion sizing and implementation remain
 - Qualifying for the additional radiation environment of the fission reactor
- **Responsible Policy**
 - Nuclear fission materials require added layers of security
 - Ensuring a safe launch and operation is the highest priority

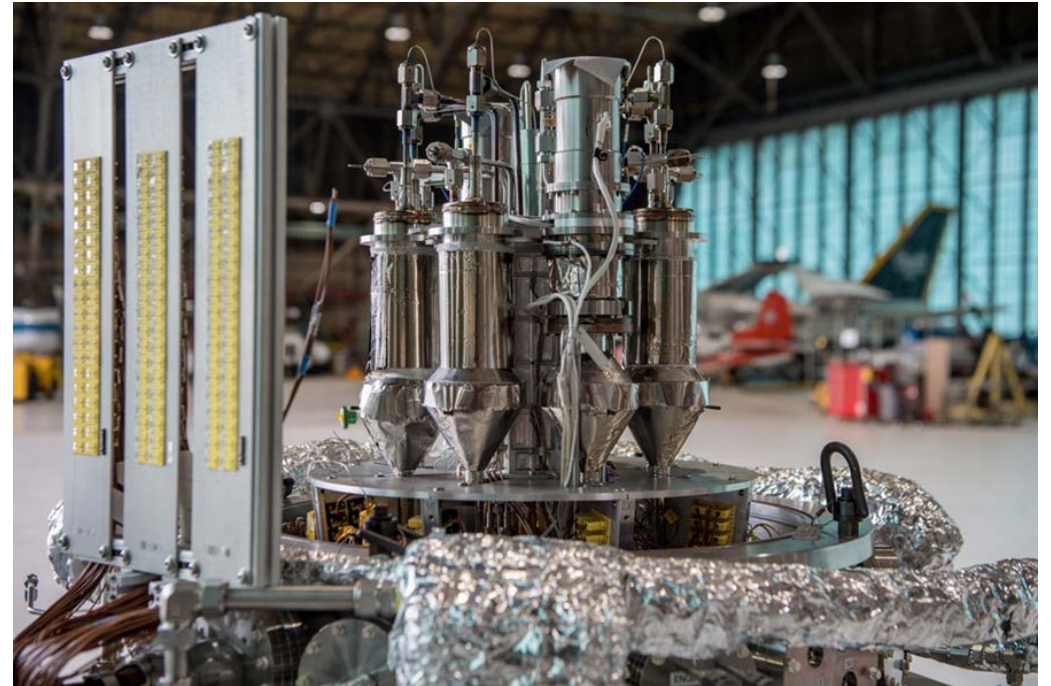



Agenda



- **KRUSTY Test Recap**
- **Kilopower TDM Formulation**
- **Engineering Tasks**
 - Engine Sizing
 - Heat Pipe to Engine Interface
 - Radiation Testing
- **Policy Tasks**
 - Launch Safety Considerations

Motivation for KRUSTY Test



- **Goal**
 - Provide compact, low cost, scalable modular power system
 - Address needs for human exploration or science missions providing 1 to 10 kWe
- **Cost Effective Implementation**
 - Maximize existing technologies & materials
 - Key team members with ready expertise on small team
 - Utilize existing facilities such as DOE Nevada National Security Site (NNS)
- **Innovation**
 - Novel integration of available U235 fuel, passive sodium heat pipes, and commercially-derived Stirling power conversion
 - Provides solution up to 10 kWe stand-alone system, or in redundant & fault tolerate multi-unit architecture for HEOMD Surface Missions for ISRU and/or crew ops.
- **Extensibility**
 - Alternative for Science nuclear missions that rely on RPS using scarce Pu238
 - Increase available power from 100s of watts to 1 kW or higher using Kilopower

Kilopower Reactor Using Stirling Technology



- Collaboration between NASA and DoE
 - GRC, MSFC
 - LANL, Y12, NNSS
- Test performed at the Nevada National Security Site
 - In the Device Assembly Facility (DAF)
 - Using existing criticality control hardware (COMET test stand)
- Maintained budget and schedule
 - 3 1/2 year development
 - \$20M including cost share with DoE
- First space nuclear hardware test in >50 years
 - SNAP-10A: Flown 1965
 - SP-100: Designed 1983-1995, no nuclear testing
 - Prometheus: Designed 2003-2005, no nuclear testing
- First new fission reactor design fully tested in 40 Years



KRUSTY System Components



- The KRUSTY test was designed to represent as many significant flight subsystems as possible
- Flight prototypic
 - Core
 - Reflector
 - Heat pipe material and fluid
 - Stirling engine heat conversion
- Missing
 - Startup using Boron Carbide control rod
 - Radiation shielding
 - Microgravity heat pipe operation
 - Optimized engine sizing
 - Heat rejection radiators
 - Radiation tolerant electronics and controllers

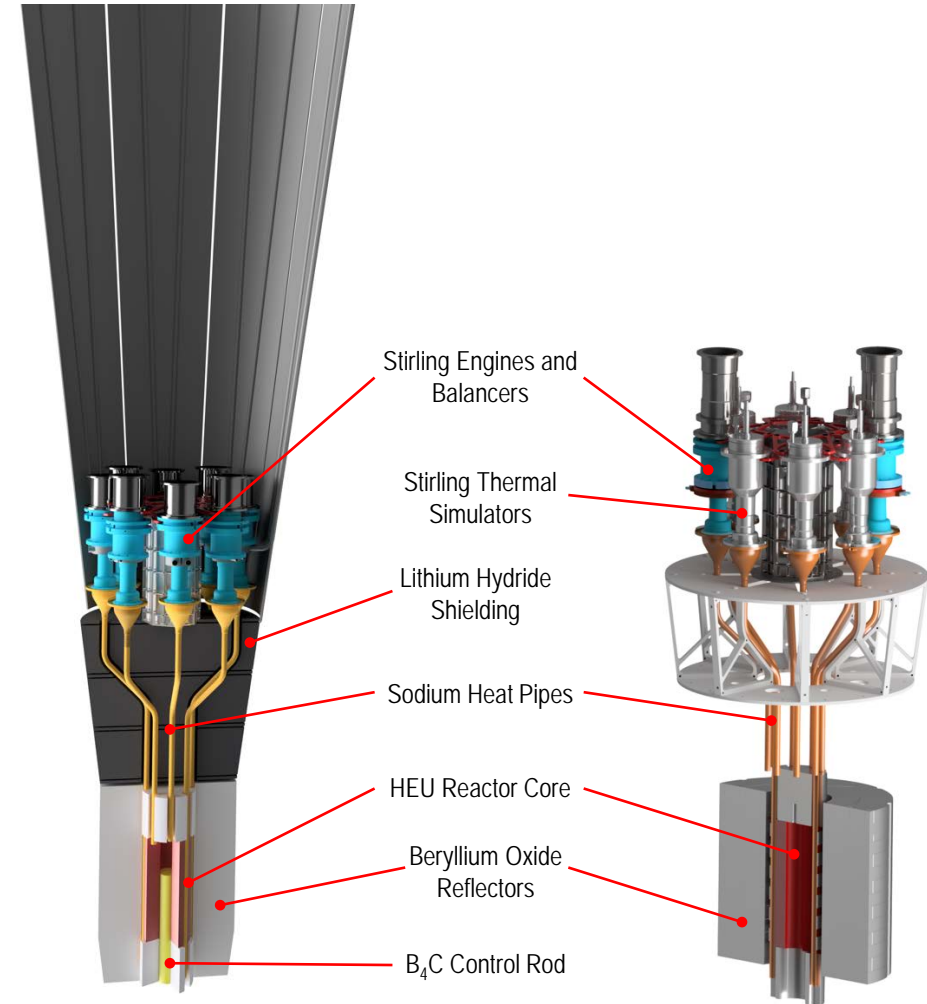

Reactor Assembly

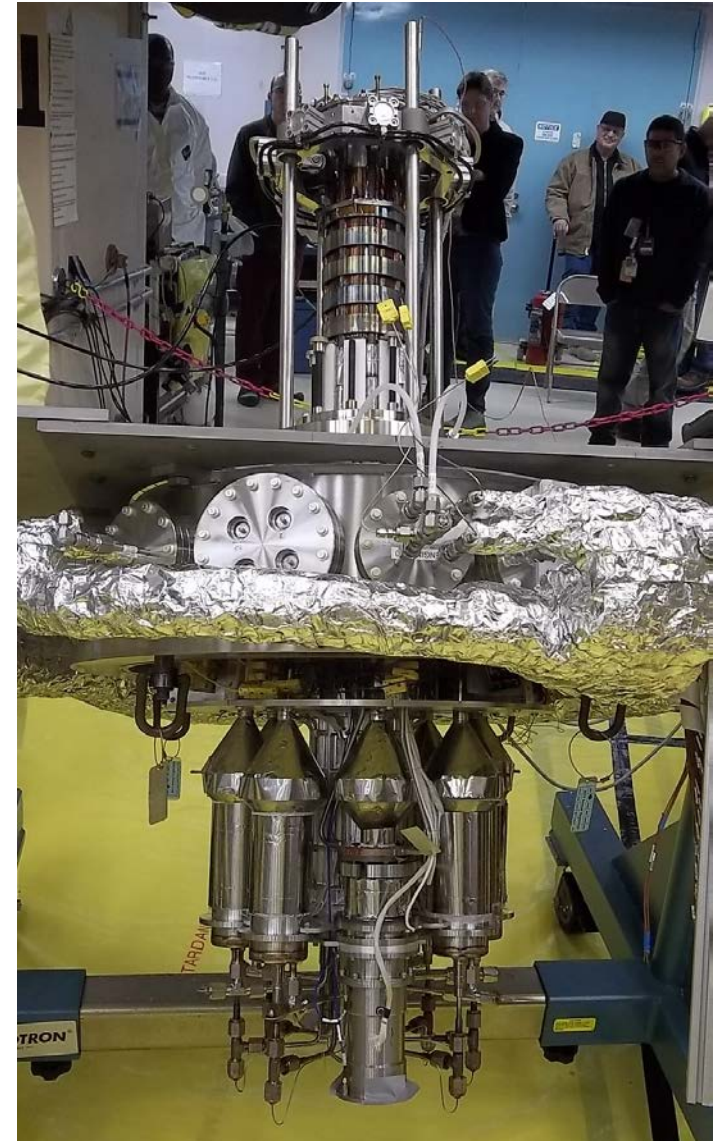

Experiment Assembly





Full Test Data



- Operated for ~28 hours
- Nominal steady state
- Off-nominal responses
- Fission rate measured by neutron counters positioned around the experiment
- Fission rate does not provide a 1-to-1 correlation with nuclear power produced

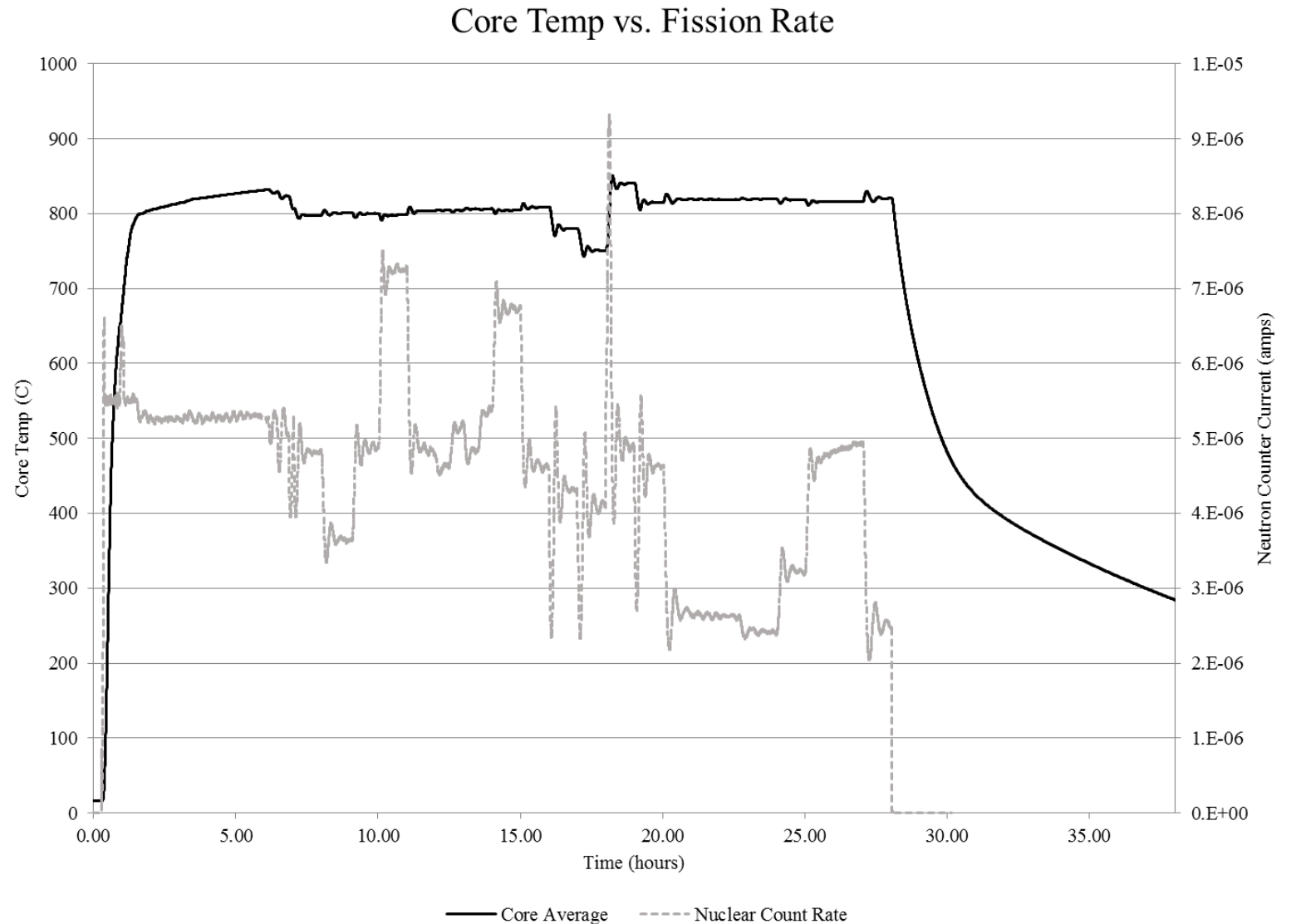



Key Test Activities



- Startup
- Break-in
- Power Transients
- Nuclear Transients
- Loss of Coolant Test
- Engine Restart
- SCRAM and Cooldown

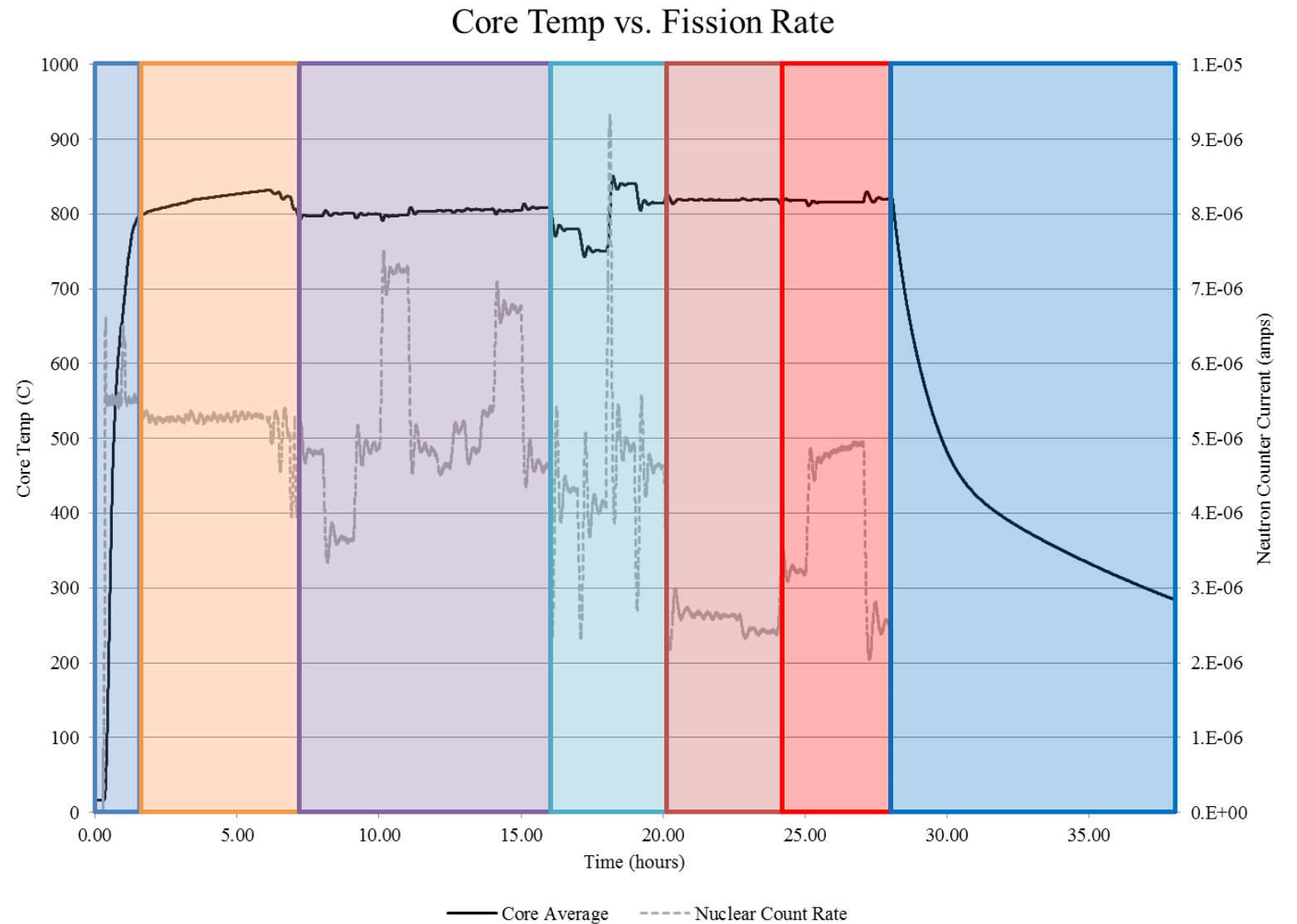



Nuclear Physics-Based Load Following



- Fission rate passively follows power loading
- Limits need for active control, increases system robustness

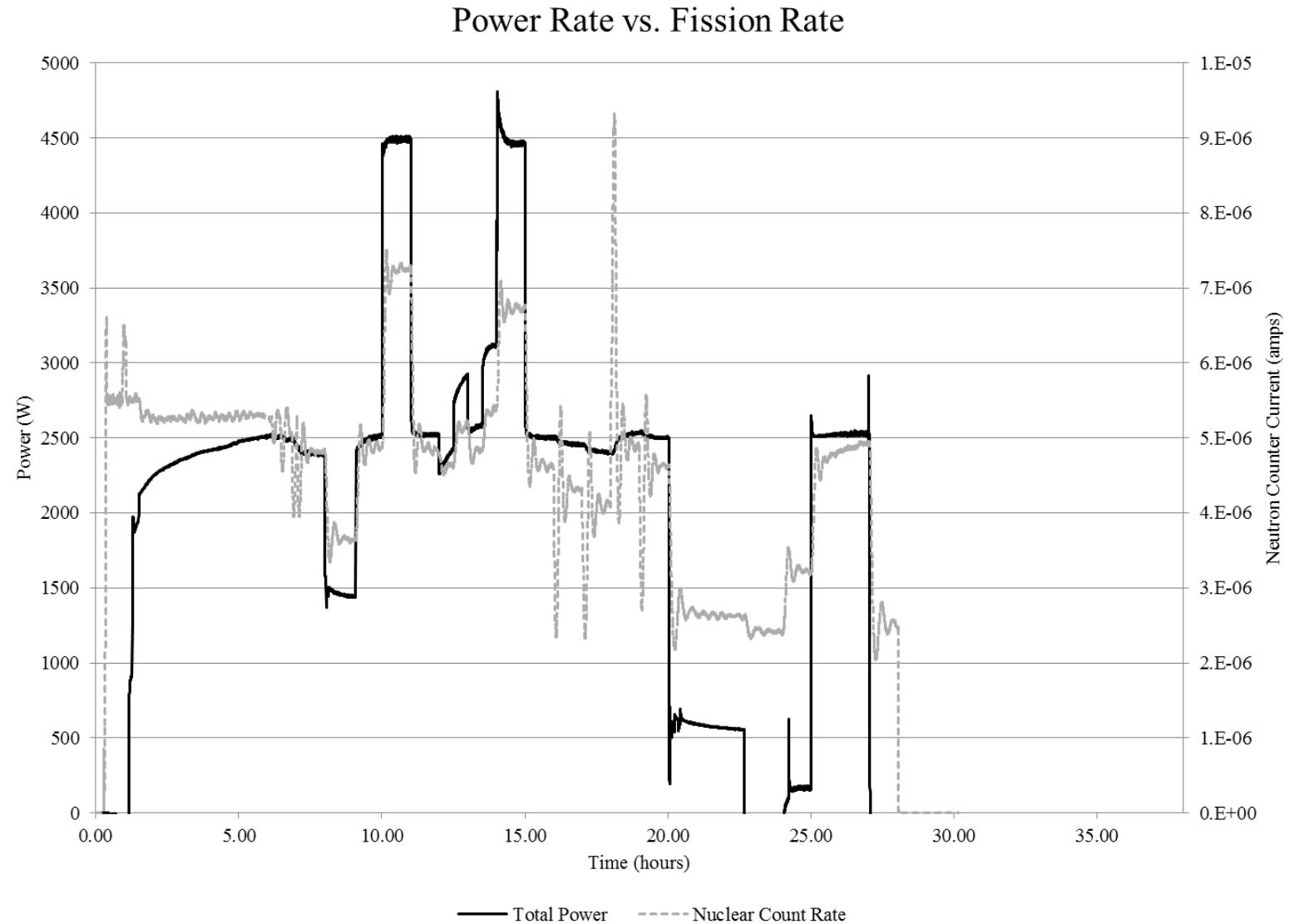



Constant Temperature Variable Power Source



- Core temperature does not significantly change during power transients
- Power can remain constant when core temperature changes

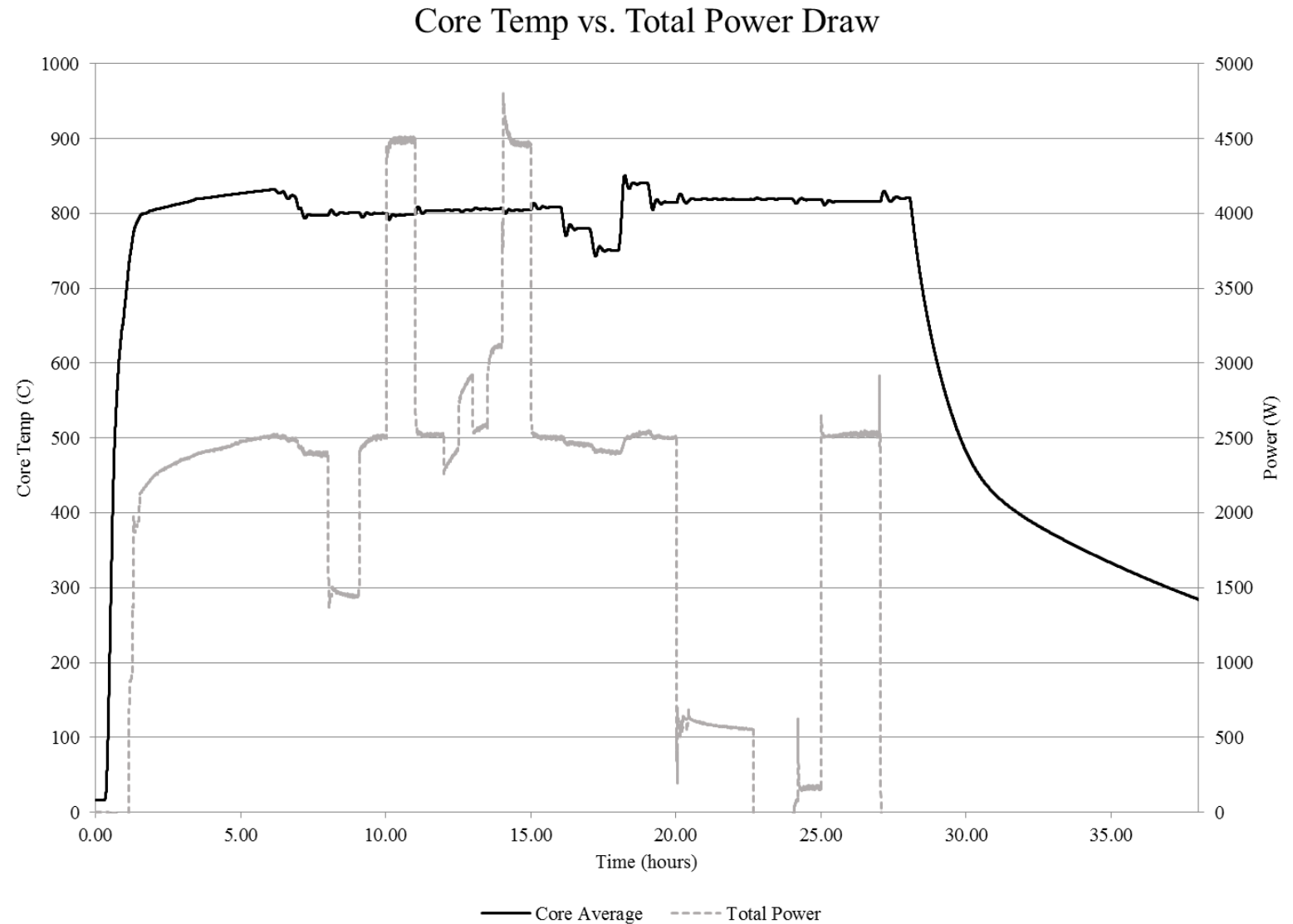

Technology Demonstration Mission Formulation



From the NASA FY2020
Budget Proposal

The Lunar Surface Innovation Initiative activities will be implemented through a combination of in-house activities, competitive programs, and public-private partnerships. The Initiative will bring together the full range of stakeholders, including entrepreneurs, academia, small businesses, industry and the NASA workforce to catalyze technology development. For example, this Initiative will develop and integrate systems used for in situ resource utilization and processing into mission consumables, including oxygen, water, and hydrogen. This capability will reduce mission mass, cost, and risk of human exploration, and increase independence from the Earth's resources. *NASA's Kilopower technology will transition into a demonstration mission - building on the 2018 demonstration of a small, lightweight nuclear fission power system that would permit long-duration crewed missions on the surface of the Moon.* Furthermore, the Initiative will jumpstart fuel cell development, space weather monitoring, and improve systems and components to allow survival and operation through the cold lunar night.

https://www.nasa.gov/sites/default/files/atoms/files/fy_2020_congressional_justification.pdf

Notional Mission

- 1 kW system power leveraging existing KRUSTY design
- Lunar surface destination with emphasis on providing power through the lunar night

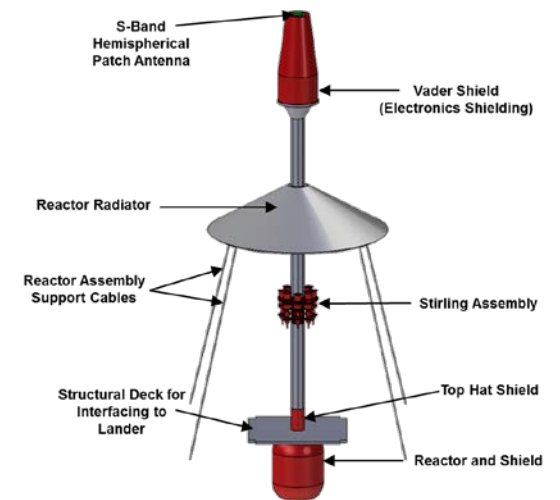
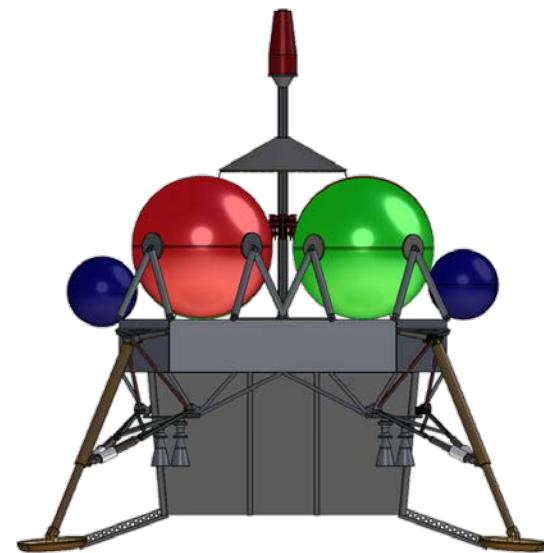

Flight Demonstration Checklist

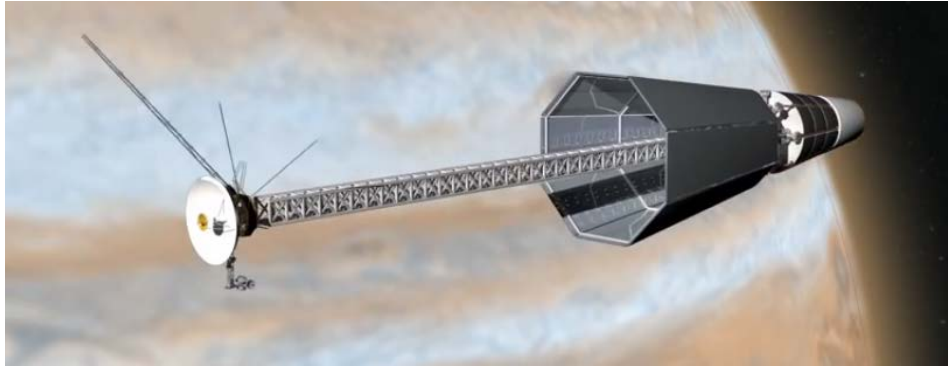

- Stirling Converters Power Sizing
- High Enriched Uranium (HEU) vs Low Enriched Uranium (LEU)
- Assembly, Test, and Launch Operations (ATLO)
- Control Architecture Reliability and Launch Safety
- Lunar Lander Interface
- Lunar Lander Site

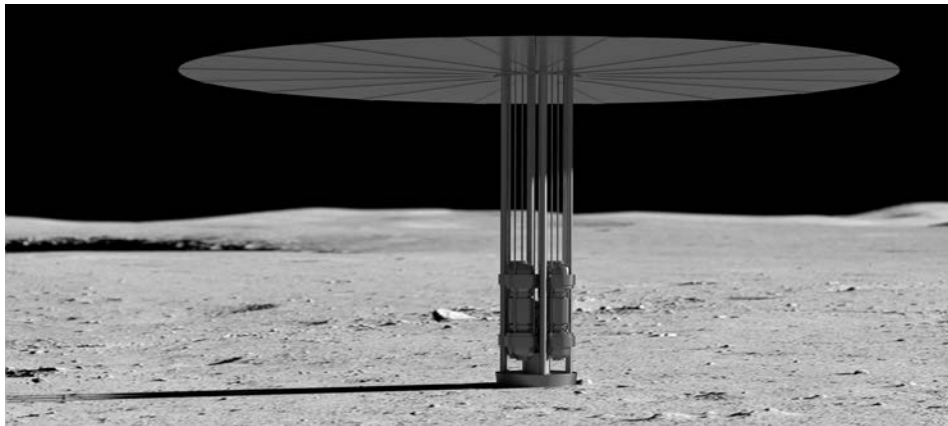

Higher Power Stirling Engines



- **Stirling engines used for KRUSTY test were from the Advance Stirling Radioisotope Generator (ASRG) program**
 - Nominally 80 W electrical power output, not optimal for Kilopower
 - Interface to heat source optimized for Pu-238 General Purpose Heat Source (GPHS)
 - ASRG was a flight program, system components have flight development heritage
- **Higher power engines are desired to increase system reliability**
 - Tentative target of 8x 250 W converters to provide 100% power redundancy for a 1 kW mission
 - >1 kW terrestrial Stirling engines exist, no breakthrough technology needed
 - Engine development requires prototyping, engineering set, qualification set, and flight sets - significant schedule and cost risk

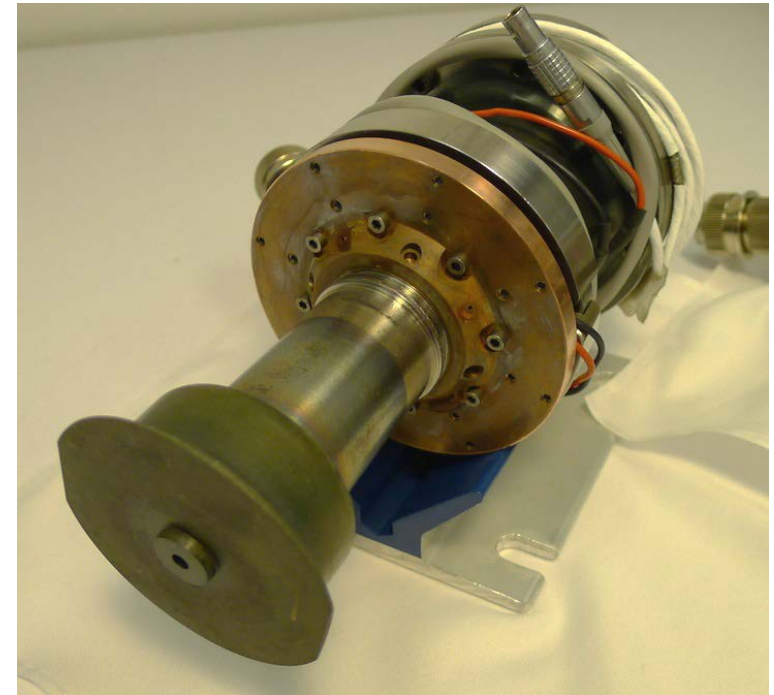



Heat Pipe to Stirling Engine Interface



- Redesign ASRG/GPHS interface
- Imbed engine heat acceptor inside the condenser space of the heat pipes
- Significant thermal performance improvement expected



Stirling Engine Interface Thermal Comparison at Constant Temperature

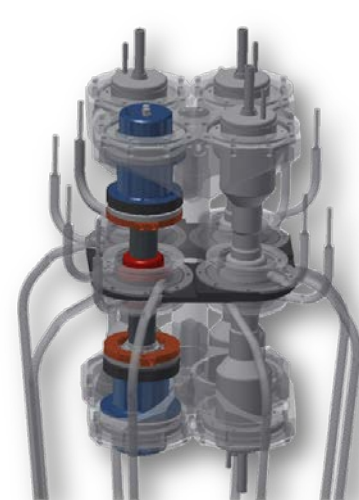
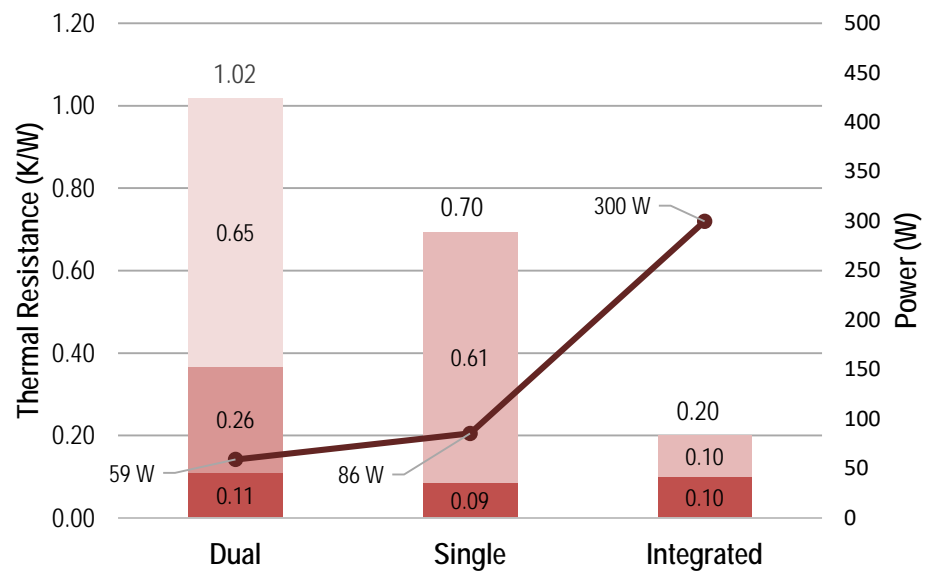

Dual Opposed

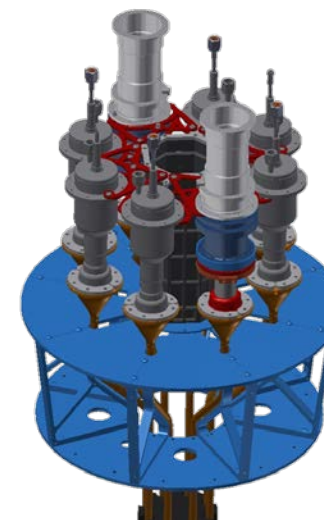

Single Engine

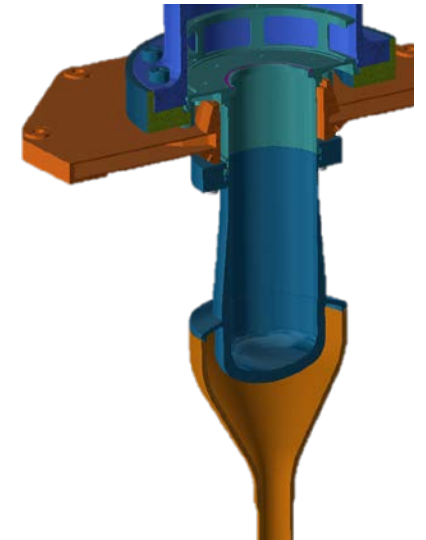

Integrated

- **Electronics Drive Radiation Shielding**
 - Shadow shield for in-space missions
 - Tomb shield for surface or crewed missions
 - Shield makes up 20 – 50% total system mass
 - Power and payload electronics drive shield mass for uncrewed missions
- **State-of-the-Art Radiation Tolerance**
 - Significant body of work on space radiation tolerance
 - Nuclear reactor radiation environment understood, but mostly un-tested
 - Modern electronics with 300 kRad(Si) Total Ionizing Dose (gamma of x-ray) tolerance
 - Possibly components with >1 MRad(Si) tolerance
 - Displacement damage for neutrons not well documented for state-of-the-art aerospace electronics

Shield Mass vs. Separation Distance and Tolerance Level for a 4 kWt Kilopower Reactor

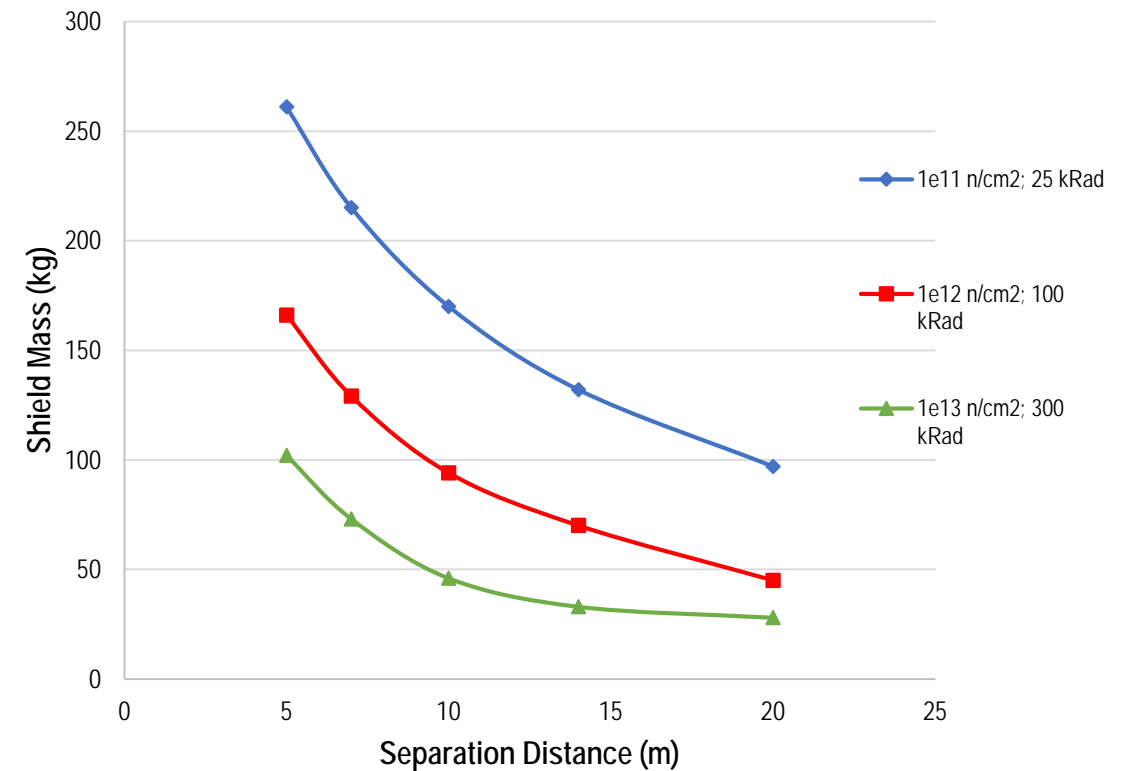

- **Materials near core subjected to fluence several orders of magnitude higher than electronics**
- **Two major areas of material tolerance concern**
 - Haynes 230 nickel alloy heat pipe material
 - Lithium Hydride radiation shielding option
- **Two facilities are being considered**
 - Texas A&M University Nuclear Science Center
 - ❖ 1 MW research reactor
 - ❖ 1.4×10^{13} n/cm²/s maximum flux
 - University of Missouri Research Reactor (MURR)
 - ❖ 10 MW research reactor
 - ❖ 24/7 operation
 - ❖ 6×10^{14} n/cm²/s maximum flux



HEU vs LEU



- LEU systems have more mass than HEU systems
- LEU core design requires in-core heat pipes, moving away from the KRUSTY design heritage
- Mass penalty as a percentage of total system mass decreases with increasing system power level
- Using LEU relaxes some of the security requirements, but material handling and transportation requirements remain
- Non-proliferation and good-stewardship should be considered

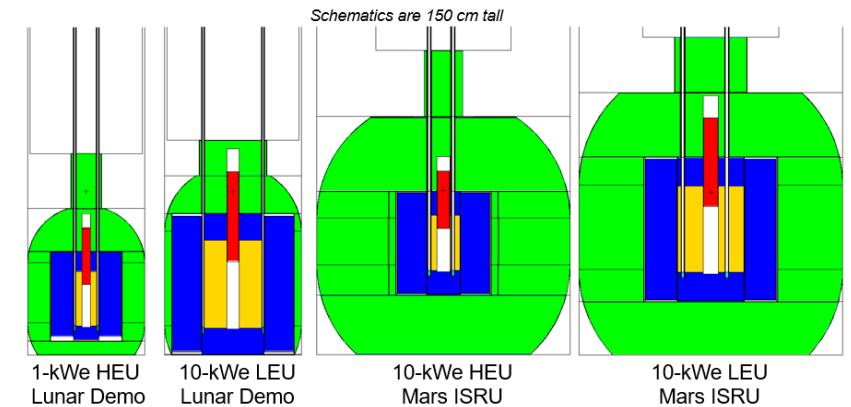
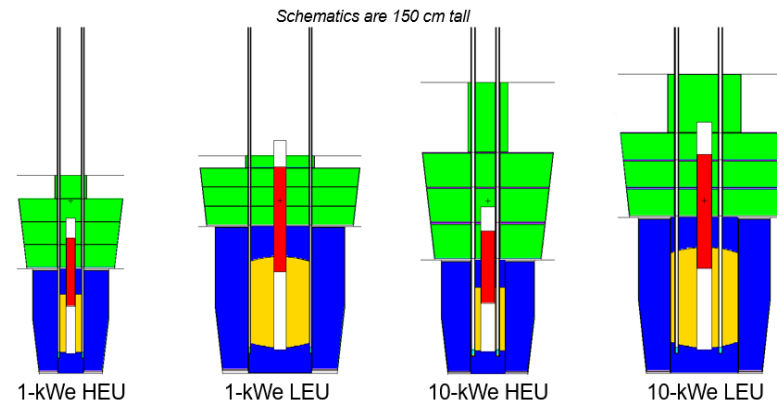
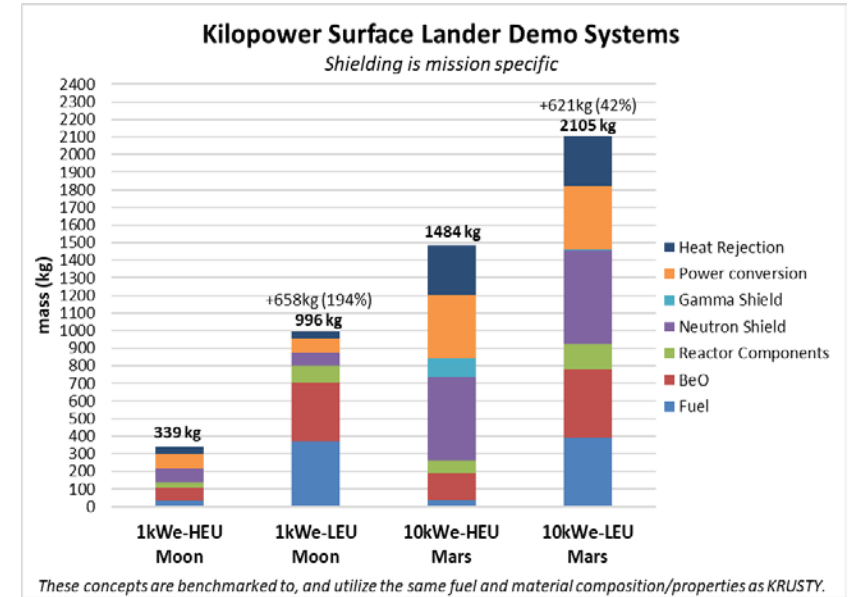
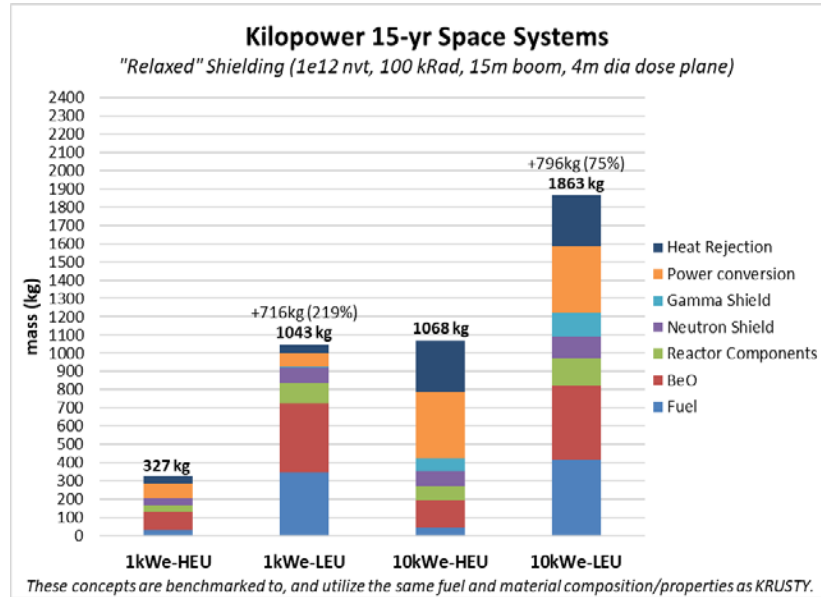

- **Launching radioactive materials**
 - Relatively common due to use of Pu-238 RTGs
 - Uranium metal has lower natural radioactivity inventory than plutonium
- **Fission criticality considerations**
 - Producing power through nuclear fission accumulates highly radioactive fission products within the reactor core
 - No intention of producing power with Kilopower core before launch
 - Prevent inadvertent criticality from occurring in the event of an accident
 - Redundant control-locks both before and after launch provide reliability to prevent inadvertent criticalities



Questions?