

Experimental Facility to Measure Power and Forces to Excavate Lunar Regolith Simulants

Margaret P. Proctor
NASA Glenn Research Center
Cleveland, Ohio

Tenth Joint Meeting of the Space Resources Roundtable and the
Planetary & Terrestrial Mining Sciences Symposium

Colorado School of Mines

Golden, Colorado, USA

June 11-14, 2019

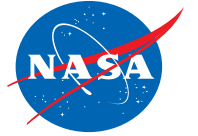

ISRU Excavation – GRC team

LMT/Margaret Proctor - Technical Lead
LMT/Phil Abel - ISRU - Excavation Element Lead
FTB[HX5 Sierra]/Tom Barkis - Electrical and controls
LMT/Steve Bauman - Design
LTT/Bilal Bomani - Enclosure
LMT/John Breckenridge - Design analysis
LMT/Colin Creager - Soil and soil bins
FA00/Scott Cutlip - Design analysis
LED/Yu Hin “Billy” Hau - APEX motion analysis & Instrumentation
LMT/Kyle Johnson - Consultant
JA00/Marla Kennedy - Soil and soil bins
LMT/Isaac Lopez(intern) - Instrumentation
LMT/Erin Rezich (co-op) - Instrumentation
LMT/Fransua Thomas - Test plan
LMT/Zachary Zoloty (intern) - Instrumentation

LMT/Damian Ludwiczak - LMT Branch Chief

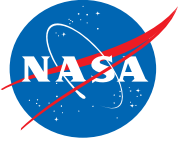

Excavation Laboratory at NASA Glenn houses APEX





Advanced Planetary Excavator (APEX)



Field demonstration of APEX at JSC mounted on Centaur 2 rover.

APEX has electrically powered linear actuators to move the digger components.

APEX can rotate 360 degrees.

2.3 meter maximum swing around radius with bucket and load cell.

208 VAC – 3 phase power is converted to 325 VDC, 100 amps to power the actuators in APEX.



APEX mounted to new stand in NASA GRC's Excavation Lab



Bucket

- 21.6-cm wide aluminum bucket
- 25.4-cm wide steel leading edge, 30° blade angle
- Three teeth can be added
 - 4.44-cm wide, 30° blade angle
 - extend 5.1 cm beyond leading edge
- Bucket volume = 15600 cm³

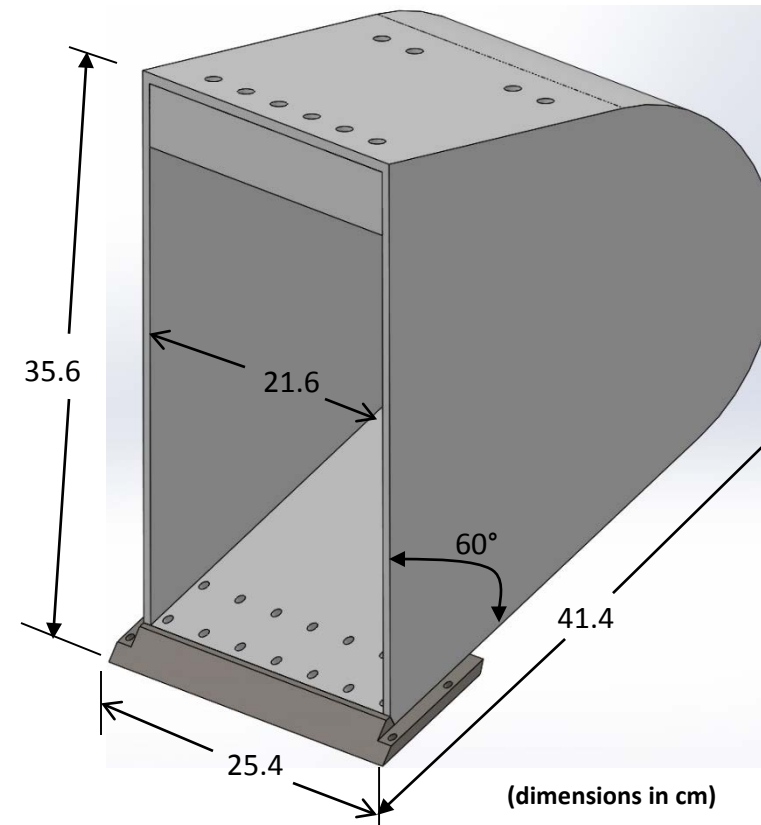
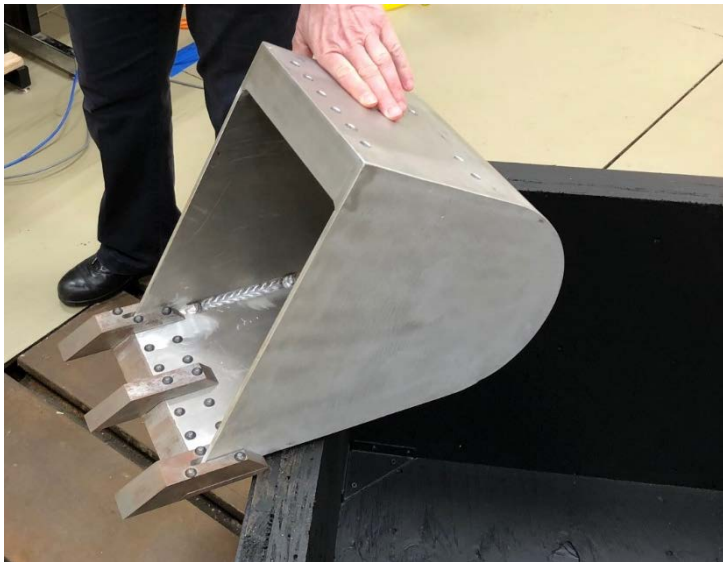

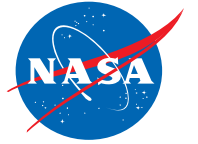

Instrumentation

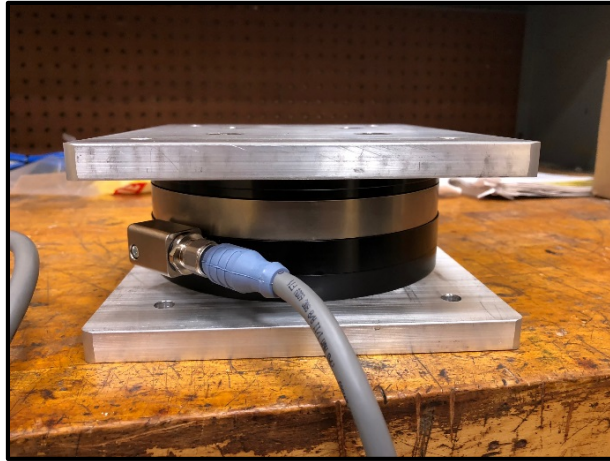

Load Cell & Adapter Plates

Range: 1300 N F_x, F_y /3900 F_z;
203 N-m T_x, T_y, T_z

Max. FS Uncertainty:
1.25% F_x, F_y, T_x, T_y
2.00% F_z and T_z

Size: 156.5 mm diameter



Yokogawa Power Meter

- Used with 50 Amp shunt to measure DC power to the APEX.

Platform scale

- 61 cm x 61 cm
- Range = 2224 N x 0.22 N



Data Acquisition and Control – LabVIEW, C-RIO, CANBUS





Soil Bins

- Pea gravel bin
 - Wooden bin painted with flame retardant paint
 - Inside dimensions: 61 W x 91 L x 51 H (cm)
- GRC-3B soil bin
 - Welded carbon steel, powder coated
 - Inside dimensions: 76.2 W x 183 L x 76 H (cm)
 - Empty weight = 2064 N
 - Filled weight not to exceed 17790 N (Crane capacity)
 - 1587 kg GRC-3B leaves about 10 cm head space
 - Sits on shaker table
- Dump bin on 61 cm x 61 cm platform scale, for delivered load.

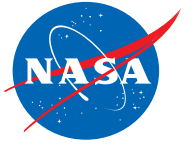

Shaker Table

For consistent soil preparation before each test.

- 81 W x 188 L x 36 H cm Custom Compaction Table
- 22.24 kN Max. load
- Carbon steel and powder coated
- 2 counter rotating 3600 rpm electric drives
- 4 Goodyear air springs
- Manual controls
- Controller with variable frequency drive, on/off switch, 0-100 Hz brakes motor starter and overload 230 V/ 3 phase in and out, NEMA 4 Enclosure

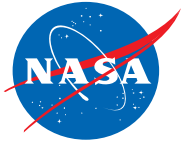

Test Objectives

- Measure the forces at the bucket and power used by APEX to dig granular material.
- Independent variables:
 - Rake angle
 - Digging depth
 - Digging trajectory
 - Density of the soil
 - Bucket features: no teeth and with teeth
- Approach:
 - Measure power & forces to dig in air and in simulant using same motion profile.
 - Subtract tare values to determine power and forces required to dig granular material.



Trajectories are planned and repeatable

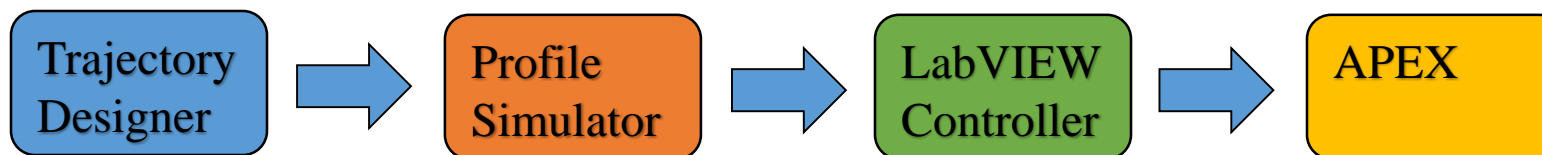
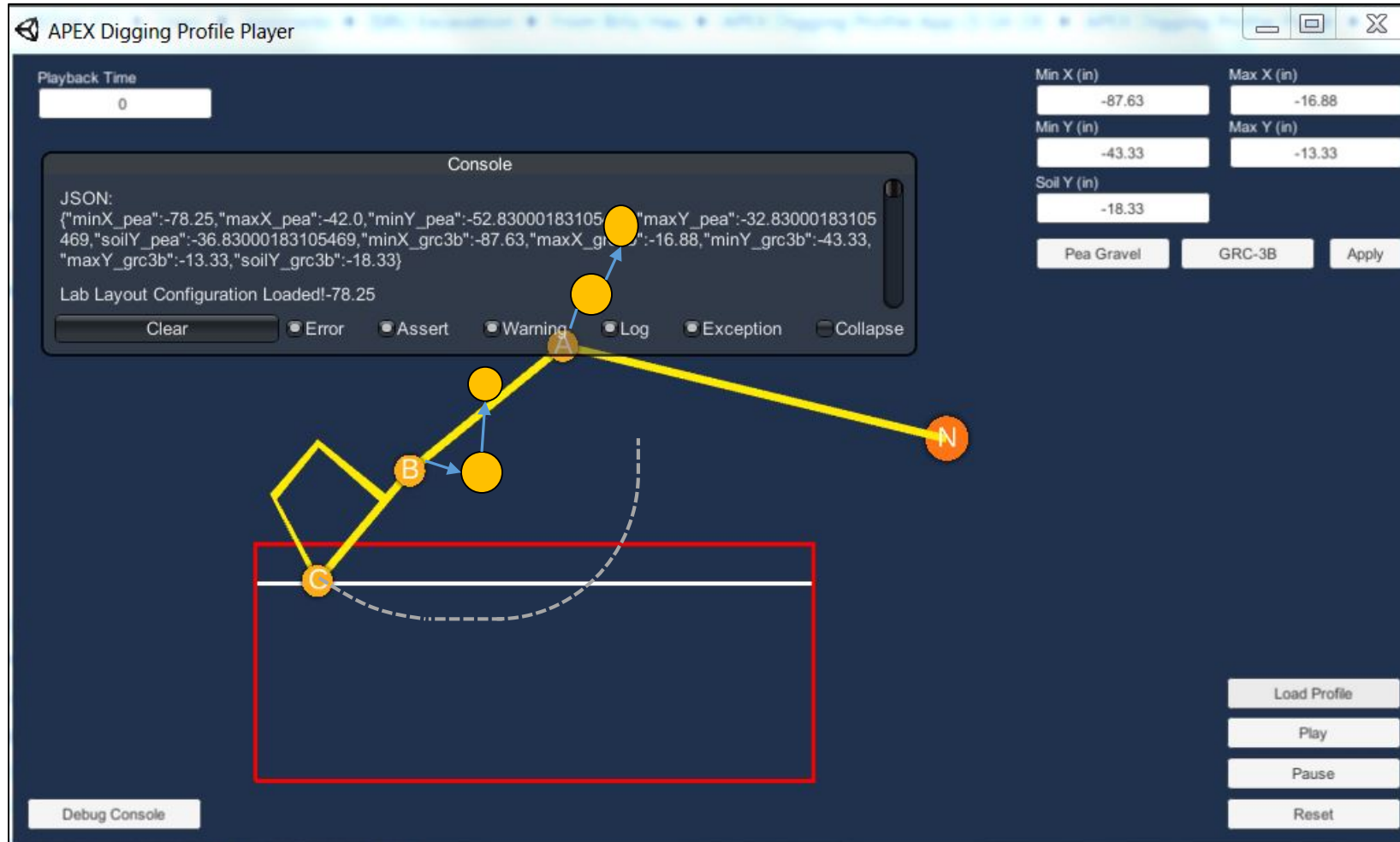

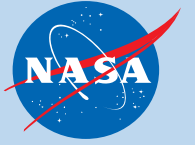

Power to move APEX in Air and GRC-3B

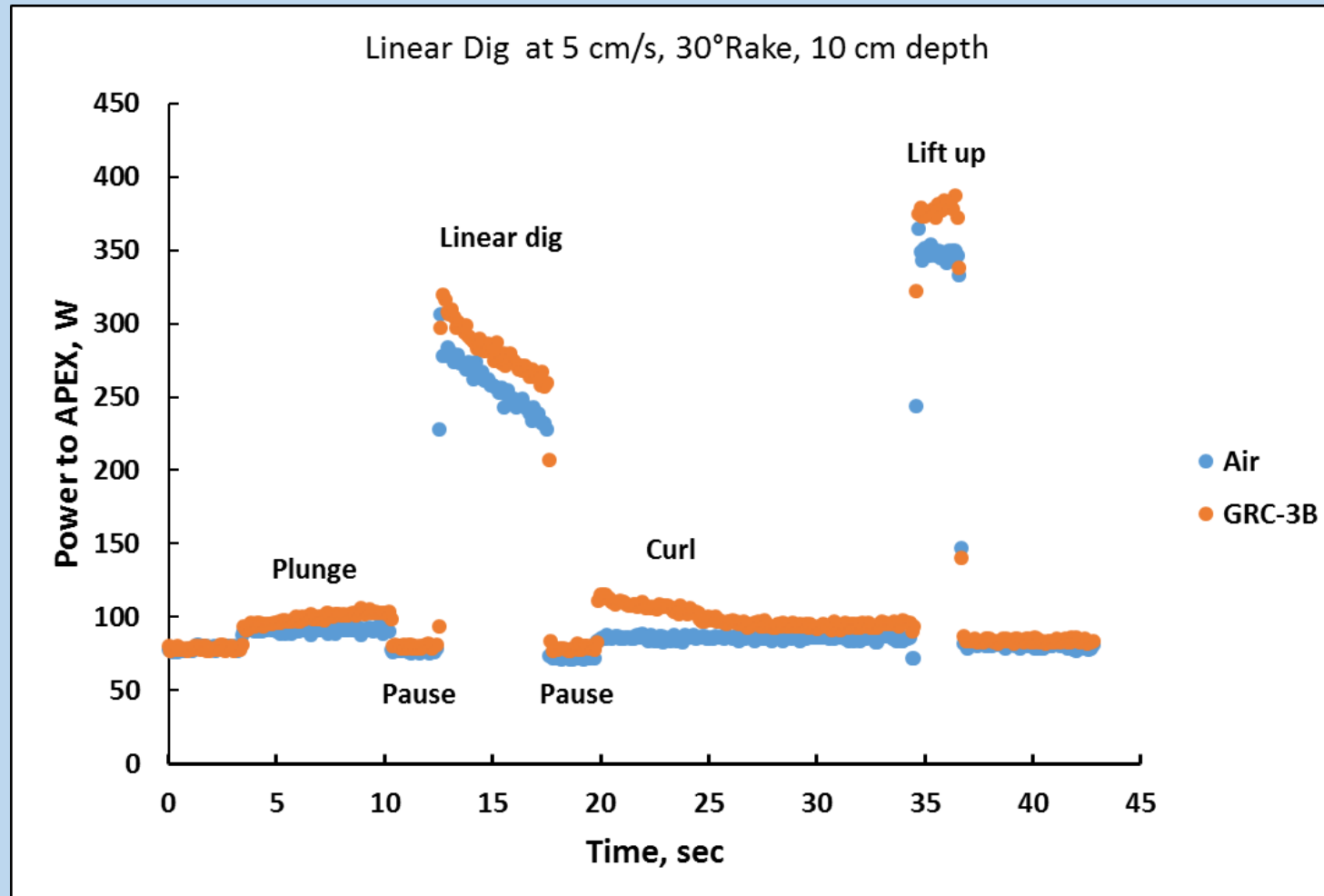

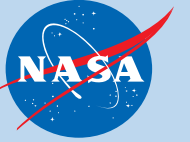

Sample Force Data from Linear Dig

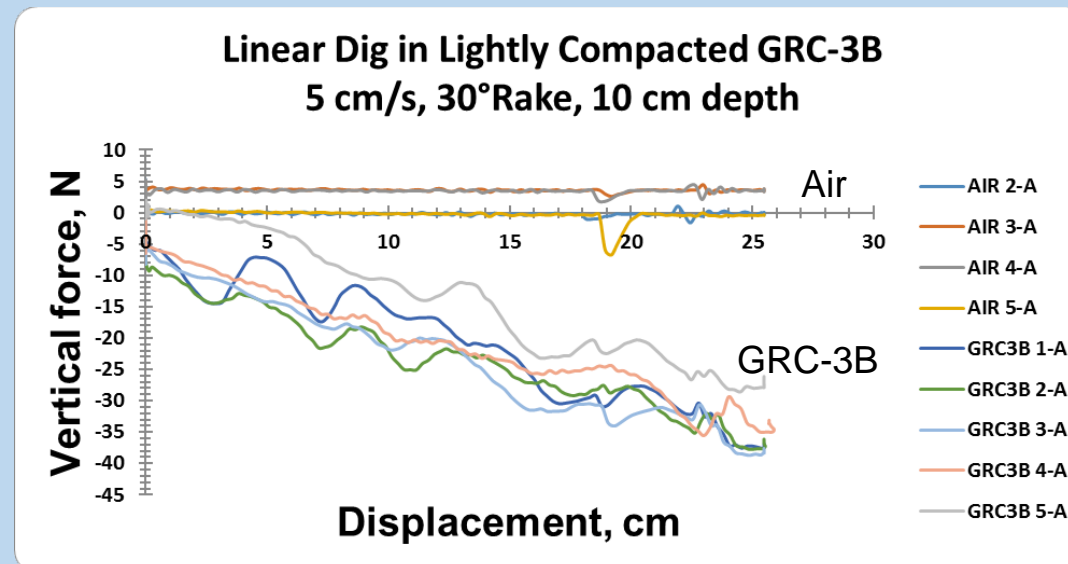
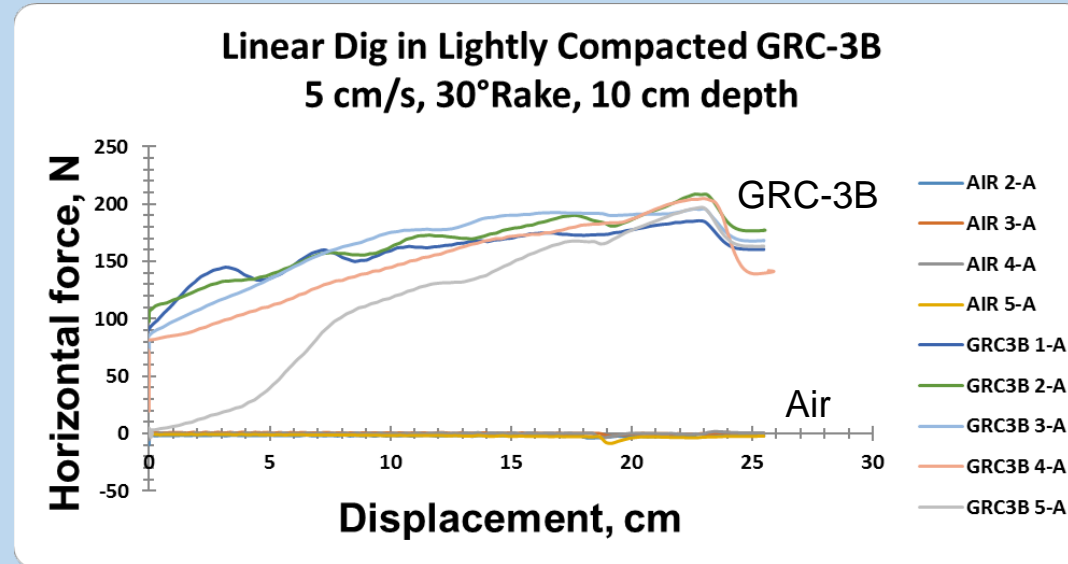

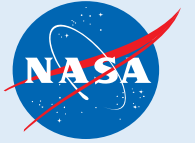

Sample results from Cone Penetrometer Tests

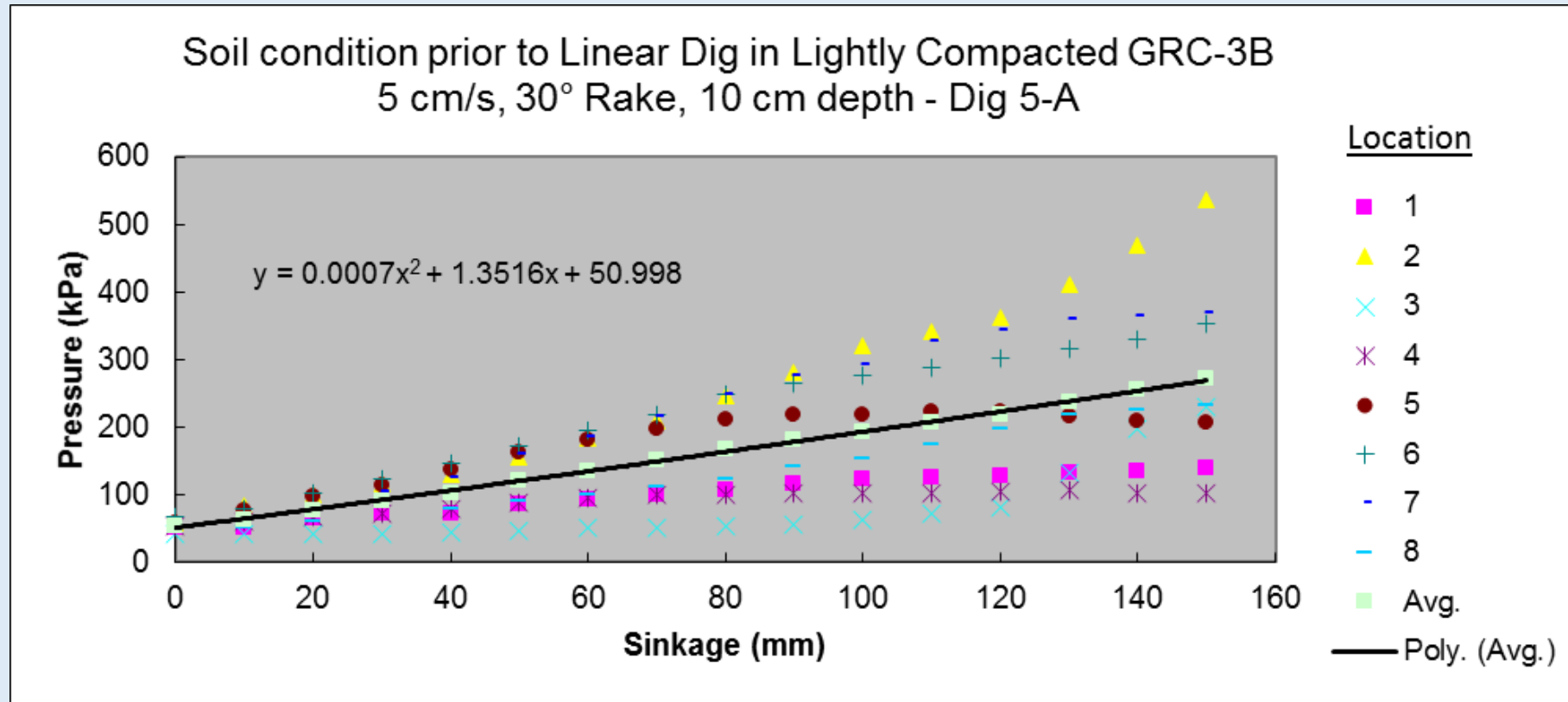

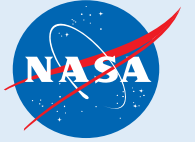

Comparison of bow wake at end of linear dig at 5 cm/s, 30° Rake, 10 cm depth

Lightly compacted



Compacted



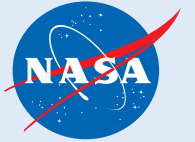

Summary

- The Excavation Lab at NASA Glenn is operational and being used to measure forces and power needed to excavate Lunar regolith simulants.
- APEX provides a stable platform for testing various digging devices and repeatable dig trajectories.
- Dust enclosure controls respiratory hazards.
- Shaker table provides various soil compaction conditions.
- A sample of preliminary data was presented.

Stay tuned for future updates!