

NASA/TM—2019–220133



# **Stress Corrosion Evaluation of Elgiloy Alloy for the ISS ECLSS—Universal Waste Management System**

*Pablo D. Torres  
Marshall Space Flight Center, Huntsville, Alabama*

---

**May 2019**

## The NASA STI Program...in Profile

Since its founding, NASA has been dedicated to the advancement of aeronautics and space science. The NASA Scientific and Technical Information (STI) Program Office plays a key part in helping NASA maintain this important role.

The NASA STI Program Office is operated by Langley Research Center, the lead center for NASA's scientific and technical information. The NASA STI Program Office provides access to the NASA STI Database, the largest collection of aeronautical and space science STI in the world. The Program Office is also NASA's institutional mechanism for disseminating the results of its research and development activities. These results are published by NASA in the NASA STI Report Series, which includes the following report types:

- **TECHNICAL PUBLICATION.** Reports of completed research or a major significant phase of research that present the results of NASA programs and include extensive data or theoretical analysis. Includes compilations of significant scientific and technical data and information deemed to be of continuing reference value. NASA's counterpart of peer-reviewed formal professional papers but has less stringent limitations on manuscript length and extent of graphic presentations.
- **TECHNICAL MEMORANDUM.** Scientific and technical findings that are preliminary or of specialized interest, e.g., quick release reports, working papers, and bibliographies that contain minimal annotation. Does not contain extensive analysis.
- **CONTRACTOR REPORT.** Scientific and technical findings by NASA-sponsored contractors and grantees.
- **CONFERENCE PUBLICATION.** Collected papers from scientific and technical conferences, symposia, seminars, or other meetings sponsored or cosponsored by NASA.
- **SPECIAL PUBLICATION.** Scientific, technical, or historical information from NASA programs, projects, and mission, often concerned with subjects having substantial public interest.
- **TECHNICAL TRANSLATION.** English-language translations of foreign scientific and technical material pertinent to NASA's mission.

Specialized services that complement the STI Program Office's diverse offerings include creating custom thesauri, building customized databases, organizing and publishing research results...even providing videos.

For more information about the NASA STI Program Office, see the following:

- Access the NASA STI program home page at <http://www.sti.nasa.gov>
- E-mail your question via the Internet to [help@sti.nasa.gov](mailto:help@sti.nasa.gov)
- Phone the NASA STI Help Desk at 757-864-9658
- Write to:  
NASA STI Information Desk  
Mail Stop 148  
NASA Langley Research Center  
Hampton, VA 23681-2199, USA

NASA/TM—2019–220133



# **Stress Corrosion Evaluation of Elgiloy Alloy for the ISS ECLSS—Universal Waste Management System**

*Pablo D. Torres*  
*Marshall Space Flight Center, Huntsville, Alabama*

National Aeronautics and  
Space Administration

Marshall Space Flight Center • Huntsville, Alabama 35812

---

**May 2019**

## **Acknowledgments**

The author wishes to acknowledge the contributions of the following supporters from Marshall Space Flight Center: A. Richardson from the Transportation and Logistics Engineering Office; A. Brown from the Human Exploration Development and Operations Chief Engineers Office; H. Gibson, A. Girgis, L. Sharff, C. Harris, and C. Bosley from the Materials Test, Chemistry, and Contamination Control Branch; S. Shah and F. Lowery from the Metals Engineering Division; B. Panda, G. Jerman, J. Hastings, J. Honeycutt, and I. Hanson from Materials Science and Metallurgy Branch; J. Street, M. Barnes, and R. Lee from the Metal Processes and Manufacturing Branch; L. Foreman from the Materials and Processes Engineering Support Office; J. Hill from the Mechanical Design, Analysis and Fabrication Division; D. Carter and D. Long from the Environmental Control and Life Support System Development Branch; K. Presson from the International Space Station Projects Office; and S. LeCroix and P. White from the Mechanical Fabrication Branch.

## **TRADEMARKS**

Trade names and trademarks are used in this report for identification only. This usage does not constitute an official endorsement, either expressed or implied, by the National Aeronautics and Space Administration.

Available from:

NASA STI Information Desk  
Mail Stop 148  
NASA Langley Research Center  
Hampton, VA 23681-2199, USA  
757-864-9658

This report is also available in electronic form at  
<<http://www.sti.nasa.gov>>

## TABLE OF CONTENTS

1. INTRODUCTION .....	1
2. EXPERIMENTAL PROCEDURE .....	2
3. RESULTS AND DISCUSSION .....	11
4. CONCLUSIONS.....	34
APPENDIX A—CERTIFICATE OF CONFORMANCE FOR ELGILOY .....	35
APPENDIX B—INSPECTION CERTIFICATE FOR ELGILOY .....	36
APPENDIX C—TENSILE DATA FOR ELGILOY .....	37
REFERENCES .....	39

## LIST OF FIGURES

1.	Drawing of stress corrosion specimen .....	3
2.	View of representative Elgiloy stress corrosion specimen as received .....	3
3.	Stress-strain curves for Elgiloy nonexposed specimens .....	4
4.	Double-beam assembly .....	5
5.	H-fixture for bent-beam stress corrosion assembly .....	6
6.	Rocker for bent-beam stress corrosion assembly .....	6
7.	Tools to load beam specimens and representative assembled samples .....	7
8.	Appearance of the stressed samples loaded to different percentages of the YS .....	7
9.	Magnified views of representative stressed samples exposed at 90% of YS: (a) Exposed to concentrated alternate pretreat stabilizer solution, (b) exposed to diluted alternate pretreat stabilizer solution, and (c) exposed to 3.5% NaCl alternate immersion .....	8
10.	Samples being tested by complete immersion in the diluted ECLSS solution .....	9
11.	Samples being tested by complete immersion in the concentrated ECLSS solution ...	9
12.	Samples being tested by alternate immersion in 3.5% NaCl solution .....	10
13.	Samples exposed to concentrated alternate pretreat stabilizer for 365 days and subjected to post-test evaluations: (a) Used for metallographic analysis and (b) tensile tested .....	11
14.	Samples exposed to diluted alternate pretreat stabilizer for 365 days and subjected to post-test evaluations: (a) Used for metallographic analysis and (b) tensile tested .....	12
15.	Samples exposed to 3.5% NaCl alternate immersion for 365 days and subjected to post-test evaluations: (a) Used for metallographic analysis and (b) tensile tested .....	12

## LIST OF FIGURES (Continued)

16.	Graphical representation comparing baseline and post-exposure tensile data values .....	16
17.	Stress-strain curves for normalized values for nonexposed and exposed specimens: (a) Normalized no exposure/baseline values, (b) normalized concentrated alternate pretreat stabilizer, (c) normalized diluted alternate pretreat stabilizer, and (d) normalized 3.5% NaCl alternate immersion .....	17
18.	Stress-strain curves for averages of normalized values .....	18
19.	Metallographic and overall views of Elgiloy specimen No. E1, exposed unstressed to concentrated alternate pretreat stabilizer for 365 days: (a) $\times 50$ , unetched, (b) $\times 500$ , unetched, (c) $\times 1,000$ , unetched, and (d) $\times 1$ .....	19
20.	Metallographic and overall views of Elgiloy specimen No. E21, stressed to 25% YS (45.8 ksi), and exposed to concentrated alternate pretreat stabilizer for 365 days: (a) $\times 50$ , unetched, (b) $\times 500$ , unetched, (c) $\times 1,000$ , unetched, and (d) $\times 1$ .....	20
21.	Metallographic and overall views of Elgiloy specimen No. E38, stressed to 50% YS (91.5 ksi), and exposed to concentrated alternate pretreat stabilizer for 365 days: (a) $\times 50$ , unetched, (b) $\times 500$ , unetched, (c) $\times 1,000$ , unetched, and (d) $\times 1$ .....	21
22.	Metallographic and overall views of Elgiloy specimen No. E15, stressed to 75% YS (137.3 ksi), and exposed to concentrated alternate pretreat stabilizer for 365 days: (a) $\times 50$ , unetched, (b) $\times 500$ , unetched, (c) $\times 1,000$ , unetched, and (d) $\times 1$ .....	22
23.	Metallographic and overall views of Elgiloy specimen No. E49, stressed to 90% YS (164.7 ksi), and exposed to concentrated alternate pretreat stabilizer for 365 days: (a) $\times 50$ , unetched, (b) $\times 500$ , unetched, (c) $\times 1,000$ , unetched, and (d) $\times 1$ .....	23
24.	Metallographic and overall views of Elgiloy specimen No. E3, exposed unstressed to diluted alternate pretreat stabilizer for 365 days: (a) $\times 50$ , unetched, (b) $\times 500$ , unetched, (c) $\times 1,000$ , unetched, and (d) $\times 1$ .....	24
25.	Metallographic and overall views of Elgiloy specimen No. E23, stressed to 25% YS (45.8 ksi), and exposed to diluted alternate pretreat stabilizer for 365 days: (a) $\times 50$ , unetched, (b) $\times 500$ , unetched, (c) $\times 1,000$ , unetched, and (d) $\times 1$ .....	25

## LIST OF FIGURES (Continued)

26.	Metallographic and overall views of Elgiloy specimen No. E10, stressed to 50% YS (91.5 ksi), and exposed to diluted alternate pretreat stabilizer for 365 days: (a) $\times 50$ , unetched, (b) $\times 500$ , unetched, (c) $\times 1,000$ , unetched, and (d) $\times 1$ .....	26
27.	Metallographic and overall views of Elgiloy specimen No. E17, stressed to 75% YS (137.3 ksi), and exposed to diluted alternate pretreat stabilizer for 365 days: (a) $\times 50$ , unetched, (b) $\times 500$ , unetched, (c) $\times 1,000$ , unetched, and (d) $\times 1$ ....	27
28.	Metallographic and overall views of Elgiloy specimen No. E53, stressed to 90% YS (164.7 ksi), and exposed to diluted alternate pretreat stabilizer for 365 days: (a) $\times 50$ , unetched, (b) $\times 500$ , unetched, (c) $\times 1,000$ , unetched, and (d) $\times 1$ ....	28
29.	Metallographic and overall views of Elgiloy specimen No. E5, exposed unstressed to 3.5% NaCl alternate immersion for 365 days: (a) $\times 50$ , unetched, (b) $\times 500$ , unetched, (c) $\times 1,000$ , unetched, and (d) $\times 1$ .....	29
30.	Metallographic and overall views of Elgiloy specimen No. E25, stressed to 25% YS (45.8 ksi) and exposed to 3.5% NaCl alternate immersion for 365 days: (a) $\times 50$ , unetched, (b) $\times 500$ , unetched, (c) $\times 1,000$ , unetched, and (d) $\times 1$ .....	30
31.	Metallographic and overall views of Elgiloy specimen No. E12, stressed to 50% YS (91.5 ksi) and exposed to 3.5% NaCl alternate immersion for 365 days: (a) $\times 50$ , unetched, (b) $\times 500$ , unetched, (c) $\times 1,000$ , unetched, and (d) $\times 1$ .....	31
32.	Metallographic and overall views of Elgiloy specimen No. E66, stressed to 75% YS (137.3 ksi) and exposed to 3.5% NaCl alternate immersion for 365 days: (a) $\times 50$ , unetched, (b) $\times 500$ , unetched, (c) $\times 1,000$ , unetched, and (d) $\times 1$ .....	32
33.	Metallographic and overall views of Elgiloy specimen No. E55, stressed to 90% YS (164.7 ksi) and exposed to 3.5% NaCl alternate immersion for 365 days: (a) $\times 50$ , unetched, (b) $\times 500$ , unetched, (c) $\times 1,000$ , unetched, and (d) $\times 1$ .....	33
34.	Certificate of conformance for Elgiloy .....	35
35.	Inspection certificate for Elgiloy .....	36



## LIST OF TABLES

1.	Chemical composition of Elgiloy .....	2
2.	Baseline tensile data for Elgiloy .....	4
3.	Solutions used for stress corrosion testing of Elgiloy .....	8
4.	Stress corrosion test results of Elgiloy after a year-long exposure .....	11
5.	Tensile strength data for Elgiloy specimens following a year-long exposure to concentrated alternate pretreat stabilizer .....	13
6.	Tensile strength data for Elgiloy specimens following a year-long exposure to diluted alternate pretreat stabilizer .....	14
7.	Tensile strength data for Elgiloy specimens following a year-long exposure to 3.5% NaCl alternate immersion .....	15
8.	Compiled tensile data for Elgiloy .....	37

## LIST OF ACRONYMS, DESIGNATORS, AND SYMBOLS

AMS	Aerospace Material Specification
ASTM	American Society for Testing and Materials
CL	centerline
ECLSS	Environmental Control and Life Support System
ISS	International Space Station
NaCl	sodium chloride
Ti6Al4V	titanium with 6% aluminum and 4% vanadium
UNC	Unified National Course
UNS	unified numbering system
UTS	ultimate tensile strength
YS	yield strength (0.2% offset)

## NOMENCLATURE

$a$	distance from center of bolt to closest support of H-fixture (in)
$\Delta D$	deflection (in) measured at centerline of bolts
$E$	modulus of elasticity (psi)
$L$	distance from the center of one bolt to the center of the other bolt (in)
$S$	desired tensile stress (psi) at center of beam
$t$	thickness of specimen (in)



## TECHNICAL MEMORANDUM

### **STRESS CORROSION EVALUATION OF ELGILOY ALLOY FOR THE ISS ECLSS—UNIVERSAL WASTE MANAGEMENT SYSTEM**

#### **1. INTRODUCTION**

Elgiloy® alloy (UNS R30003)—a spring material per AMS 5876D (reference 1)—is one among several alloys recently evaluated for stress corrosion cracking resistance in support of the International Space Station (ISS) Environmental Control and Life Support System (ECLSS). Elgiloy was evaluated particularly for its expected use in the Universal Waste Management System (described in references 2 and 3). Data for other alloys previously evaluated were reported in references 4 and 5. Materials included in reference 4 are Inconel 625, Hastelloy® C276, commercially pure titanium, titanium with 6% aluminum and 4% vanadium (Ti6Al4V), extra-low interstitial Ti6Al4V, and Cronidur 30. The results for Nitinol 60 are in reference 5. During the water recovery process, the metallic components fabricated from these materials are exposed to acidic solutions used for waste treatment. The purpose of the current and previous stress corrosion evaluations is to determine if these materials have adequate stress corrosion resistance.

## 2. EXPERIMENTAL PROCEDURE

The material used for this evaluation was obtained from Elgiloy Specialty Metals in the form of a 0.05-in-thick sheet per AMS 5876D (lot No. 306422, heat No. L2066). The chemical composition limits of this alloy per AMS 5876D and the mill analysis are presented in table 1. The certificate of conformance and inspection certificate obtained from Elgiloy Specialty Metals are shown in appendices A and B, respectively. The specimens for this evaluation were fabricated per drawing shown in figure 1. A view of a representative fabricated sample is shown in figure 2.

Table 1. Chemical composition of Elgiloy alloy.

Element	Limits per AMS 5876D (Weight %)	Elgiloy Specialty Metals Mill Analysis (Weight %)
Carbon	0.15 max.	0.04
Manganese	1.5–2.5	1.91
Silicon	1.20 max.	0.4
Phosphorus	0.015 max.	0.009
Sulfur	0.015 max.	0.001
Chromium	19.0–21.0	19.4
Nickel	14.0–16.0	15.5
Cobalt	39.0–41.0	39.6
Molybdenum	6.0–8.0	7.1
Beryllium	0.10 max.	<0.0001
Iron	Remainder	15.6
Copper	Not listed	0.045
Titanium	Not listed	0.02
Aluminum	Not listed	0.01
Nitrogen	Not listed	0.02
Tantalum	Not listed	<0.002
Vanadium	Not listed	0.1
Boron	Not listed	<0.0005
Columbium	Not listed	0.1
Lead	Not listed	<0.0001
Tungsten	Not listed	<0.004
Silver	Not listed	<0.0003
Nickel + Cobalt	–	55.1

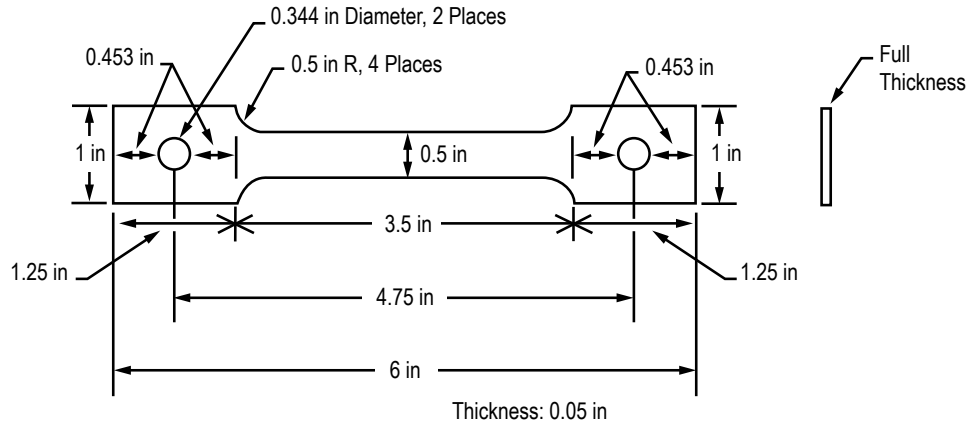

Figure 1. Drawing of stress corrosion specimen.



Figure 2. View of representative Elgiloy stress corrosion specimen as received.

Six specimens were tensile tested to obtain baseline tensile data, and the results are presented in table 2. The average ultimate tensile strength (UTS), 0.2% offset yield strength (YS), fracture elongation, and modulus of elasticity (E) were 215 ksi, 183 ksi, 8.4%, and 25.6 Msi, respectively. Figure 3 shows the stress-strain curves obtained from this testing.

Table 2. Baseline tensile data for Elgiloy.

Specimen ID	UTS (ksi)	0.2% Offset YS (ksi)	Fracture Elongation (%)	E** (Msi)
Elgiloy-7	217	187	8.3	26.3
Elgiloy-14	217	185	8.0	25.4
Elgiloy-29	215	183	8.5	25.7
Elgiloy-40	211	179	9.5	25.3
Elgiloy-50	214	182	7.6	25.4
Elgiloy-65	217	183	8.3	25.7
<b>Averages</b>	<b>215</b>	<b>183</b>	<b>8.4</b>	<b>25.6</b>

\* The data in this table was obtained in air with specimens that were not exposed to any corrosive environments.

\*\* Elgiloy Specialty Metals reports a modulus of 27 Msi for Elgiloy.

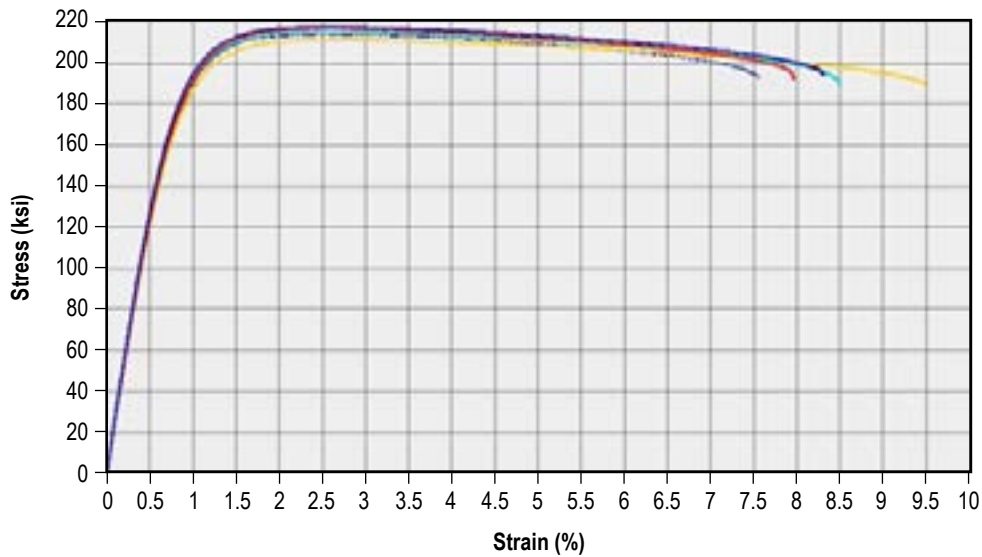

Figure 3. Stress-strain curves for Elgiloy nonexposed specimens.



The remaining of the specimens were loaded per references 6 and 7 to various percentages of the YS by using the double-beam method. The stress levels were 0%, 25%, 50%, 75%, and 90% of YS. The specimens were tested in quadruplicate. Figure 4 shows a schematic diagram of the double-beam assembly.

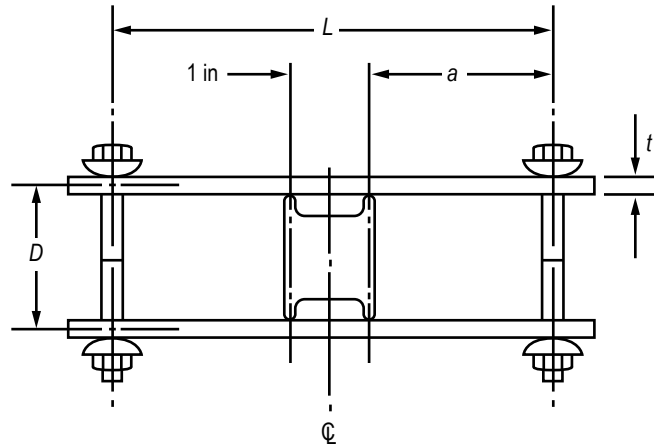

Figure 4. Double-beam assembly.

Equation (1) is the formula used to calculate the deflection:<sup>7</sup>

$$D = \frac{2Sa(3L - 4a)}{3Et} \quad (1)$$

where

- $\Delta D$  = deflection (in) measured at centerline of bolts,
- $S$  = desired tensile stress (psi) at center of beam,
- $L, a, t$  = marked on drawing (in), and
- $E$  = modulus of elasticity (psi).

Figures 5 and 6 show the H-fixture and rocker, respectively, which are components of the stressing assembly, and were fabricated from PH 13-8 Mo stainless steel material. CRES 18-8 bolts with 5/16-18 threads were used as part of the assembly. Figure 7 shows the tools used for loading the samples as well as two fully assembled samples. The appearance of the samples loaded to different percentages of the yield strength and corresponding deflection values are shown in figure 8 for one of the three sets tested. Figure 9 shows close views of representative samples loaded to 90% of the YS.

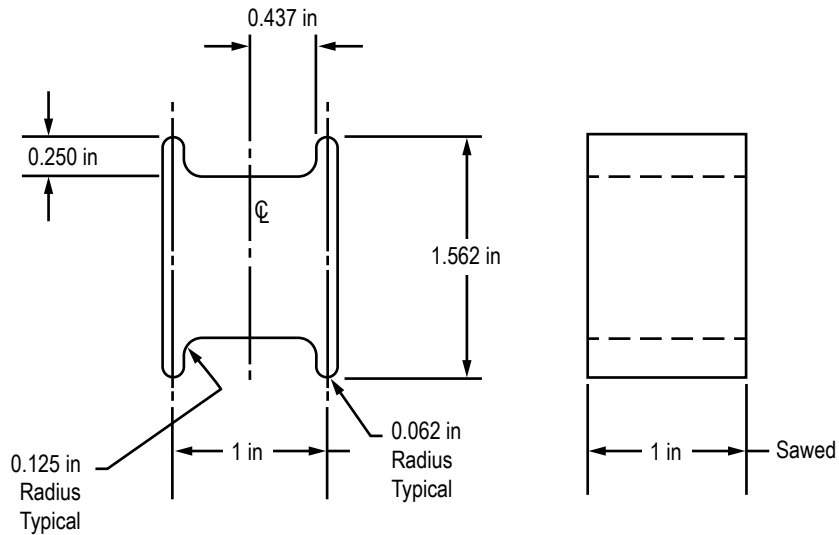

Figure 5. H-fixture for bent-beam stress corrosion assembly.

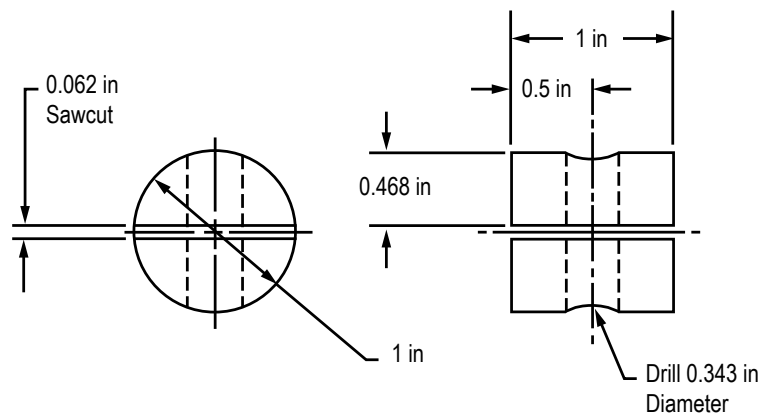

Figure 6. Rocker for bent-beam stress corrosion assembly.



Figure 7. Tools to load beam specimens and representative assembled samples.

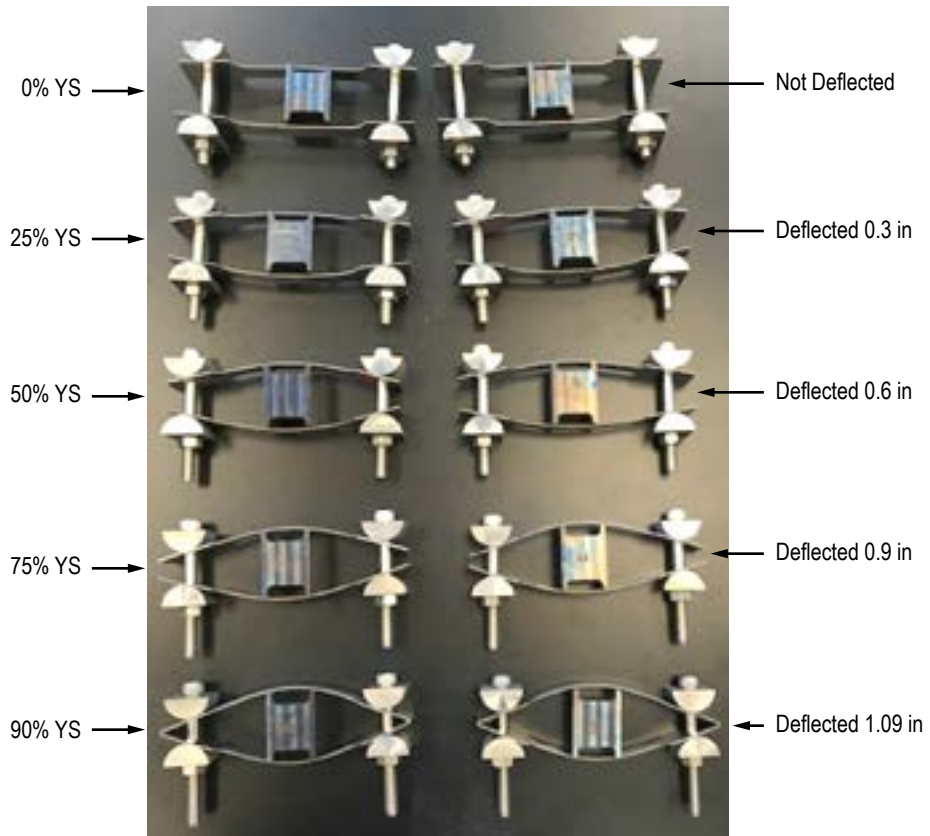

Figure 8. Appearance of the stressed samples loaded to different percentages of the YS.

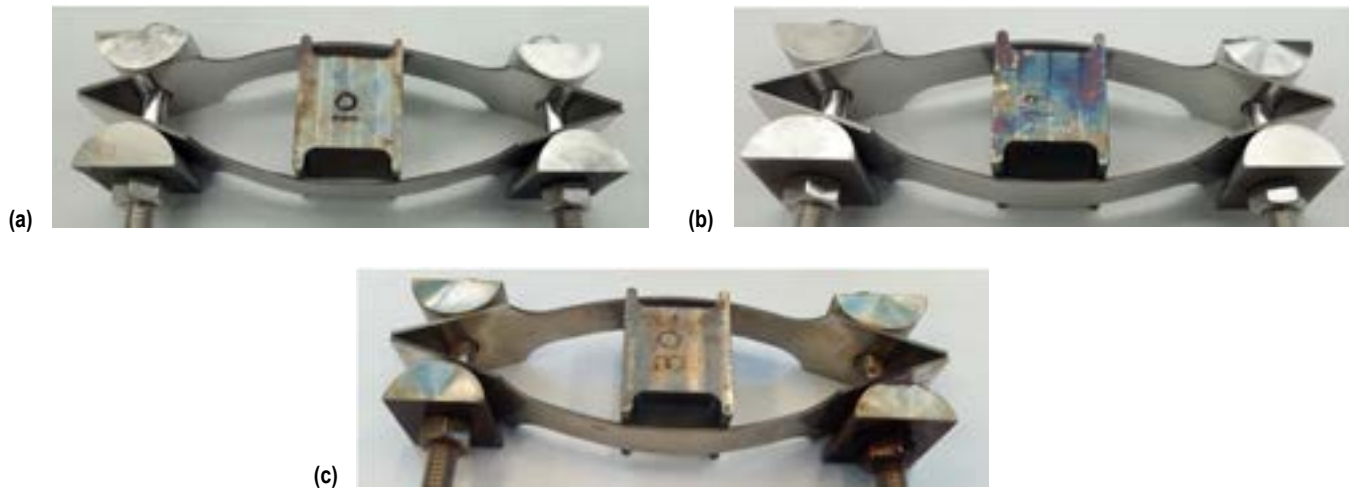

Figure 9. Magnified views of representative stressed samples exposed at 90% of YS: (a) Exposed to concentrated alternate pretreat stabilizer solution, (b) exposed to diluted alternate pretreat stabilizer solution, and (c) exposed to 3.5% NaCl alternate immersion.

After the samples were loaded, they were exposed to concentrated alternate pretreatment (pretreat) stabilizer, diluted pretreat stabilizer, and to 3.5% sodium chloride (NaCl) alternate immersion per reference 8 in replicates of four. Table 3 describes how these solutions were prepared. Exposure in the pretreat solutions was by complete immersion. In the alternate immersion test, for each hour, the samples were exposed to two cycles, an immersion cycle of 10 min, and a drying cycle of 50 min. Those cycles were repeated for the entire length of the test. The pH of the solution during alternate immersion testing was in the range of 6.4 to 7.2. The humidity and temperature conditions in the room were  $45 \pm 10\%$  relative and  $80 \pm 2$  °F, respectively. Figures 10–12 show the specimens in test. Test duration in all environments was 1 yr (365 days).

Table 3. Solutions used for stress corrosion testing of Elgiloy.

Solution	Procedure for Making the Solution
Concentrated alternate pretreat stabilizer	Made by adding 284.8 ml of oxidizer with 715.2 ml of phosphoric acid (85%). The oxidizer is made by adding 300 g of CrO <sub>3</sub> with 700 g of deionized water.
Diluted alternate pretreat stabilizer	Made by adding 3.3 ml of alternate pretreat stabilizer and 50 ml of deionized water.
3.5% NaCl	The solution was prepared by dissolving $3.5 \pm 0.1$ parts by weight of reagent grade NaCl in 96.5 parts of deionized water.



Figure 10. Samples being tested by complete immersion in the diluted ECLSS solution.



Figure 11. Samples being tested by complete immersion in the concentrated ECLSS solution.



Figure 12. Samples being tested by alternate immersion in 3.5% NaCl solution.

### 3. RESULTS AND DISCUSSION

None of the specimens failed in this test after a year-long exposure, as shown in table 4. After the exposure was completed, the specimens were removed from the environments, washed with water, and disassembled. The specimens subjected to the highest stress levels suffered the most permanent deformation, especially those stressed to 90% YS. For each set of four specimens at the same condition, one was subjected to metallography, and three were tensile tested to determine reduction in tensile strength. The total number of specimens subjected to metallography and tensile testing at the end of the exposure were 15 and 45, respectively. The specimens are shown in figures 13–15.

Table 4. Stress corrosion test results of Elgiloy after a year-long exposure.

Environment	Stress Level (% YS)	Stress Level (ksi)	Failure Ratio
Complete immersion in concentrated phosphoric acid based solution (alternate pretreat stabilizer)	0	0	0/4
	25	45.8	0/4
	50	91.5	0/4
	75	137.3	0/4
	90	164.7	0/4
Complete immersion in diluted phosphoric acid based solution (diluted alternate pretreat stabilizer)	0	0	0/4
	25	45.8	0/4
	50	91.5	0/4
	75	137.3	0/4
	90	164.7	0/4
Alternate immersion in 3.5% NaCl	0	0	0/4
	25	45.8	0/4
	50	91.5	0/4
	75	137.3	0/4
	90	164.7	0/4

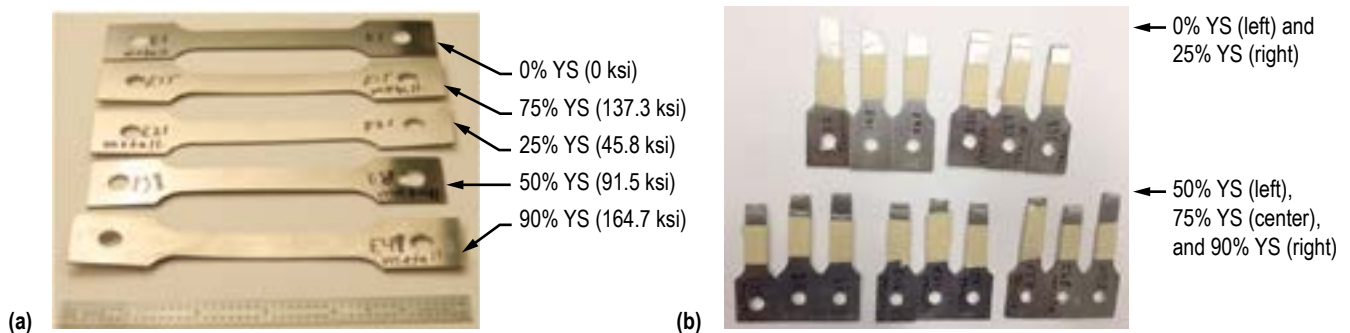

Figure 13. Samples exposed to concentrated alternate pretreat stabilizer for 365 days and subjected to post-test evaluations: (a) Used for metallographic analysis and (b) tensile tested.



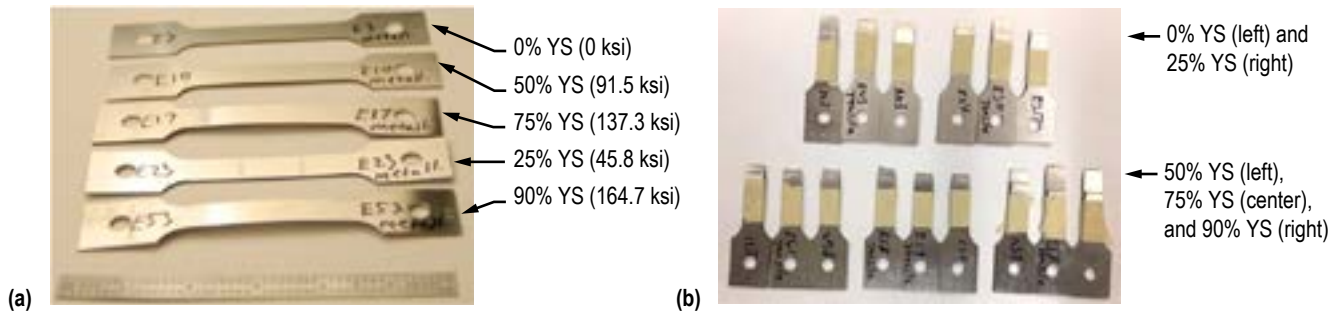

Figure 14. Samples exposed to diluted alternate pretreat stabilizer for 365 days and subjected to post-test evaluations: (a) Used for metallographic analysis and (b) tensile tested.

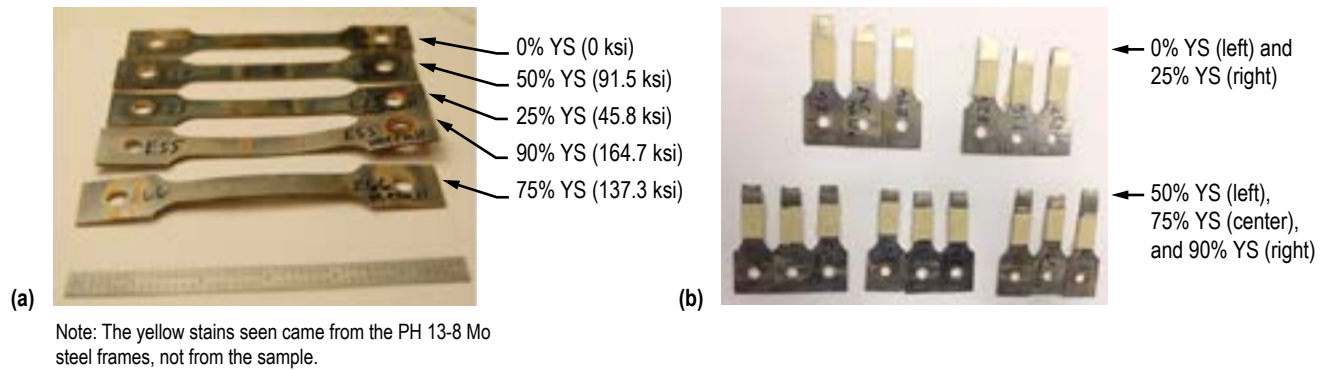

Figure 15. Samples exposed to 3.5% NaCl alternate immersion for 365 days and subjected to post-test evaluations: (a) Used for metallographic analysis and (b) tensile tested.

Tables 5–7 show the tensile tests results after exposure. These tests had the purpose of determining if there was any reduction in tensile strength on the material resulting from exposure. As seen in those tables, no reduction in tensile strength occurred. The prevalent tendency was for the UTS values to be higher than the initial baseline values obtained before the test with non-exposed specimens. A graphical representation comparing baseline and final values for UTS, YS, modulus of elasticity, and elongation is presented in figure 16. Figure 17 shows stress-strain curves for normalized values for nonexposed and exposed specimens, and figure 18 illustrates the averages of these normalized values. All tensile data values used to generate these illustrations are presented in appendix C. Metallographic evaluations were performed and no stress corrosion was observed in any of the samples. Metallographic views are presented in figures 19–33.



Table 5. Tensile strength data for Elgiloy specimens following a year-long exposure to concentrated alternate pretreat stabilizer.

Specimen Number	Stress Level (% YS)	Stress Level (ksi)	Averaged UTS for Baseline Values (Non-Exposed Specimens) (ksi)	UTS for Exposed Specimen (ksi)	UTS Ratio of Exposed to Averaged Baseline Value	Evaluation Performed	Passed or Failed
E1	0	0	215	N/A	N/A	Metallography	Passed
E2	0	0	215	219	1.019	Tensile Test	Passed
E41	0	0	215	223	1.037	Tensile Test	Passed
E42	0	0	215	215	1.000	Tensile Test	Passed
			Averages→	<b>219</b>	<b>1.019</b>		
E21	25	45.8	215	N/A	N/A	Metallography	Passed
E22	25	45.8	215	217	1.009	Tensile Test	Passed
E27	25	45.8	215	220	1.023	Tensile Test	Passed
E28	25	45.8	215	220	1.023	Tensile Test	Passed
			Averages→	<b>219</b>	<b>1.018</b>		
E38	50	91.5	215	N/A	N/A	Metallography	Passed
E39	50	91.5	215	213	0.991	Tensile Test	Passed
E8	50	91.5	215	220	1.023	Tensile Test	Passed
E9	50	91.5	215	219	1.019	Tensile Test	Passed
			Averages→	<b>217</b>	<b>1.011</b>		
E15	75	137.3	215	N/A	N/A	Metallography	Passed
E16	75	137.3	215	218	1.014	Tensile Test	Passed
E51	75	137.3	215	217	1.009	Tensile Test	Passed
E52	75	137.3	215	221	1.028	Tensile Test	Passed
			Averages→	<b>219</b>	<b>1.017</b>		
E49	90	164.7	215	N/A	N/A	Metallography	Passed
E57	90	164.7	215	223	1.037	Tensile Test	Passed
E68	90	164.7	215	221	1.028	Tensile Test	Passed
E60	90	164.7	215	224	1.042	Tensile Test	Passed
			Averages→	<b>223</b>	<b>1.036</b>		

\* The alternate pretreat stabilizer is a concentrated phosphoric acid based solution. The test was performed by complete immersion in the solution. All specimens passed because no stress corrosion features were detected with metallography and no reduction in load carrying ability occurred.

Table 6. Tensile strength data for Elgiloy specimens following a year-long exposure to diluted alternate pretreat stabilizer.

Specimen Number	Stress Level (% YS)	Stress Level (ksi)	Averaged UTS for Baseline Values (Non-Exposed Specimens) (ksi)	UTS for Exposed Specimen (ksi)	UTS Ratio of Exposed to Averaged Baseline Value	Evaluation Performed	Passed or Failed
E3	0	0	215	N/A	NA	Metallography	Passed
E4	0	0	215	220	1.023	Tensile Test	Passed
E43	0	0	215	220	1.023	Tensile Test	Passed
E44	0	0	215	221	1.028	Tensile Test	Passed
			Averages→	<b>220</b>	<b>1.025</b>		
E23	25	45.8	215	N/A	NA	Metallography	Passed
E24	25	45.8	215	220	1.023	Tensile Test	Passed
E30	25	45.8	215	221	1.028	Tensile Test	Passed
E35	25	45.8	215	220	1.023	Tensile Test	Passed
			Averages→	<b>220</b>	<b>1.025</b>		
E10	50	91.5	215	N/A	NA	Metallography	Passed
E11	50	91.5	215	222	1.033	Tensile Test	Passed
E61	50	91.5	215	223	1.037	Tensile Test	Passed
E62	50	91.5	215	219	1.019	Tensile Test	Passed
			Averages→	<b>221</b>	<b>1.030</b>		
E17	75	137.3	215	NA	NA	Metallography	Passed
E18	75	137.3	215	220	1.023	Tensile Test	Passed
E19	75	137.3	215	220	1.023	Tensile Test	Passed
E20	75	137.3	215	222	1.033	Tensile Test	Passed
			Averages→	<b>221</b>	<b>1.026</b>		
E53	90	164.7	215	NA	NA	Metallography	Passed
E54	90	164.7	215	220	1.023	Tensile Test	Passed
E58	90	164.7	215	221	1.028	Tensile Test	Passed
E59	90	164.7	215	224	1.042	Tensile Test	Passed
			Averages→	<b>222</b>	<b>1.031</b>		

\* The diluted alternate pretreat stabilizer is a phosphoric acid based solution. The test was performed by complete immersion in the solution. All specimens passed because no stress corrosion features were detected with metallography and no reduction in load carrying ability occurred.

Table 7. Tensile strength data for Elgiloy specimens following a year-long exposure to 3.5% NaCl alternate immersion.

Specimen Number	Stress Level (% YS)	Stress Level (ksi)	Averaged UTS for Base-line Values (Non-Exposed Specimens) (ksi)	UTS for Exposed Specimen (ksi)	UTS Ratio of Exposed to Averaged Baseline Value	Evaluation Performed	Passed or Failed
E5	0	0	215	NA	N/A	Metallography	Passed
E6	0	0	215	222	1.033	Tensile Test	Passed
E45	0	0	215	223	1.037	Tensile Test	Passed
E46	0	0	215	223	1.037	Tensile Test	Passed
			Averages→	<b>223</b>	<b>1.036</b>		
E25	25	45.8	215	NA	NA	Metallography	Passed
E26	25	45.8	215	225	1.047	Tensile Test	Passed
E36	25	45.8	215	221	1.028	Tensile Test	Passed
E37	25	45.8	215	221	1.028	Tensile Test	Passed
			Averages→	<b>222</b>	<b>1.034</b>		
E12	50	91.5	215	NA	NA	Metallography	Passed
E13	50	91.5	215	221	1.028	Tensile Test	Passed
E63	50	91.5	215	217	1.009	Tensile Test	Passed
E64	50	91.5	215	217	1.009	Tensile Test	Passed
			Averages→	<b>218</b>	<b>1.015</b>		
E66	75	137.3	215	NA	NA	Metallography	Passed
E67	75	137.3	215	221	1.028	Tensile Test	Passed
E47	75	137.3	215	222	1.033	Tensile Test	Passed
E48	75	137.3	215	221	1.028	Tensile Test	Passed
			Averages→	<b>221</b>	<b>1.030</b>		
E55	90	164.7	215	NA	NA	Metallography	Passed
E56	90	164.7	215	222	1.033	Tensile Test	Passed
E69	90	164.7	215	223	1.037	Tensile Test	Passed
E70	90	164.7	215	217	1.009	Tensile Test	Passed
			Averages→	<b>221</b>	<b>1.026</b>		

\* In the 3.5% NaCl alternate immersion method the specimens are exposed to wet and dry cycles. For every hour, the specimens are immersed for 10 min in the salt solution, followed by a 50-min drying cycle in air at  $80 \pm 2^\circ\text{F}$  at  $45 \pm 10\%$  relative humidity. All specimens passed because no stress corrosion features were detected with metallography and no reduction in load carting ability occurred.

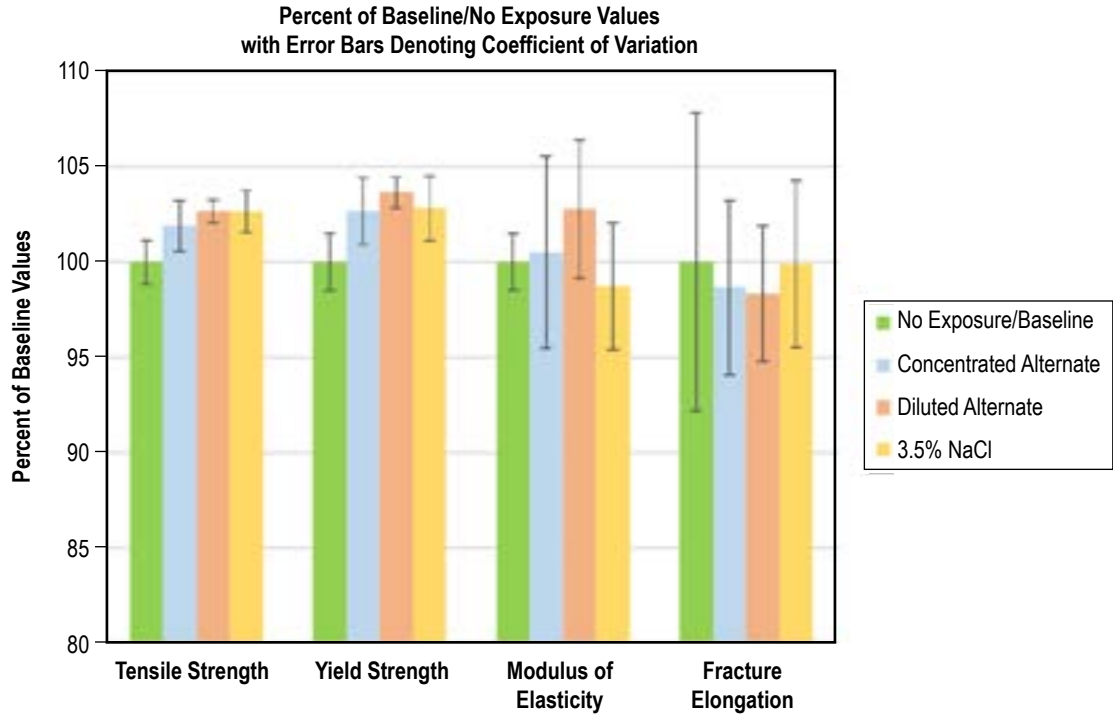

Figure 16. Graphical representation comparing baseline and post-exposure tensile data values.

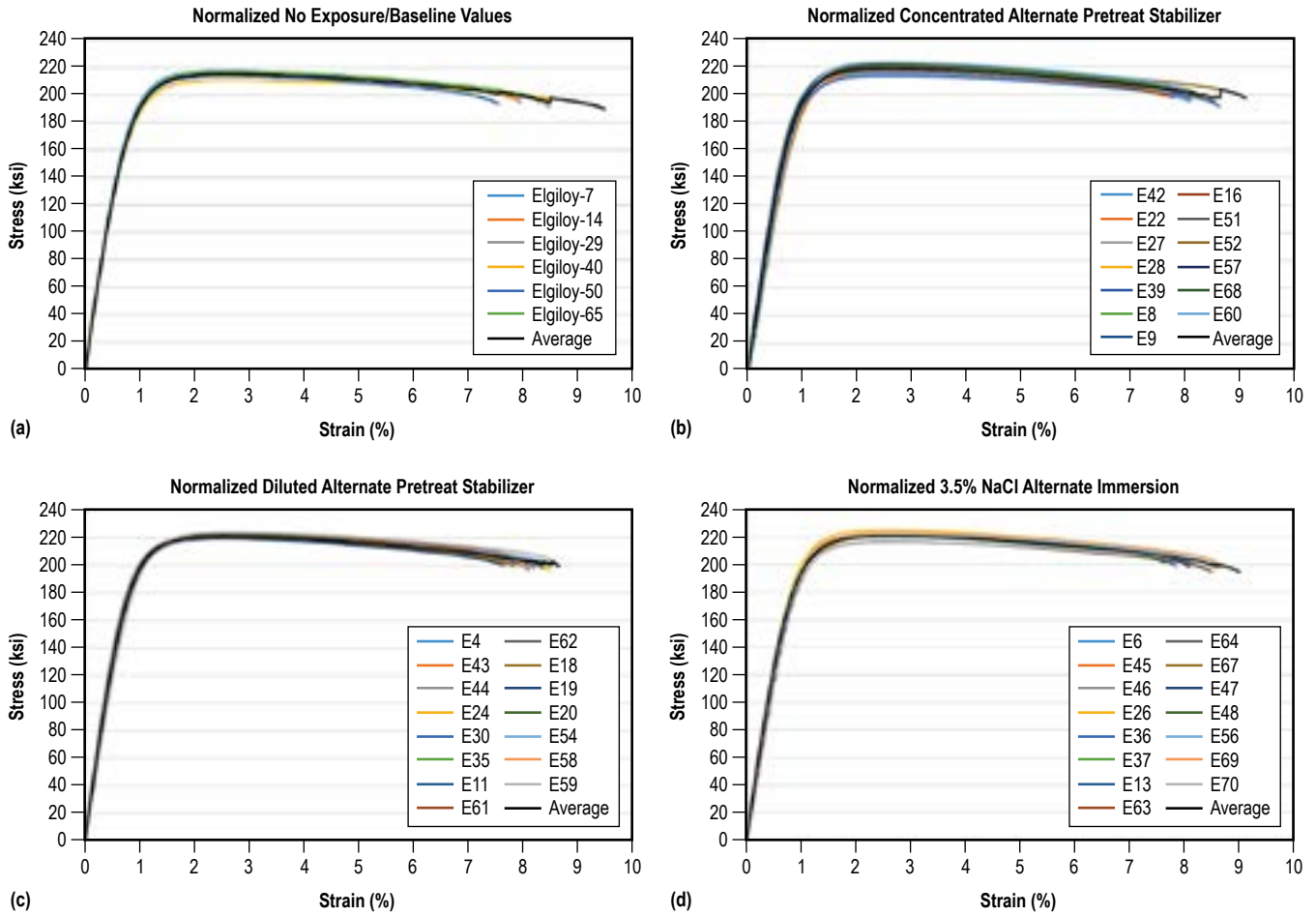

Figure 17. Stress-strain curves for normalized values for nonexposed and exposed specimens: (a) Normalized no exposure/baseline values, (b) normalized concentrated alternate pretreat stabilizer, (c) normalized diluted alternate pretreat stabilizer, and (d) normalized 3.5% NaCl alternate immersion.

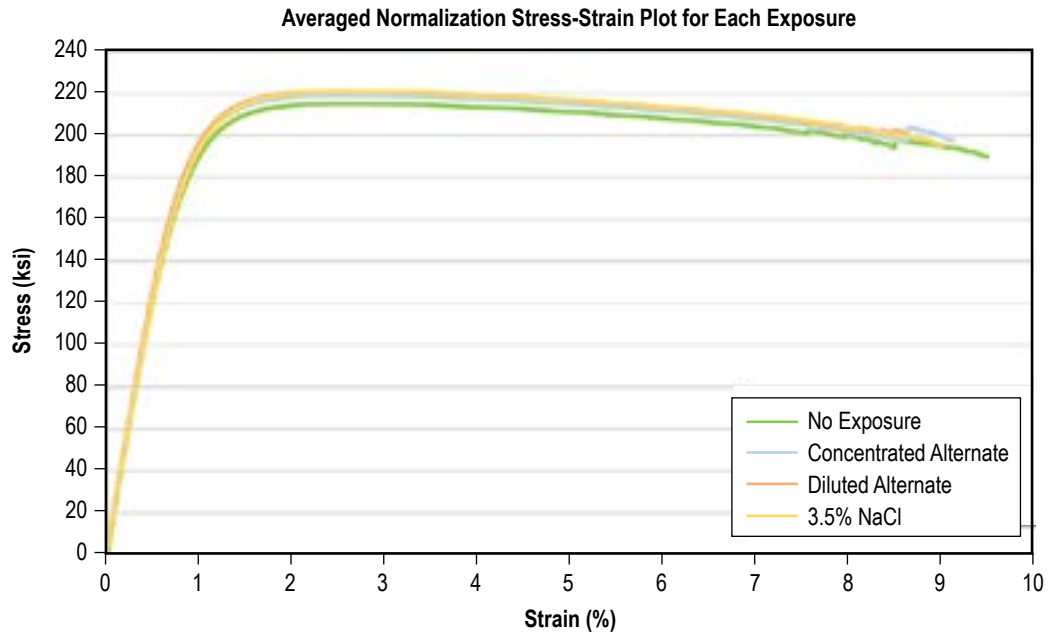

Figure 18. Stress-strain curves for averages of normalized values.

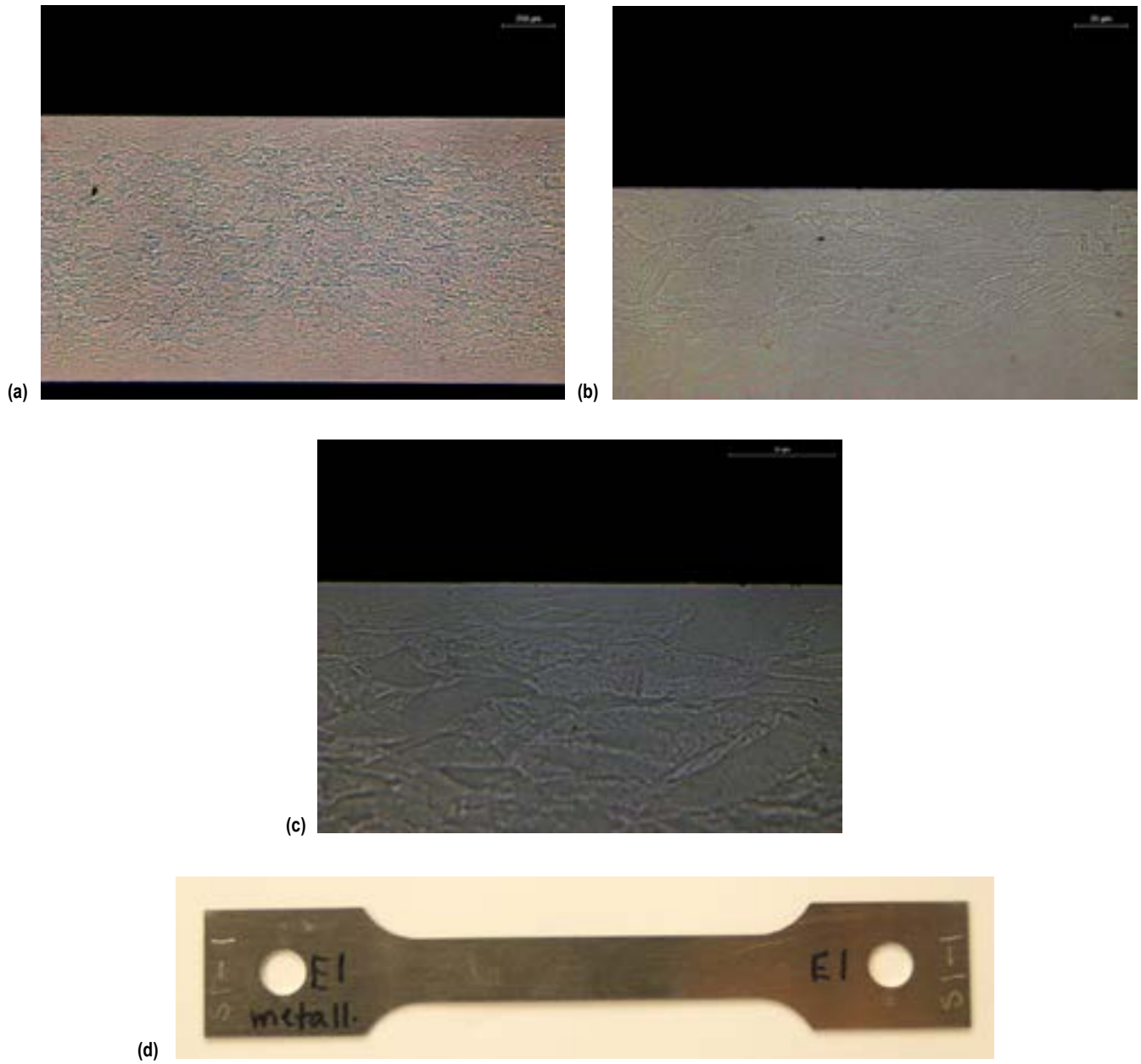

Figure 19. Metallographic and overall views of Elgiloy specimen No. E1, exposed unstressed to concentrated alternate pretreat stabilizer for 365 days: (a)  $\times 50$ , unetched, (b)  $\times 500$ , unetched, (c)  $\times 1,000$ , unetched, and (d)  $\times 1$ .

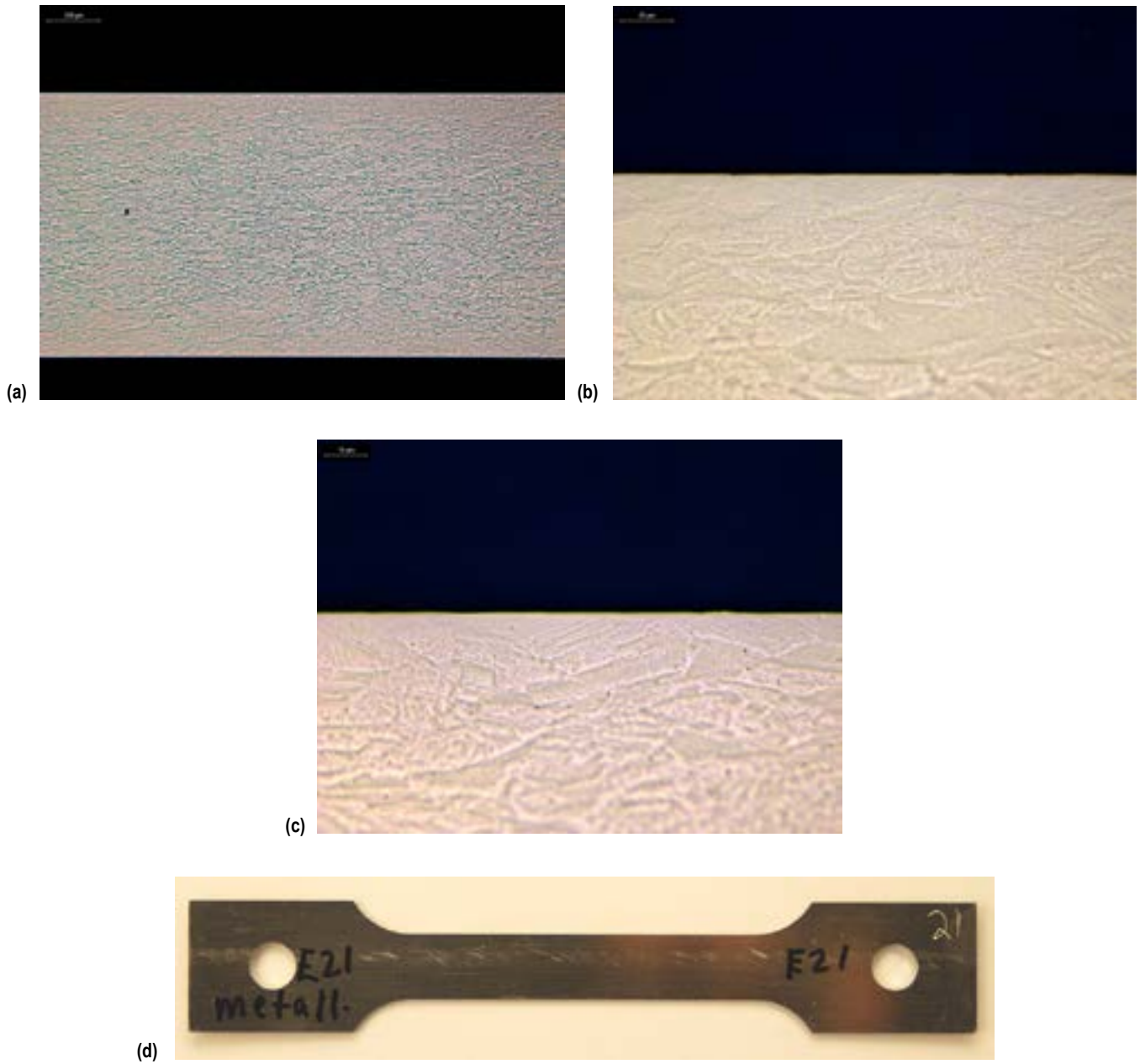

Figure 20. Metallographic and overall views of Elgiloy specimen No. E21, stressed to 25% YS (45.8 ksi), and exposed to concentrated alternate pretreat stabilizer for 365 days: (a)  $\times 50$ , unetched, (b)  $\times 500$ , unetched, (c)  $\times 1,000$ , unetched, and (d)  $\times 1$ .



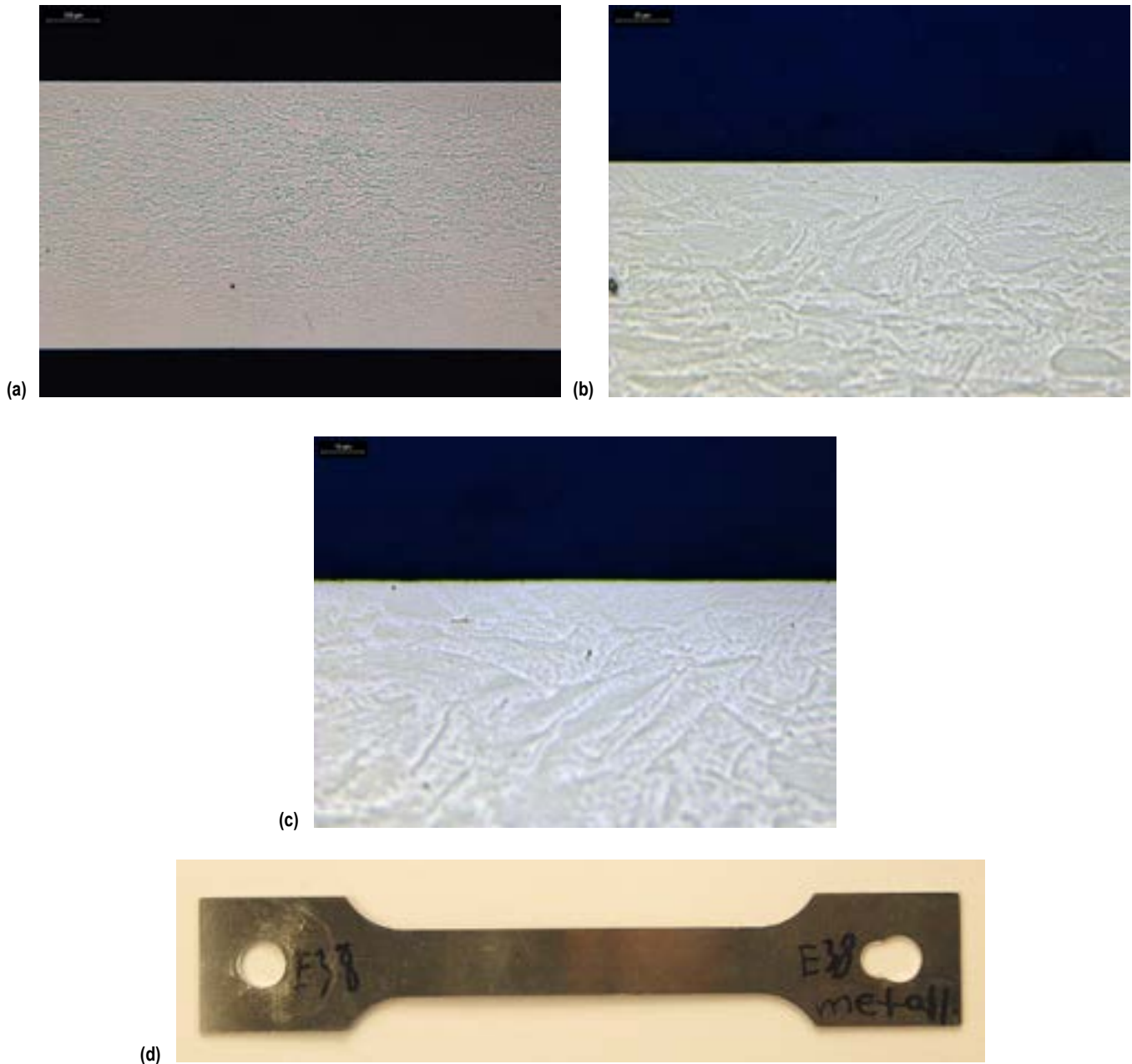

Figure 21. Metallographic and overall views of Elgiloy specimen No. E38, stressed to 50% YS (91.5 ksi), and exposed to concentrated alternate pretreat stabilizer for 365 days: (a)  $\times 50$ , unetched, (b)  $\times 500$ , unetched, (c)  $\times 1,000$ , unetched, and (d)  $\times 1$ .

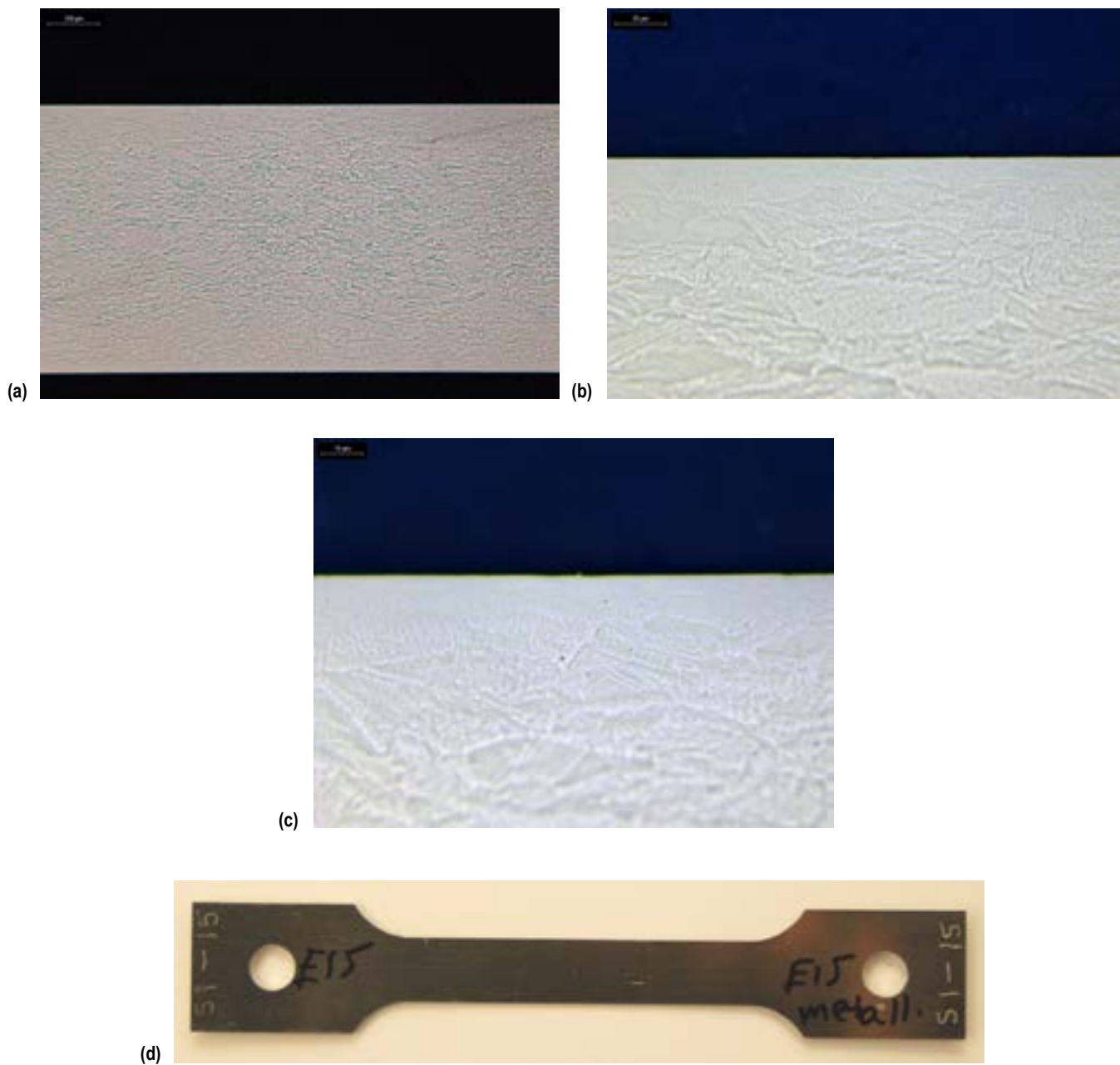

Figure 22. Metallographic and overall views of Elgiloy specimen No. E15, stressed to 75% YS (137.3 ksi), and exposed to concentrated alternate pretreat stabilizer for 365 days: (a)  $\times 50$ , unetched, (b)  $\times 500$ , unetched, (c)  $\times 1,000$ , unetched, and (d)  $\times 1$ .

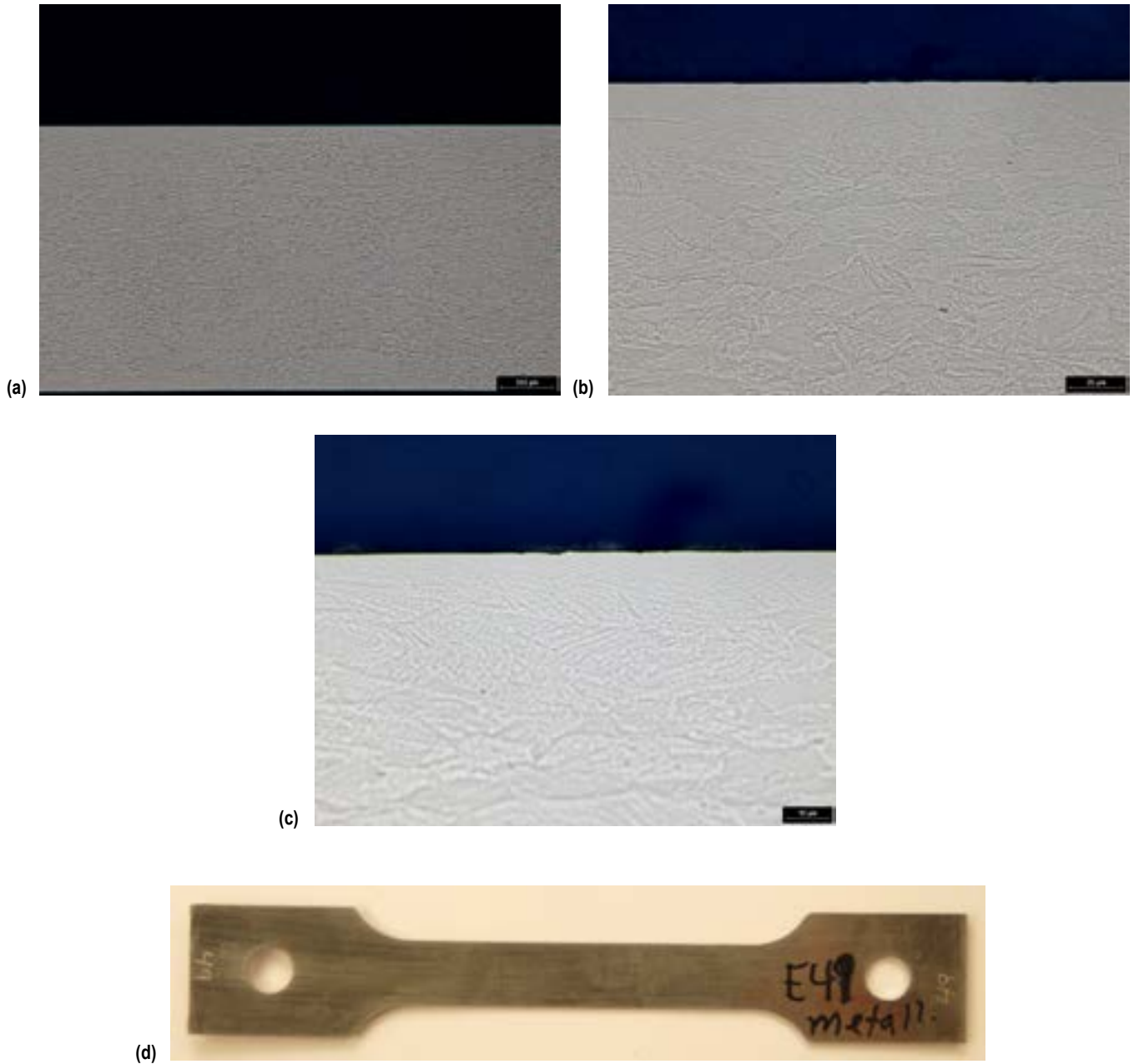

Figure 23. Metallographic and overall views of Elgiloy specimen No. E49, stressed to 90% YS (164.7 ksi), and exposed to concentrated alternate pretreat stabilizer for 365 days: (a)  $\times 50$ , unetched, (b)  $\times 500$ , unetched, (c)  $\times 1,000$ , unetched, and (d)  $\times 1$ .

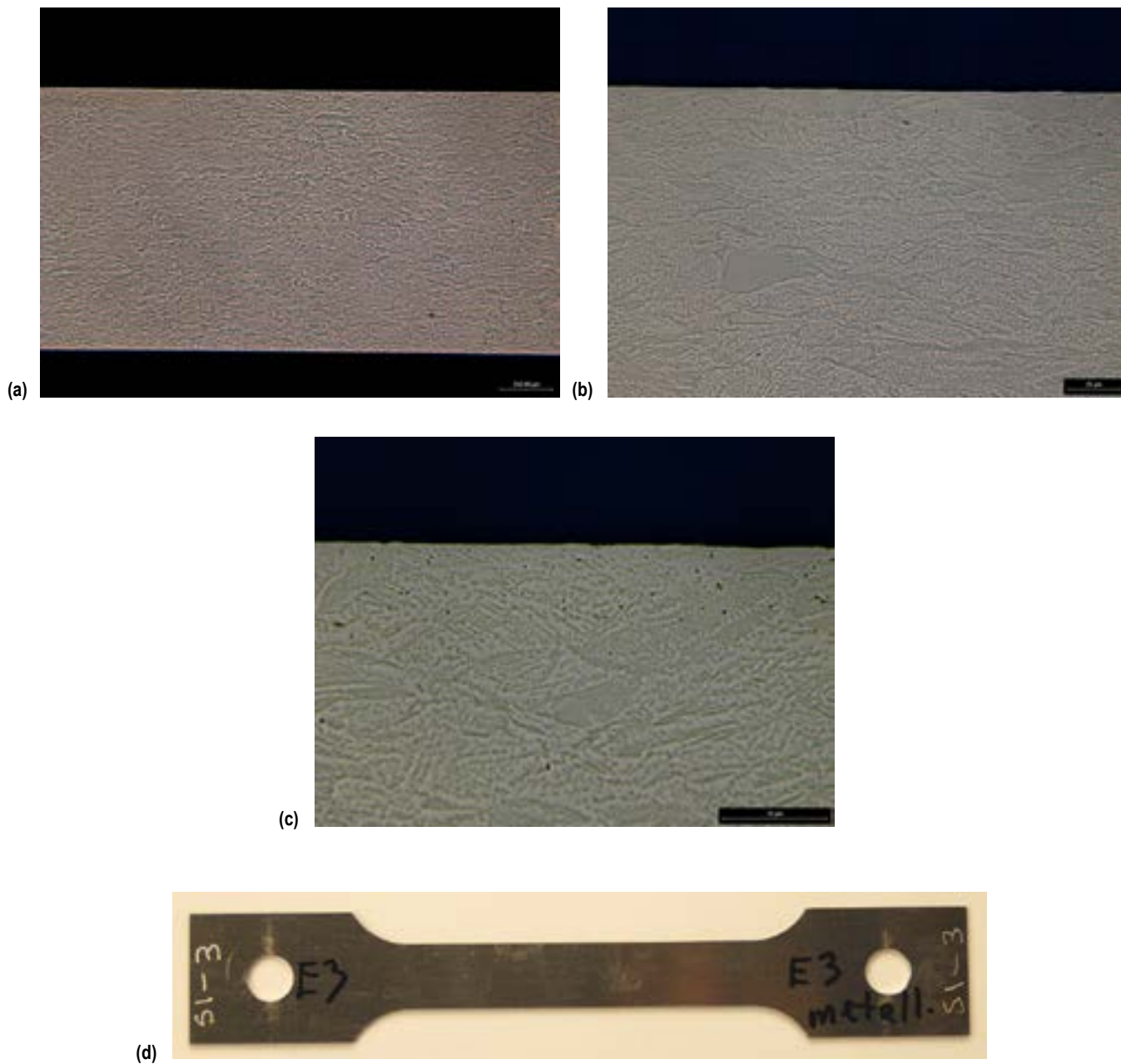

Figure 24. Metallographic and overall views of Elgiloy specimen No. E3, exposed unstressed to diluted alternate pretreat stabilizer for 365 days: (a)  $\times 50$ , unetched, (b)  $\times 500$ , unetched, (c)  $\times 1,000$ , unetched, and (d)  $\times 1$ .

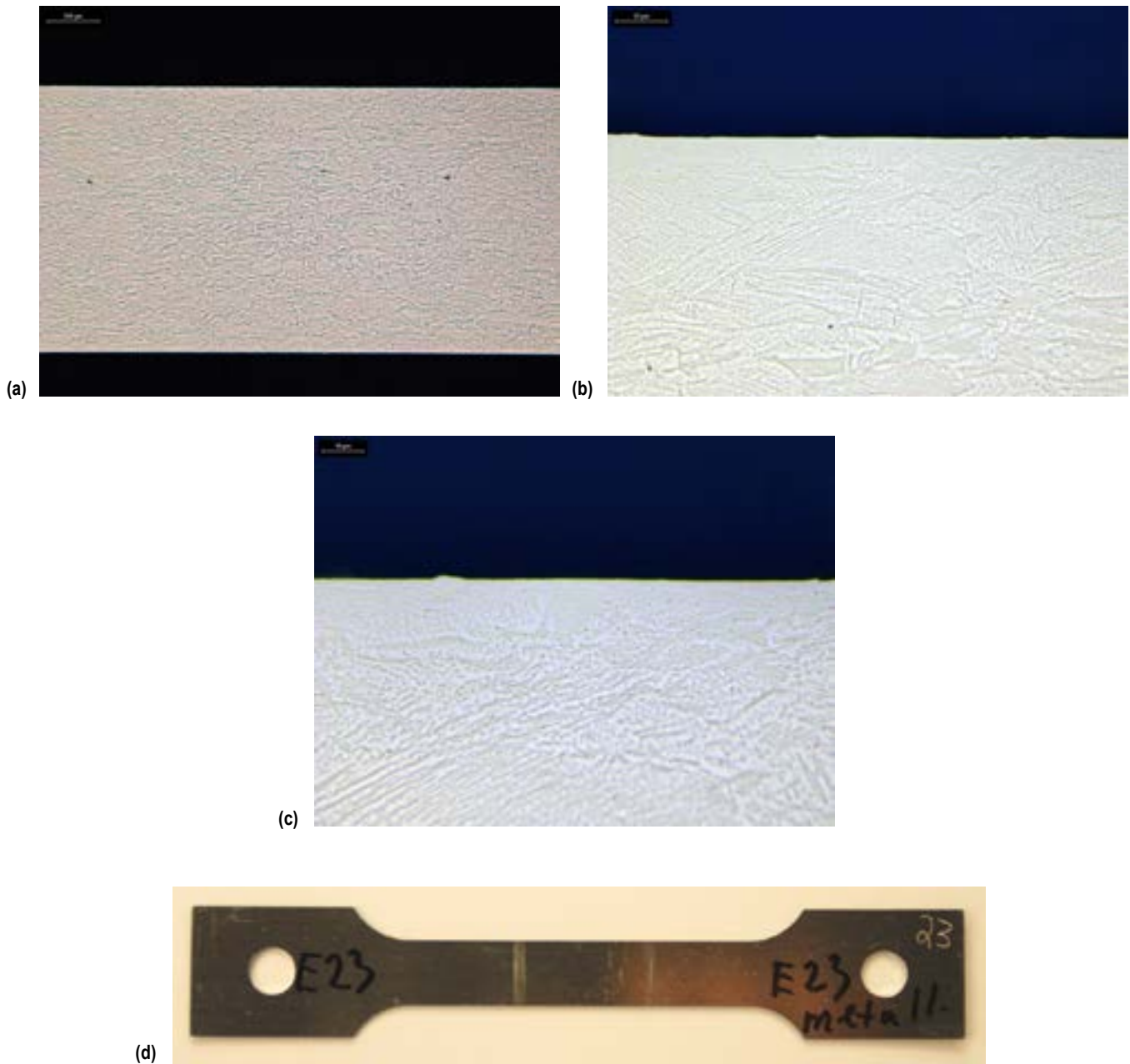

Figure 25. Metallographic and overall views of Elgiloy specimen No. E23, stressed to 25% YS (45.8 ksi), and exposed to diluted alternate pretreat stabilizer for 365 days: (a)  $\times 50$ , unetched, (b)  $\times 500$ , unetched, (c)  $\times 1,000$ , unetched, and (d)  $\times 1$ .



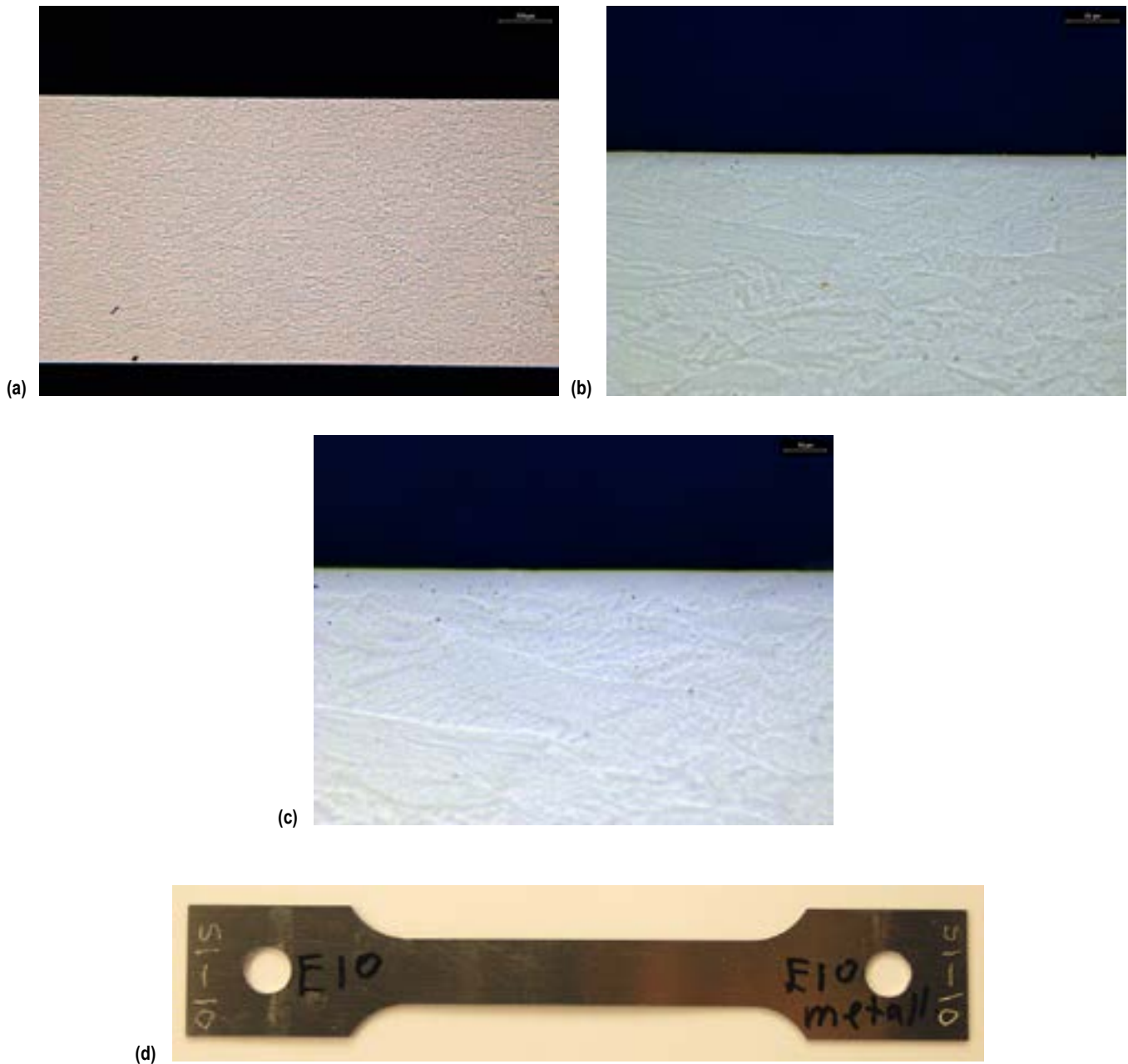

Figure 26. Metallographic and overall views of Elgiloy specimen No. E10, stressed to 50% YS (91.5 ksi), and exposed to diluted alternate pretreat stabilizer for 365 days: (a)  $\times 50$ , unetched, (b)  $\times 500$ , unetched, (c)  $\times 1,000$ , unetched, and (d)  $\times 1$ .

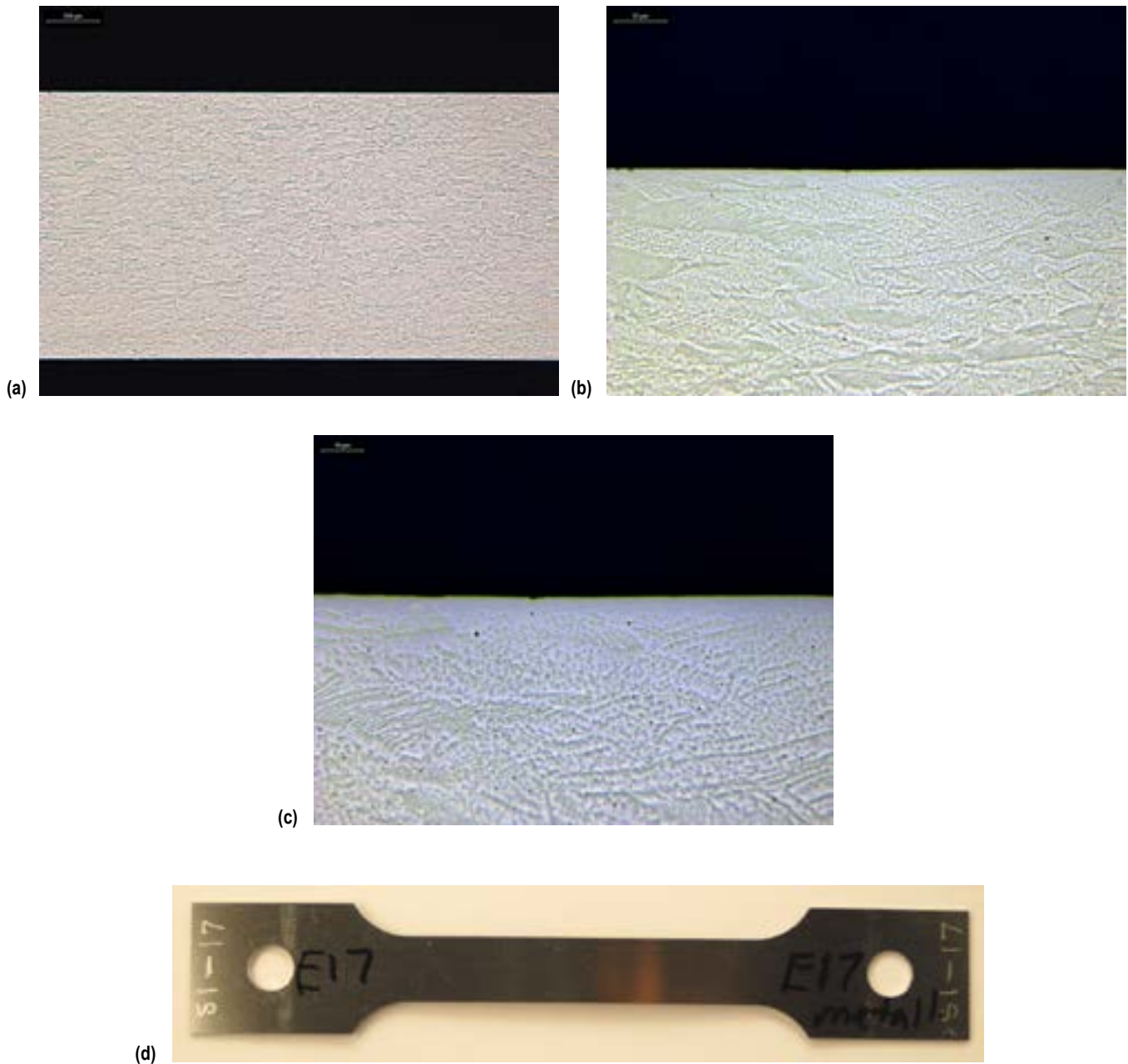

Figure 27. Metallographic and overall views of Elgiloy specimen No. E17, stressed to 75% YS (137.3 ksi), and exposed to diluted alternate pretreat stabilizer for 365 days: (a)  $\times 50$ , unetched, (b)  $\times 500$ , unetched, (c)  $\times 1,000$ , unetched, and (d)  $\times 1$ .

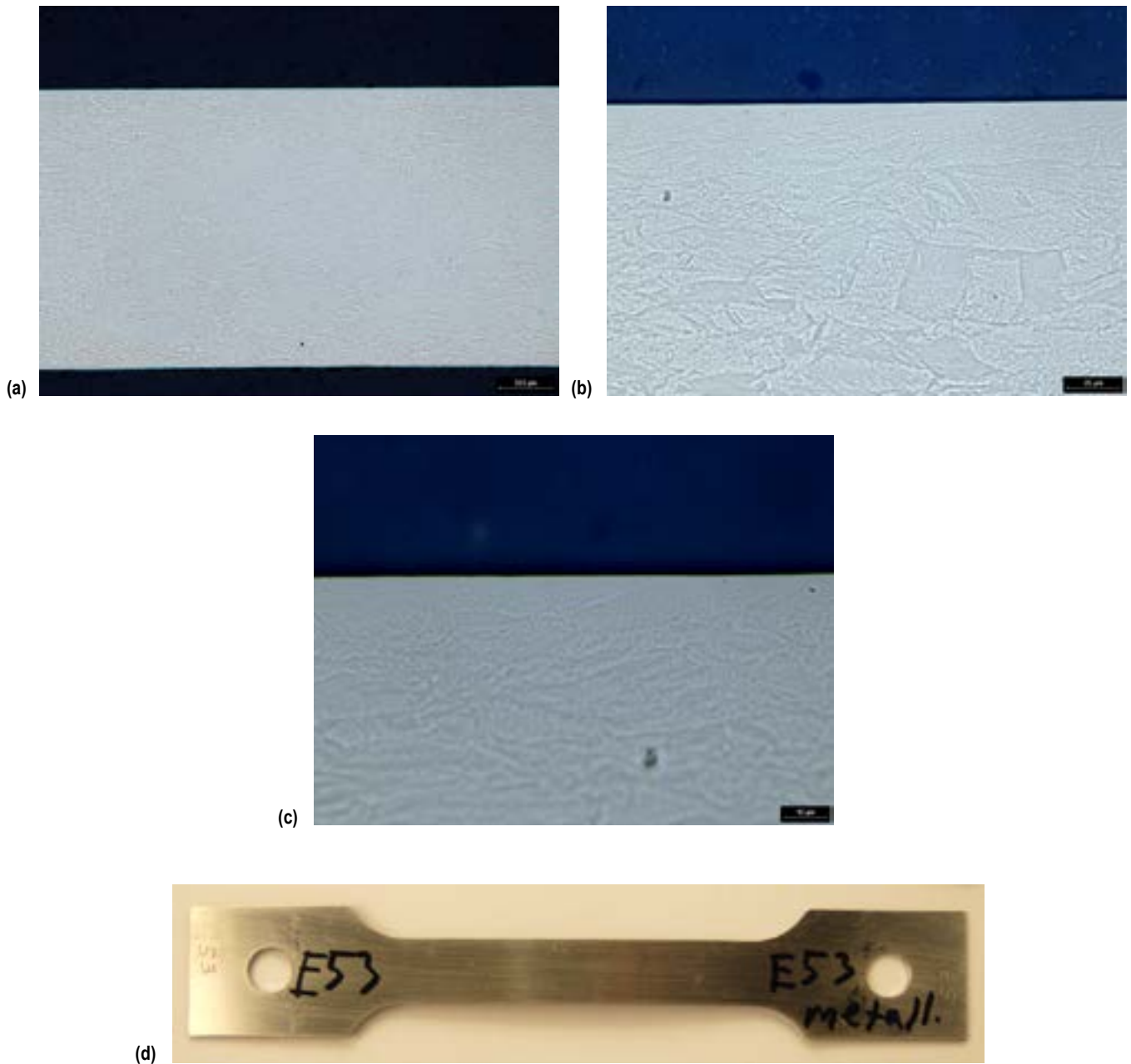

Figure 28. Metallographic and overall views of Elgiloy specimen No. E53, stressed to 90% YS (164.7 ksi), and exposed to diluted alternate pretreat stabilizer 365 days: (a)  $\times 50$ , unetched, (b)  $\times 500$ , unetched, (c)  $\times 1,000$ , unetched, and (d)  $\times 1$ .



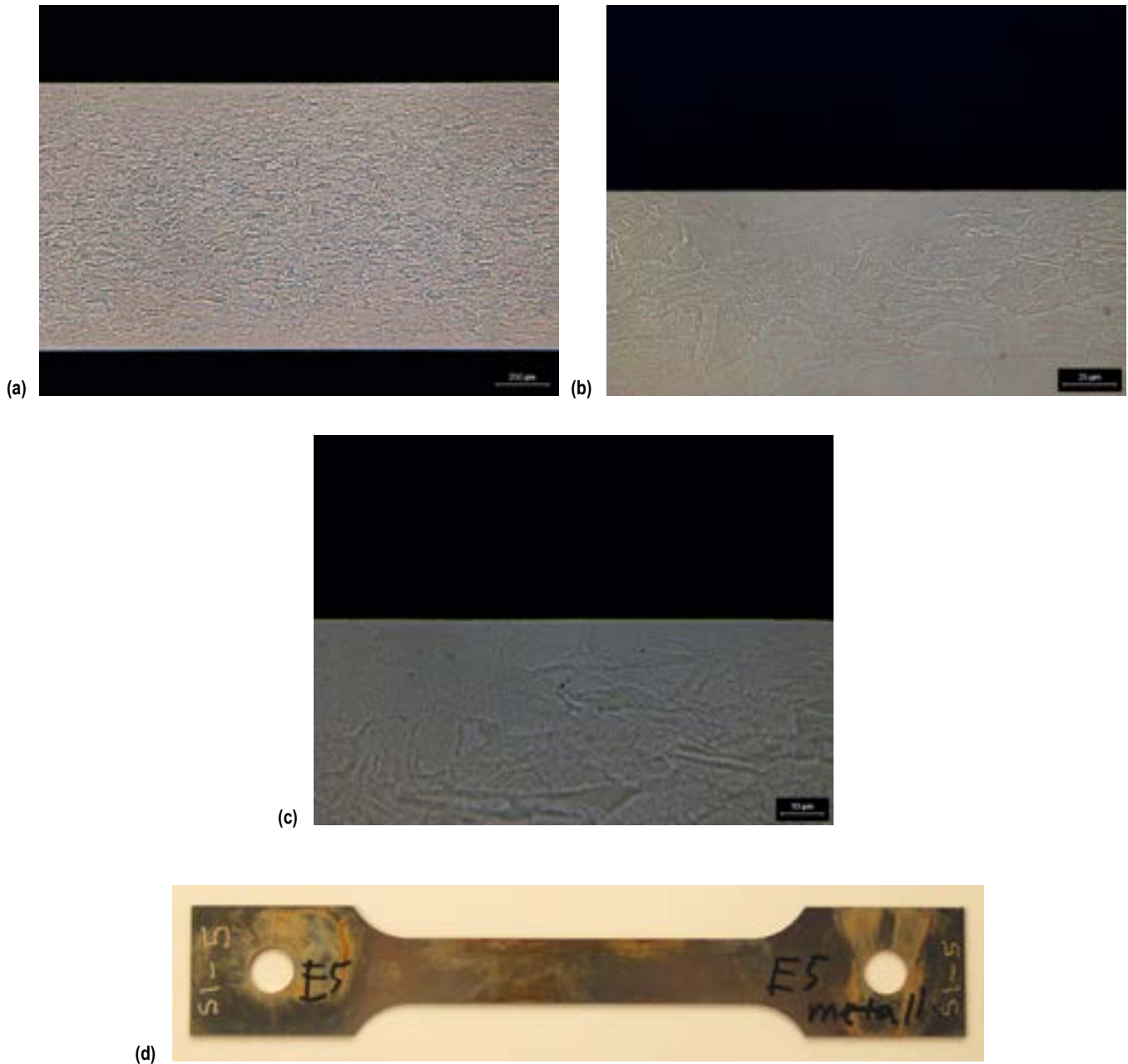

Figure 29. Metallographic and overall views of Elgiloy specimen No. E5, exposed unstressed to 3.5% NaCl alternate immersion for 365 days: (a)  $\times 50$ , unetched, (b)  $\times 500$ , unetched, (c)  $\times 1,000$ , unetched, and (d)  $\times 1$ .

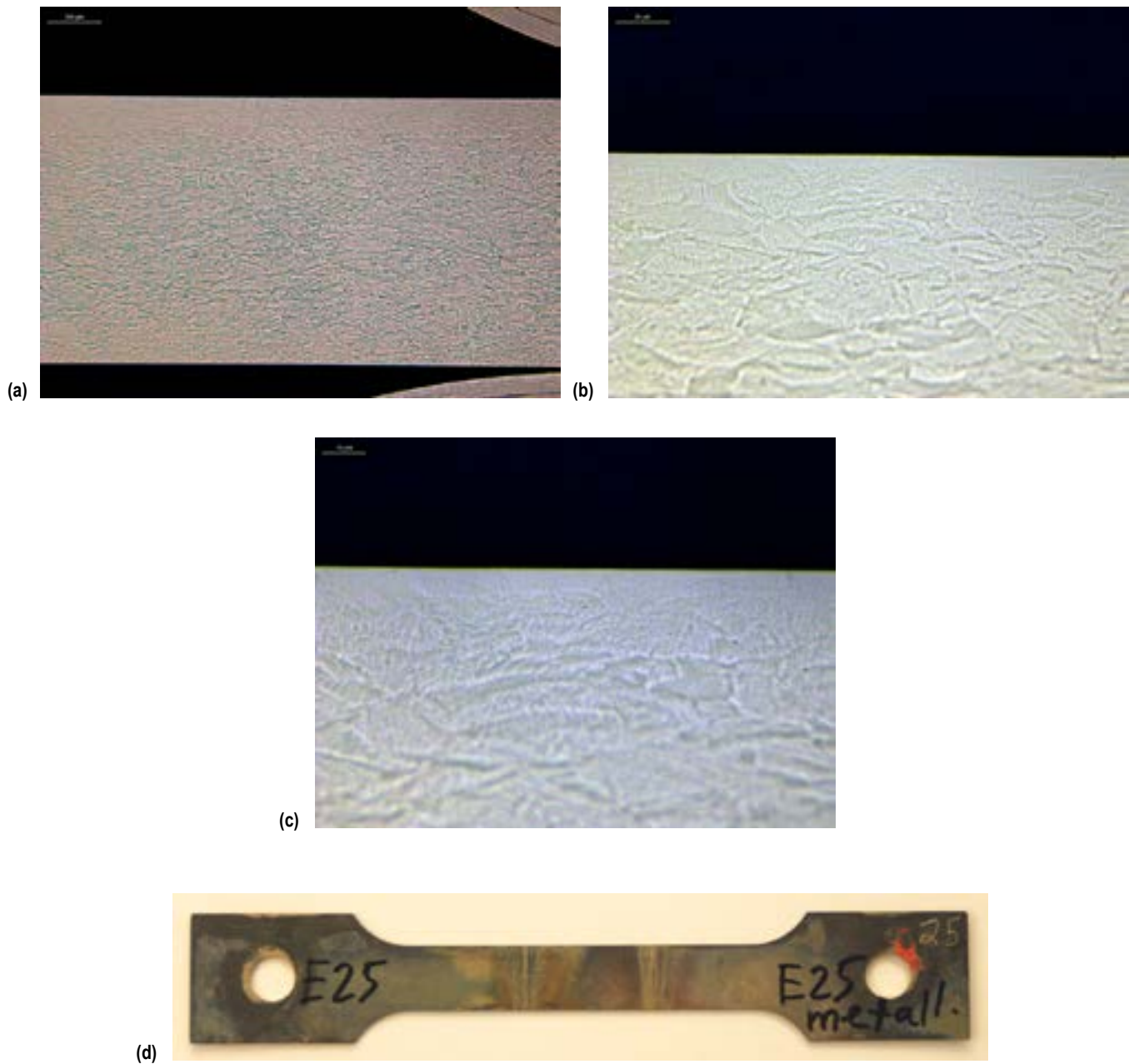

Figure 30. Metallographic and overall views of Elgiloy specimen No. E25, stressed to 25% YS (45.8 ksi) and exposed to 3.5% NaCl alternate immersion for 365 days: (a)  $\times 50$ , unetched, (b)  $\times 500$ , unetched, (c)  $\times 1,000$ , unetched, and (d)  $\times 1$ .

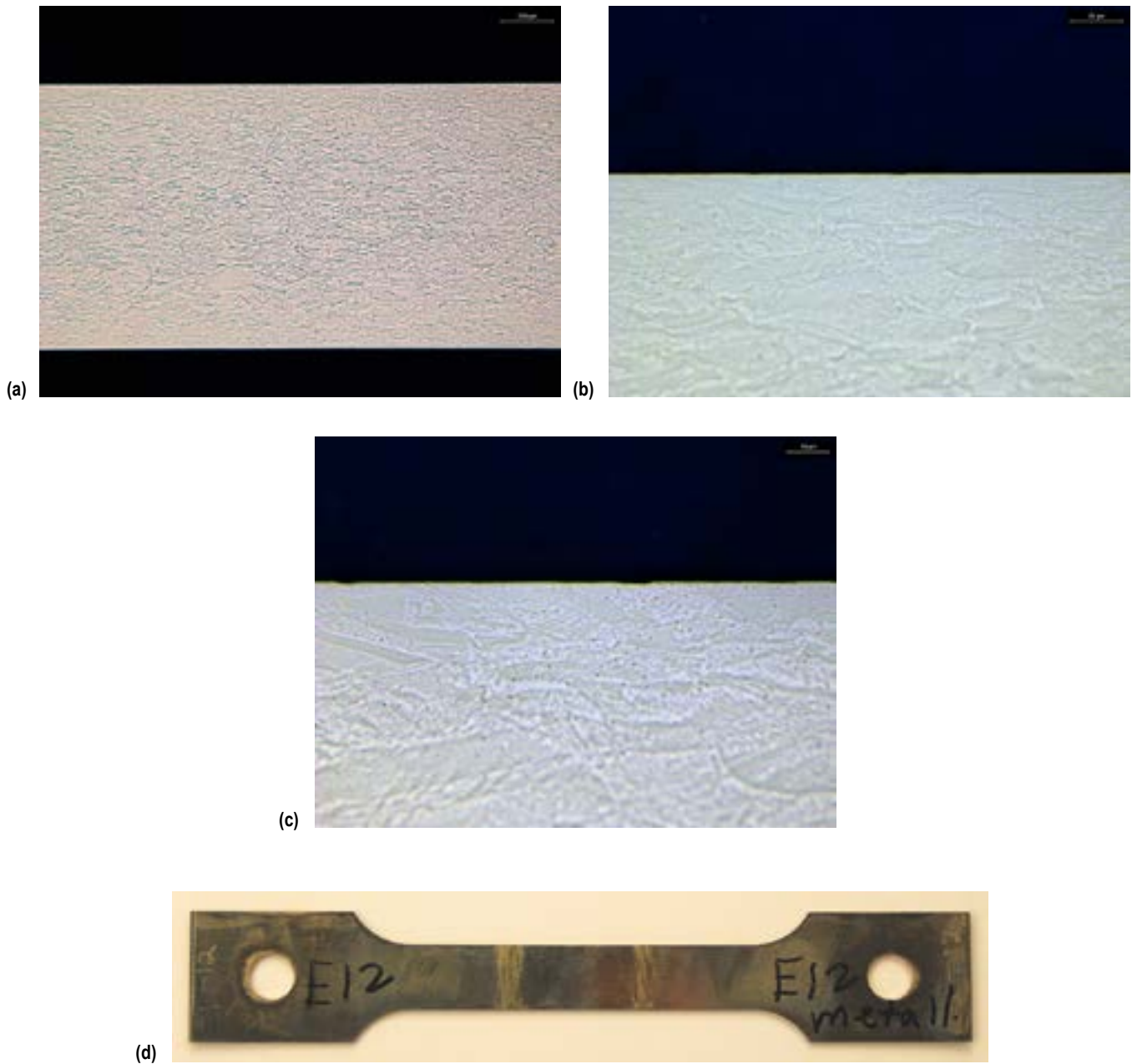

Figure 31. Metallographic and overall views of Elgiloy specimen No. E12, stressed to 50% YS (91.5 ksi) and exposed to 3.5% NaCl alternate immersion for 365 days: (a)  $\times 50$ , unetched, (b)  $\times 500$ , unetched, (c)  $\times 1,000$ , unetched, and (d)  $\times 1$ .

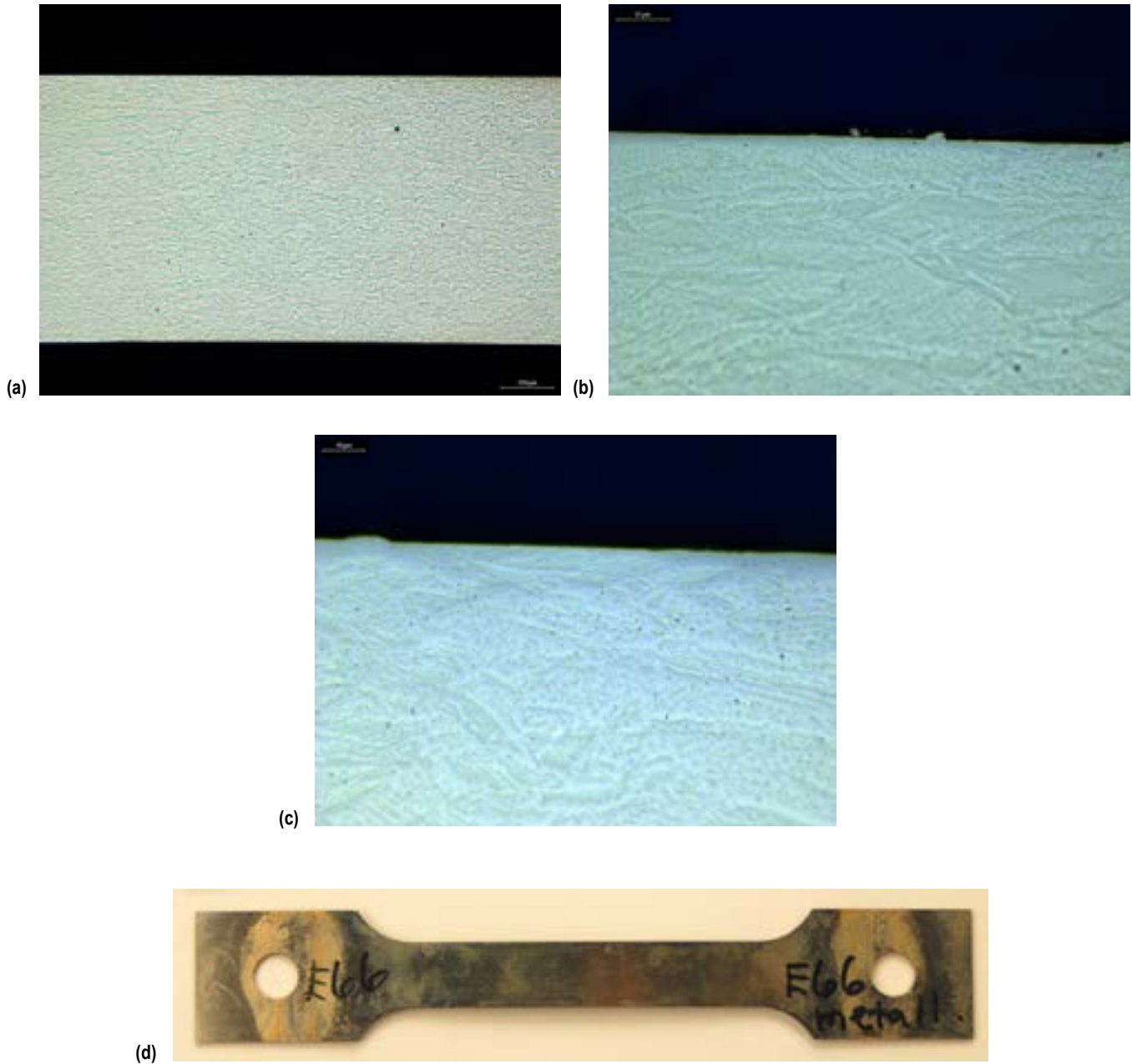

Figure 32. Metallographic and overall views of Elgiloy specimen No. E66, stressed to 75% YS (137.3 ksi) and exposed to 3.5% NaCl alternate immersion for 365 days: (a)  $\times 50$ , unetched, (b)  $\times 500$ , unetched, (c)  $\times 1,000$ , unetched, and (d)  $\times 1$ .

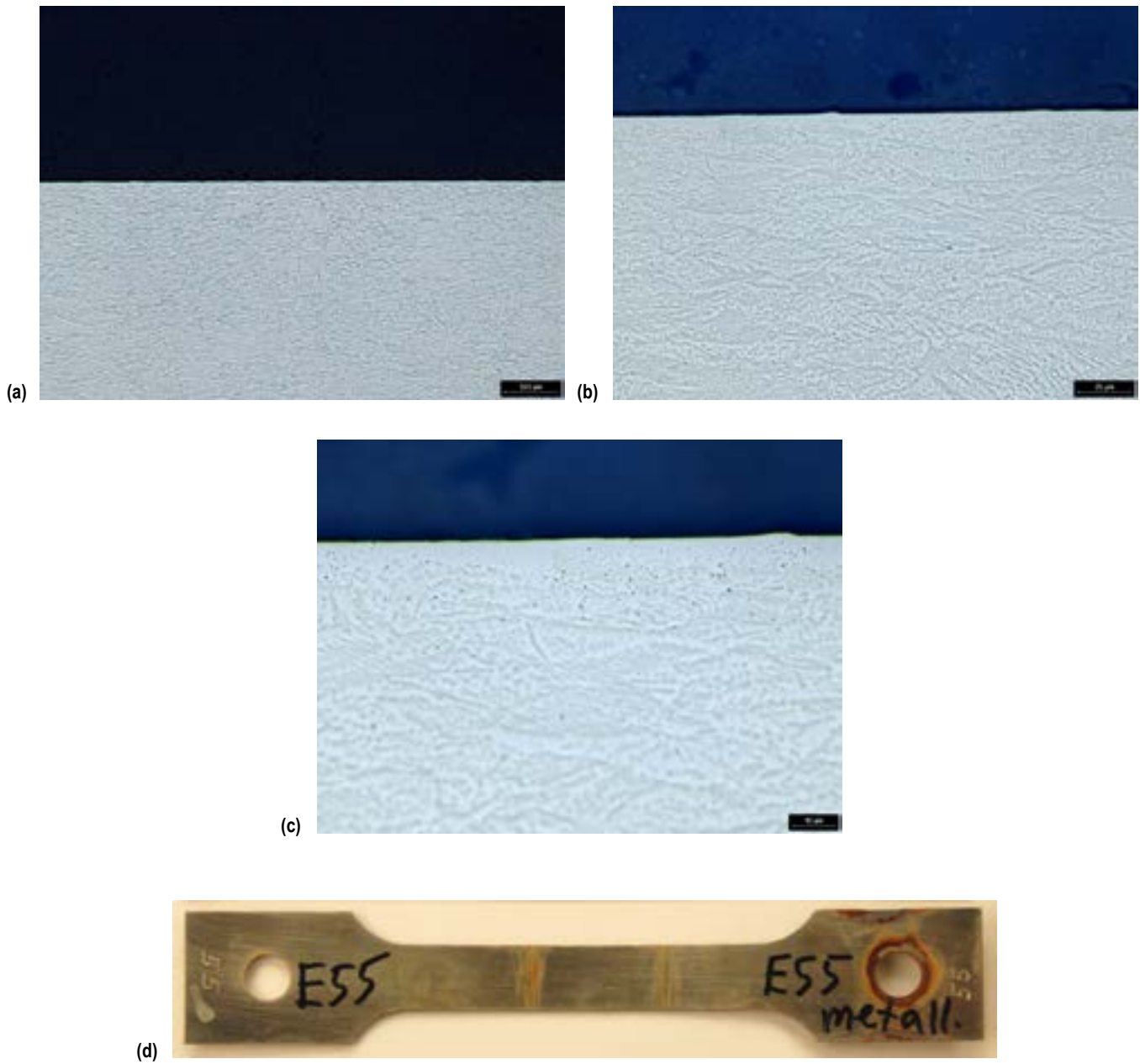

Figure 33. Metallographic and overall views of Elgiloy specimen No. E55, stressed to 90% YS (164.7 ksi) and exposed to 3.5% NaCl alternate immersion for 365 days: (a)  $\times 50$ , unetched, (b)  $\times 500$ , unetched, (c)  $\times 1,000$ , unetched, and (d)  $\times 1$ .

#### **4. CONCLUSIONS**

Bent-beam stress corrosion specimens of 0.05-in sheet Elgiloy alloy survived a year-long exposure to concentrated alternate pretreat stabilizer, diluted pretreat stabilizer, and 3.5% NaCl alternate immersion. No reduction in tensile strength resulted from exposure, and metallography showed no indications of stress corrosion on any of the specimens evaluated at stress levels of up to 90% YS. These results indicate that this material, at the strength level tested (215 ksi UTS), is resistant to stress corrosion cracking in the three environments in which it was tested.



## APPENDIX A—CERTIFICATE OF CONFORMANCE FOR ELGILOY

Figure 34 is the certificate of conformance from Elgiloy Specialty Metals referenced in section 2.

	<b>ELGILOY SPECIALTY METALS DIVISION</b> 1565 FLEETWOOD DRIVE ELGIN, IL 60123 Phone: (847)695-1900 Fax: (847)695-0189 <a href="http://www.elgloy.com">http://www.elgloy.com</a>
<b>CERTIFICATE OF CONFORMANCE</b>	
Date:	01-25-17
Customer:	AERIE AEROSPACE, LLC
Lot Number:	306422
ESM Order Number:	192100
Customer Order Number:	P29654
Quantity ( LBS ):	5
Part Number:	Cust Part #ELGI.050
Heat Number:	L2066
Specification(s):	AMS 5876 Rev# D
Description:	ELGILOY TR3 SPRING COIL Gauge: .050+/- .003 (047/.053) Width: 11.000+/.062/- .25
<p>We hereby certify that the above mentioned parts have been manufactured and inspected to all the requirements of the documents, specifications and the contract/order current at the time of manufacture and fully comply to these requirements.</p>	
Approved by:	 RICHARD OMOTEK, QUALITY MANAGER

Figure 34. Certificate of conformance for Elgiloy.

## APPENDIX B—INSPECTION CERTIFICATE FOR ELGILOY

Figure 35 is the inspection certificate obtained from Elgiloy Specialty Metals referenced in section 2.

<b>ELGILOY SPECIALTY METALS</b> 1585 FLEETWOOD DRIVE ELGIN, IL 60120 Phone: (847)895-1900 Fax: (847)895-0188 http://www.elgiloy.com		WORK ORDER NO. NO D'ORDRE COM. NR		LOT CODE	Page No.																																																									
		192100		306432	1 of 2																																																									
Material Testing Performed by Elgiloy Specialty Metals 1585 Fleetwood Drive Elgin, Illinois 60120		<b>INSPECTION CERTIFICATE / CERTIFICAT DE RECEPTION / ABNAHMEPRUFZEUGNIS</b> EN 10204:2004 - 3.1																																																												
CUSTOMER / CLIENT / BESTELLER AERIS AEROSPACE, LLC 306 VOYAGER WAY SUITE 200 HUNTSVILLE, AL 35898		PRODUCT / PRODUIT / PRODUKT ELGILOY TR3 SPRING COIL Gauge: .090+/- .002(647: 603) Width: 11.505-052-25 Cust.Part: ELGI-090 Alpha Case Result: 0		SPECIFICATION / SPECIFICATION / SPEZIFIKATION AMS 5675 Rev# 2																																																										
CUSTOMER REFERENCE COMMANDE NO. AUFTRAGS - NR	QUANTITY SHIPPED QUANTITE LBS	HEAT NUMBER NUMERO DE COULEE CHARGES - NR	MILL SOURCE MOULIN MÜHLE	ORIGIN COUNTRY ORIGINE URSPRUNG																																																										
P2964	8	L2086	APERAM ALLOYS USA, INC.	FRANCE																																																										
CHEMICAL ANALYSIS % PULLED FROM ORIGINAL MILL CERTIFICATION / ANALYSE CHIMIQUE / CHEMISCHE ANALYSE																																																														
<table border="1" style="width: 100%; border-collapse: collapse;"> <tr> <td>C</td><td>Mn</td><td>P</td><td>S</td><td>Si</td><td>Cr</td><td>Ni</td><td>Mo</td><td>Cu</td><td>Ti</td><td>Al</td><td>Fe</td><td>N</td><td>Co</td> </tr> <tr> <td>0.04</td><td>1.81</td><td>0.009</td><td>0.001</td><td>0.4</td><td>19.4</td><td>15.8</td><td>2.1</td><td>0.045</td><td>0.02</td><td>0.21</td><td>15.8</td><td>0.02</td><td>35.6</td> </tr> <tr> <td colspan="6"></td> <td>Ta</td><td>V</td><td>B</td><td>Cb</td><td>W</td><td>Ag</td><td>Bi</td><td>Ni+Co</td> </tr> <tr> <td colspan="6"></td> <td>+0.002</td><td>0.1</td><td>+0.0005</td><td>0.1</td><td>+0.0001</td><td>+0.004</td><td>+0.0005</td><td>+0.0001</td><td>55.1</td> </tr> </table>						C	Mn	P	S	Si	Cr	Ni	Mo	Cu	Ti	Al	Fe	N	Co	0.04	1.81	0.009	0.001	0.4	19.4	15.8	2.1	0.045	0.02	0.21	15.8	0.02	35.6							Ta	V	B	Cb	W	Ag	Bi	Ni+Co							+0.002	0.1	+0.0005	0.1	+0.0001	+0.004	+0.0005	+0.0001	55.1
C	Mn	P	S	Si	Cr	Ni	Mo	Cu	Ti	Al	Fe	N	Co																																																	
0.04	1.81	0.009	0.001	0.4	19.4	15.8	2.1	0.045	0.02	0.21	15.8	0.02	35.6																																																	
						Ta	V	B	Cb	W	Ag	Bi	Ni+Co																																																	
						+0.002	0.1	+0.0005	0.1	+0.0001	+0.004	+0.0005	+0.0001	55.1																																																
Physical Properties at RT / Propriétés Physiques à Temp. Ambiente / Physikalische Eigenschaften bei RT																																																														
Tensile Res. à la Trac. Zugfestigkeit PSI ASTM E8		0.2% Yield Strength Limit Elong. à 0.2% 0.2% Streckgrenze PSI ASTM E8		Elong. Along Déformation % SRA, ASTM E8		Grain Size Grain de Grain Korngrösse ASTM E112		Hardness Dureté Härte ASTM E384 E18		Agpt / Verfahren / Gerät																																																				
T 220000		18400		8						Condition																																																				
T L										(As Supplied)																																																				
T 256000		23800		4				40 HRC		800F ± 25.0.25HRS ± 25AC																																																				
Tensile Test at Elevated Temp - Essai de Traction à Hs. Temp. Warm Zugversuch																																																														
Test Essai Versuch Temp. F		Tensile Res. à la Trac. Zugfestigkeit PSI		0.2% Yield Strength Limit Elong. à 0.2% 0.2% Streckgrenze PSI		Elong. Along Déformation %		Stress Rpt. / Essai de Traction / Zugsversuch Test Essai Versuch Temp. F																																																						
								Stress Contrainte Spannung PSI																																																						
								Hours Heures Stunden																																																						
								Elong. Along Déformation %																																																						
WIPAP TEST / ESSAI DE PLIAGE / WICKELTEST		BEND TEST / ESSAI D'ENROULEMENT / BIEGETEST		GA		IGO		MICROSTRUCTURE																																																						
Testing Source																																																														
Shift Type																																																														
R/Factor																																																														
Continue on the next page																																																														
THIS DOCUMENT SHALL NOT BE REPRODUCED, EXCEPT IN FULL, WITHOUT THE WRITTEN APPROVAL OF ELGILOY SPECIALTY METALS. THE RECORDING OF FALSE, FICTITIOUS OR FRAUDULENT STATEMENTS OF ENTRIES ON THIS DOCUMENT MAY BE A PUNISHABLE OFFENSE UNDER FEDERAL AND STATE LAW																																																														

Figure 35. Inspection certificate for Elgiloy.



## APPENDIX C—TENSILE DATA FOR ELGILOY

All tensile data values used to generate the illustrations shown in figures 16–18 are presented in table 8.

Table 8. Compiled tensile data for Elgiloy.

Exposure	Specimen ID	Tensile Stress (ksi)	Yield Stress (ksi)	Modulus of Elasticity (msi)	Fracture Elongation (%)
No Exposure/Baseline Values	Elgiloy-7	217.45	186.50	26.34	8.31
	Elgiloy-14	216.78	184.99	25.40	7.96
	Elgiloy-29	214.95	182.72	25.73	8.50
	Elgiloy-40	210.99	178.52	25.29	9.51
	Elgiloy-50	214.05	182.04	25.43	7.57
	Elgiloy-65	217.01	183.15	25.66	8.30
Concentrated Alternate Pretreat Stabilizer for 1 yr	E2	218.74	183.30	25.51	NA
	E41	223.00	184.05	25.07	NA
	E42	214.91	181.97	25.52	8.09
	E22	217.03	190.09	22.65	7.63
	E27	220.49	190.25	26.74	8.29
	E28	219.83	188.94	26.94	8.28
	E39	213.48	182.52	25.90	8.64
	E8	220.28	190.34	27.53	8.28
	E9	219.30	188.67	26.15	8.09
	E16	217.57	188.37	25.54	7.80
	E51	216.90	187.54	27.64	8.55
	E52	220.93	188.79	25.38	9.14
	E57	222.61	190.24	26.13	8.13
	E68	221.32	191.52	24.34	8.23
E60	223.60	191.43	24.58	8.07	
Diluted Alternate Pretreat Stabilizer for 1 yr	E4	220.07	189.61	26.44	8.11
	E43	220.13	188.01	26.68	8.02
	E44	220.60	190.67	28.19	8.30
	E24	220.01	187.96	26.85	8.49
	E30	221.12	189.38	26.94	8.36
	E35	220.41	189.22	27.04	8.53
	E11	221.90	192.05	26.84	7.93
	E61	223.19	188.47	26.69	8.36
	E62	219.44	186.61	27.30	8.21
	E18	220.21	190.44	25.10	7.85
	E19	219.57	190.69	25.75	7.66
	E20	222.13	192.47	25.70	8.07
	E54	220.49	190.13	25.67	8.67
	E58	220.92	188.89	25.68	8.13
E59	224.19	190.67	24.45	8.62	

Table 8. Compiled tensile data for Elgiloy (Continued).

Exposure	Specimen ID	Tensile Stress (ksi)	Yield Stress (ksi)	Modulus of Elasticity (msi)	Fracture Elongation (%)
3.5% NaCl Alternate Immersion for 1 yr	E6	222.41	190.17	25.90	8.16
	E45	222.51	189.85	26.39	8.11
	E46	222.56	189.22	26.06	8.04
	E26	225.29	191.78	26.44	8.19
	E36	220.72	186.99	26.02	8.60
	E37	220.70	186.49	25.80	8.69
	E13	220.51	189.52	25.40	7.87
	E63	216.78	183.19	25.63	8.51
	E64	216.74	181.72	25.24	8.48
	E67	220.65	185.20	23.98	8.61
	E47	221.66	192.30	23.72	8.10
	E48	220.63	189.15	25.01	7.66
	E56	221.86	189.78	25.14	8.54
	E69	223.46	191.90	24.47	8.67
E70	217.18	185.44	24.58	9.02	

## REFERENCES

1. AMS 5876: “Cobalt Alloy, Corrosion and Heat-Resistant, Strip, 20Cr - 15Ni - 40Co - 7.0Mo - 16Fe, Vacuum Induction Plus Consumable Electrode Remelted, Solution Heat Treated and Cold Rolled (Composition similar to UNS R30003),” Rev. D, June 2014.
2. Stapleton, T.J.; Baccus, S.; and Broyan, J.L.: “Development of a Universal Waste Management System,” Paper Presented at 2013 International Conference on Environmental Systems (ICES), Vail, CO, July 14–18, 2013.
3. Stapleton, T.; Converse, D; and Broyan, J.L.: “Dual Fan Separator Within the Universal Waste Management System,” Paper Presented at 44th International Conference of Environmental Systems, Tucson, AZ, July 13–17, 2014.
4. Torres, P.D.: “Stress Corrosion Evaluation of Various Metallic Materials for the International Space Station Water Recycling System,” NASA/TM—2015–218206, NASA Marshall Space Flight Center, Huntsville, AL, 66 pp., March 2015.
5. Torres, P.D.: “Stress Corrosion Evaluation of Nitinol 60 for the International Space Station Water Recycling System,” NASA/TM—2016–218230, NASA Marshall Space Flight Center, Huntsville, Alabama, 38 pp., November 2016.
6. ASTM G 39-99: “Standard Practice for Preparation and Use of Bent-Beam Stress-Corrosion Test Specimens,” ASTM International, West Conshohocken, PA, May 2016.
7. Humphries, T.S.: “Procedures for Externally Loading and Corrosion Testing Stress Corrosion Specimens,” NASA/TM—X–53483, NASA Marshall Space Flight Center, Huntsville, Alabama, 38 pp., June 29, 1966.
8. ASTM G 44-99: “Standard Practice for Exposure of Metals and Alloys by Alternate Immersion in Neutral 3.5 % Sodium Chloride Solution,” ASTM International, West Conshohocken, PA, July 2013.

REPORT DOCUMENTATION PAGE			Form Approved OMB No. 0704-0188		
<p>The public reporting burden for this collection of information is estimated to average 1 hour per response, including the time for reviewing instructions, searching existing data sources, gathering and maintaining the data needed, and completing and reviewing the collection of information. Send comments regarding this burden estimate or any other aspect of this collection of information, including suggestions for reducing this burden, to Department of Defense, Washington Headquarters Services, Directorate for Information Operation and Reports (0704-0188), 1215 Jefferson Davis Highway, Suite 1204, Arlington, VA 22202-4302. Respondents should be aware that notwithstanding any other provision of law, no person shall be subject to any penalty for failing to comply with a collection of information if it does not display a currently valid OMB control number.</p> <p><b>PLEASE DO NOT RETURN YOUR FORM TO THE ABOVE ADDRESS.</b></p>					
1. REPORT DATE (DD-MM-YYYY) 01-05-2019		2. REPORT TYPE Technical Memorandum		3. DATES COVERED (From - To)	
4. TITLE AND SUBTITLE  Stress Corrosion Evaluation of Elgiloy Alloy for the ISS ECLSS— Universal Waste Management System			5a. CONTRACT NUMBER		
			5b. GRANT NUMBER		
			5c. PROGRAM ELEMENT NUMBER		
6. AUTHOR(S)  Pablo D. Torres			5d. PROJECT NUMBER		
			5e. TASK NUMBER		
			5f. WORK UNIT NUMBER		
7. PERFORMING ORGANIZATION NAME(S) AND ADDRESS(ES) George C. Marshall Space Flight Center Huntsville, AL 35812			8. PERFORMING ORGANIZATION REPORT NUMBER  M-1484		
9. SPONSORING/MONITORING AGENCY NAME(S) AND ADDRESS(ES) National Aeronautics and Space Administration Washington, DC 20546-0001			10. SPONSORING/MONITOR'S ACRONYM(S) NASA		
			11. SPONSORING/MONITORING REPORT NUMBER NASA/TM—2019-220133		
12. DISTRIBUTION/AVAILABILITY STATEMENT Unclassified-Unlimited Subject Category 26 Availability: NASA STI Information Desk (757-864-9658)					
13. SUPPLEMENTARY NOTES  Prepared by the Materials and Processes Laboratory, Engineering Directorate					
14. ABSTRACT  A stress corrosion evaluation was performed on a 0.05-in-thick sheet of Elgiloy alloy because this material was proposed as a spring material in the Universal Waste Management System. Bent-beam specimens survived a year-long exposure to concentrated alternate pretreat stabilizer, diluted pretreat stabilizer, and 3.5% sodium chloride alternate immersion at stresses of up to 90% yield strength. No reduction in tensile strength resulted from exposure and metallography showed no indications of stress corrosion. These results indicate that this material, at the strength level tested (215 ksi UTS) is resistant to stress corrosion cracking in the three environments in which it was tested.					
15. SUBJECT TERMS International Space Station, Environmental Control and Life Support System, Universal Waste Management System, stress corrosion cracking, metallic materials, alternate pretreat stabilizer, Elgiloy alloy, bent-beam assembly, double-beam specimen, constant deformation, deflection, constant load					
16. SECURITY CLASSIFICATION OF:			17. LIMITATION OF ABSTRACT	18. NUMBER OF PAGES	19a. NAME OF RESPONSIBLE PERSON
a. REPORT	b. ABSTRACT	c. THIS PAGE			STI Help Desk at email: help@sti.nasa.gov
U	U	U	UU	50	19b. TELEPHONE NUMBER (Include area code) STI Help Desk at: 757-864-9658



National Aeronautics and  
Space Administration  
IS02  
**George C. Marshall Space Flight Center**  
Huntsville, Alabama 35812