

3-Stage ADR for the X-Ray Imaging and Spectrometer Mission (XRISM)

Peter Shirron, Mark Kimball and the rest of the ADR team

Cryogenics and Fluids Group

NASA/Goddard Space Flight Center

Greenbelt, MD 20771 USA



Hitomi (formerly Astro-H)

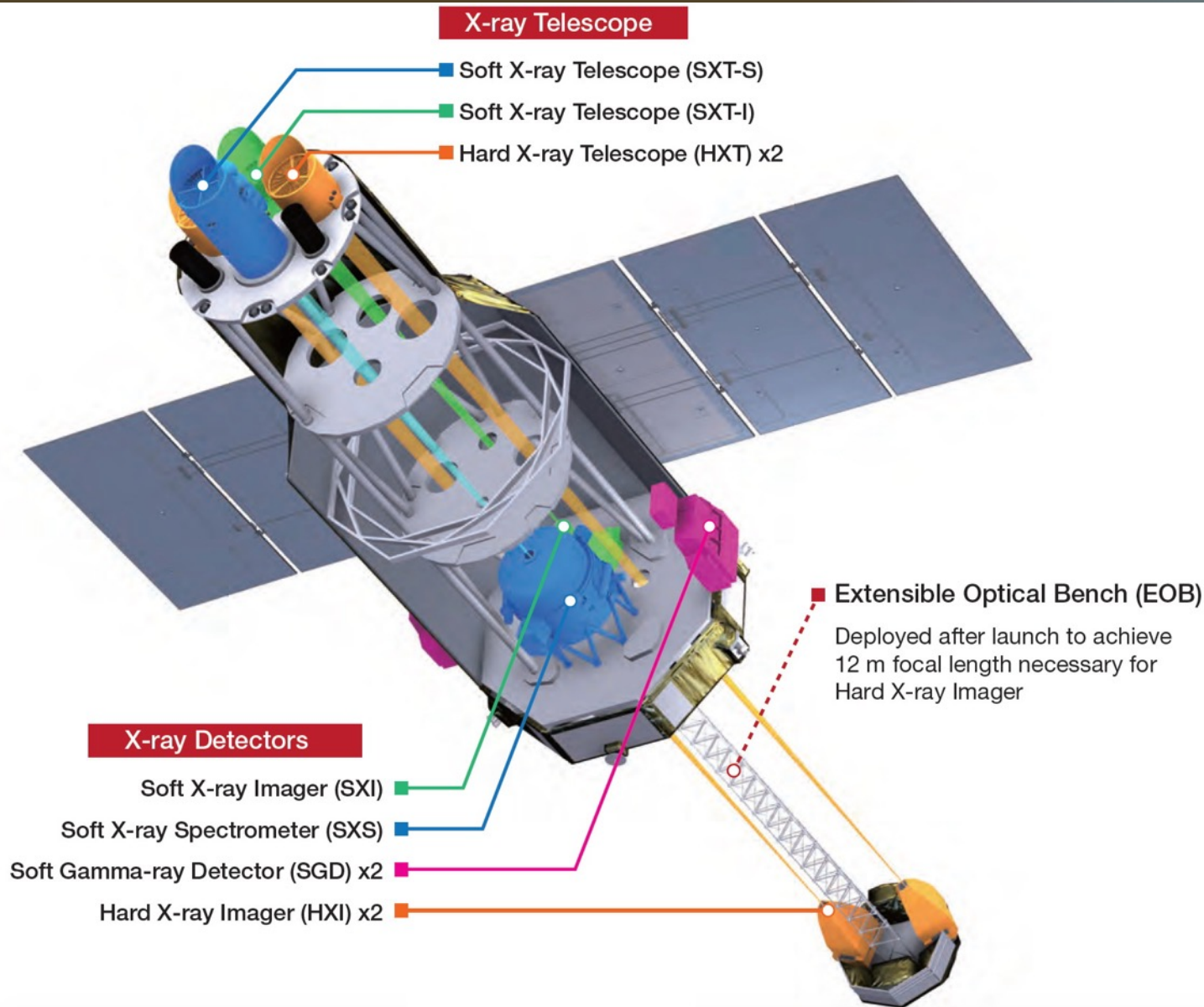

Study structure and evolution of the Universe

Study matter in extreme environments

- Black holes
- Galaxies
- Heavy elements
- Cosmic rays

The Resolve X-ray Spectrometer

- 6x6 array of silicon microcalorimeters
 - High resolution imaging and spectroscopy of x-rays in the 0.2-13 keV band
- ADR for detector cooling
 - 50 mK operation

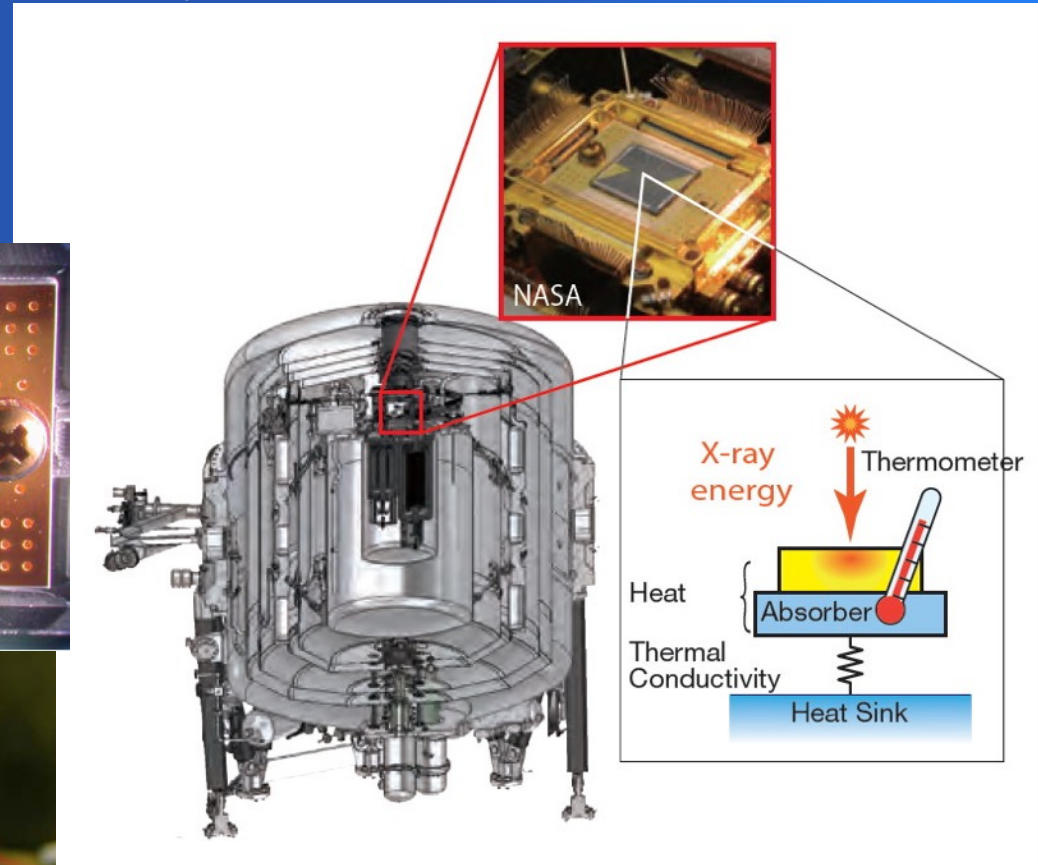
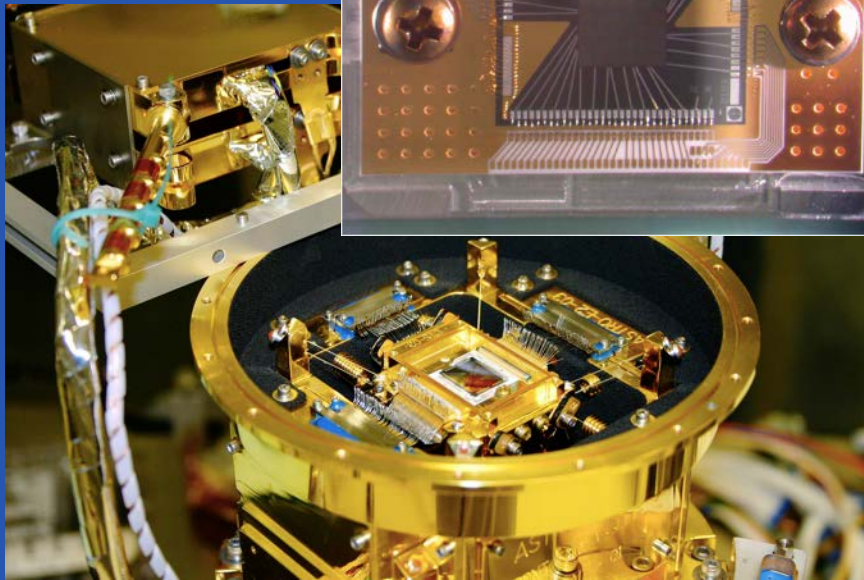
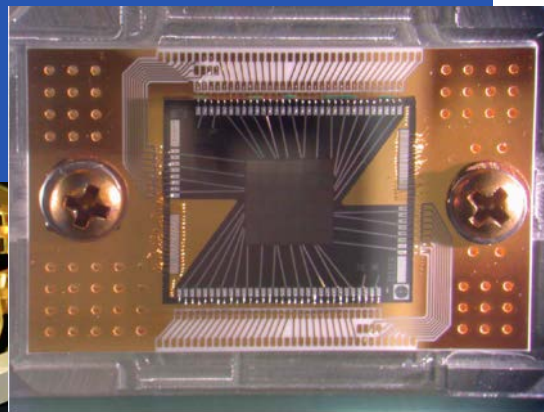

Low temperature \Leftrightarrow low heat capacity
 $\Delta E \sim 4\text{-}5 \text{ eV}$ for 0.2-13 keV x-rays

ADR Operation with Liquid Helium

2-stage ADR uses liquid helium as a heat sink

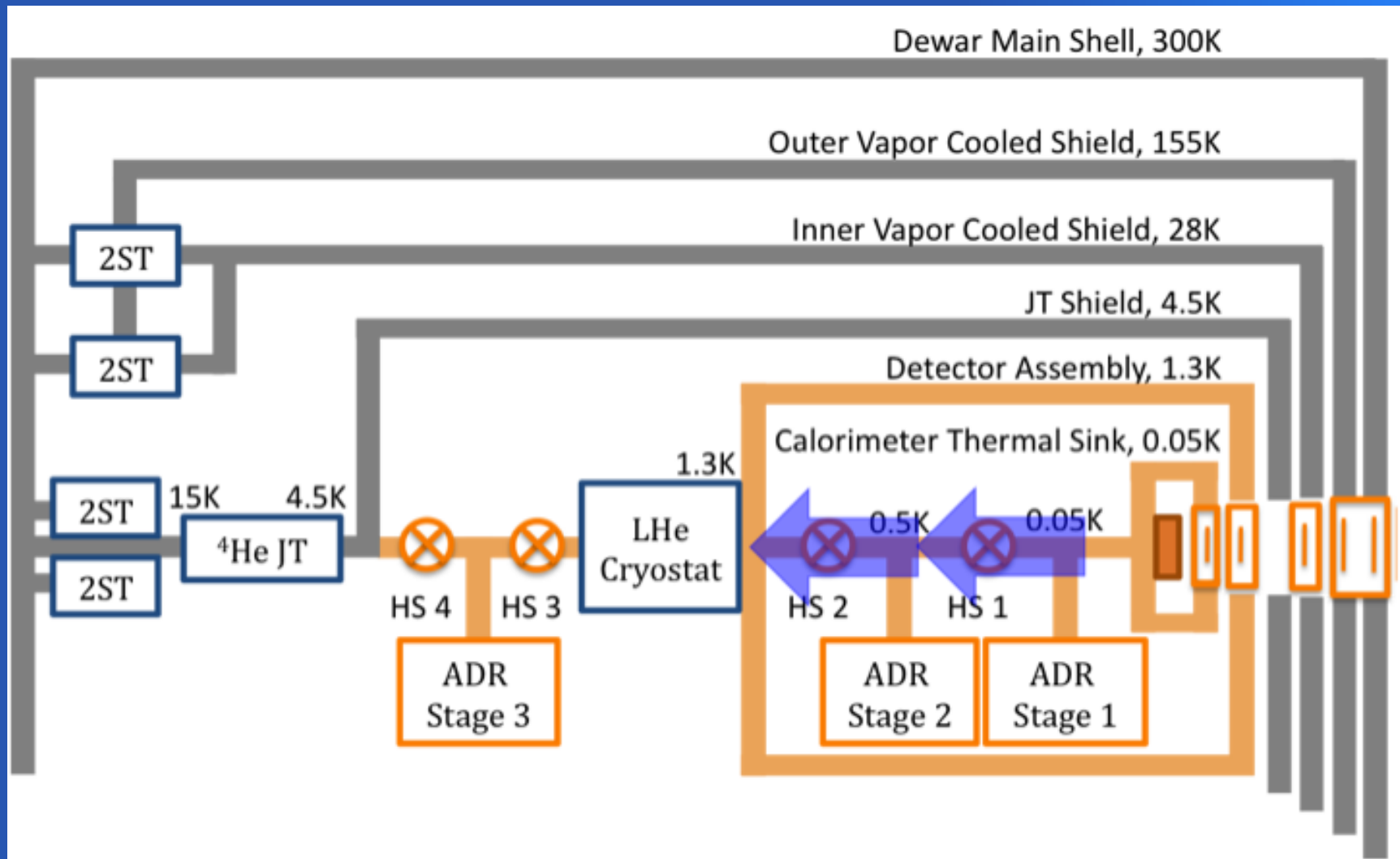

ADR Operation in Cryogen-Free Mode

- 3rd stage transfers heat from tank to JT cooler
- 2nd stage stabilizes helium tank at ~ 1.5 K
 - 2nd stage decouples from tank to precool 1st stage to 0.8 K
- 1st stage cools detectors from 1.3 K
 - 2nd stage decouples from tank to precool 1st stage to 0.8 K

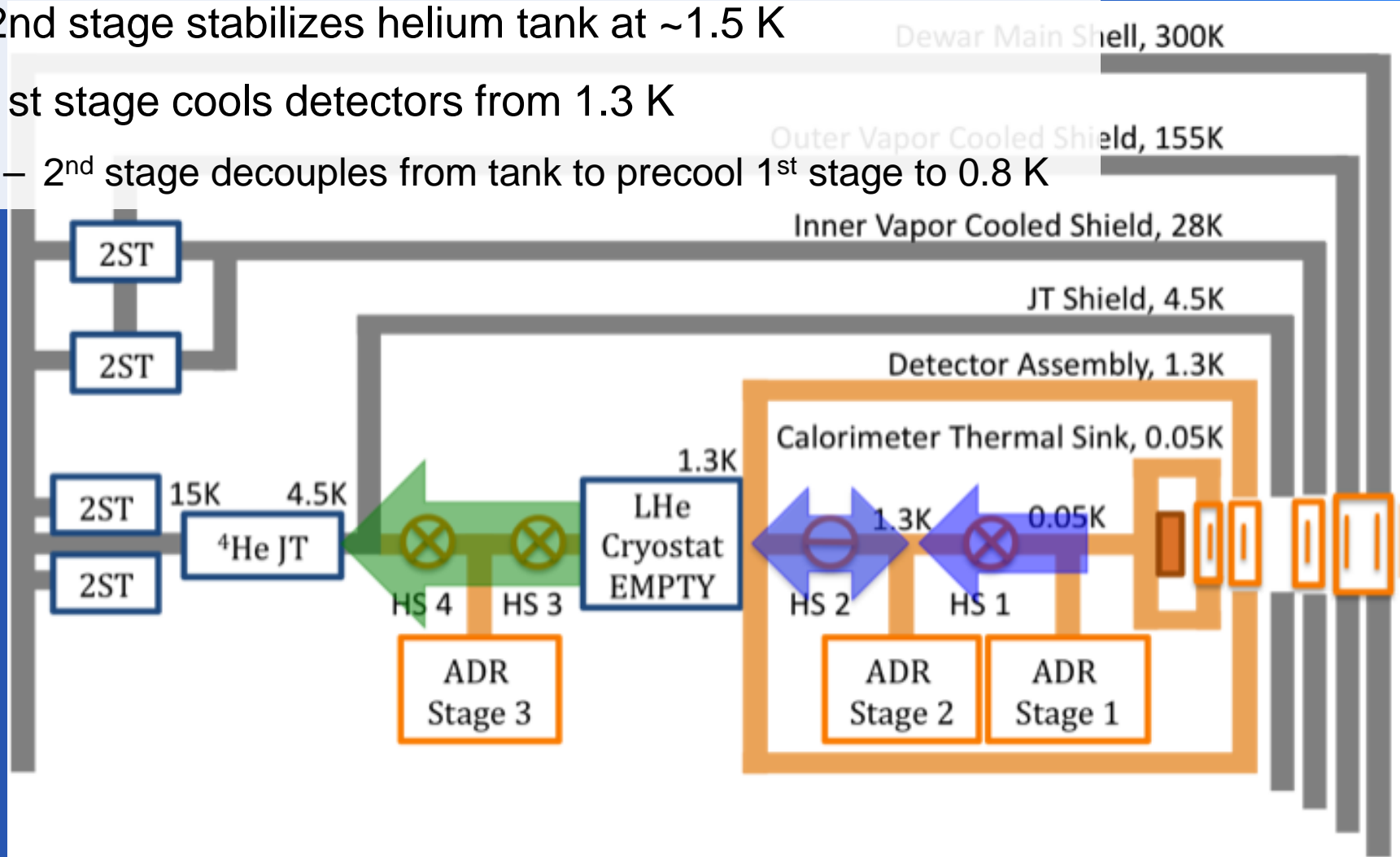

SXS ADR Layout

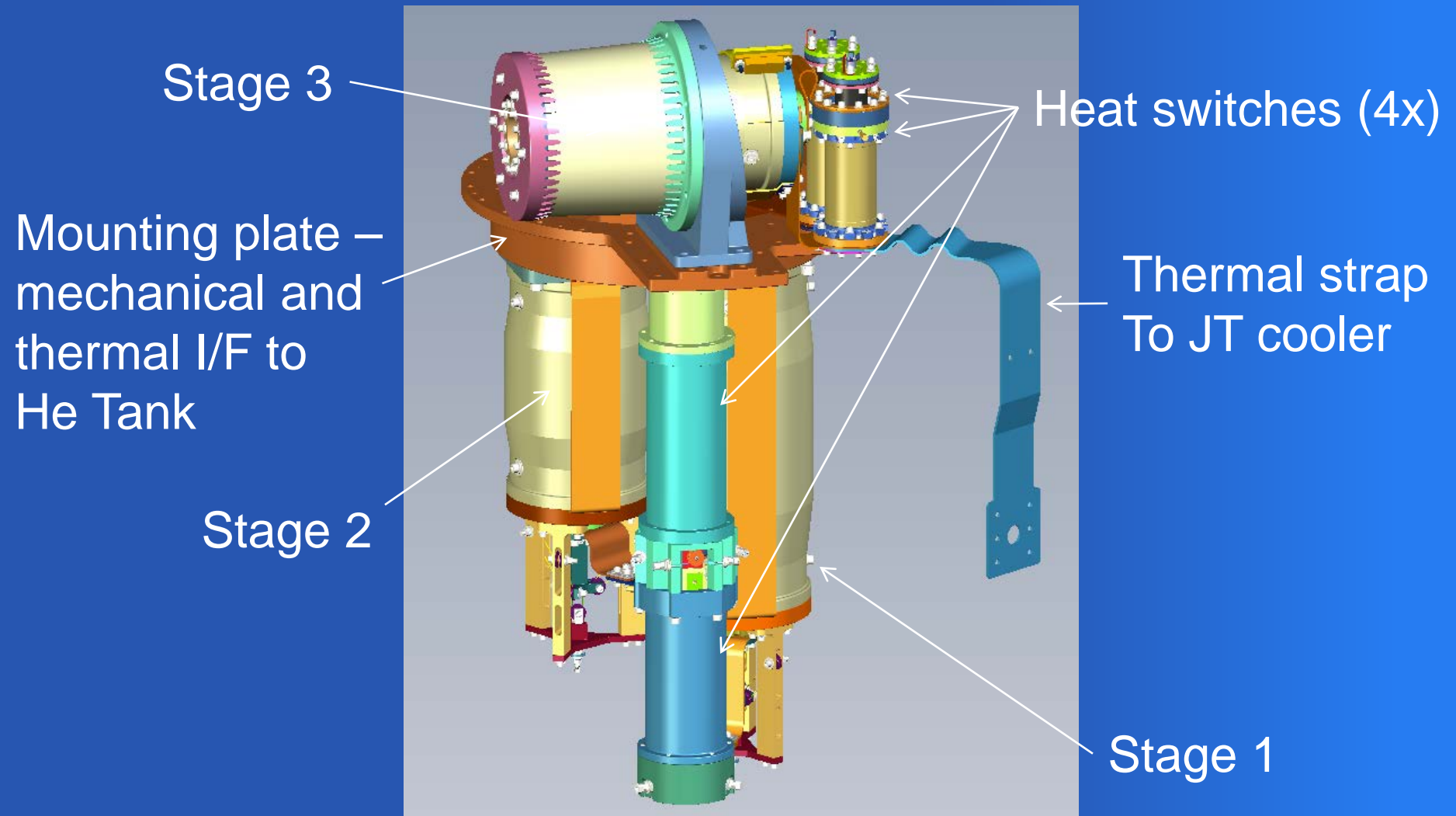

ADR Assemblies

Stage 1:

- 270 g CPA
- 2 T, 2 amp magnet

Stage 2:

- 150 g GLF
- 3 T, 2 amp magnet

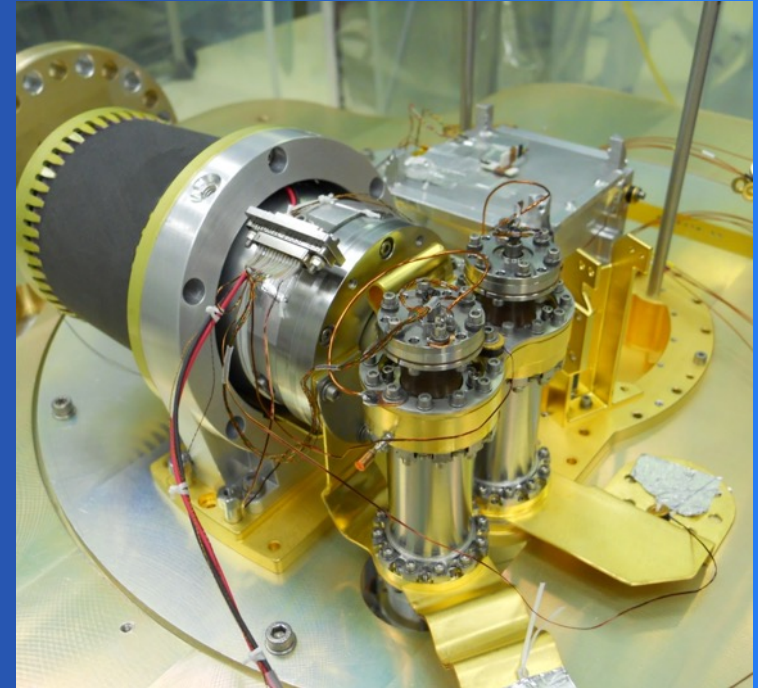
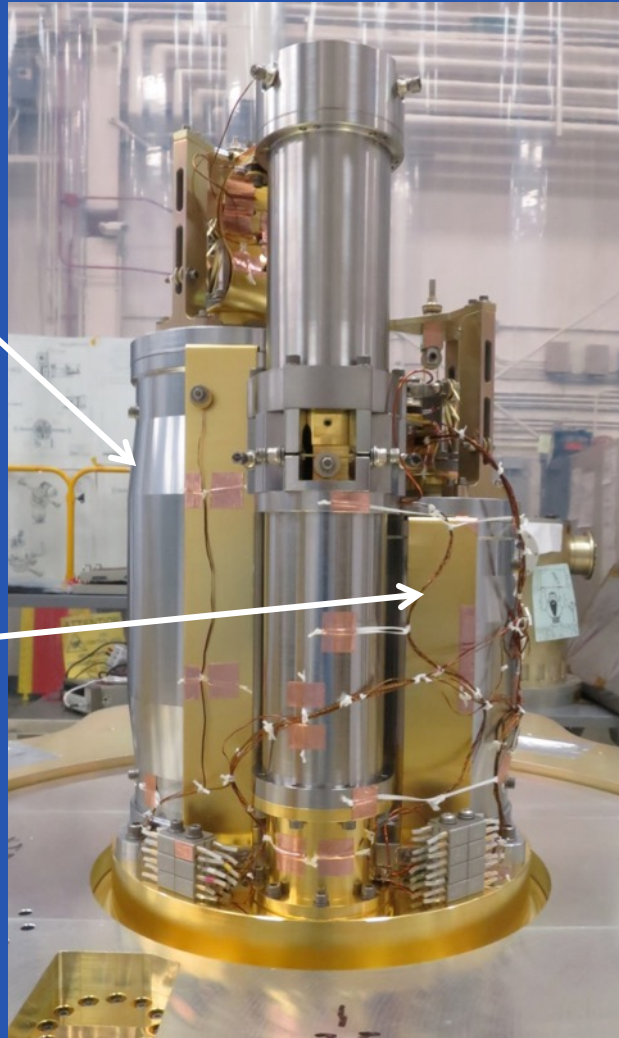

Stage 3:

- 150 g GLF
- 3 T, 2 amp magnet

Heat switches are all active gas-gap

Changes for XRISM

- Some changes based on observed performance of Hitomi
 - High energy particle hits to temperature sensors
- Others based on performance limitations observed during ground testing
 - Interactions between stage 3 magnetic field and detectors
 - Excessive noise observed when magnet current was above 1.75 A (nom 2 A max)
 - Reduced cooling power in cryogen-free mode

Effect of High Energy Particles

- Response appears to be primarily within thermometers
- Concentrated in SAA
 - Too intense to produce useful science data

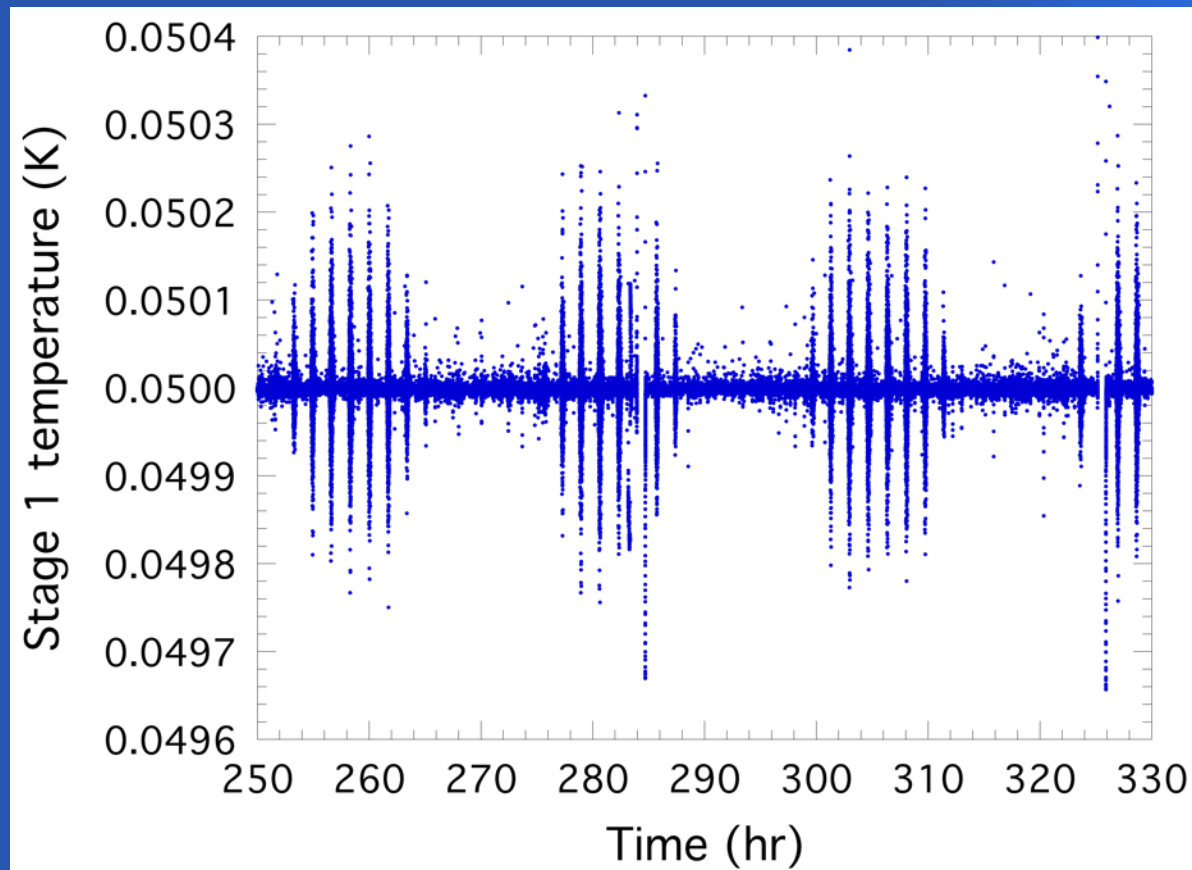

Temperature Stability

- Negative pulses are the ADRC reaction to hits on control thermometer
- Implementing a control veto on readings significantly above noise

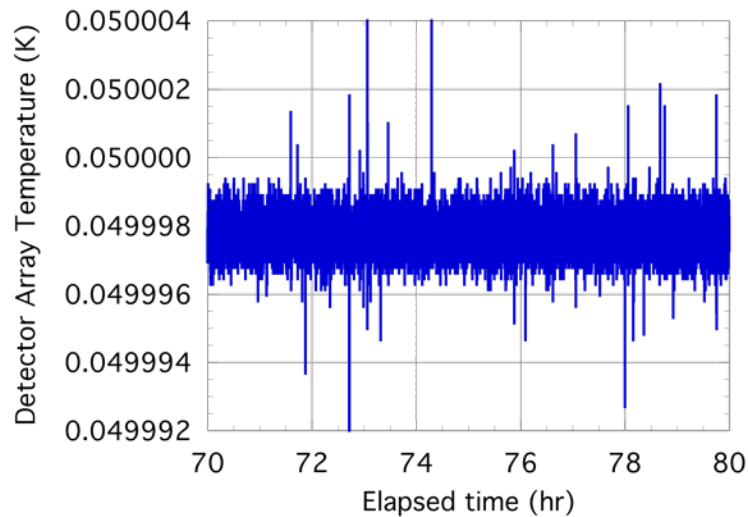

Ground tests: $\sim 0.4 \mu\text{K rms}$

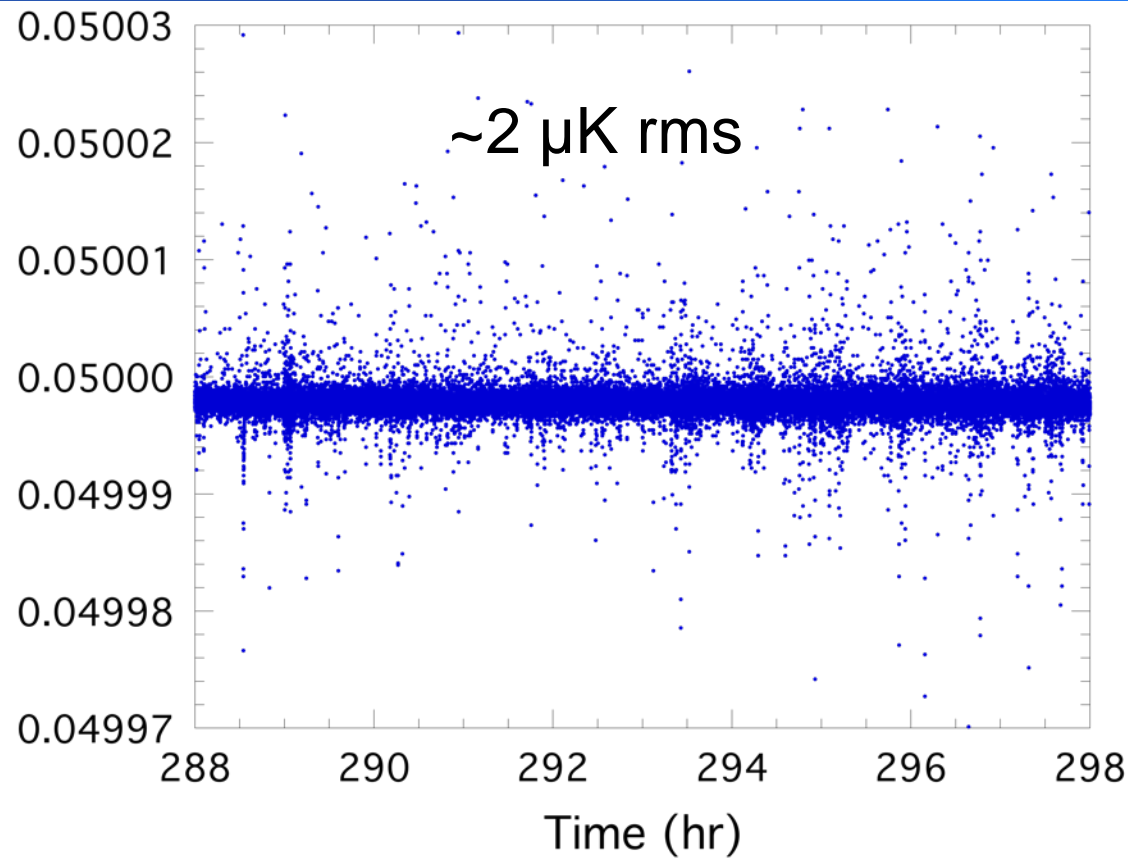

On orbit: $\sim 2 \mu\text{K rms}$

Changes for Resolve

- Reduce ADR controller response to cosmic ray events
 - Suppress response to a reading outside a narrow band at 50 mK

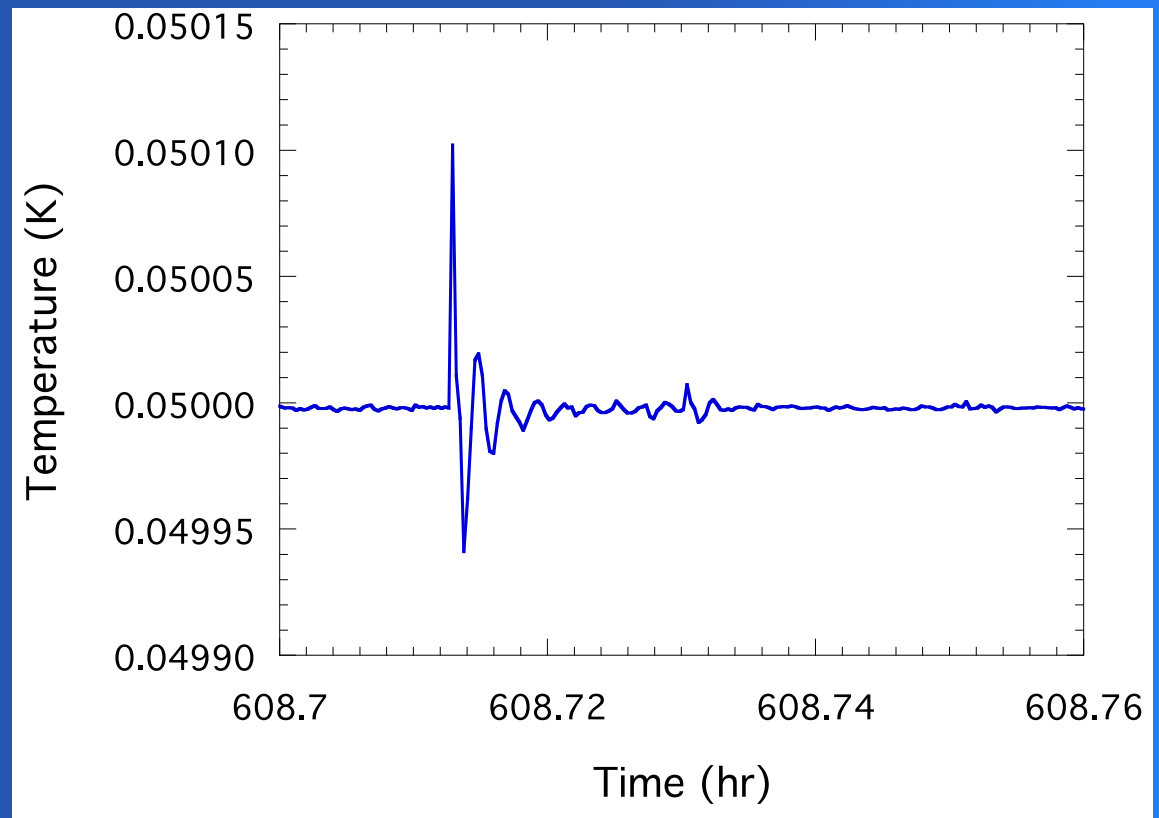

ADR Operation in Cryogen-Free Mode

- 3rd stage transfers heat from tank to JT cooler
- 2nd stage stabilizes helium tank at ~ 1.5 K
 - 2nd stage decouples from tank to precool 1st stage to 0.8 K
- 1st stage cools detectors from 1.3 K
 - 2nd stage decouples from tank to precool 1st stage to 0.8 K

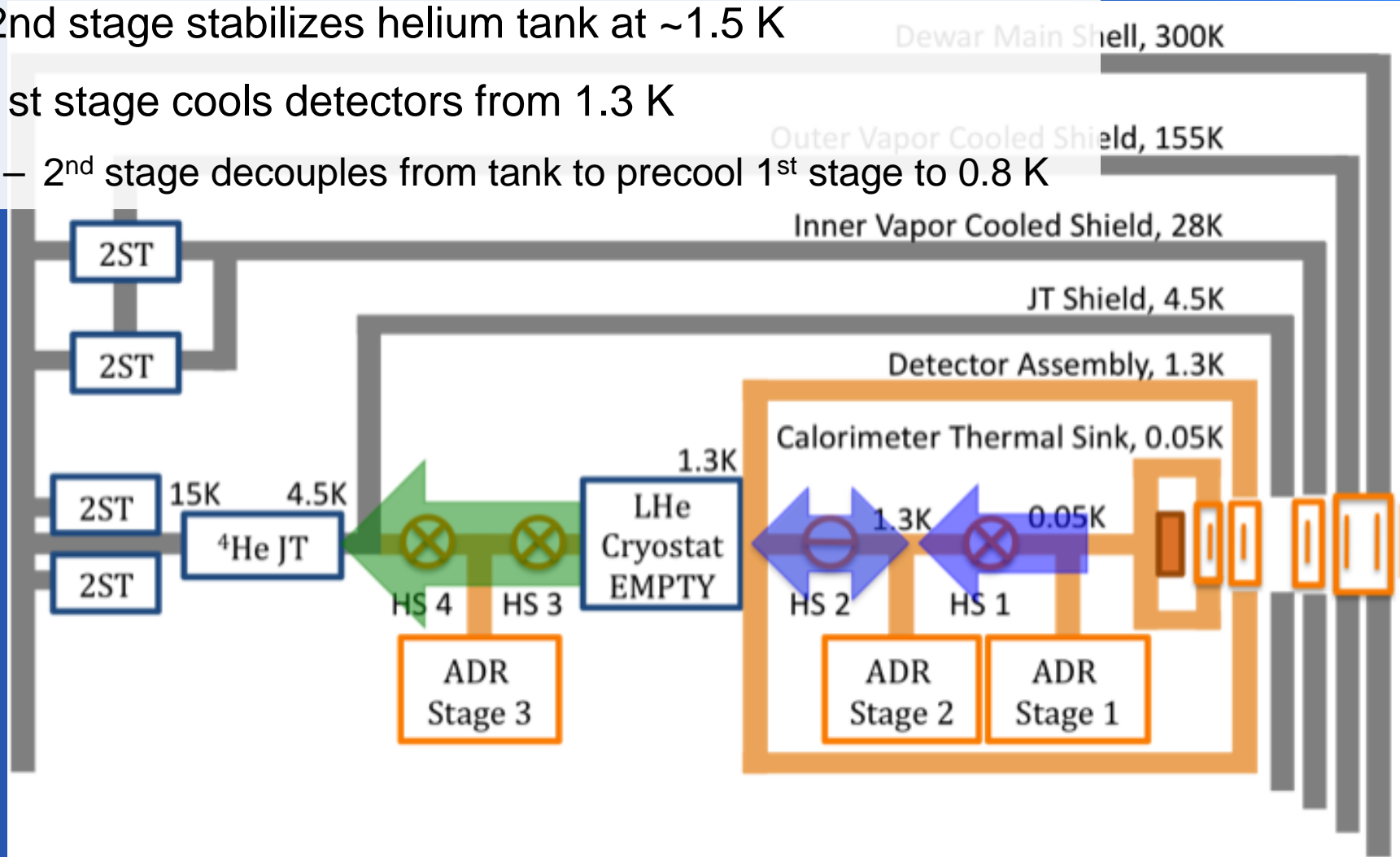

Continuous ADR Cooling

- Stages 2 and 3 operate together as a continuous ADR to cool the helium tank

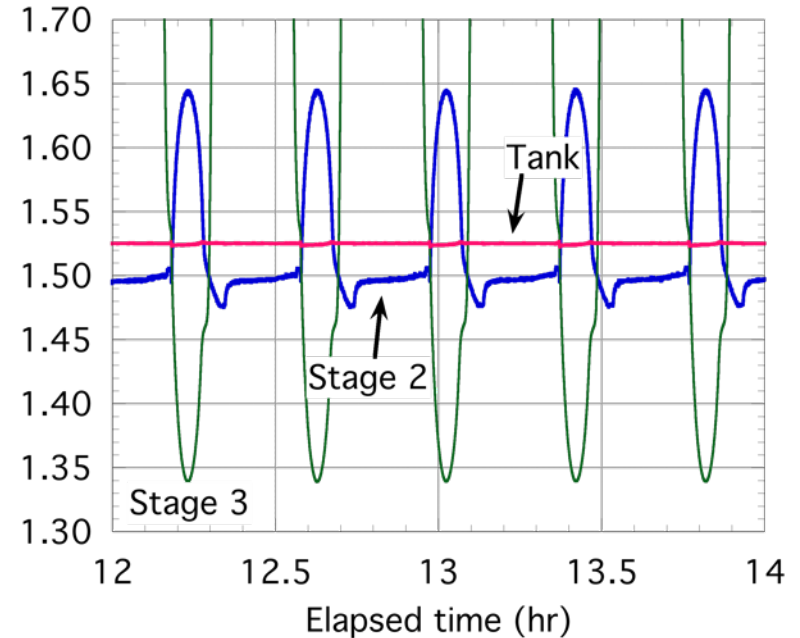
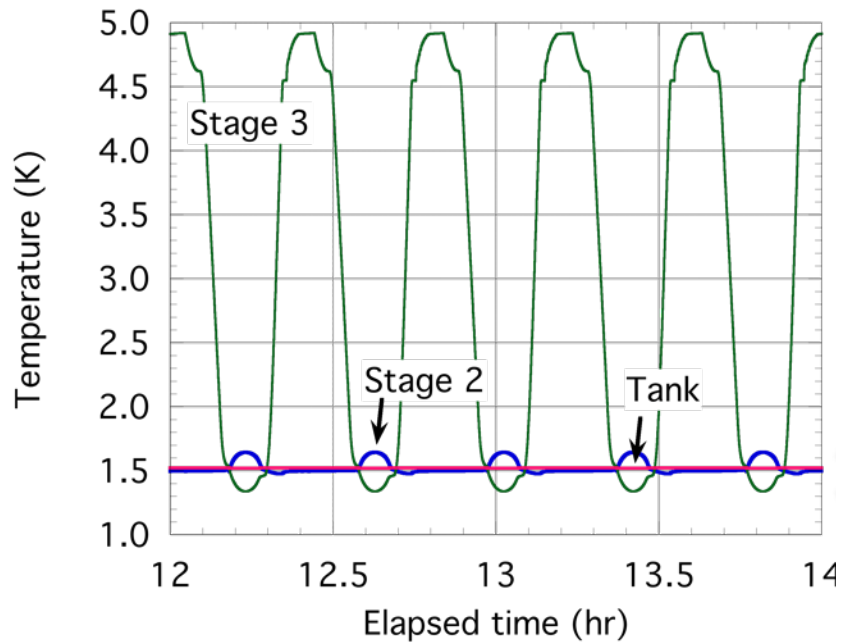

Full Cycle with He tank at 1.525 K

- Limitation on Stage 3 current reduced cooling power, requiring operation at higher temperature (1.525 K)
 - Shorter hold time
 - Longer recycle time
 - Lower duty cycle, ~80%

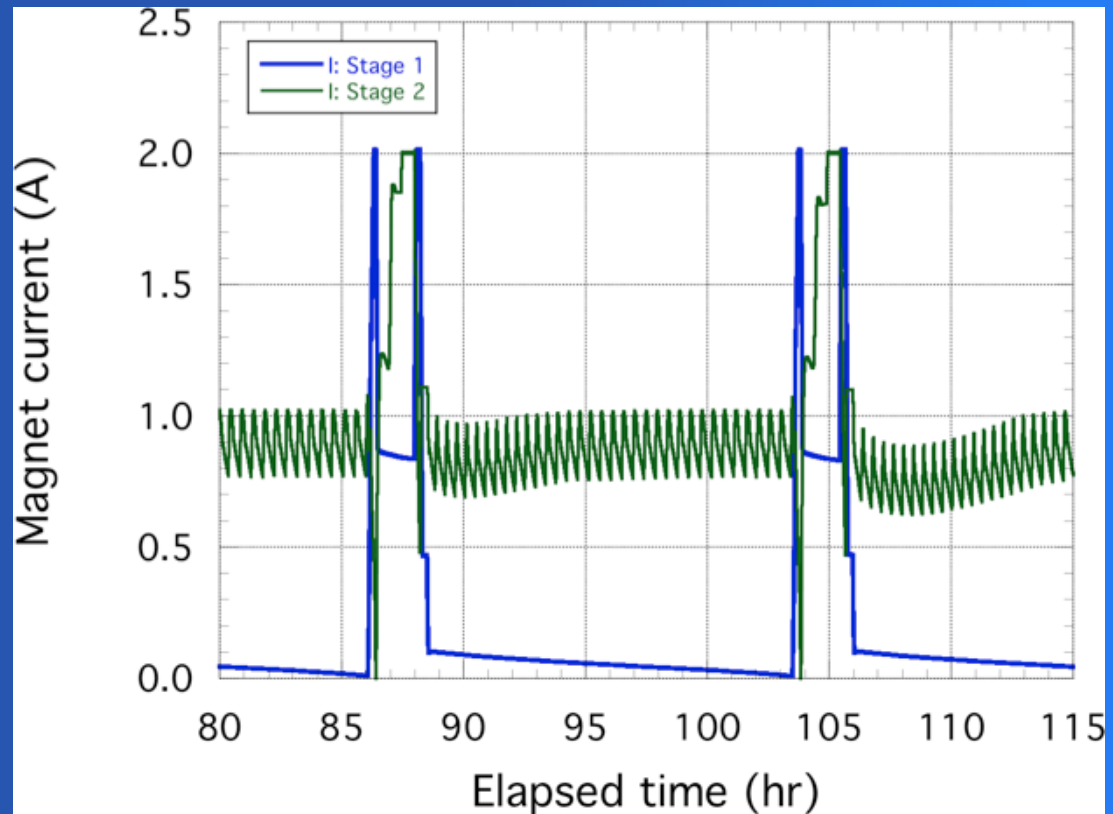

Changes for Resolve

- Increase magnetic shielding of ADR Stage 3
 - 1.5 mm increase in magnetic shield thickness (~200 grams) reduced fringing fields by an order of magnitude
 - Change has been directly verified (1.5 Gauss at detector location)

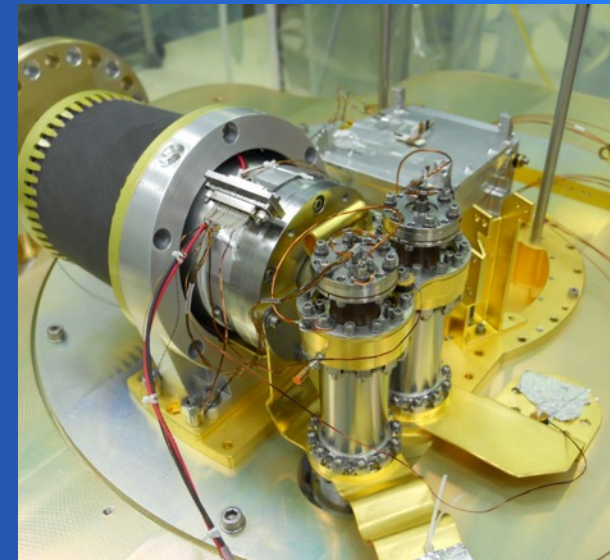
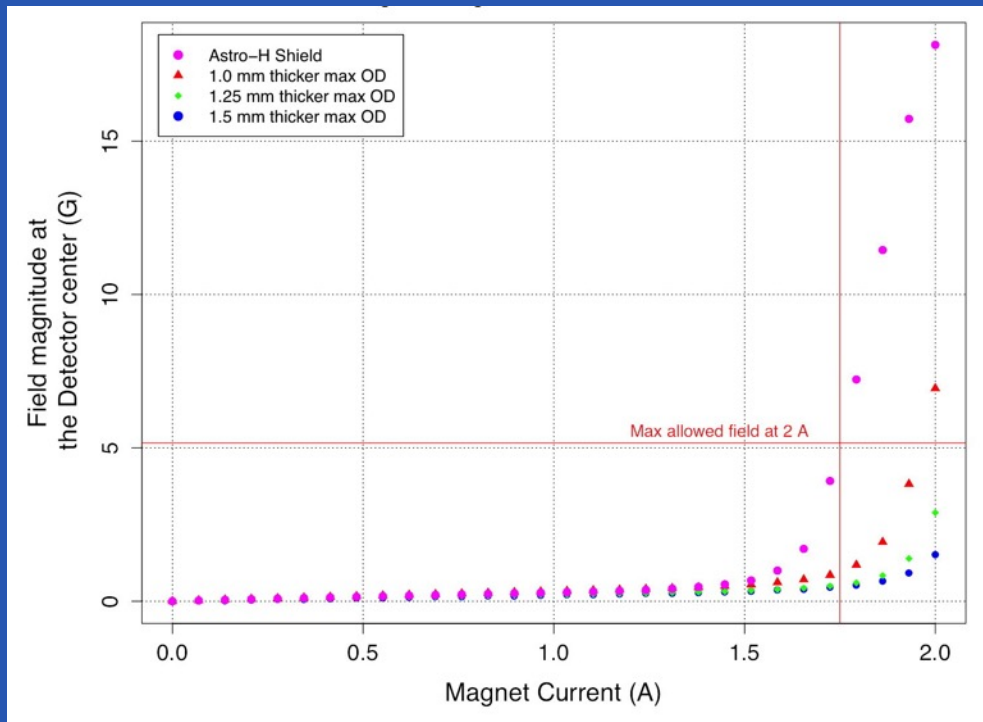

Modeled performance

XRISM FM ADR Performance

- Stable operation obtained at 1.4 K
 - Warm start from 4.5 K in ~4 hours
 - 21 hour hold at 1.4 K
 - 45 minute recycle
 - 96% duty cycle

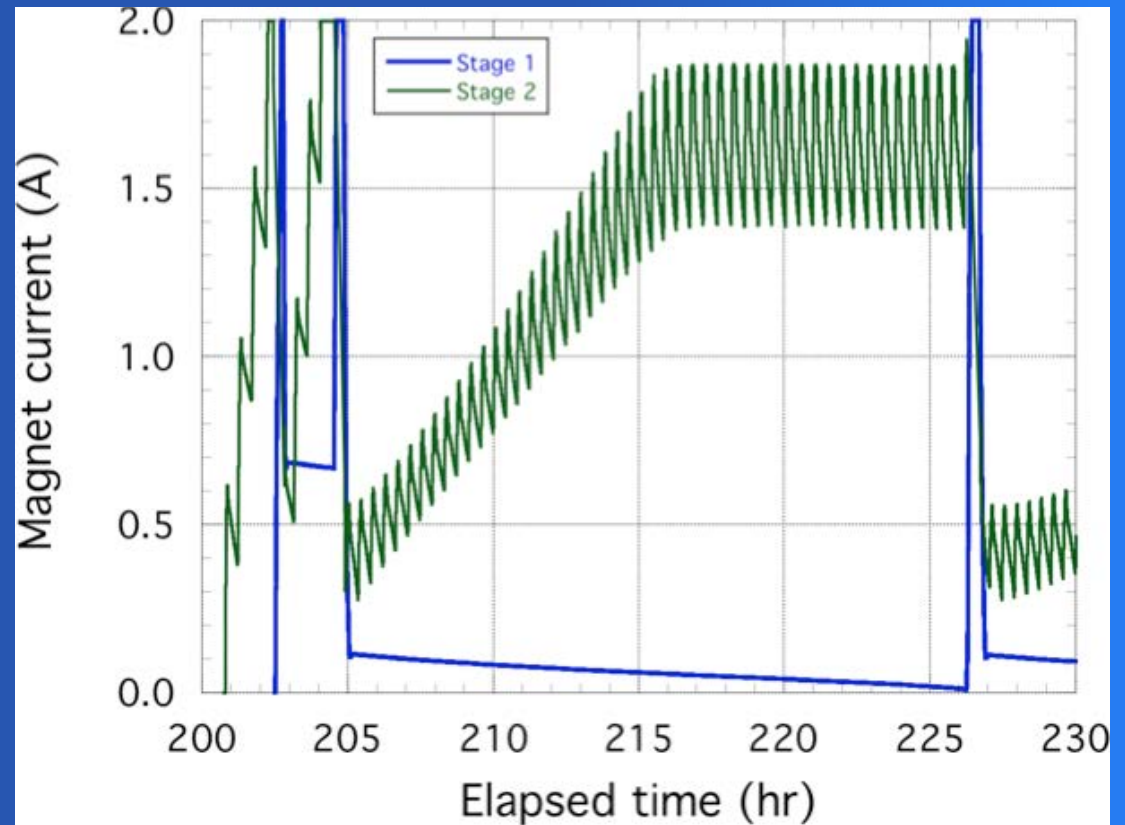

Summary

- XRISM received final approval for funding by JAXA in mid-2018
 - Launch is currently scheduled for early 2022
- The Resolve instrument is essentially a built-to-print copy of SXS
 - Limited number of changes based on experience with ground and on-orbit performance
- CAUTION: SXS was not fully demonstrated on orbit
 - Gate valve was not opened to expose the detectors to full energy range of x-rays
 - Long-term performance (cryocoolers, progressively smaller LHe volume)
 - Environmental effects: micrometeoroid damage, residual helium