



Progress Towards Modeling The Mars Science Laboratory PICA-NuSil Heatshield

PICA-N Response Model Development / The Problem



- **Surface temperature discontinuity during ARC Jet testing as measured by pyrometer.**

- **State of the art material response models do not account for the observed surface temperature discontinuity.**

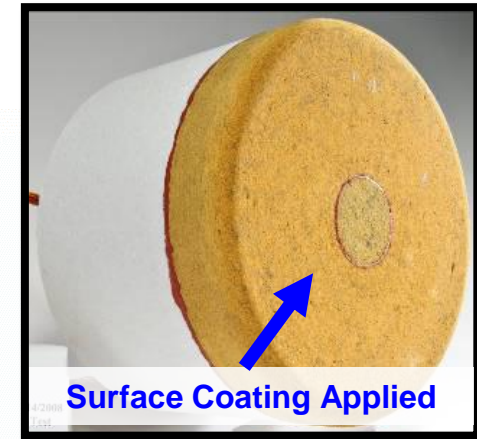
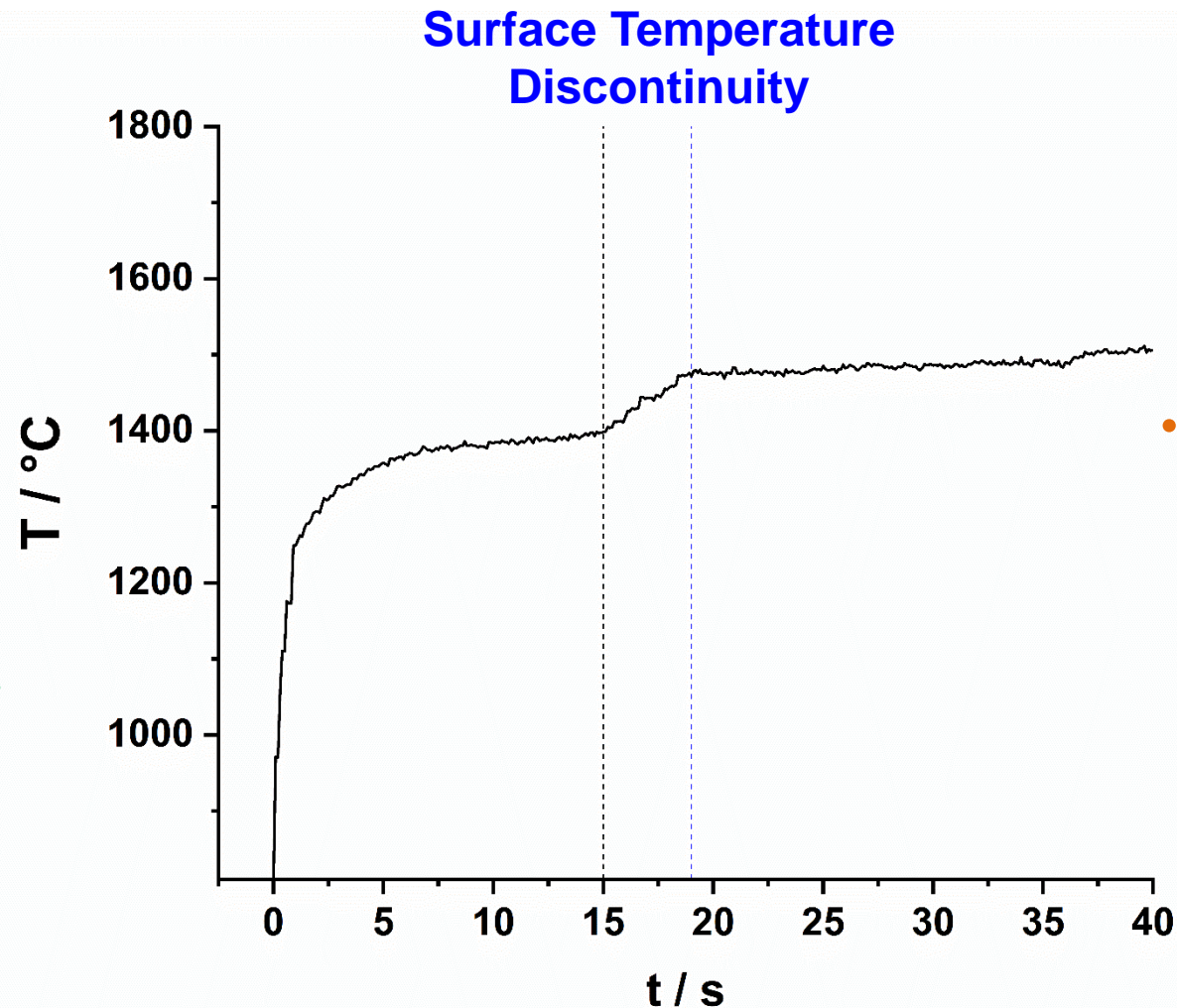

- **MEDLI Integrated Sensor Plug (MISP) Qualification During Arc-Jet Test Campaign.**

MISP Qualification Run 1 Surface Temperature with NuSil Coating: 85 W/cm²

NuSil Coating Process Development



Application of NuSil to PICA Mini-Sprite

Virgin PICA

3 Box Coats

8 Box Coats



Mini-Sprite O.D. ~ 1.83"

Reported NuSil coating on Lockheed Martin coated 3" x 3" coupons: < 3 Box Coats

NuSil diluted with VM&P Naphtha until a viscosity of 18 seconds is achieved as measured with a #2 Zahn cup.



Diluted NuSil solution applied with a Paasche air brush.



General Application Process

.3" spray spot size
.05" halo

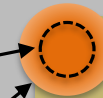

Double pass
= 1 Box Coat

PICA Sample

NuSil Coating Thickness



Penetration Depth of NuSil Coating.

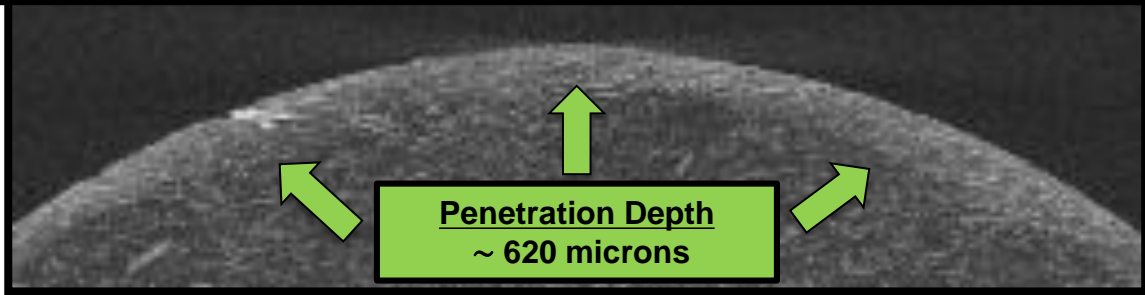

Coating Thickness of MSL-era PTF Panel.

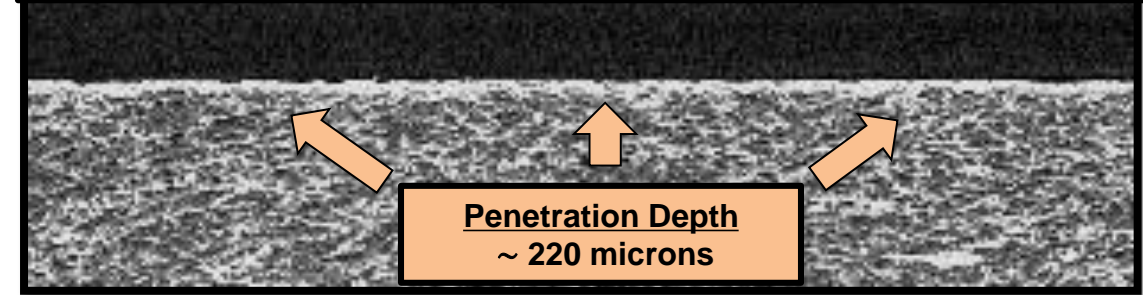

PICA-N Mini-Sprite Model

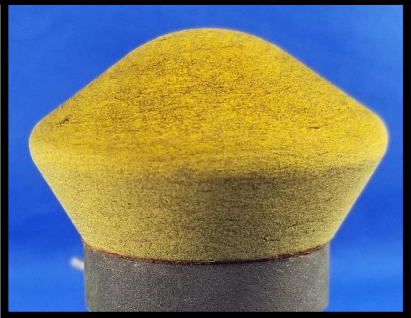

- Mini-Sprite models coated applied at AMES.
- 3 box coats.
- Penetration depth ~ 620 microns.
- Nonhomogeneous in-depth distribution of coating.

Panel Section



- Panel coated by LMA.
- Number of box coats unknown.
- Penetration depth ~ 220 microns.
- Nonhomogeneous in-depth distribution of coating.

Mini-Sprite O.D. ~ 1.83 in.

Panel Section = 1.00 in²

HyMETS PICA-N Mini-Sprite Campaign



**HyMETS Test Campaign
March 2019.**

Mini-Sprite O.D. ~ 1.83"

HyMETS Test Geometry

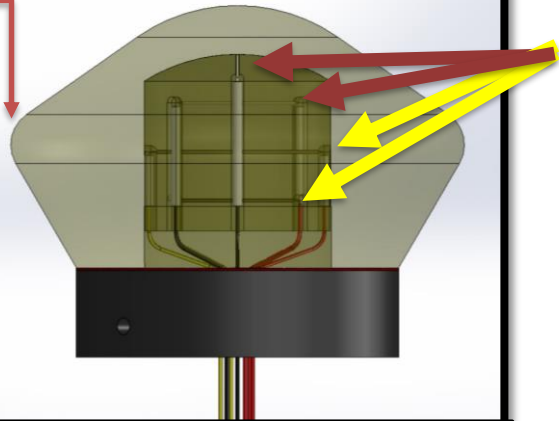

Mini-Sprite Model

Mini-Sprite architecture chosen to study viscous flow in shear environment.

- PICA and FiberForm models (22 Models in Total) with various numbers of box coats (e.g., 0, 3, 8).
- Data collected in 3 atmospheric environments (e.g. Air, N₂, CO₂).
- Each model instrumented with thermocouples to measure in-depth temperature and a pyrometer to measure surface temperature.
- Two R-type thermocouples and two K-type thermocouples spaced ~ 5mm apart.
- Suite of spectrometers used to analyze species in the post-shock region.

High Speed Cameras

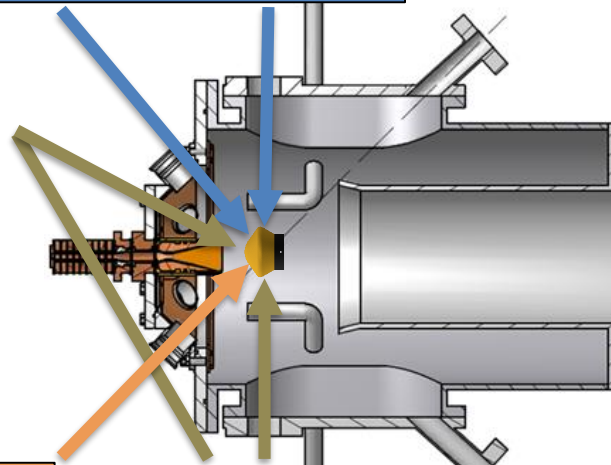

Pyrometer (s)

Spectrometers

PICA-N HyMETS Test Conditions

Material	Model Number	Simulated Atmosphere	Heat Flux (W/cm ²)	Stagnation Pressure (kPa)	Duration (s)
PICA-N	1	Earth	140	5.6	28
PICA-N	2	Earth	140	5.6	30
PICA-N	3	Earth	140	5.6	30
PICA-N	4	Earth	60	4.1	67
PICA-N	5	Earth	224	6.6	29
PICA-N	6	N ₂	131	5.3	29
PICA-N	7	Mars	127	5.2	33
PICA-N	8	Earth	60	3.9	30
PICA	9	Earth	140	5.6	30
PICA	10	N ₂	130	5.3	30
PICA	11	Earth	223	6.6	21
PICA	12	Mars	126	5.3	31

FiberForm-N HyMETS Test Conditions

Material	Model Number	Simulated Atmosphere	Heat Flux (W/cm ²)	Stagnation Pressure (kPa)	Duration (s)
FF-N	1	Earth	128	5.3	11
FF-N	2	Earth	141	5.6	9
FF-N	3	Earth	126	5.3	6
FF-N	4	Earth	59	4.1	32
FF-N	5	N ₂	132	5.3	30
FF-N	6	Mars	127	5.1	7
FF-N	7	Earth	141	5.6	30
FF	8	Earth	141	5.6	7
FF	9	N ₂	134	5.3	30
FF	10	Mars	128	5.2	25

HyMETS Campaign High-Speed Video (45°)

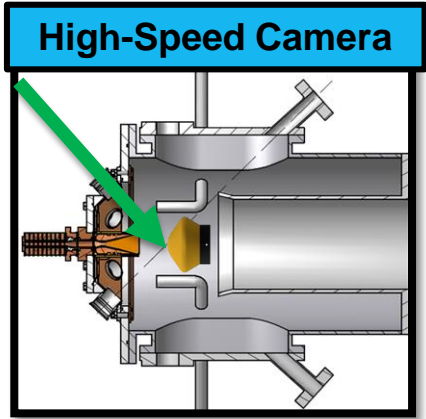

8 Box Coats

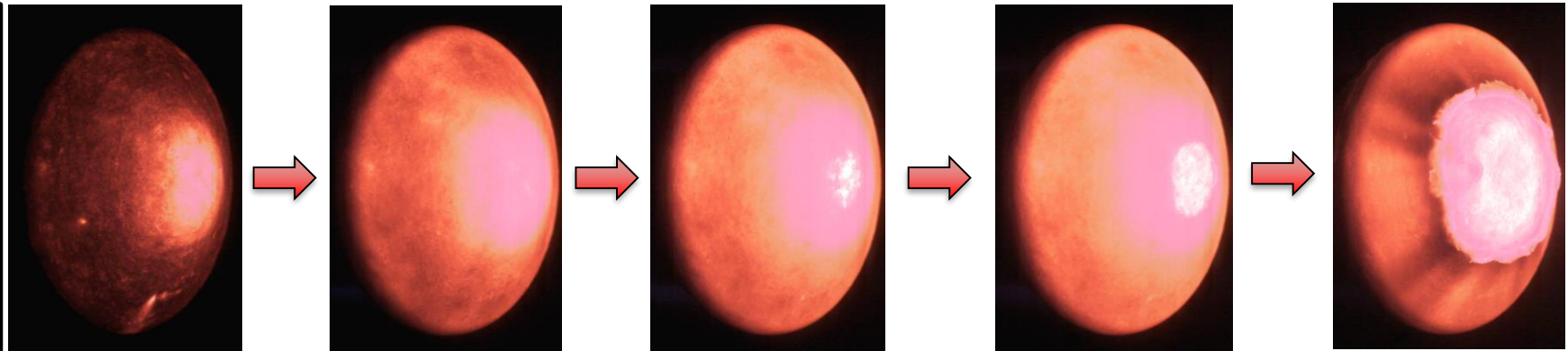

3 Box Coats

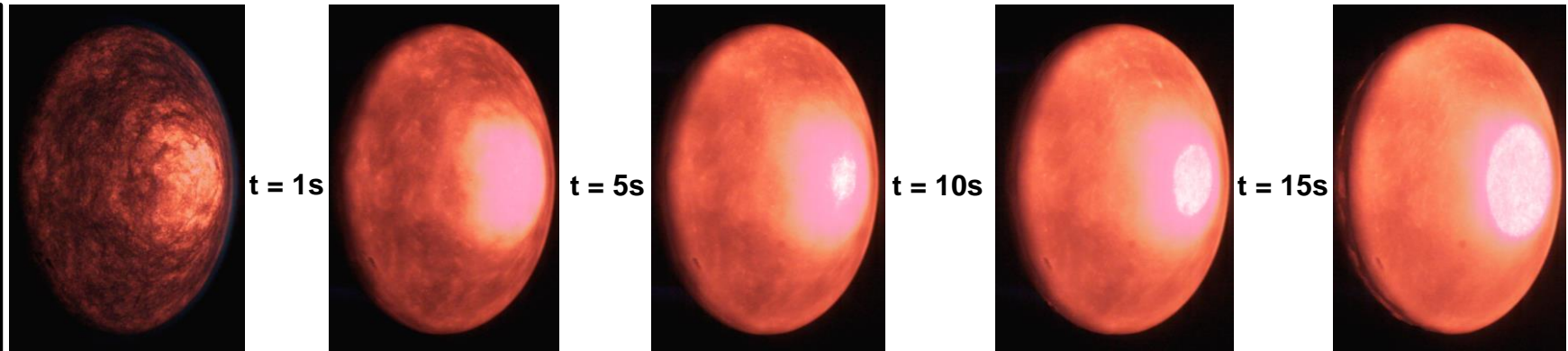

Test Conditions

Atmosphere: **Air**

Heat Flux: $\sim 140 \text{ W/cm}^2$

Test Length: 30 Seconds

0 Box Coats

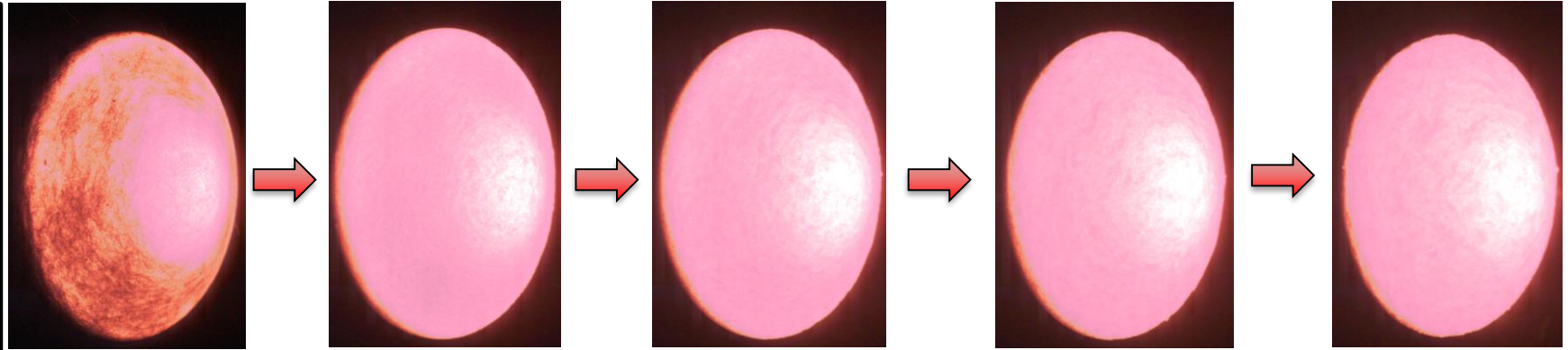

Development of the Model

PICA-NuSil Surface Response / Air

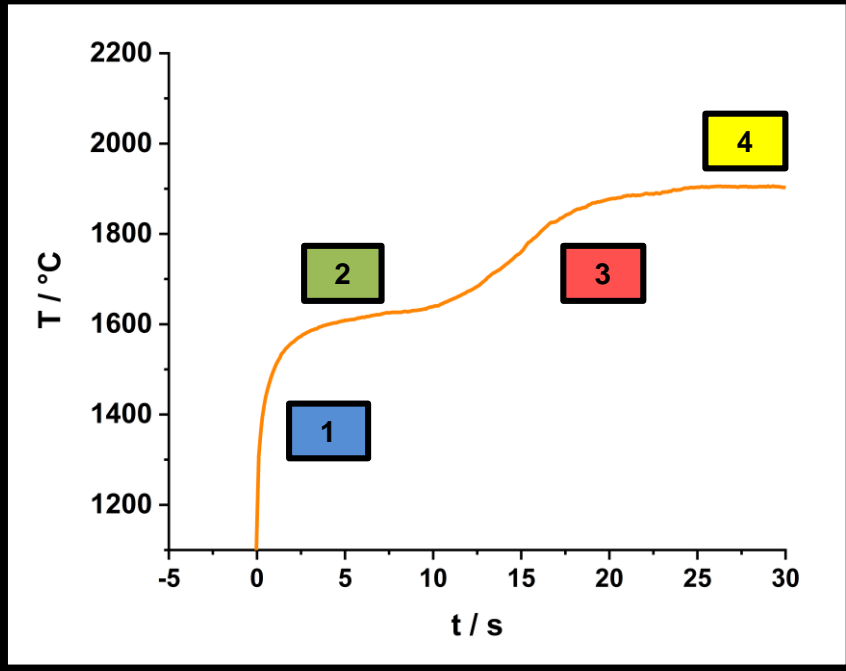

Top View of Surface Chemistry

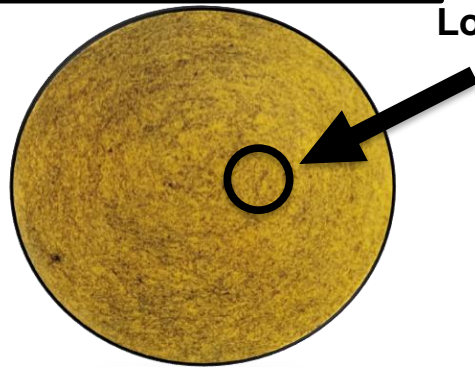

Location of Pyrometer Measurement

Stage 1 – Pyrolysis of NuSil Silicone Polymer

Time = 0 - 1s
Temp. = R.T. - 1500 °C

- Fast pyrolysis of silicone polymer.
- Major pyrolysis products include:

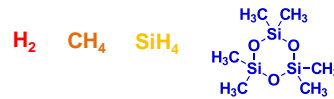

- Oxidation of thin amorphous $Si_xO_yC_z$ layer.

Stage 2 – Oxidation and In-Depth Phase Separation

Time = 1 - 10s
Temp. = 1500 - 1650 °C

- Persistent oxidation of $Si_xO_yC_z$ layer to form SiO_2 layer at the surface concomitant with in-depth phase separation of $Si_xO_yC_z$ to form SiO_2 , small domains SiC , and domains of graphitic carbon.



- Formation of SiO_2 melt layer.

Stage 3 – Carbothermic Reduction and Differential Recession

Time = 10 - 17s
Temp. = 1650 - 1900 °C

- Thin layers of SiO_2 , SiC , and carbon react to form SiO and CO (Carbothermic Reduction).



- Carbothermic reduction initiates the breakdown of a stable surface coating which exposes the underlying char layer.

- Char layer recedes at a higher rate than the $Si_xO_yC_z$ surface leading to differential recession.

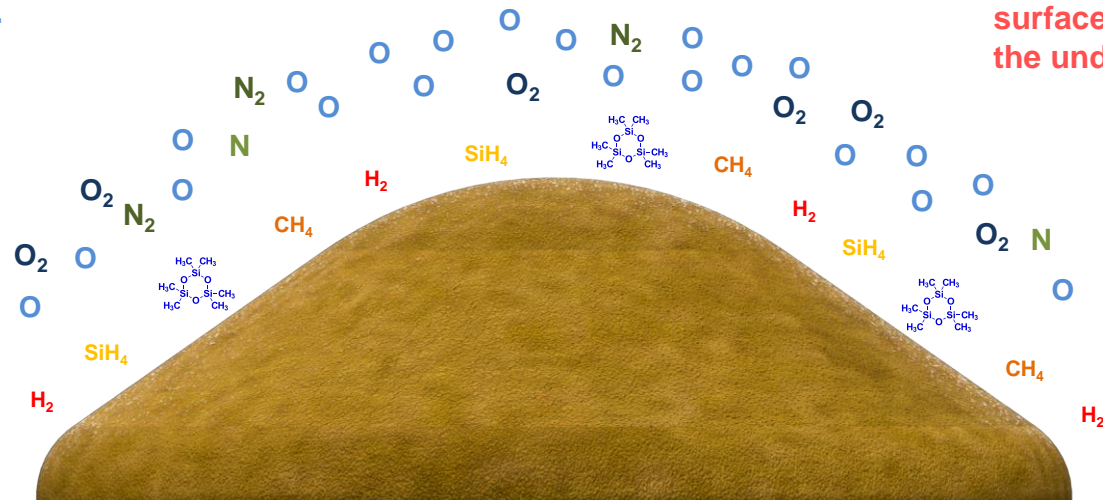

HyMETS Campaign High-Speed Video (45°)

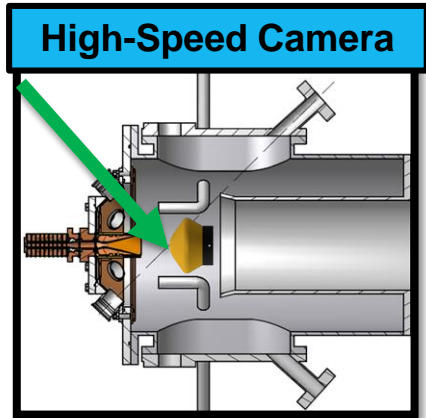

3 Box Coats
~ 224 W/cm²

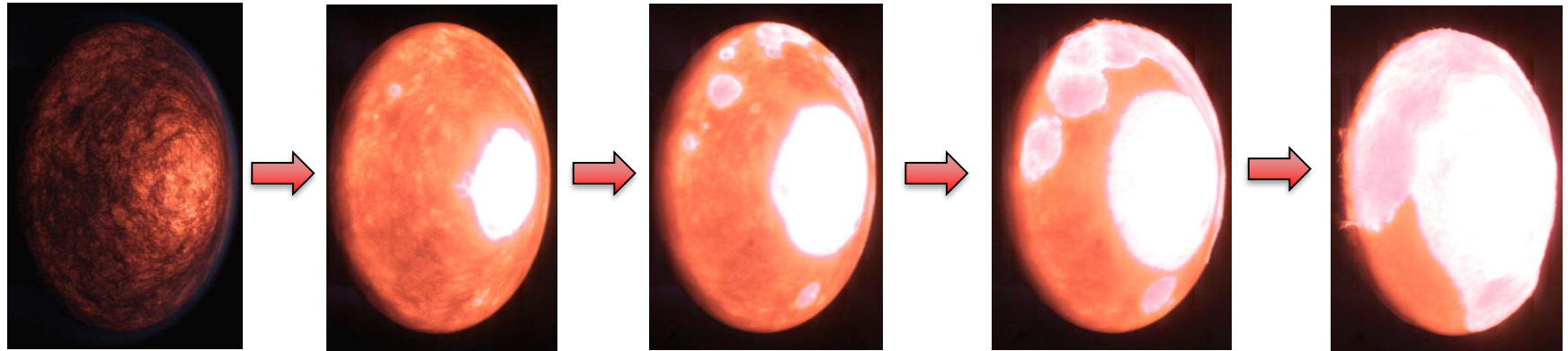

Test Conditions

Atmosphere: **Air**

Heat Flux: **Variable**

Test Length: **30 Seconds**

3 Box Coats
~ 140 W/cm²

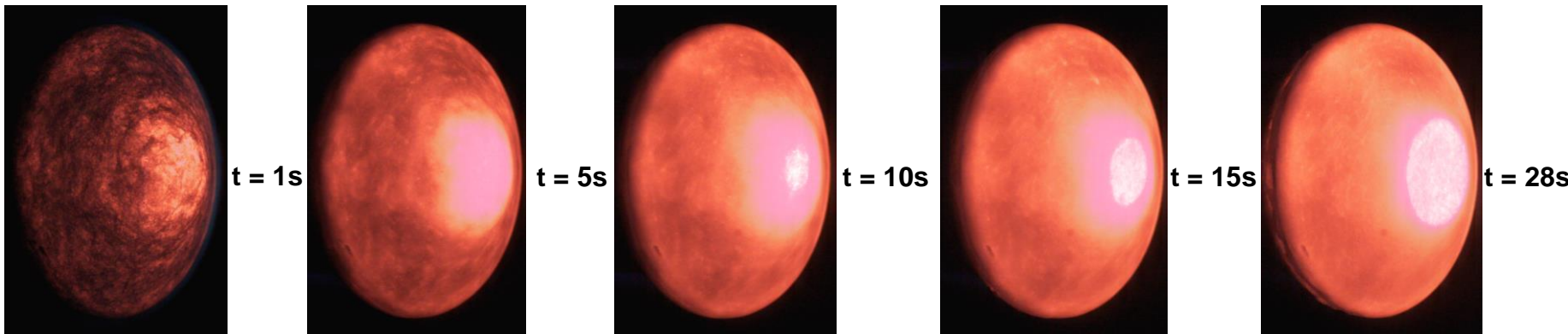

Differential Surface Recession

Post-Test PICA With NuSil Coating



Formation of SiO₂ rim.

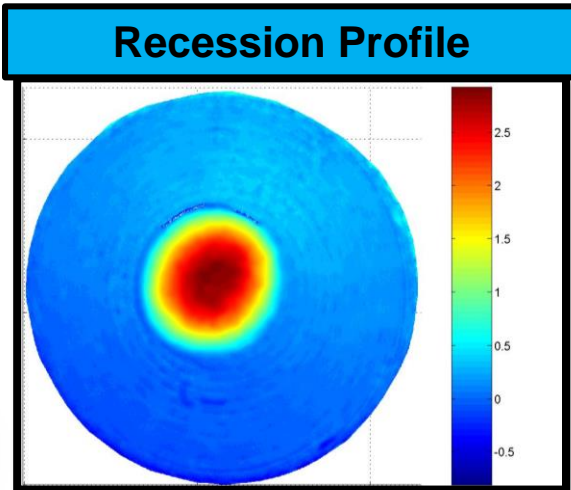

- Test articles show virtually no recession until coating begins to degrade.

- Laser scan reveals differential recession as evidenced by shallow pit (image on left).

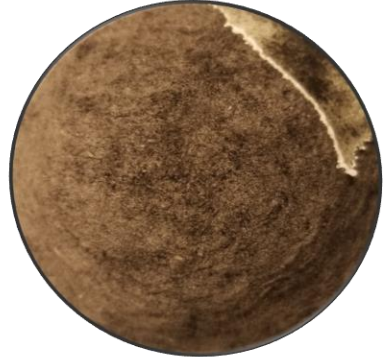
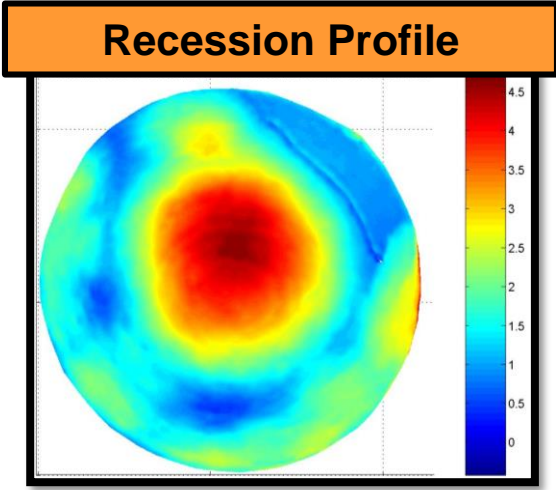

Asymmetric recession of TPS surface.

HyMETS Test Conditions

Atmosphere: Air
Heat Flux: ~ 140 W/cm²
Test length: 30 Seconds

- Unconfined differential recession at conditions of higher heat flux (image on right).

HyMETS Test Conditions

Atmosphere: Air
Heat Flux: ~ 224 W/cm²
Test length: 29 Seconds

Stakeholders



Entry Systems Modelling Project Management (ESM)

- M. Barnhardt, M. Wright, A. Brandis, M. Hughes

NASA ARC TSM / Material properties, model development, coating development

- T. Boghuzian, J. Garcia, G. Gonzales, F. Milos, M. Stackpoole, M. Switzer, N. Carder, S. White, J. Monk

MEDLI2, Mars 2020 / MEDLI2 Analysis and Reconstruction

- T. White, R. Beck, H. Wang

LaRC / HyMETS Testing

- S. Splinter, J. Gragg, B. Butler

NASA PMM / High-fidelity model development

- N. Mansour, J. Meurisse, J. Thornton, A. Borner, A. Fagnani, J. Ferguson, F. Semeraro

University of Illinois Urbana-Champaign and ALS / Permeability and Micro-CT Experiments

- Prof. Francesco Panerai, D. Parkinson, H. Barnard

Montana State University / Oxidation Studies of NuSil and FiberForm

- Prof. Timothy K. Minton, David Chen

University of Vermont / Gas-Surface Interaction Problems for Atmospheric Entry

- Prof. Douglas Fletcher

SRI International / Pyrolysis Studies of PICA and NuSil

- J. White

End

Questions