

ISSS 2019

NASA's Near Earth Asteroid Scout Mission Status, History, and Lesson's Learned

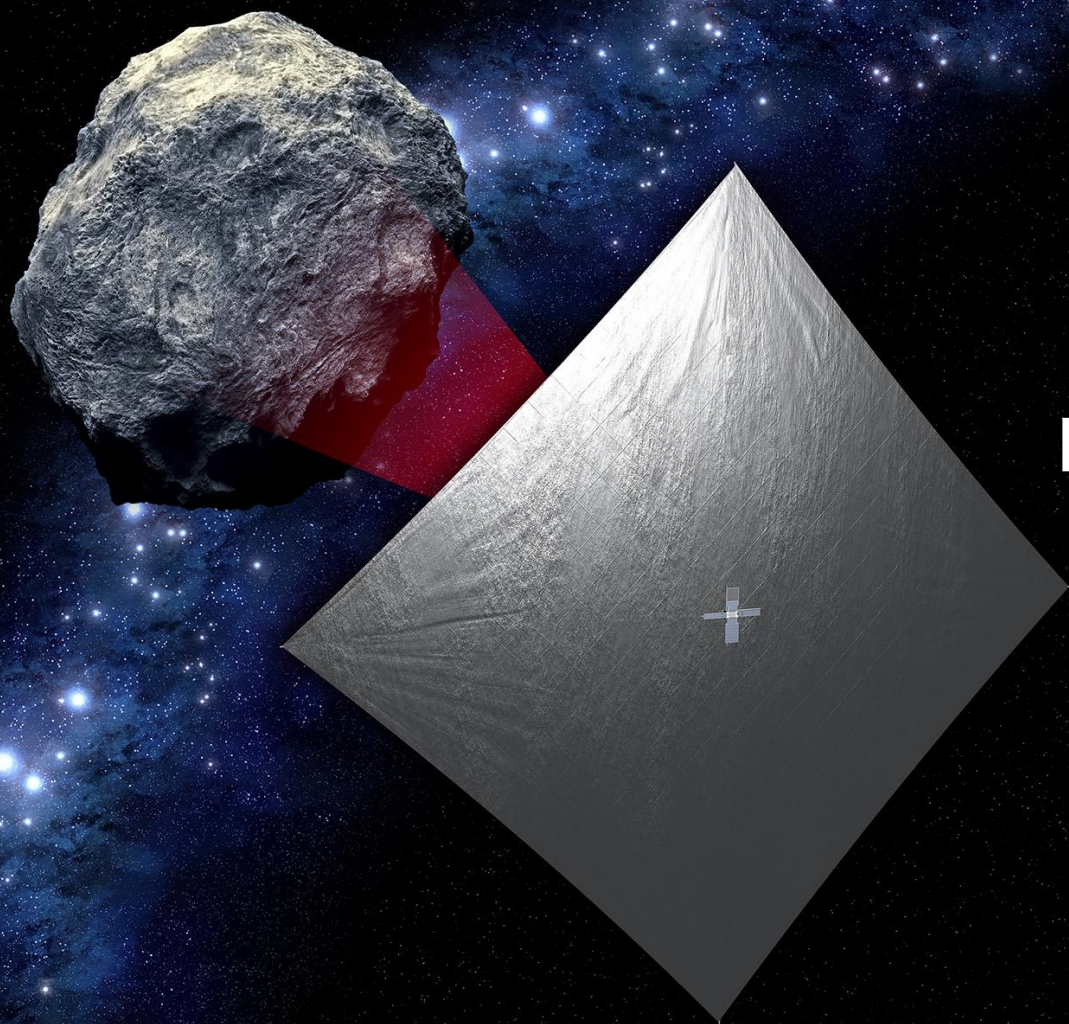

Les Johnson, Tiffany Lockett, and Joe Matus

NASA George C. Marshall Space Flight Center
Science and Technology Office

GOALS

- Characterize one candidate NEA with an imager to address key Strategic Knowledge Gaps (SKGs) for Human Exploration
- Demonstrate low cost capability for NEA detection and reconnaissance
- *(And fly a solar sail in interplanetary space!)*

Measurements: *NEA volume, spectral type, spin and orbital properties, address key physical and regolith mechanical SKGs*

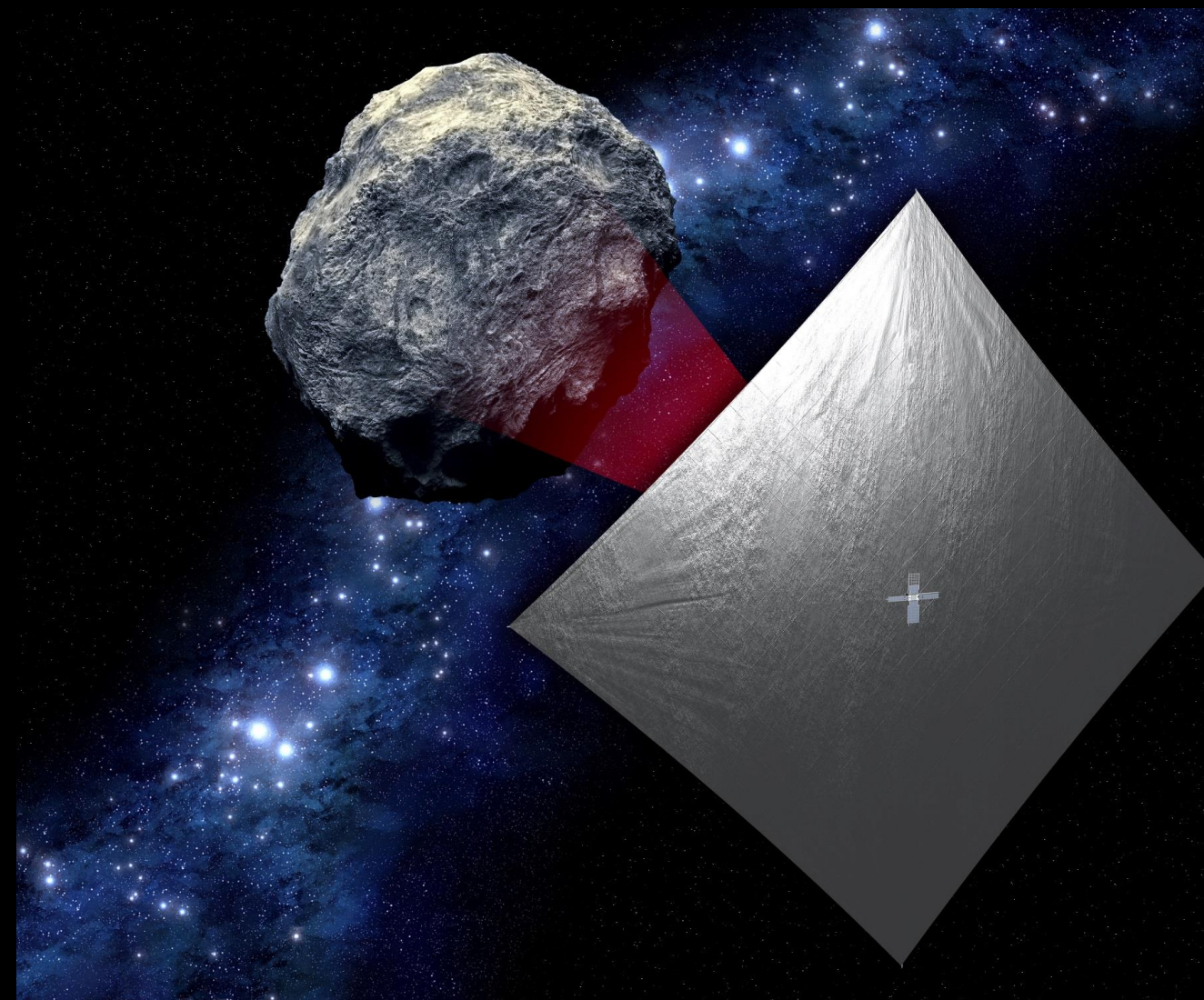

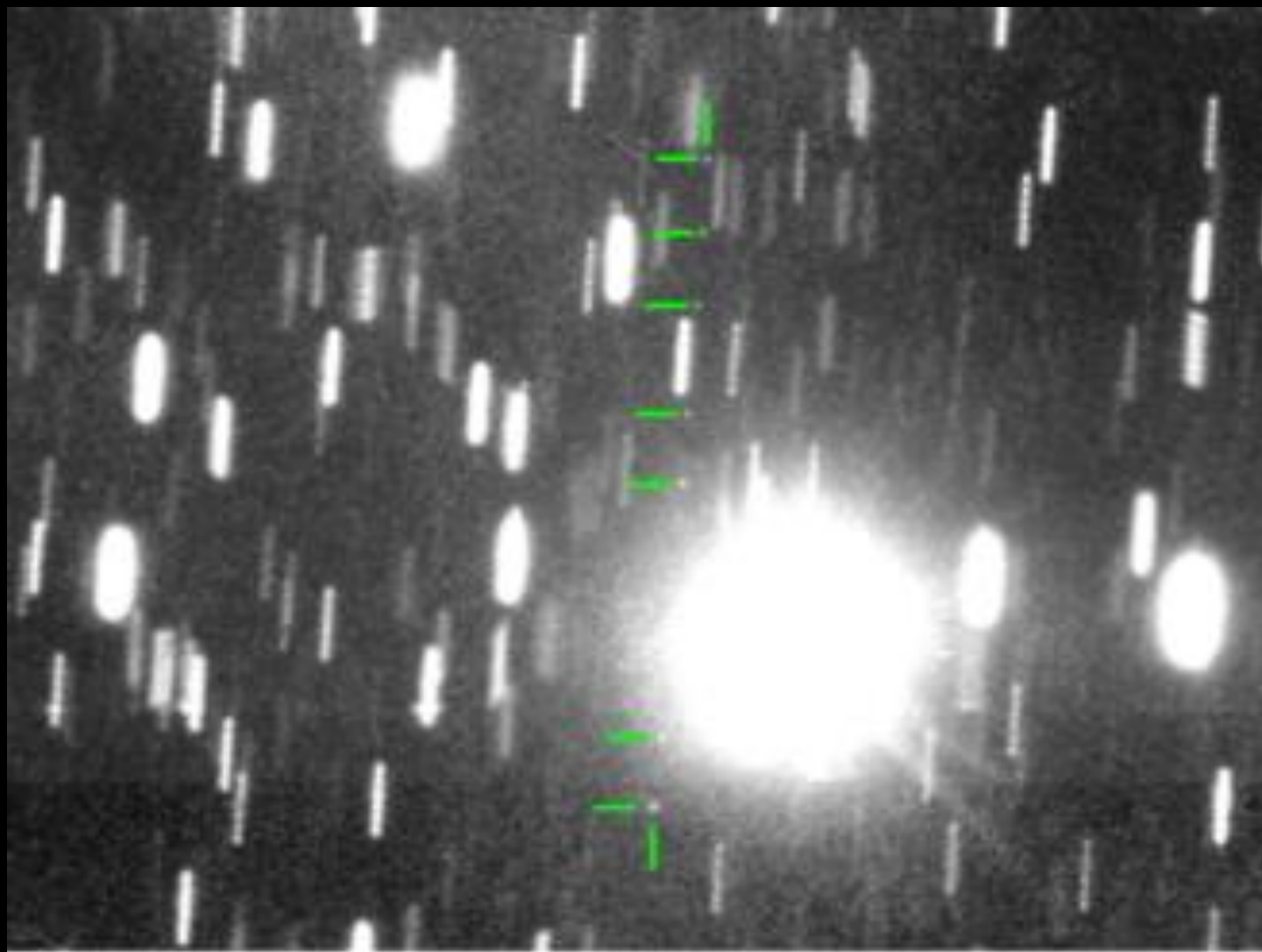

- Diameter ~ 5 -12 meters
- Rotation period between a few minutes and less than 1 hour
- Unlikely to have a companion
- Unlikely to retain an exosphere or dust cloud
 - Solar radiation pressure sweeps dust on timescales of hours or day

Near-Earth Asteroid 1991VG (marked with green lines) on 2017 May 30. This is a composite of 7 images obtained with the ESO VLT. These images have been combined, tracking the position of the asteroid. The stars appear trailed due to the motion of the asteroid during each series.

Credit Hainaut/Micheli/Koschny

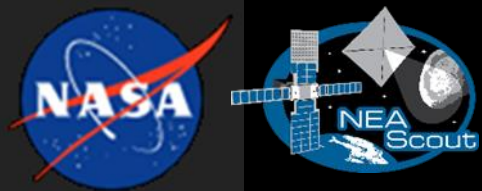

NEA Scout Launch



ISSAS 2019

NEA Scout is one of 13 secondary payloads launching on SLS EM-1

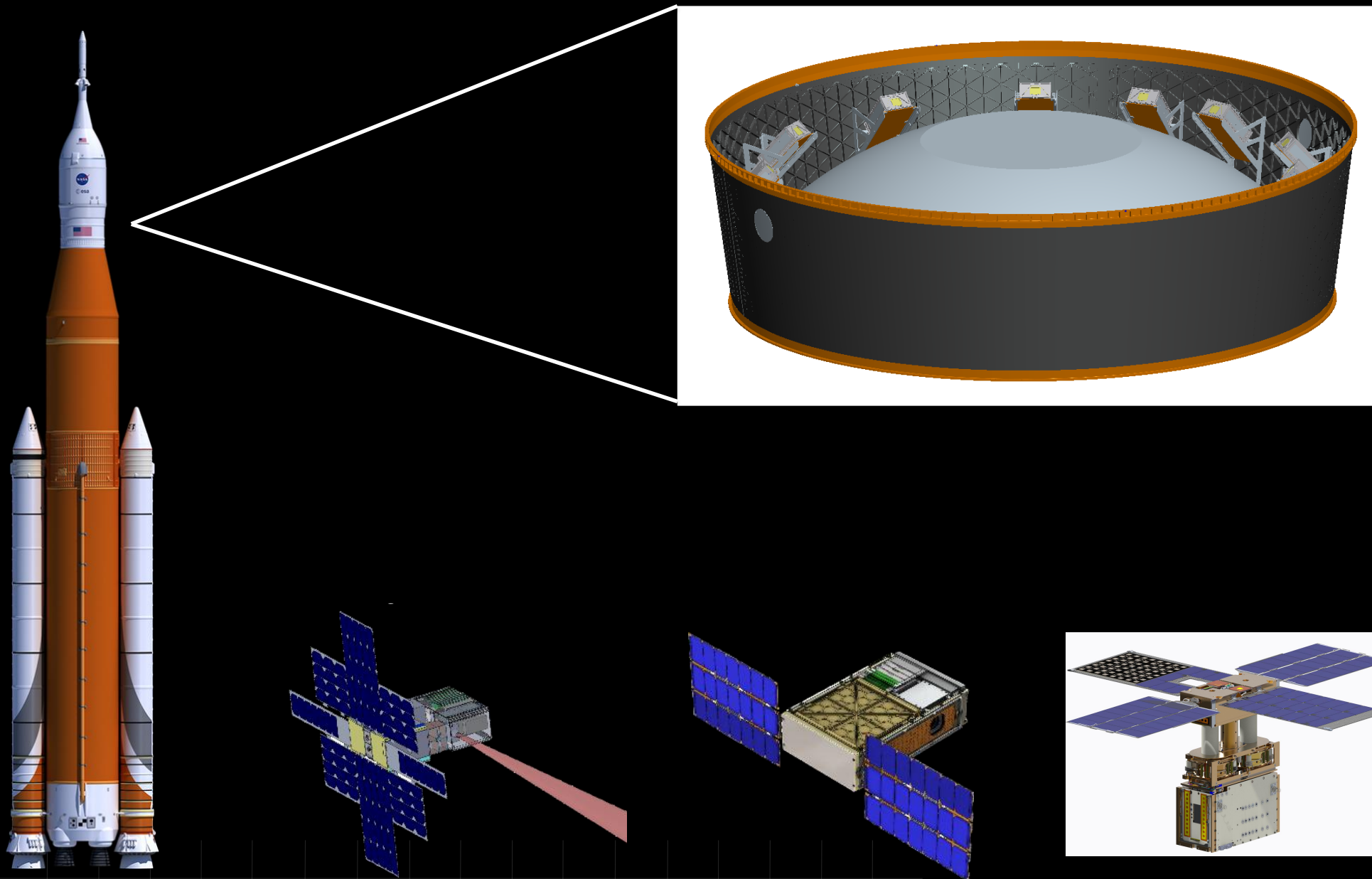

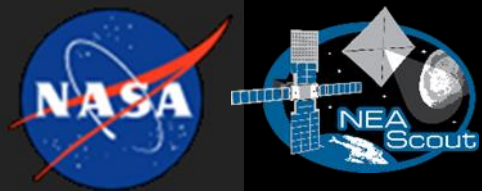

NEA Scout Spacecraft



ISSS 2019

NEA Scout is an interplanetary spacecraft stuffed into a 6U cubesat

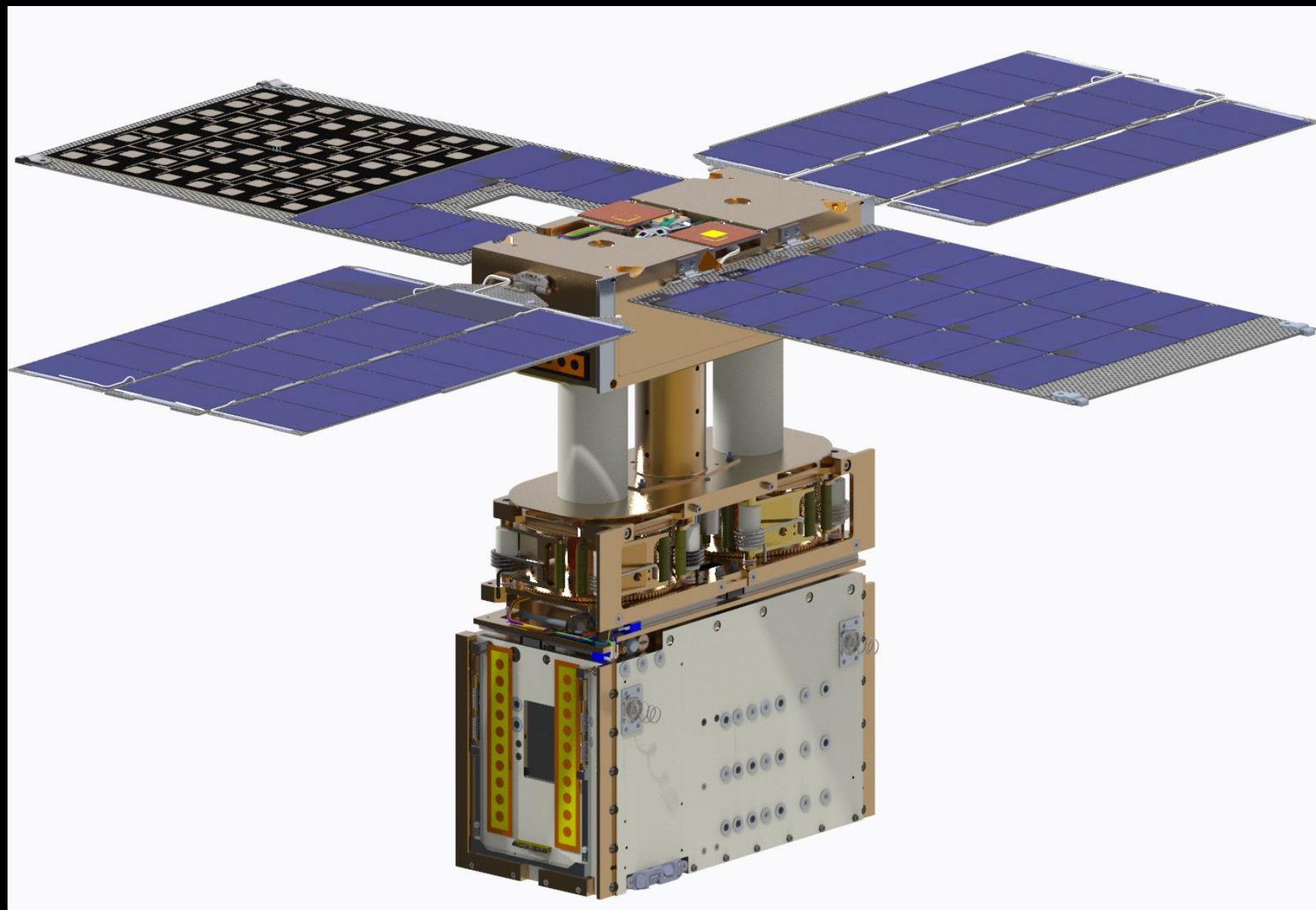



6U Cubesat Form Factor: 30 x 20 x 10 cm



ISSS 2019

“Most difficult game of Tetris ever played”

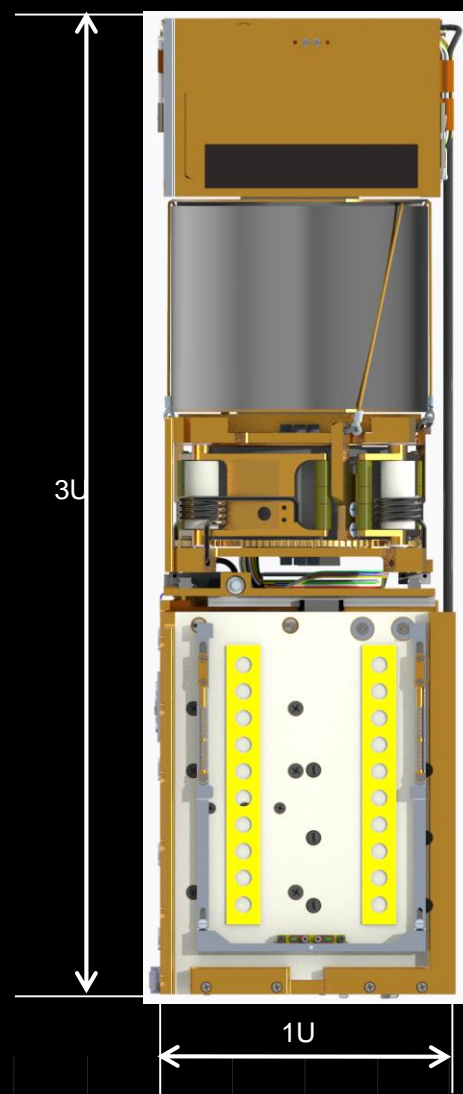

RCS System

Spoiled Sails

Boom Deployers

Avionics/Science

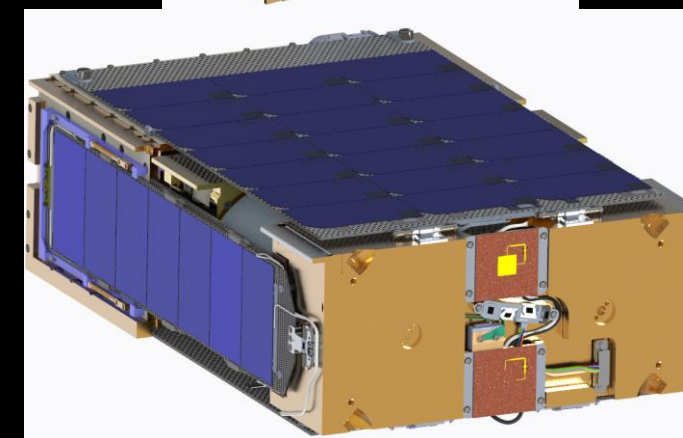
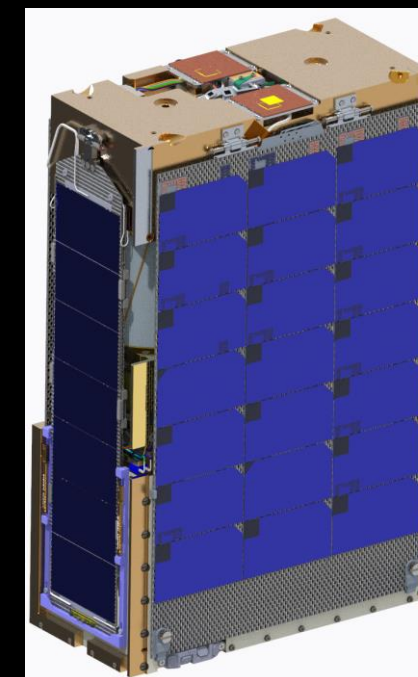
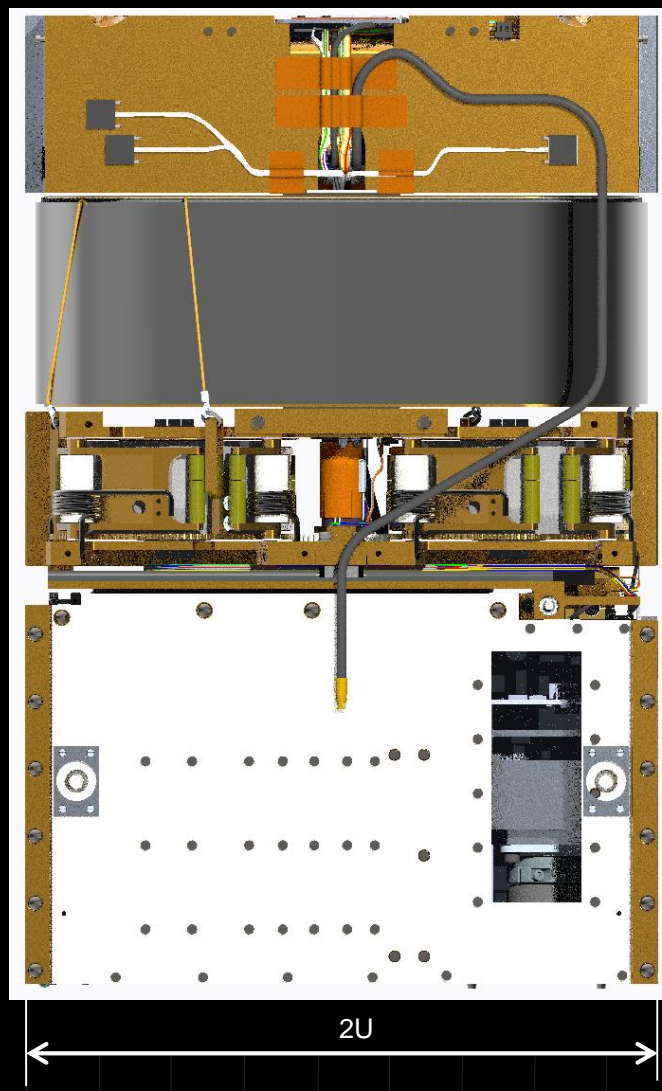

A fully functional planetary spacecraft in a shoebox

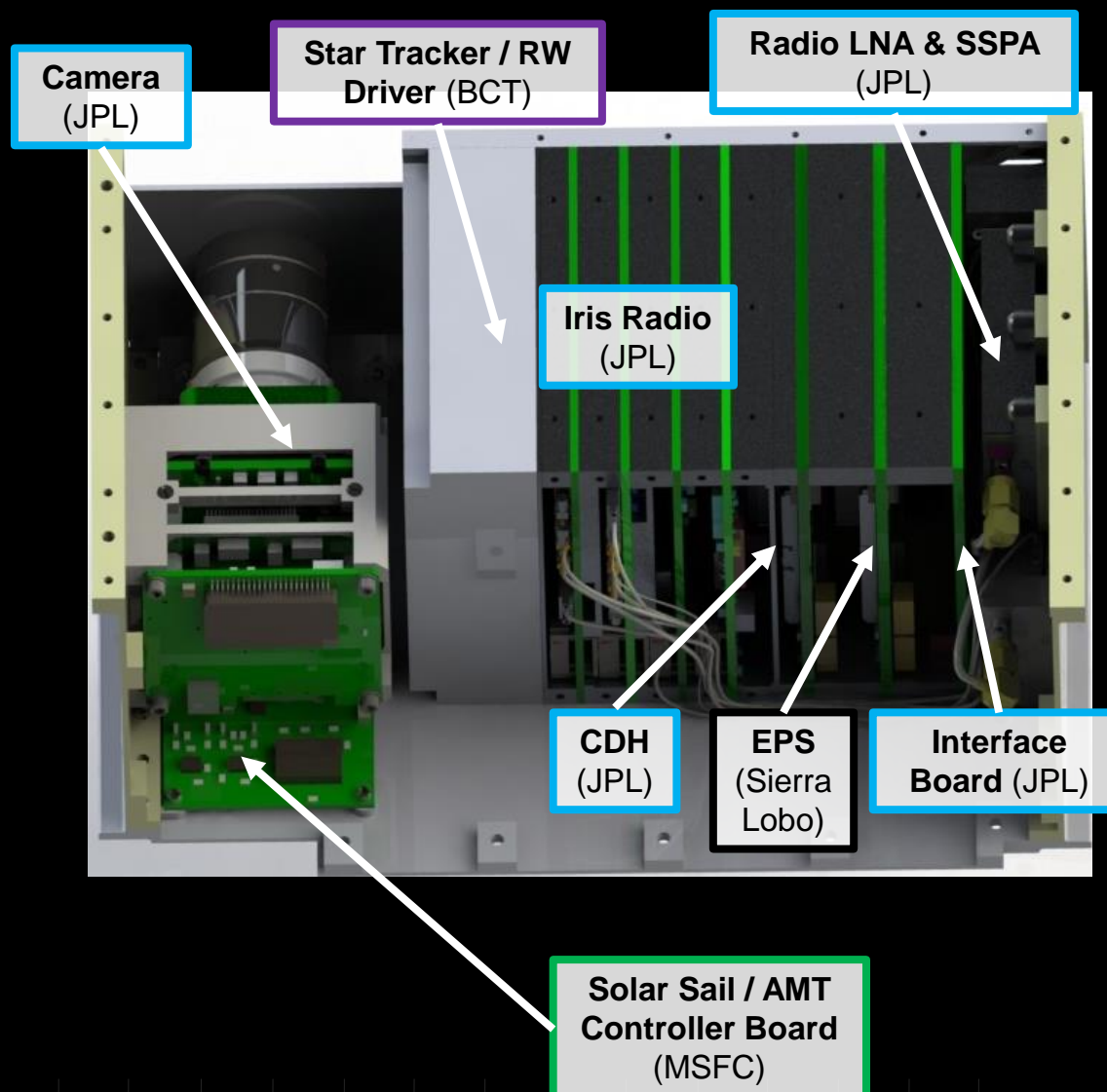

A fully functional planetary spacecraft in a shoebox

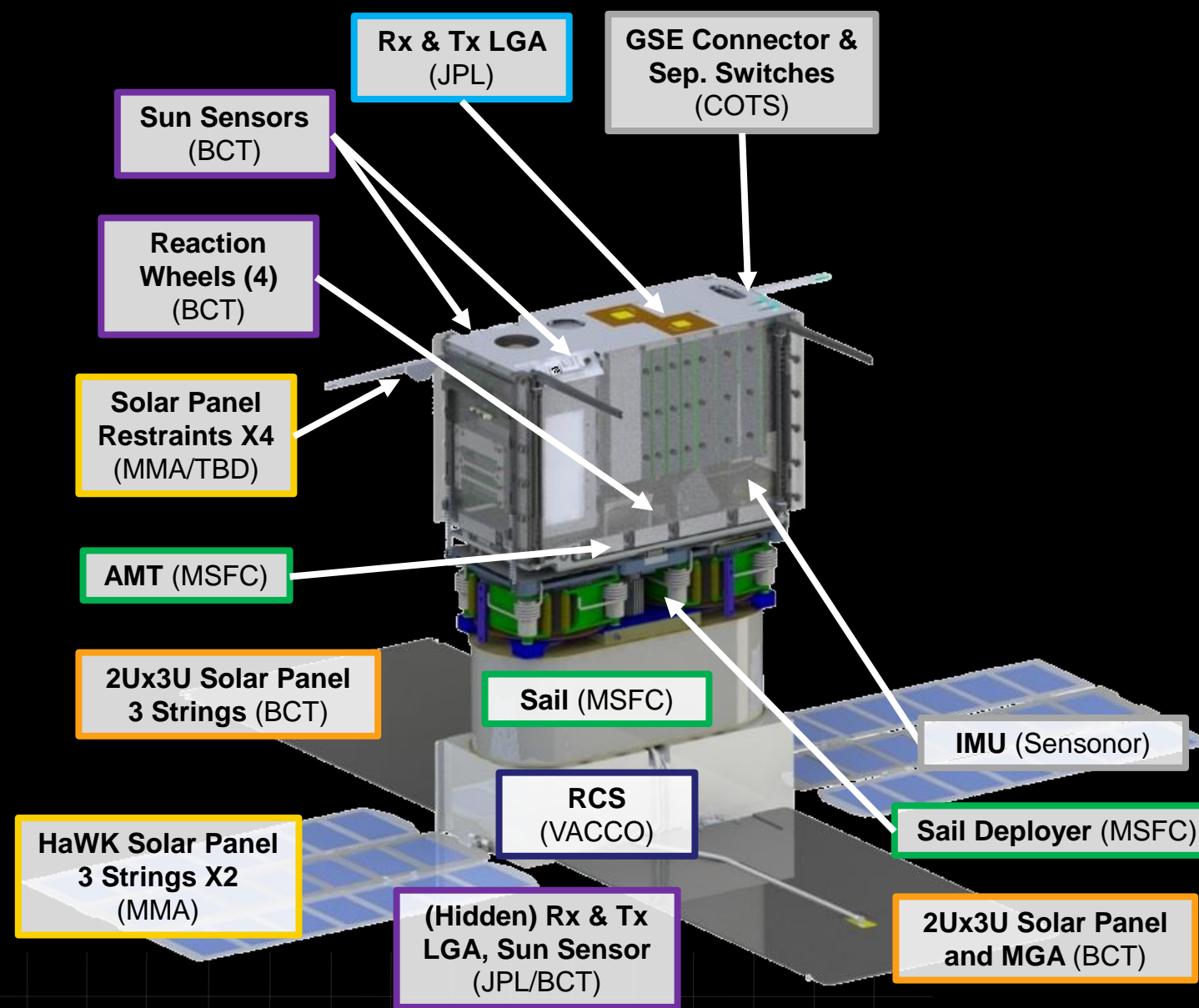

Stowed in Dispenser

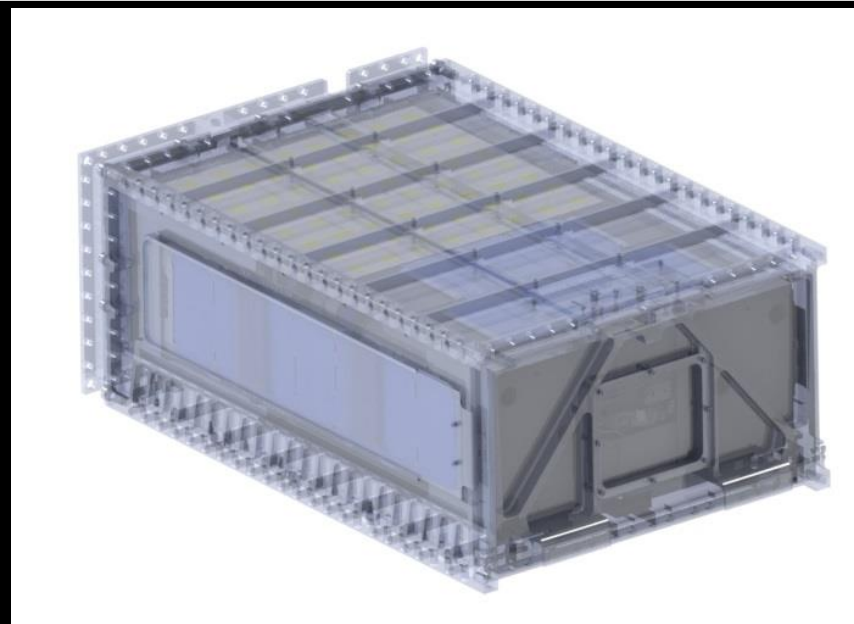

Configuration before sail deployment

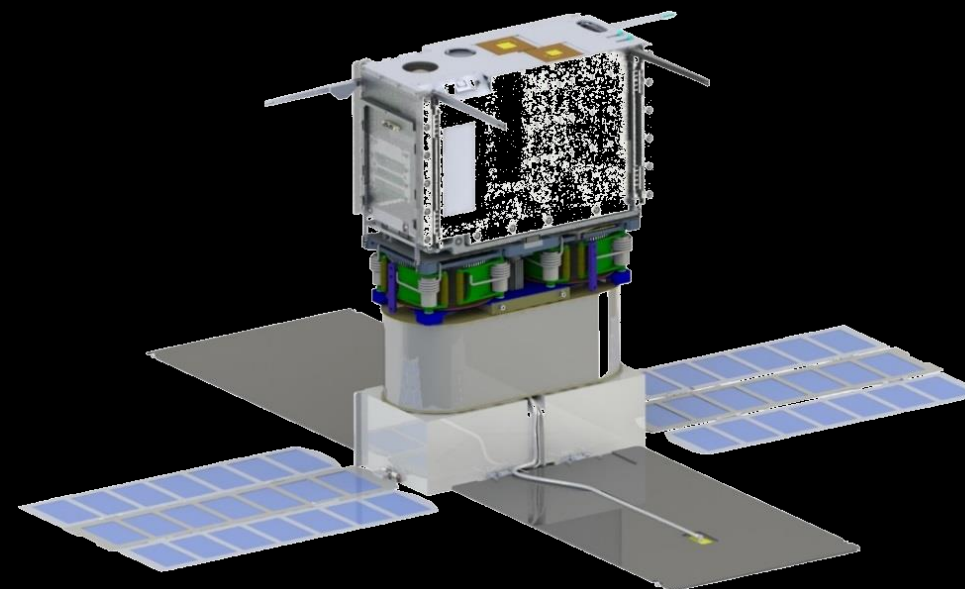

Ejection, before panel deployments

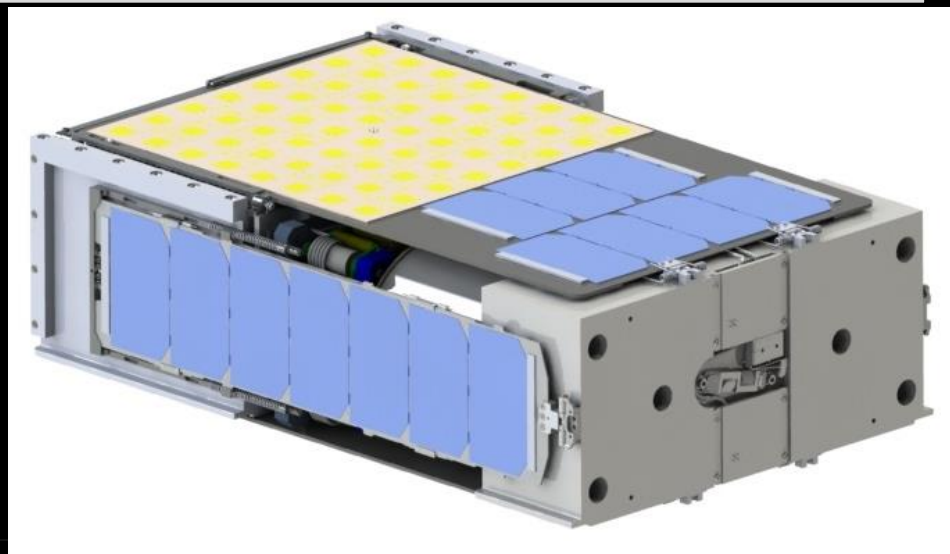

Sail deployed

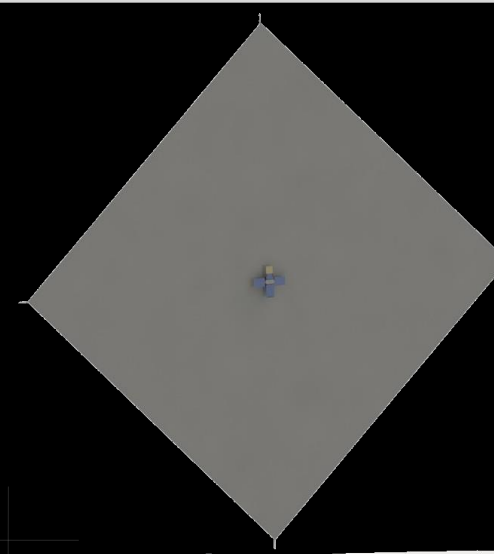



~9 x ~9m Solar Sail



ISSS 2019

Deployed Solar Sail

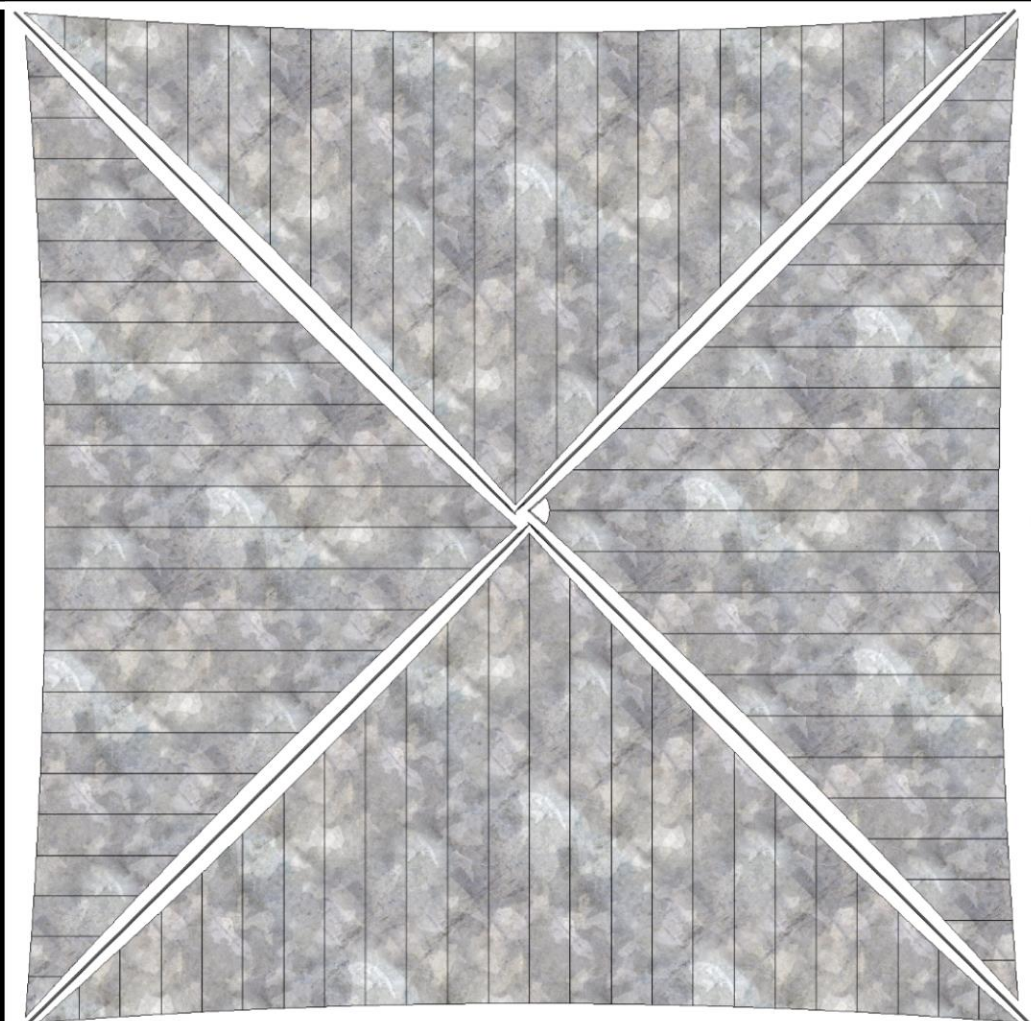

School Bus



6U
Stowed
Flight
System



Folded, spooled and packaged in here

86m² Sail in <2U

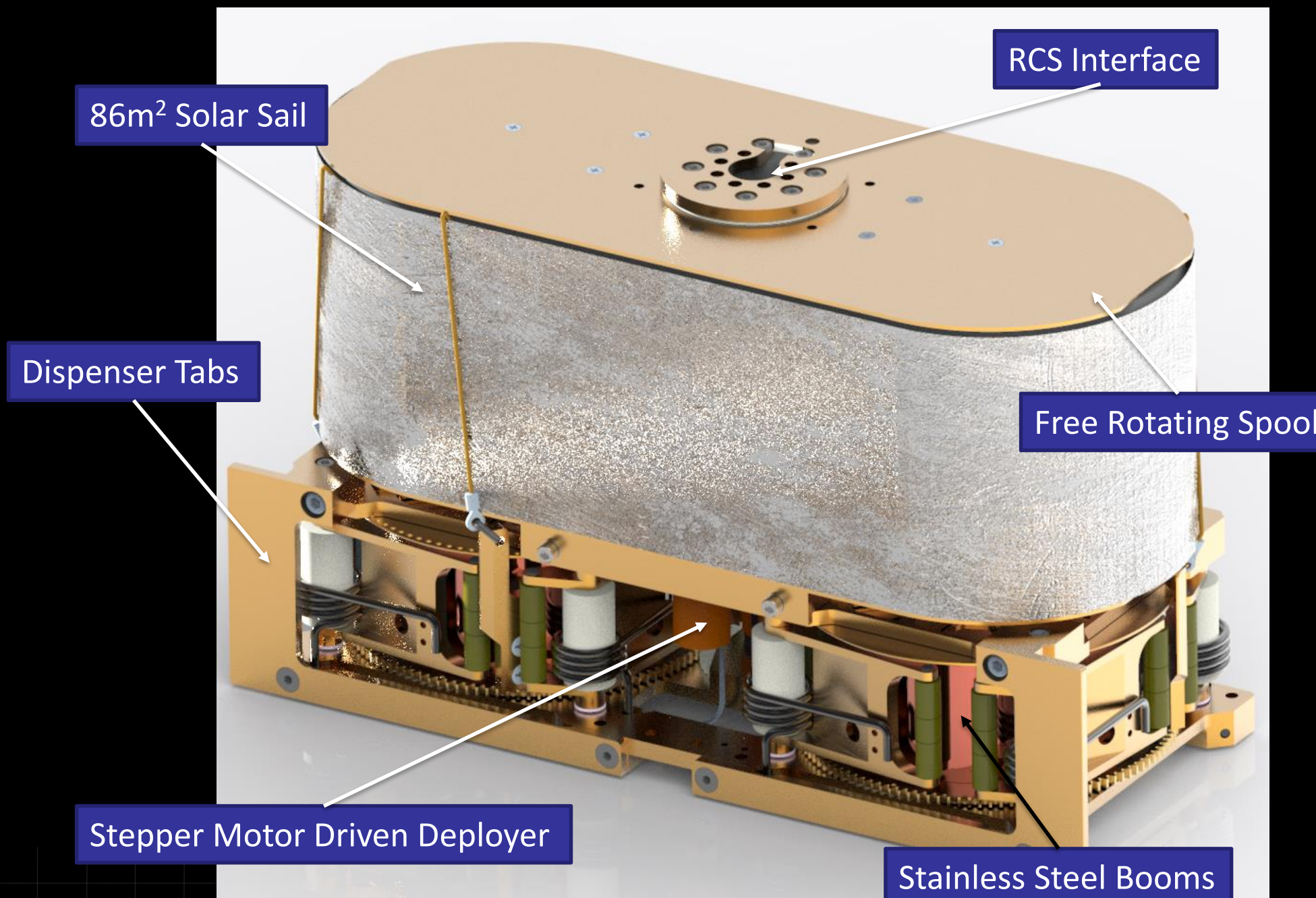

Full Scale Sail Assembly

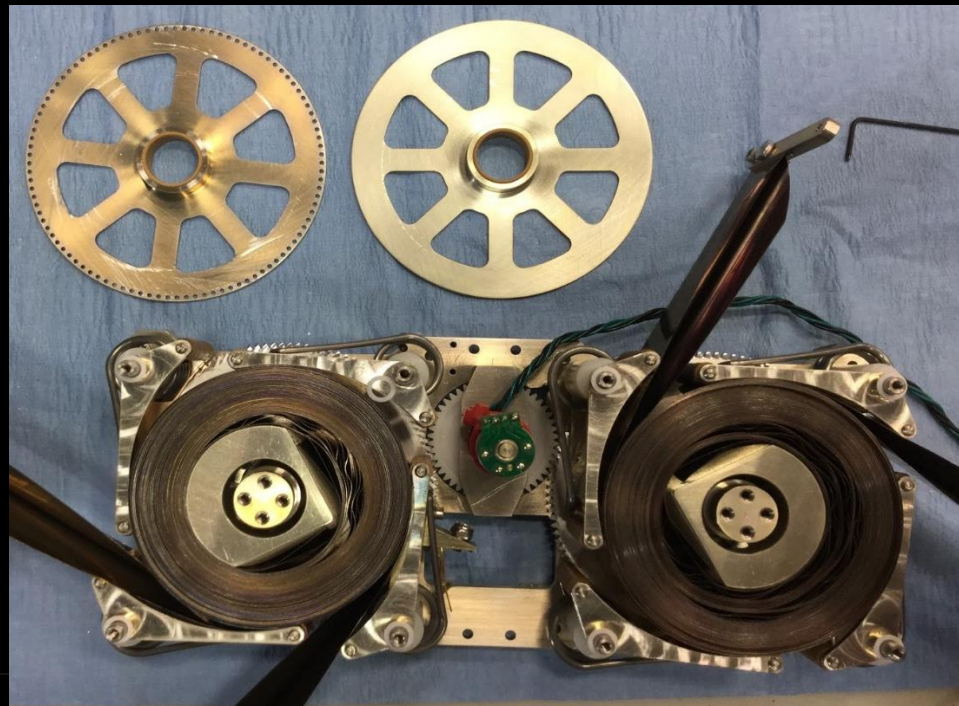
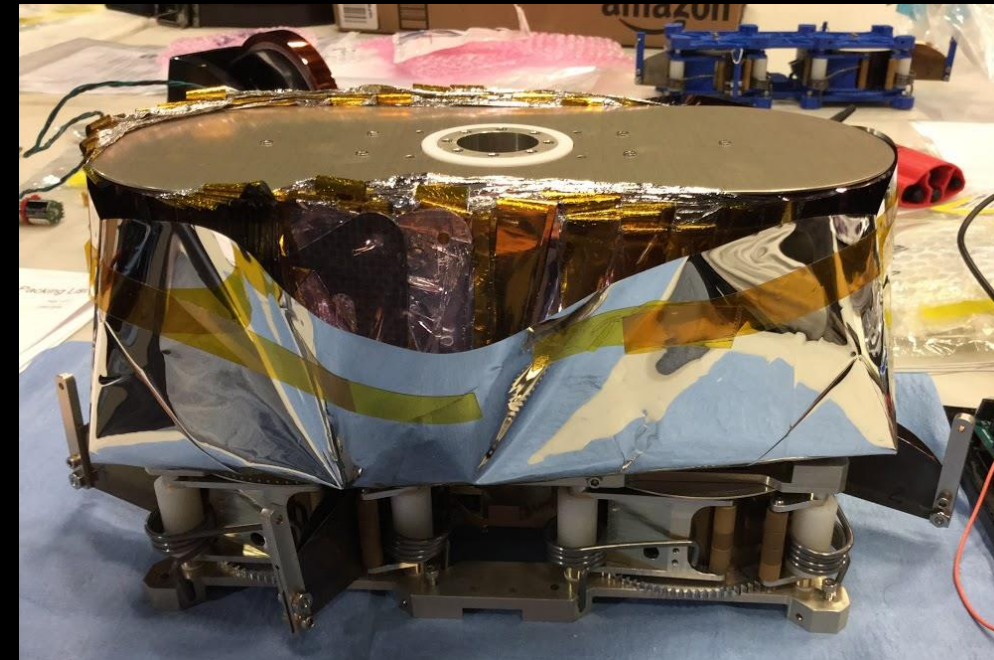
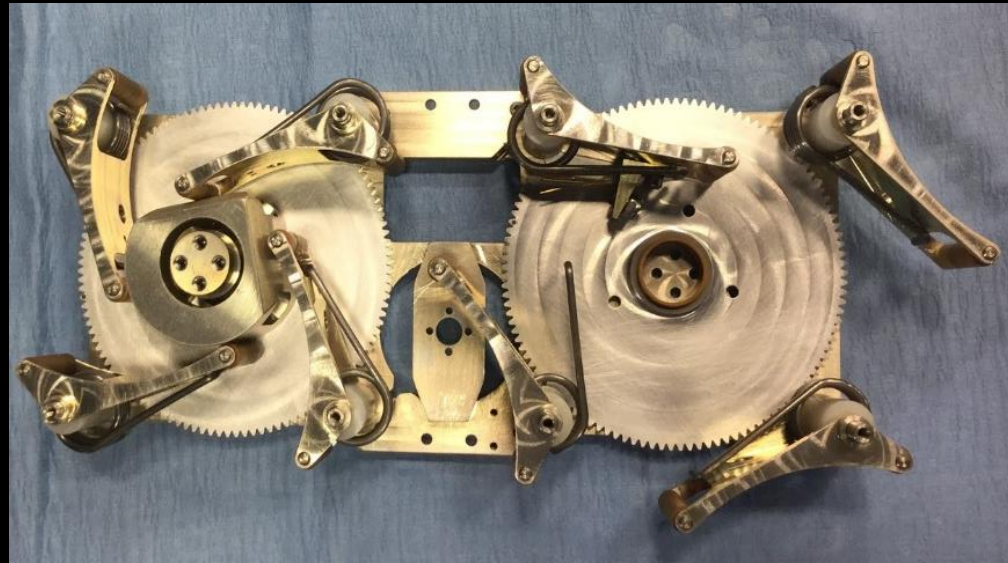

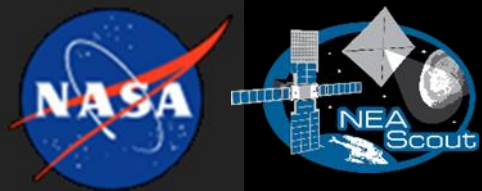

Flight Sail Testing



ISSS 2019



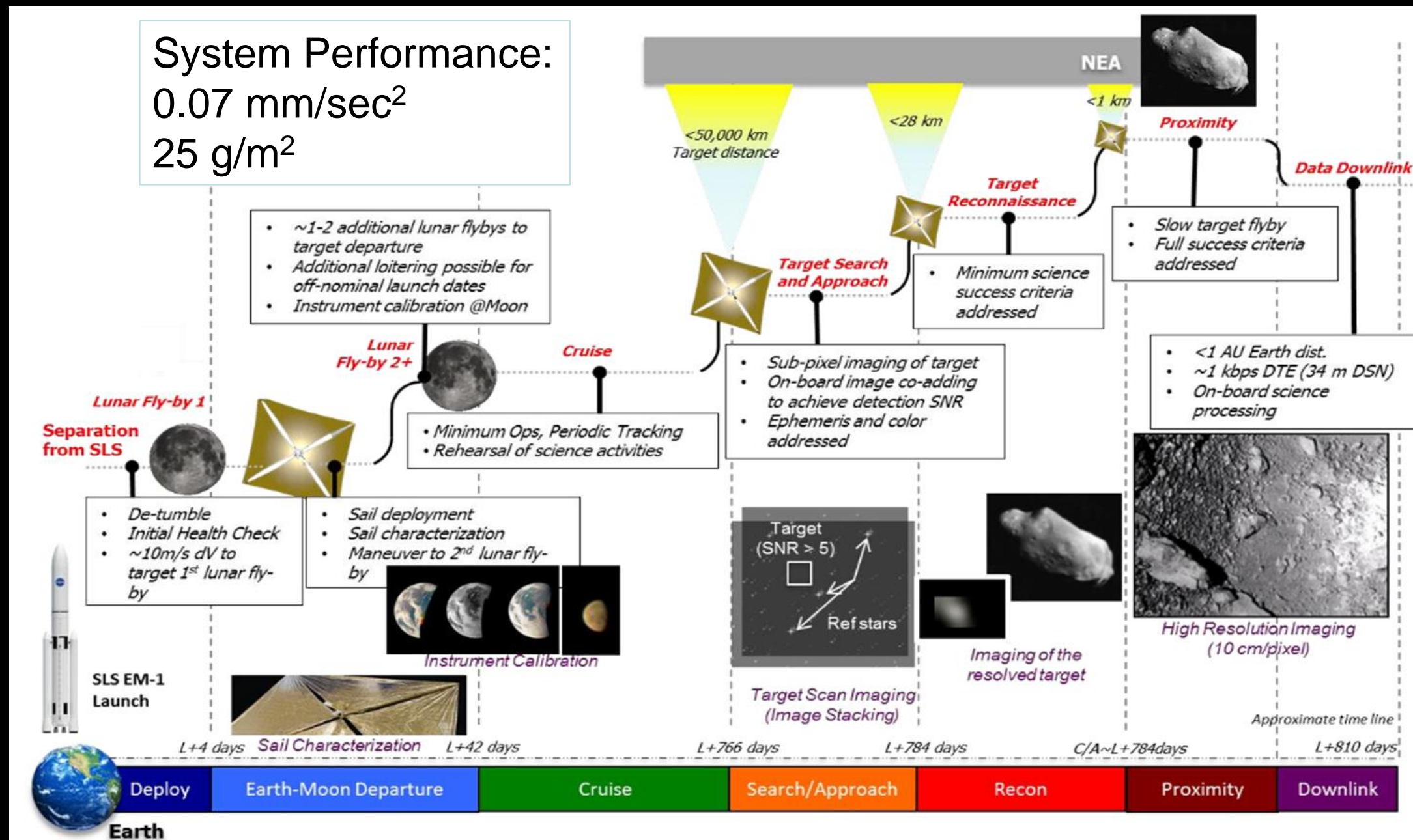

- 2010
 - Multiple Near Earth Object Rendezvous Using Solar Sails
 - 5000 square meter solar sail
 - Sail system mass = 71 kg
 - Total spacecraft mass = 340 kg
 - Estimated cost = \$91M

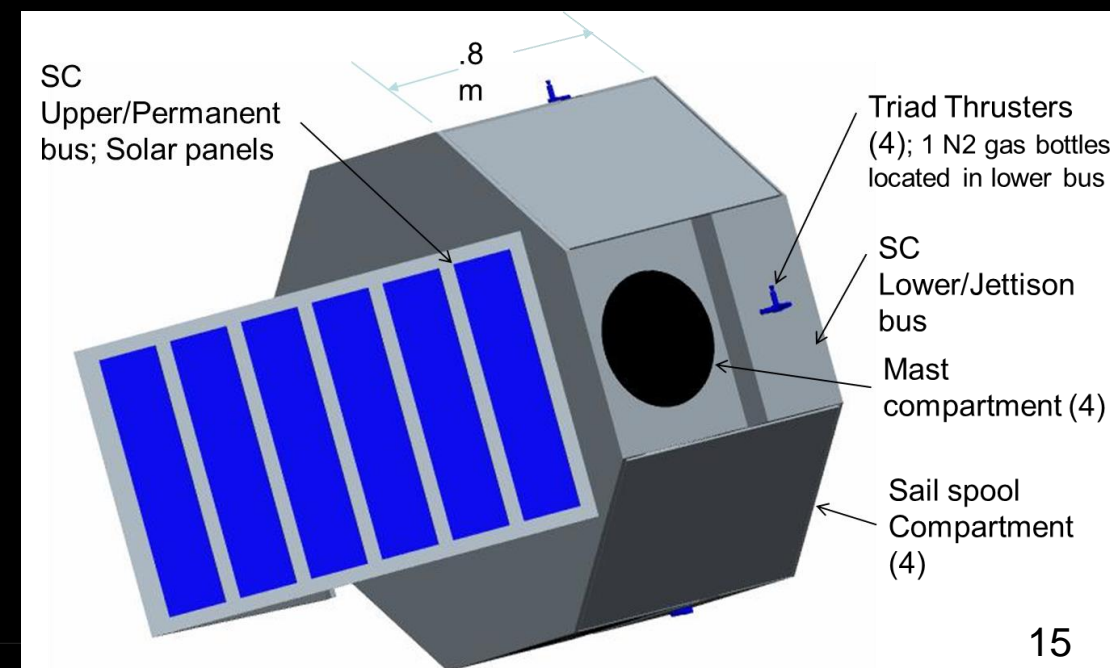
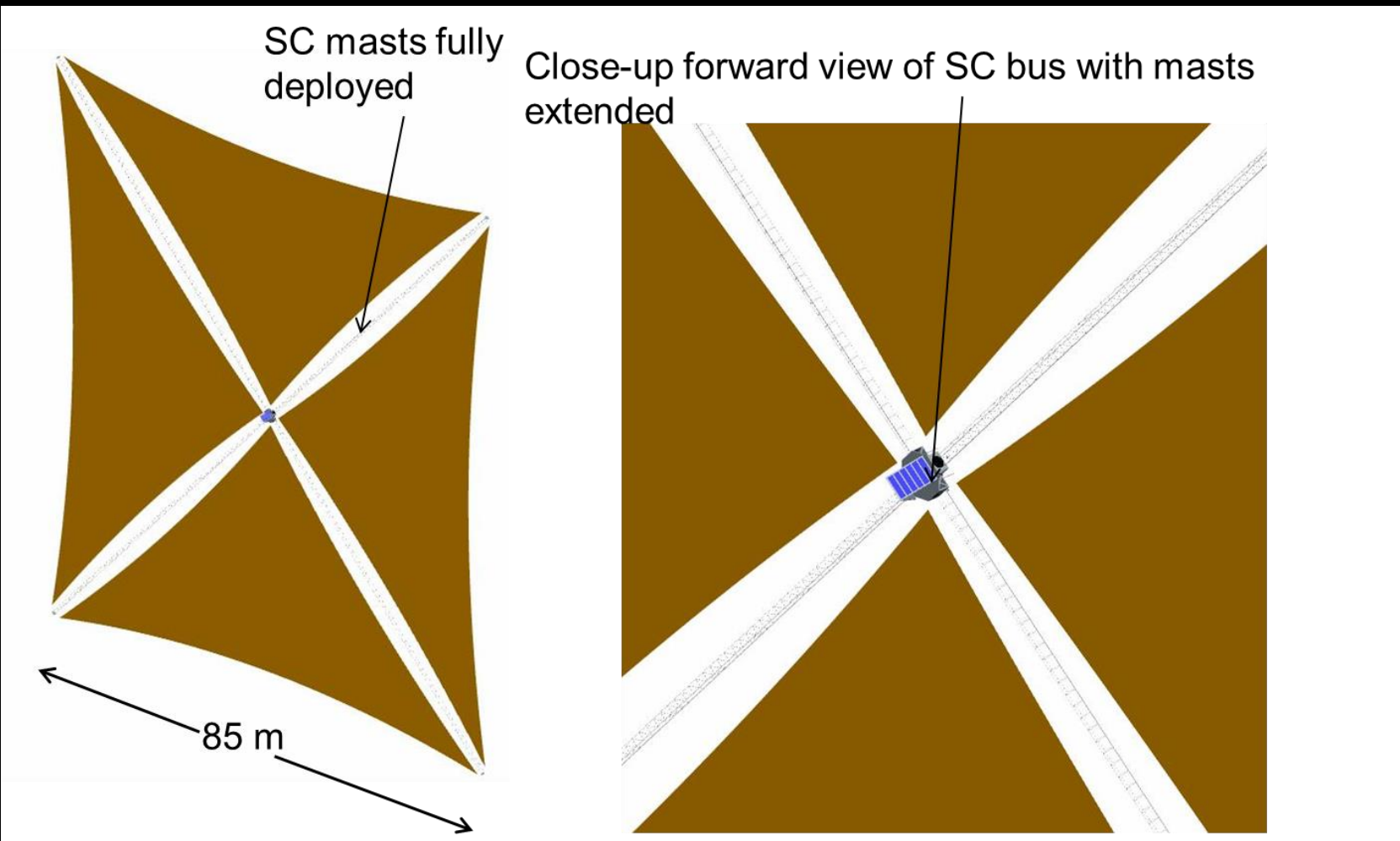

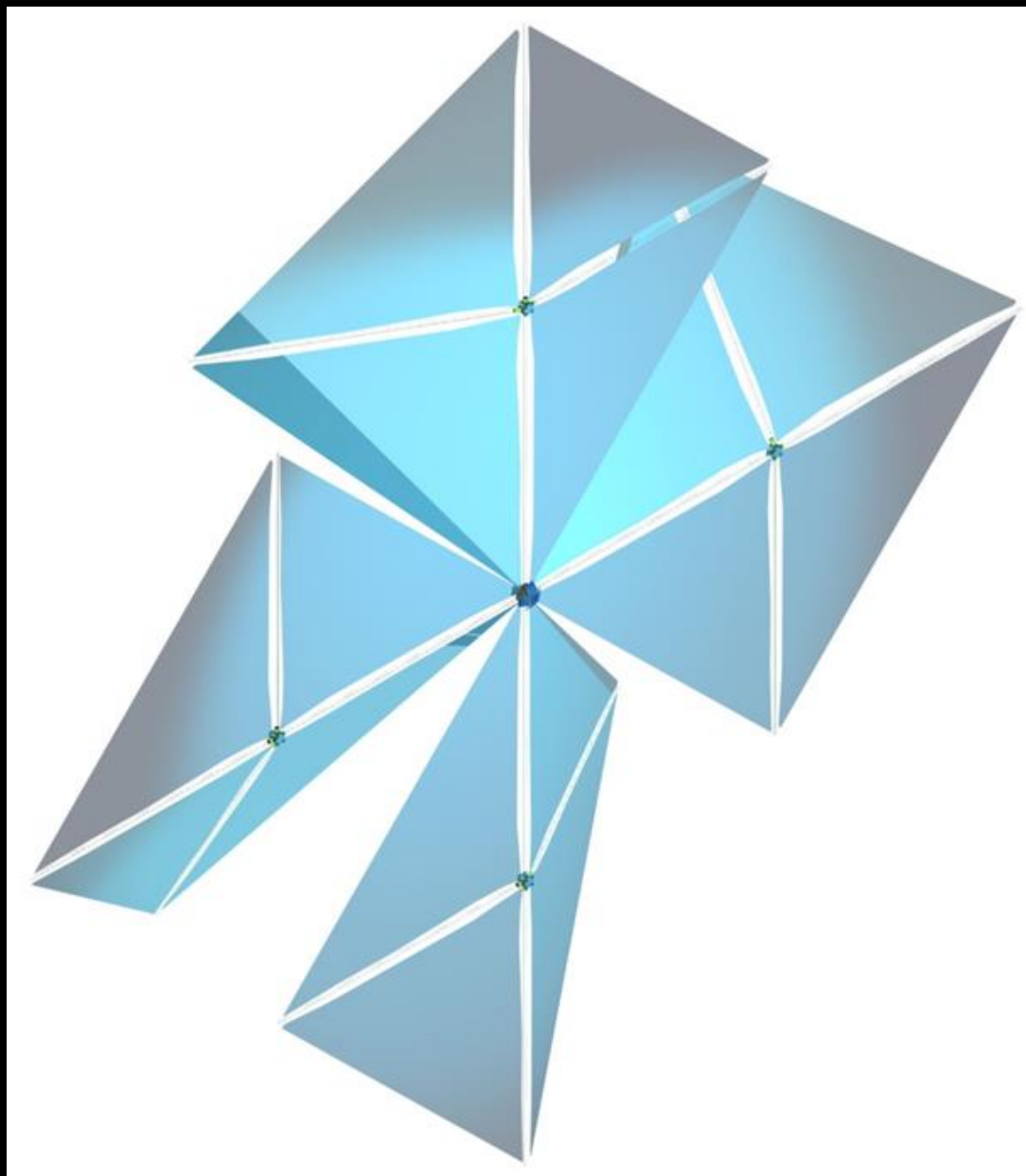

- 2012
 - Near Earth Object Precursor
 - 871 square meter solar sail
 - Sail system mass = 19 kg
 - Total spacecraft mass = 43 kg
 - Estimated cost = \$91M

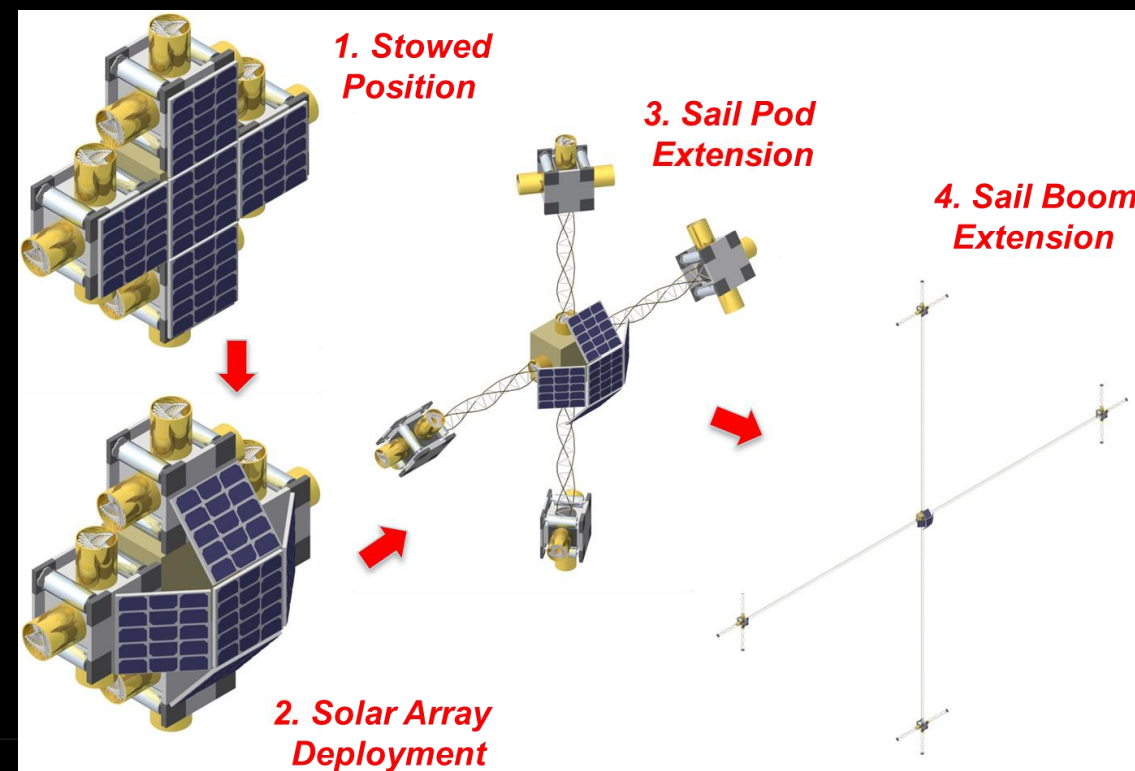

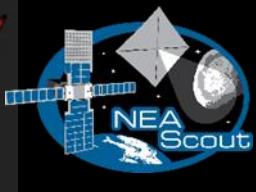

NEA Scout & Lunar Flashlight



ISSS 2019

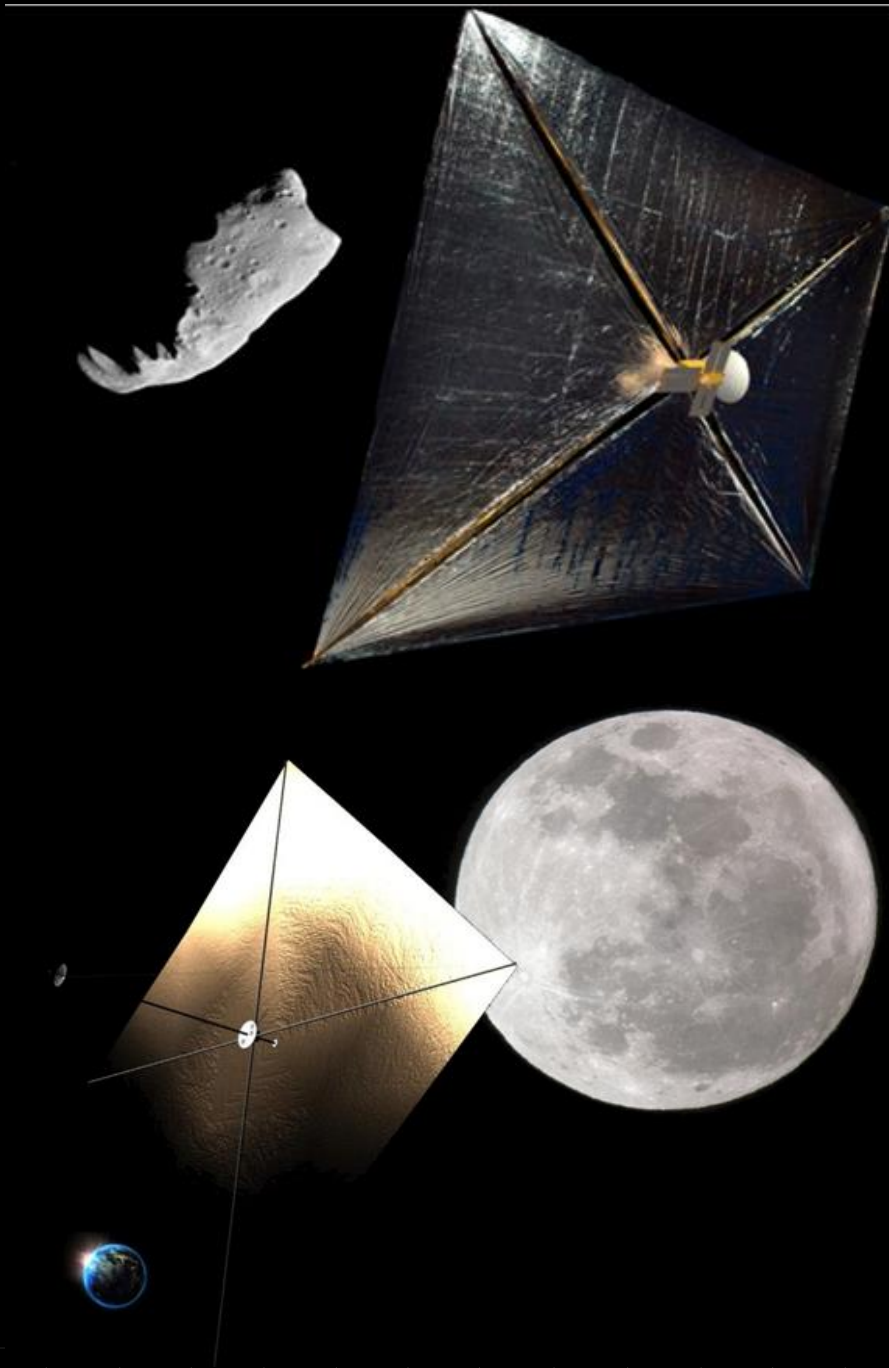

- 2013
 - Near Earth Asteroid Scout
 - >100 square meter solar sail
 - Sail system mass = ~4 kg
 - 12 U spacecraft bus
 - Total spacecraft mass = 30 kg
 - Estimated cost = \$25M
 - Proposal submitted to HEOMD
 - JPL proposed the same mission independently
 - JPL also proposed Lunar Flashlight – an additional solar sail mission
 - MSFC and JPL told to merge into a single team

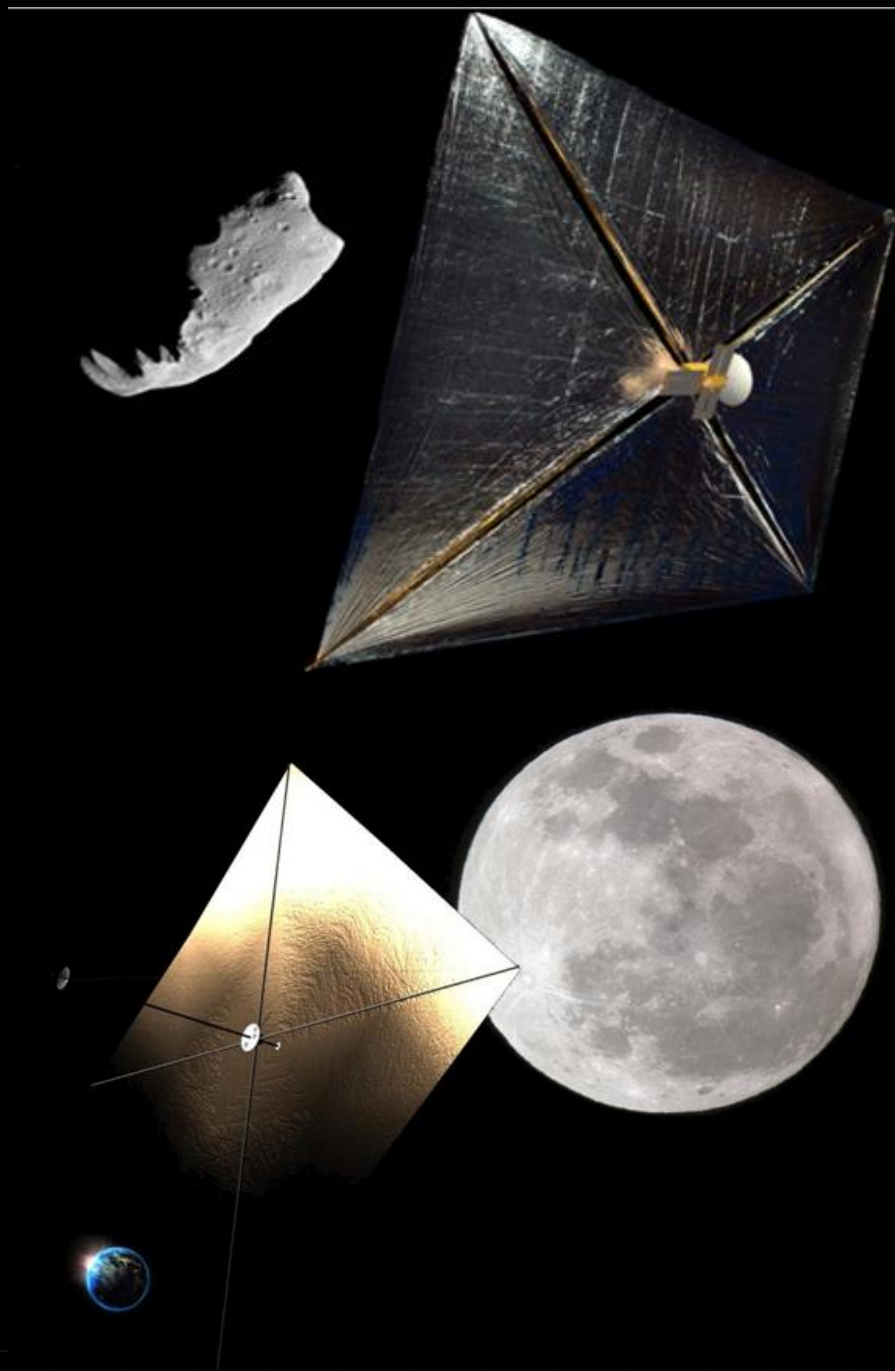

- 2013
 - Near Earth Asteroid Scout
 - 86 square meter solar sail
 - Sail system mass = <3 kg
 - 6 U spacecraft bus
 - Total spacecraft mass = ~24 kg
 - Estimated cost = \$23M
 - Same solar sail for both missions
 - MSFC develop the solar sail
 - JPL develop the spacecraft
 - MSFC manage NEA Scout
 - JPL manage Lunar Flashlight

- Commonality of sail design for NEA Scout and Lunar Flashlight will minimize development costs
 - Sail sized to meet propulsive requirements for both missions
 - Will additionally provide reflector for Lunar Flashlight science
 - Common elements include booms, materials, packaging, deployment and control systems
- Will seek commercial partner to license the sail technology for future NASA and commercial missions:
 - Exploration (additional NEA's)
 - Science (Planetary, Heliophysics)
 - Resource Identification (commercial)
- MSFC has Space Act Agreement with The Planetary Society for lessons learned on their LightSail Project

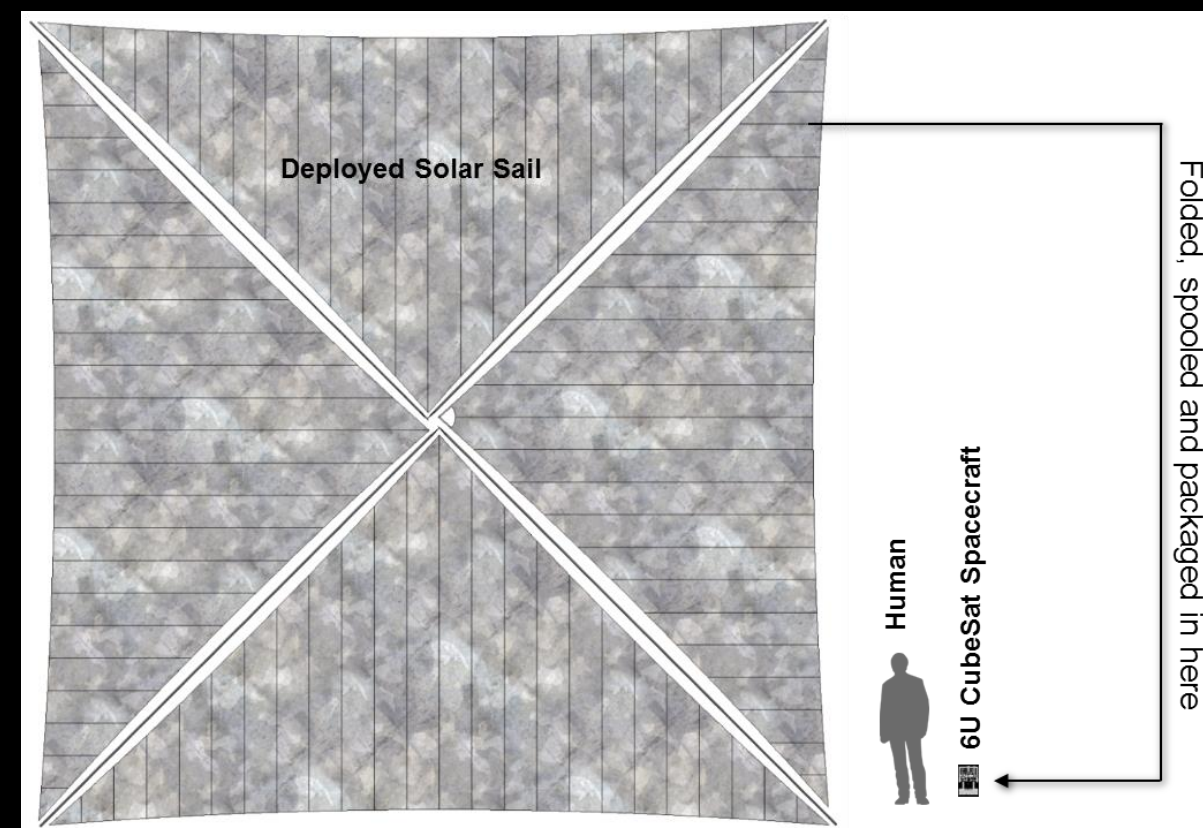

- Commonality of sail design for NEA Scout and Lunar Flashlight will minimize development costs
 - Sail sized to meet propulsive requirements for both missions
 - Will additionally provide reflective thermal protection for Lunar Flashlight
 - Common elements include deployment and control systems
- Will seek commercial partner to license the sail technology for future NASA and commercial missions
 - Exploration (additional NEA Scout)
 - Science (Planetary, Heliophysics)
 - Resource Identification (commercial)
- MSFC has Space Act Agreement with The Planetary Society for lessons learned on their LightSail Project

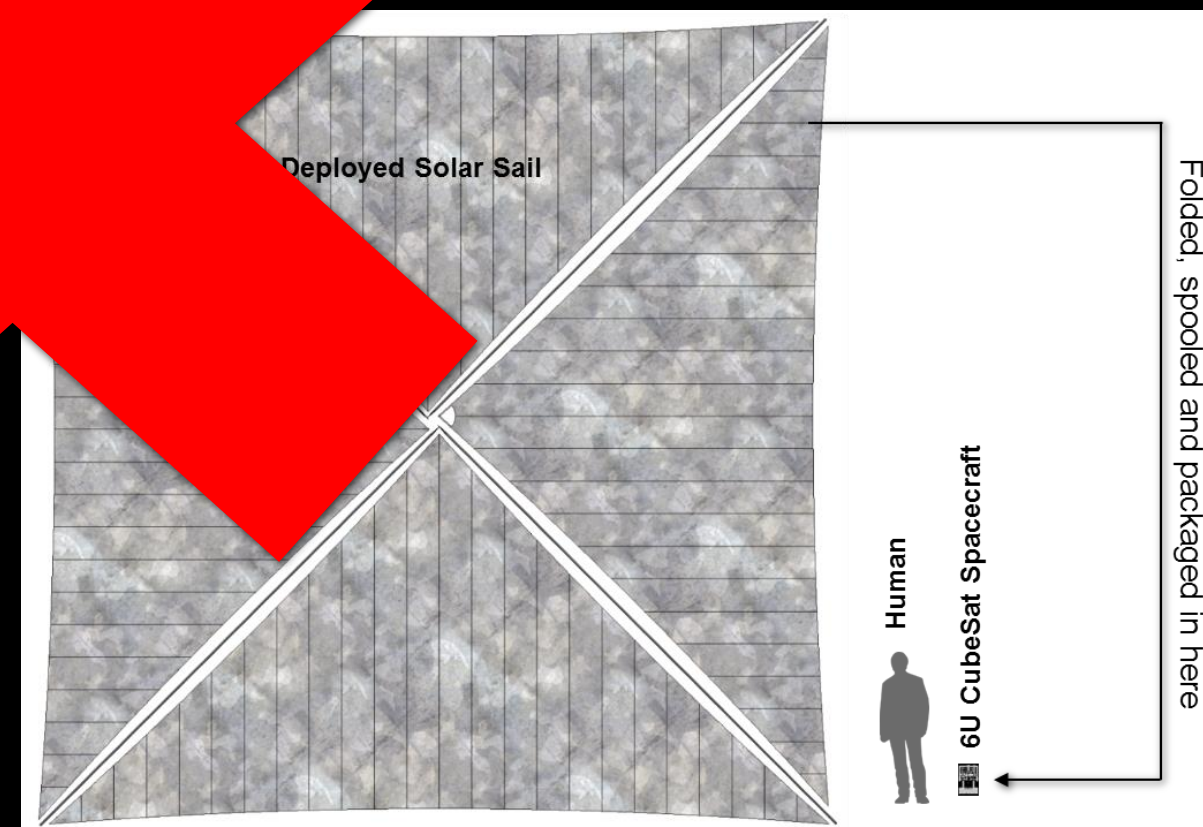

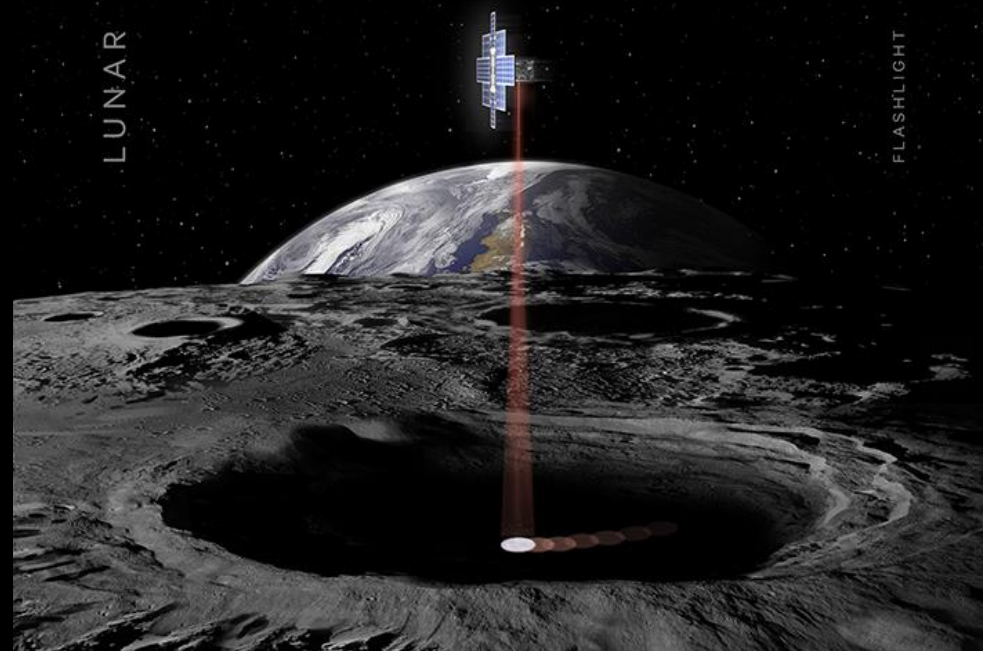

- 2015
 - Lunar Flashlight spacecraft became too heavy for a solar sail to provide sufficient propulsion
 - sail removed
 - Laser and chemical propulsion added

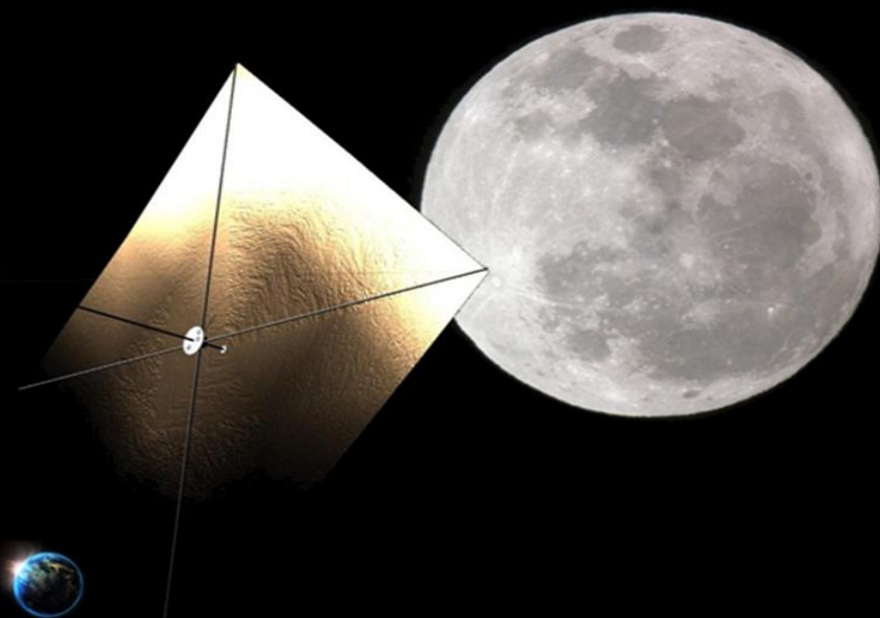

- NanoSail-D heritage 4-quadrant design with 4 metallic booms
- LaRC analysis showed that metallic booms would deform, destroying sail flatness

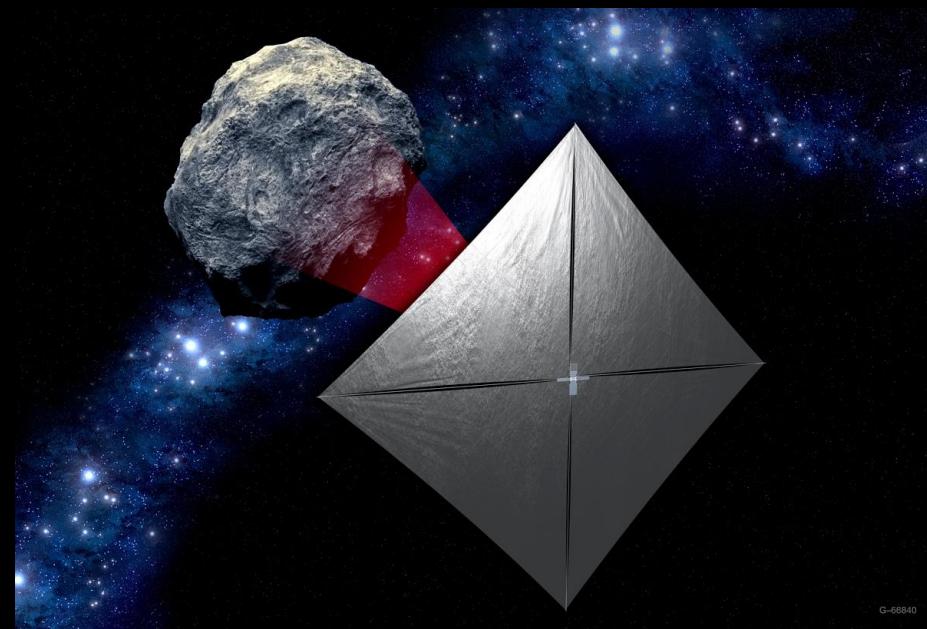

- Single sail developed to shade the booms and eliminate thermal deformation problems

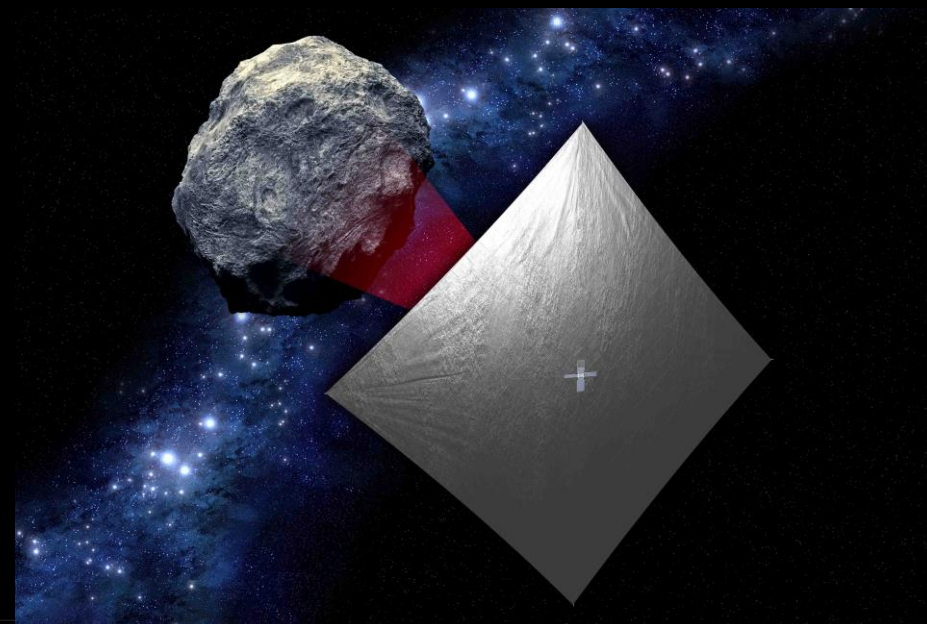

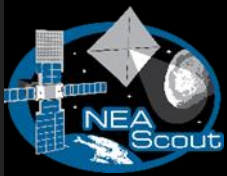

Ideal, Flat Solar Sails



ISSS 2019

Ideal sails are perfectly flat and have predictable and regular light reflection

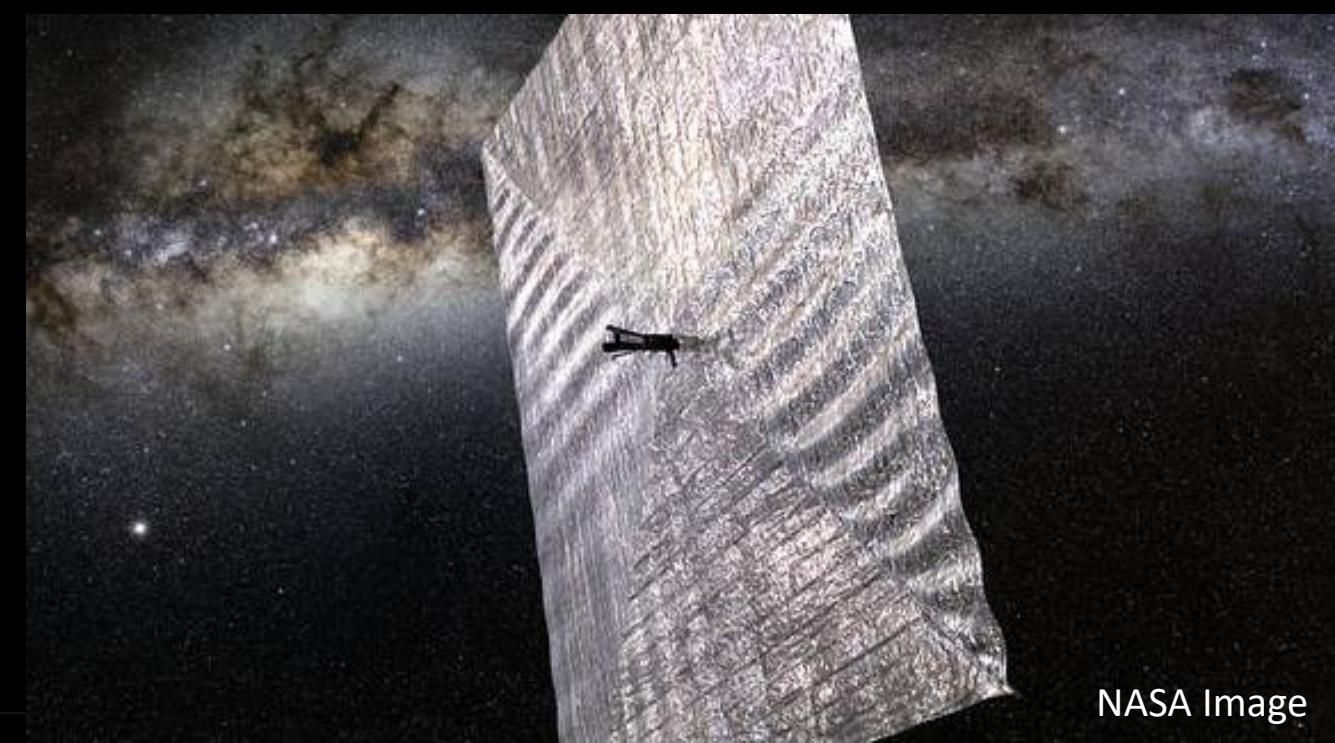
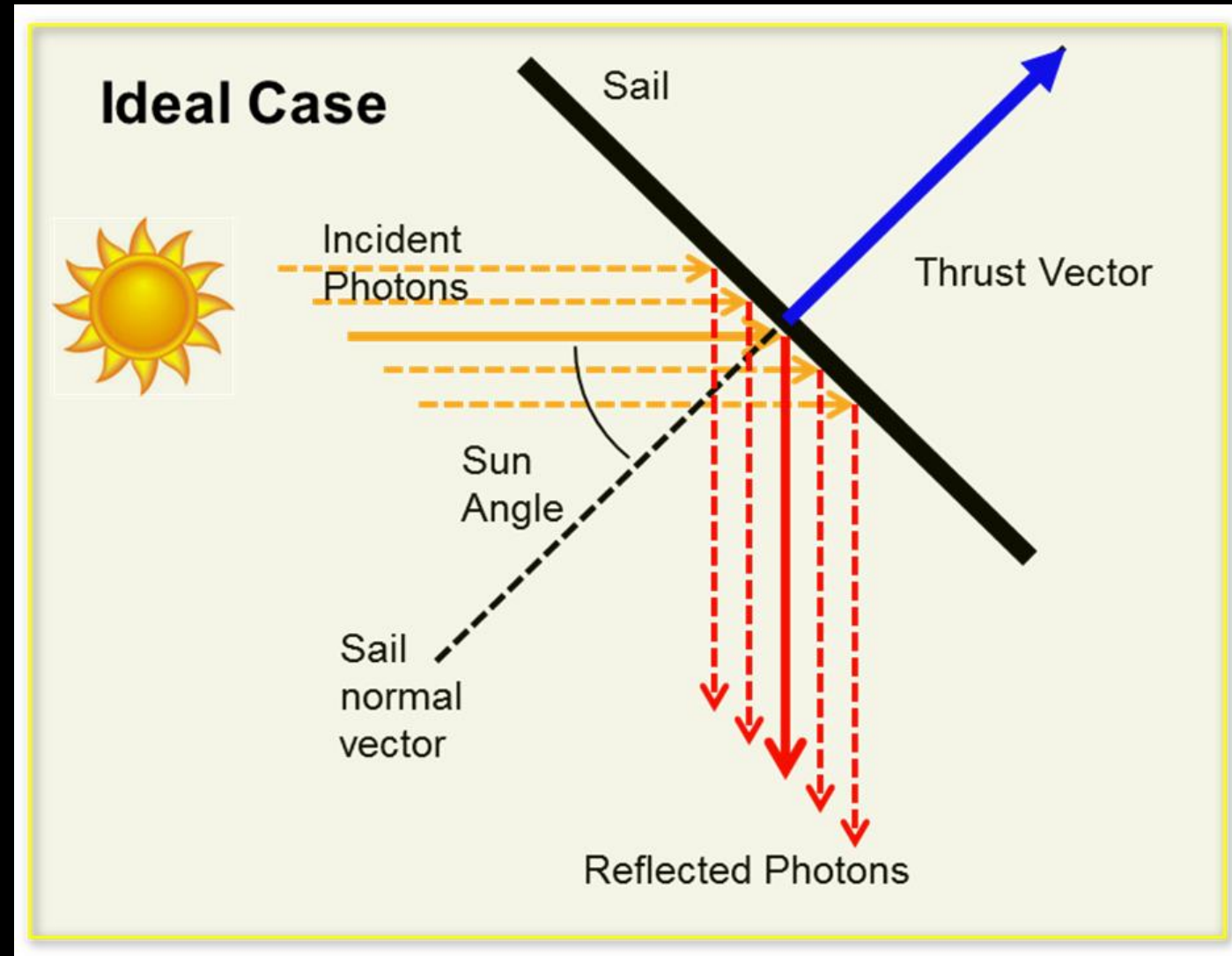

NASA Image

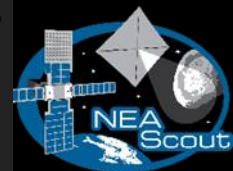

Real Solar Sails Are Not "Ideal"



ISSS 2019

Billowed Quadrant

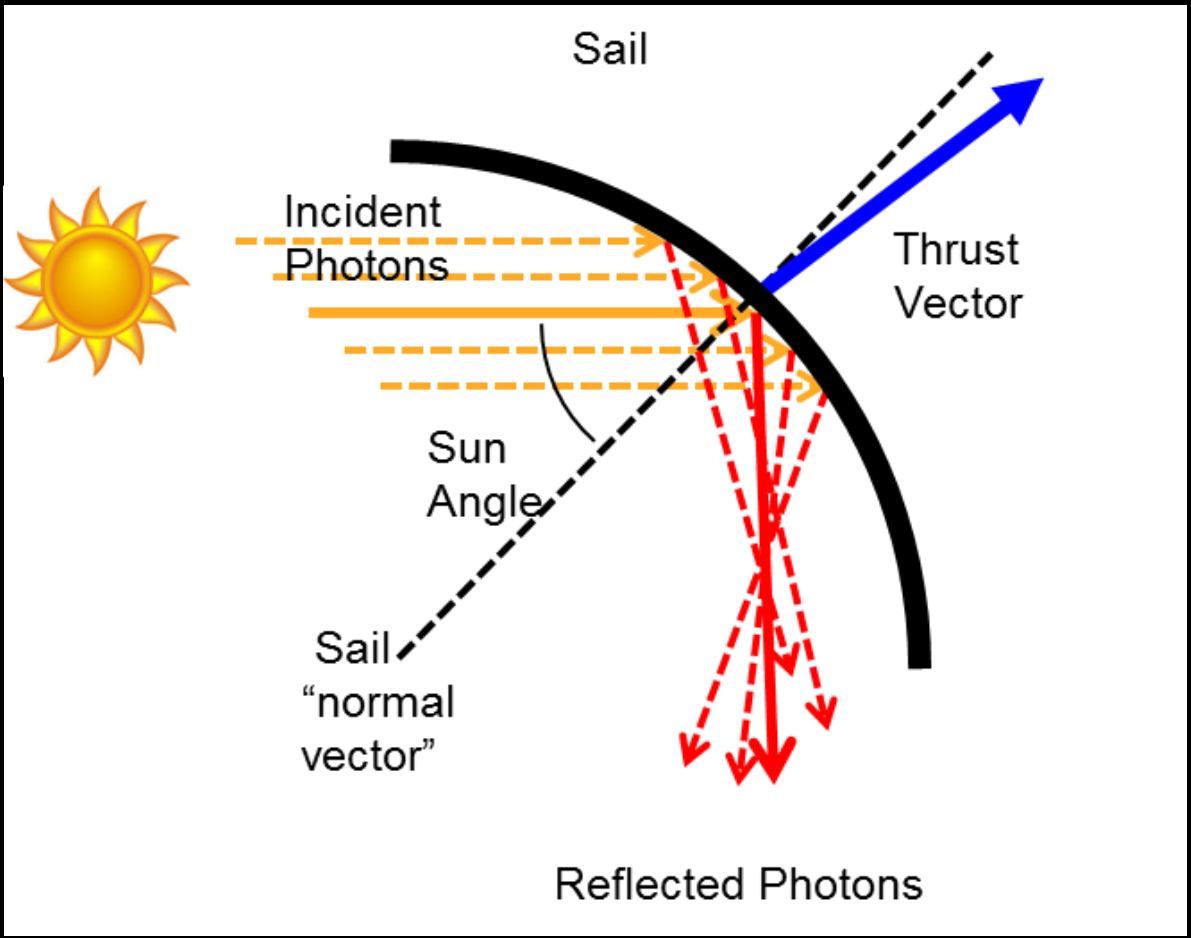

Diffuse Reflection

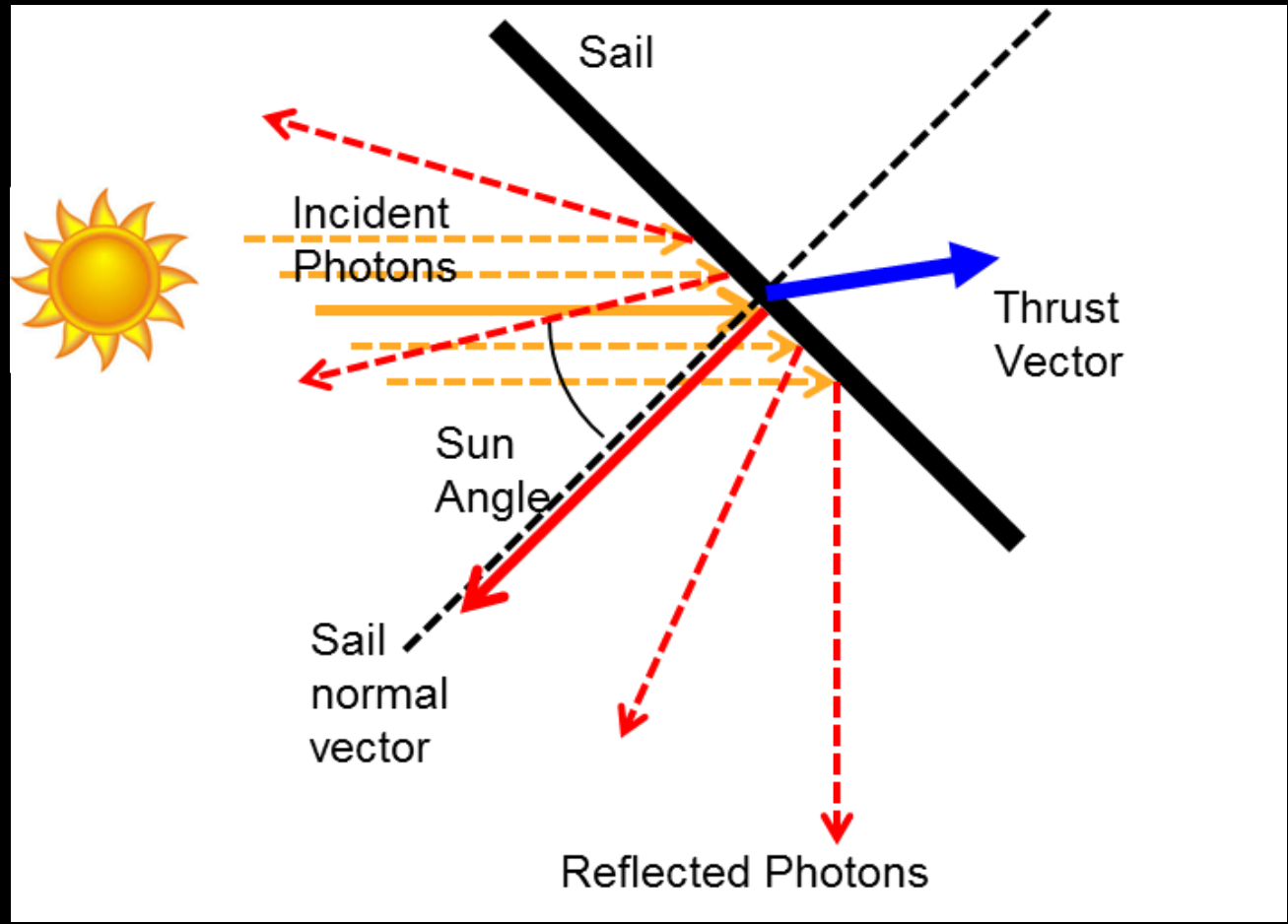



Real Sails Have Imperfections



ISSS 2019

A deployed solar sail has misaligned CM / CP needing correction

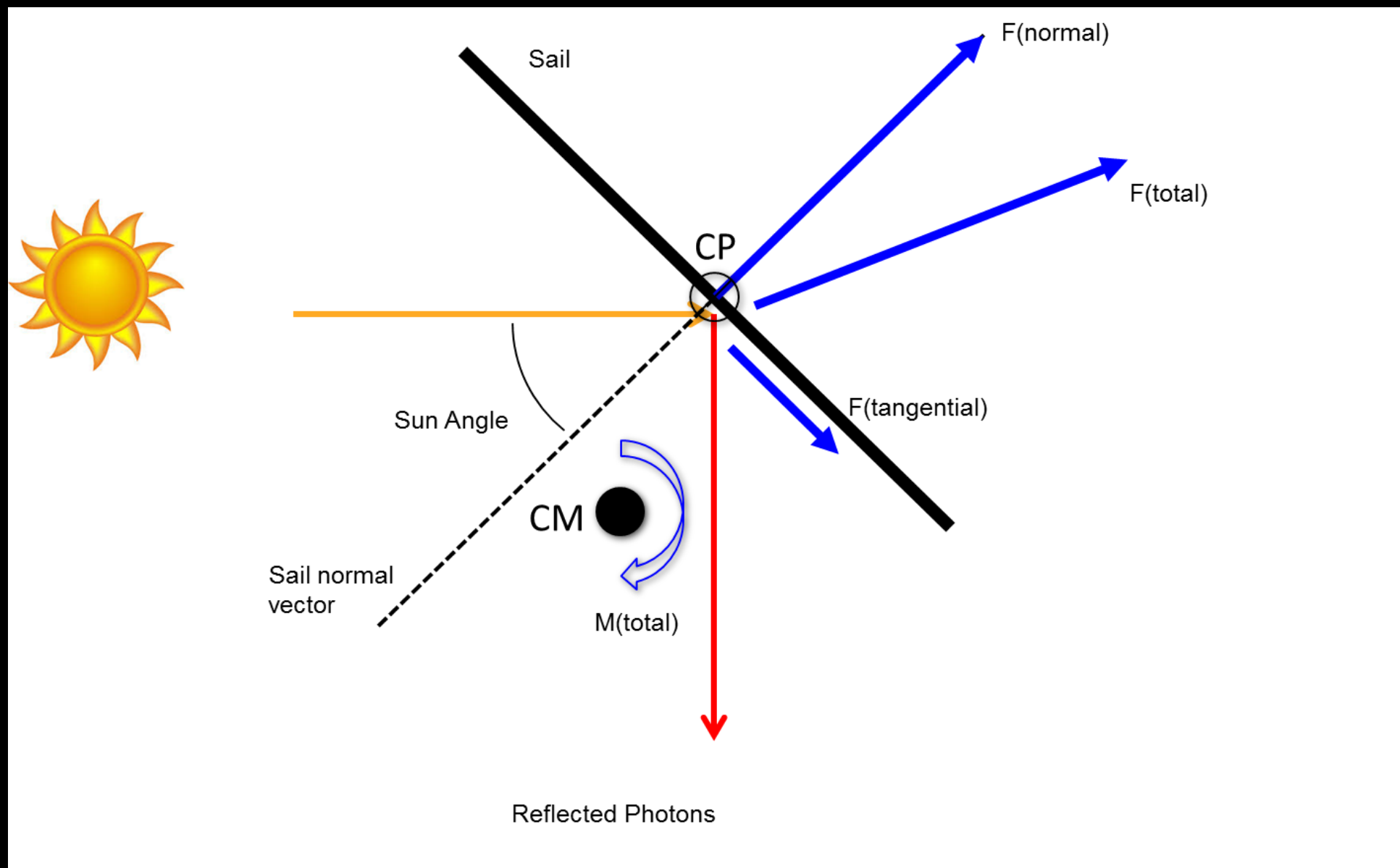

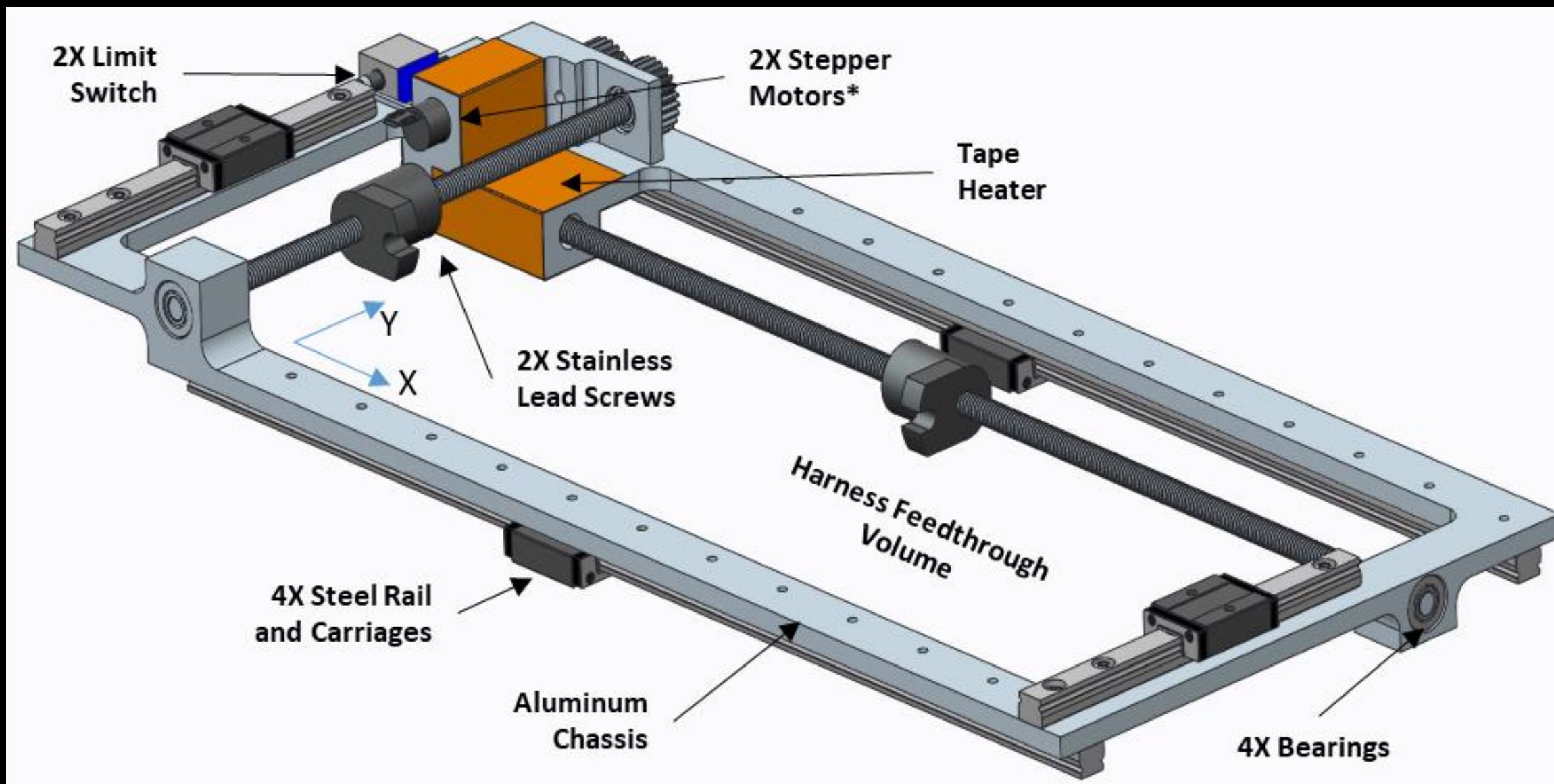

Nominal State

Trimmed State

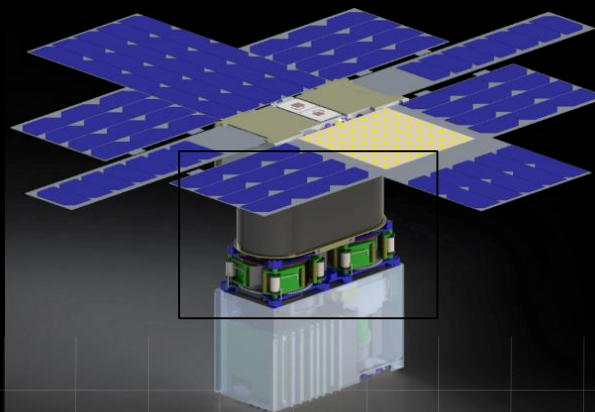
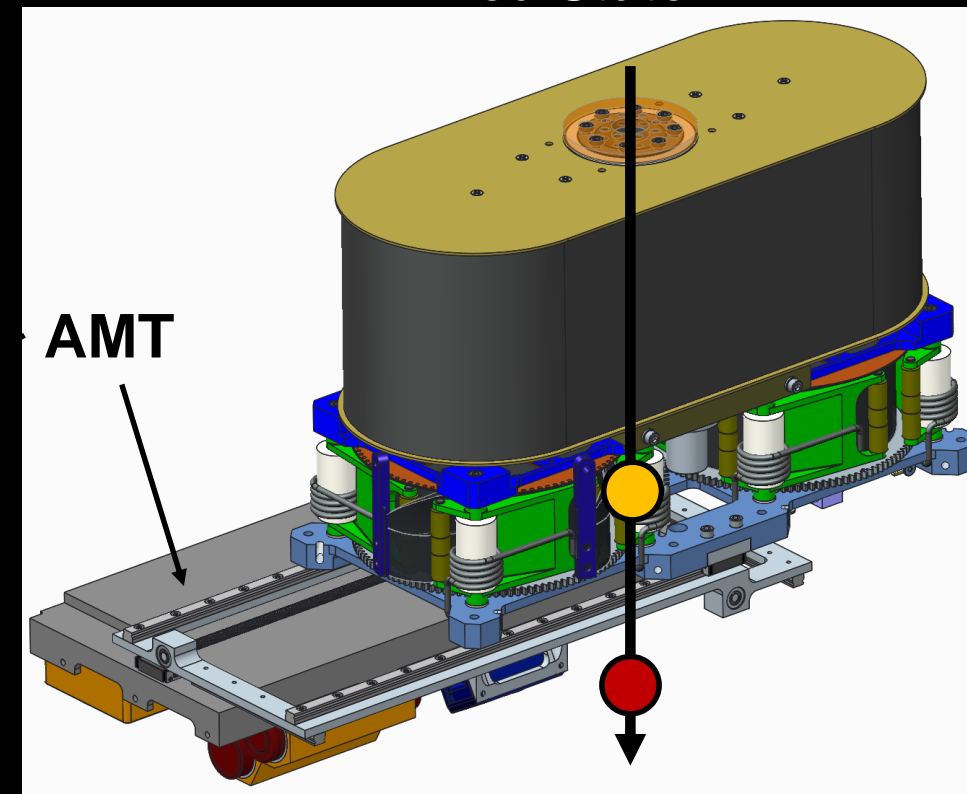
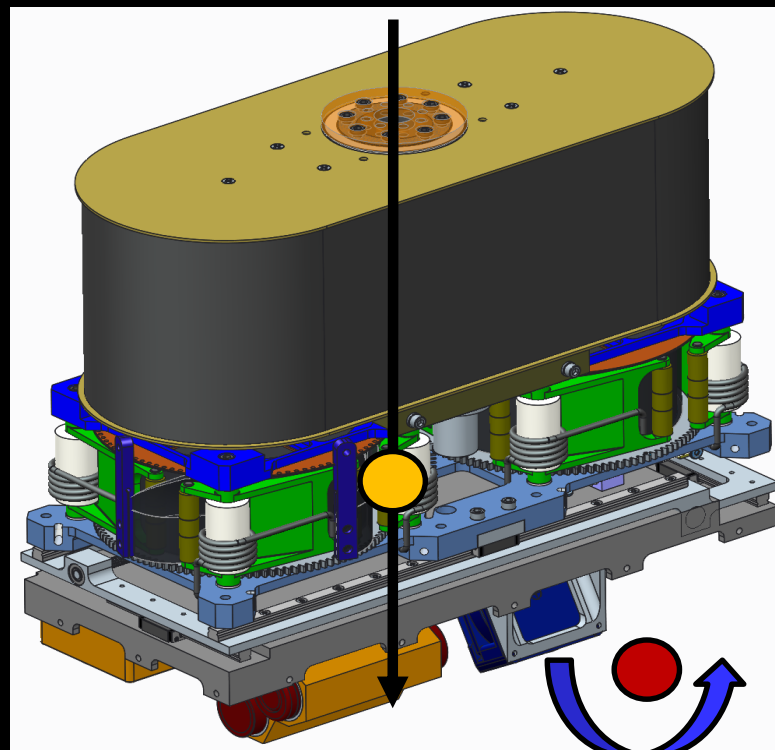
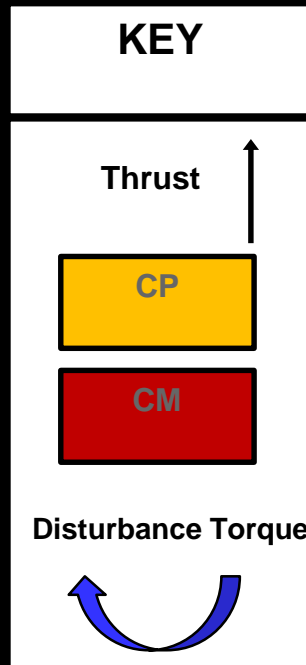

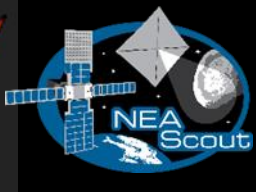

NEA Scout - Status



ISSS 2019



Flight AMT with thermocouples attached for testing



Reaction Control Unit (RCS) Flight Unit

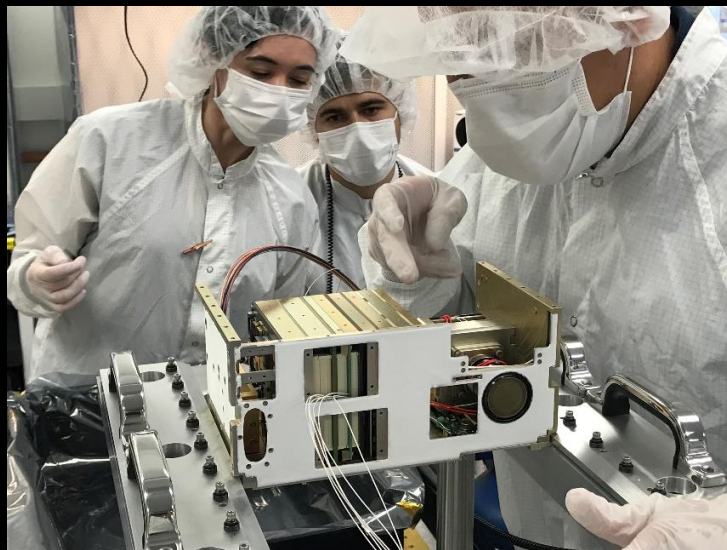

Avionics Box Integration

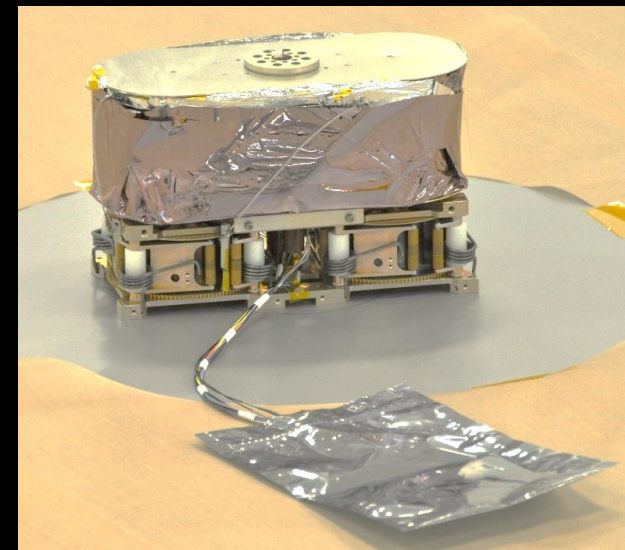

Flight Solar Sail Spooled on Deployer

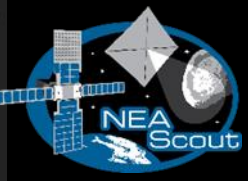

Questions?



ISSS 2019

