

Columbus IFHX Ammonia Leak Analysis

A. Tilloca¹ and S. De Palo²
ThalesAlenia Space, Turin, Italy, 10146

and

E. K. Ungar³
NASA/Johnson Space Center, Houston, TX 77058

After the Columbus Moderate Temperature Loop (MTL) InterFace Heat eXchanger (IFHX) low temperature event of GMT 345-2013, NASA investigated relevant transient scenarios involving IFHX rupture after water freezing and subsequent thawing. NASA recommended development of a Fault Detection Isolation and Recovery (FDIR) plan that would, in the event of a heat exchanger freeze event, close the Water On/Off Valves (WOOVs) to isolate the heat exchanger and prevent ammonia from the external flow loops from spreading into the cabin.

NASA performed a preliminary simplified analysis for the reference case of IFHX rupture, but for a deeper understanding TAS developed detailed SINDA-FLUINT models of the Columbus ITCS that were built and run through the SINAPS GUI. This allowed simulation of the ammonia leakage physics including the variation of environmental parameters, thus providing more accurate and specific input to the FDIR under development. The result was finalization of the IFHX WOOVs closure sequence and wait times to contain the ammonia propagation to Columbus and allow identification of the leaking IFHX. In addition, the analysis results provided reference pressure profiles to be used on console and by the Engineering as support for the telemetry data assessment in case of failure.

This paper gives an overview on the issue and focuses on the analytical aspects of the multiphase fluid dynamics involved.

Nomenclature

<i>BPV</i>	=
<i>BSM</i>	= Berthed Survival Mode
<i>CHX</i>	= Condensing Heat eXchanger
<i>ETCS</i>	= External Thermal Control System
<i>FDIR</i>	= Failure Detection, Isolation and Recovery
<i>GUI</i>	= Graphical User Interface
<i>HX</i>	= Heat Exchanger
<i>IFHX</i>	= InterFace Heat eXchangher
<i>IMV</i>	= Inter-Module Ventilation
<i>ISS</i>	= International Space Station
<i>ITCS</i>	= Internal Thermal Control System
<i>IV</i>	= Isolation Valve
<i>LT</i>	= Low Temperature
<i>MDP</i>	= Maximum Design Pressure
<i>MT</i>	= Moderate Temperature
<i>MTL</i>	= Moderate Temperature Loop
<i>P/L</i>	= PayLoad
<i>PM</i>	= Pump Module

¹ Insert Job Title, Department Name, and Address/Mail Stop for first author.

² Insert Job Title, Department Name, and Address/Mail Stop for second author.

³ Senior Thermal and Fluids Analyst, Crew and Thermal Systems Division, EC2.

- T&HC* = Temperature and Humidity Control
- THMM* =
- WMV* = Water Modulating Valve
- WOOV* = Water On Off Valve
- WPA* =

I. Introduction

Columbus, the European Science Laboratory¹ of the International Space Station (ISS) has an Internal Thermal Control System (ITCS) with a single water circuit able to flow up to 1050 kg/hr, hosting both a Medium Temperature (MT) and Low Temperature (LT) controls. The ITCS cools payloads (P/Ls), subsystem units and the Condensing Heat Exchanger (CHX) (Figure 1).

The ITCS is cooled by two ISS water-ammonia InterFace Heat eXchangers (IFHX), connected to the External Thermal Control System (ETCS)² ammonia cooling loop. Nominal working pressure on the water loop ranges from the lowest pressure at the pump accumulator level, around 1.8 bar, to outlet pump impeller pressure, which depends on the P/Ls water flow requirements and can reach up to 4.5 bar (the loop has a MDP of 8.4 bar). The ETCS ammonia loop operates at a nominal pressure above 20 bar.

Each of the two IFHXs is equipped with a counterflow Heat Exchanger core (HX), an Isolation Valve (IV) and ByPass Valve (BPV), needed to isolate the ammonia loop in case of failure (Figure 2). A bleed line equipped with an orifice links the isolated zone with the outlet line, allowing for a slow pressure equalization that avoids overpressure due to thermal expansion in the isolated zone. The advantage of this solution is that it obviates the use of a fluid expander. The disadvantage is that there is always a hydraulic connection between the heat exchanger core and the ISS ammonia loop, even when it is isolated.

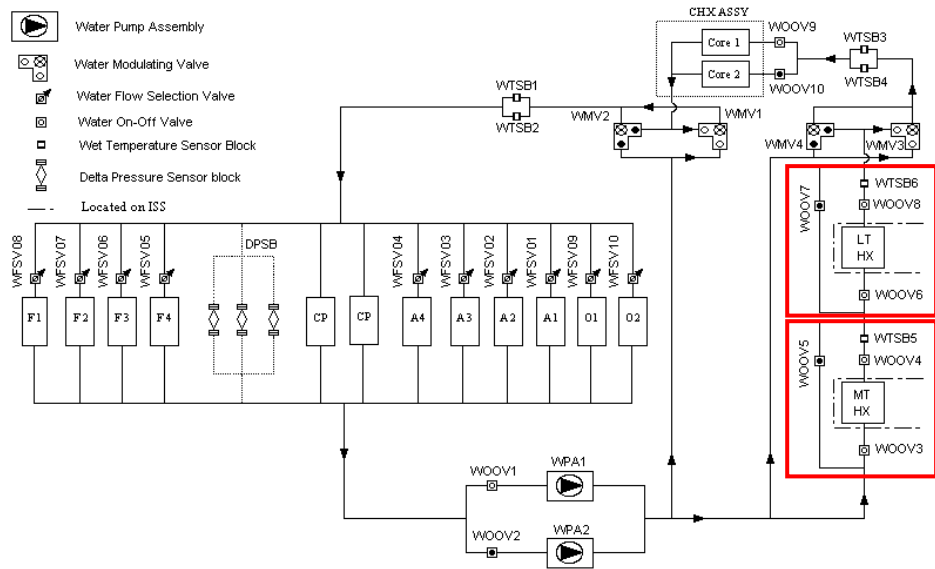

Figure 1. Columbus ITCS Layout

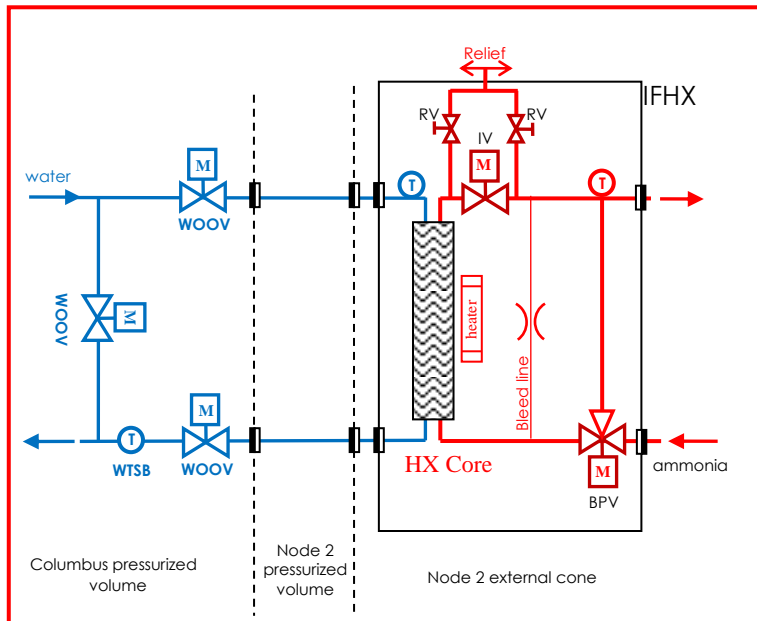

Figure 2. Generic IFHX Thermal Hydraulic Layout Detail

Each IFHX is further equipped with two temperature sensors and two pressure relief valves placed across the isolation valve. Heaters are installed inside the IFHX around the internal water lines and on the HX core, avoiding water freezing in case of water stagnant condition.

In case of breach through the HX core, pressurized ammonia would enter into the ITCS with possible cabin intrusion, prompting the crew to wear emergency masks, evacuating the module, and possibly leading to the loss of the module. A rupture was not considered a credible failure during the design phase, so a scenario considering ammonia intrusion into the ITCS was never modeled nor were its impacts evaluated.

On December 11th, 2013, an event occurred on board the ISS as described in the relevant NASA Mishap Report³:

the Pump Module (PM) Flow Control Valve of ETCS Loop A, linked to MTHX IFHX, failed dropping down the ammonia temperature to a point where the water could freeze. The water flow through the HX was stopped and the ammonia flow was bypassed. However, the HX core heater was not activated – allowing the core temperature to approach freezing. From this point on, rupture at different levels of leakage became credible and – after the mishap - activities were performed to understand how to mitigate the event and its impacts, mainly in terms of FDIR reactions.

From the analytical standpoint, major attention was devoted to evaluation of intermediate conditions, where small amounts of ammonia are slowly released to the water coolant circuit through small leaks and subsequently released to cabin air^{4,5,6}.

Models and analyses of the ITCS loop in case of freezing and thawing are presented in the present work. A first 0-D model was built by NASA to evaluate reactions on the accumulator side of the ITCS and then a more detailed model, based on the CDR Thermal Hydraulic Mathematical Model (THMM), was set up to confirm the first simulations through a separate modelling approach and provide other details such as the ammonia wave front location vs WOOVs position.

II. Ammonia Leak 0-D Model

A first order model was built in Excel to track the response of the Columbus ITCS after the thaw of an isolated failed heat exchanger. The conditions before the start of the analysis were:

- The heat exchanger water side is frozen,
- One side of the heat exchanger water flow path is isolated (one WOOV is closed) stopping water flow in the plumbing between the IFHX and the pump package,
- The EITCS is at 2070 kPa,
- The ITCS is at 160kPa,
- The accumulator water charge is 4 liters (with 16 liters of nitrogen gas).
- There is 36.7 liters of stagnant volume in the water lines between the IFHX and the pump package.

In the initial state, the frozen water prevents communication between the loops and the flow of ammonia into the ITCS. At time zero in the model, the ice has melted sufficiently to allow the flow of ammonia through the heat exchanger breach. The breach is assumed to be larger than the 0.76 mm bleedline orifice in the otherwise isolated ammonia ETCS lines so the bleedline orifice limits the ammonia flow. The ammonia is liquid at 0°C and 2070 kPa upstream of the bleedline orifice and initially flows into the ITCS at a rate of 1.25 l/min of liquid. The ammonia flowing across the orifice will partially vaporize. Because the 15 kW it would take to completely vaporize the liquid is not available, the process is constant enthalpy. Based on adiabatic expansion to the ITCS pressure, the initial quality is 0.083 and the initial homogeneous void fraction is 0.987.

As ammonia enters the system the accumulator strokes, which increases the system pressure. This decreases the ammonia flow rate and compresses any ammonia vapor that has already entered the ITCS. The vapor does not condense because the available heat leak is small.

The accumulator continues to fill until it is fully stroked. The fully stroked accumulator contains 12.65 liters of water and 7.35 liters of nitrogen gas. During the accumulator fill and associated pressure rise, there are three trigger points:

1. ISS Emergency Automatic Action at 250 kPa– inter-module ventilation (IMV) is stopped.
2. Warning Automatic Reaction at 267 kPa – COL water pump shutoff signal, all fans shut off.
3. At 300 kPa the accumulator nitrogen mechanical relief valve opens. The relief valve has a 0.326 mm orifice.

Only the accumulator relief valve opening affects the analysis. IMV is immaterial to the ITCS operation. The WPA shutoff does not affect the analysis since the line being filled with ammonia is already stagnant.

The Excel model incorporated the following key thermodynamic assumptions:

- The two-phase ammonia in the ITCS is considered to be locally homogeneous for the purposes of mass tracking.
- Nitrogen gas and ammonia vapor compression are considered to be adiabatic and reversible, i. e., isentropic, owing to the limited heat transfer from the lines.
- There is no mixing in the lines. The incremental ammonia inflow was taken as slugs that were tracked separately.
- The minimal amount of the ammonia vapor that would be absorbed by the stagnant water front is neglected.

The Excel model allowed the system performance to be tracked by calculating the ammonia inflow, the accumulator performance, and the system pressure. The ITCS pressure following the IFHX breach is shown in Figure 3. The breach occurs at 0 seconds and the ITCS pressure increases as ammonia enters the lines and forces liquid into the accumulator. At 18.5 seconds, the nitrogen relief pressure is reached and N₂ is vented from the gas side of the accumulator. As time

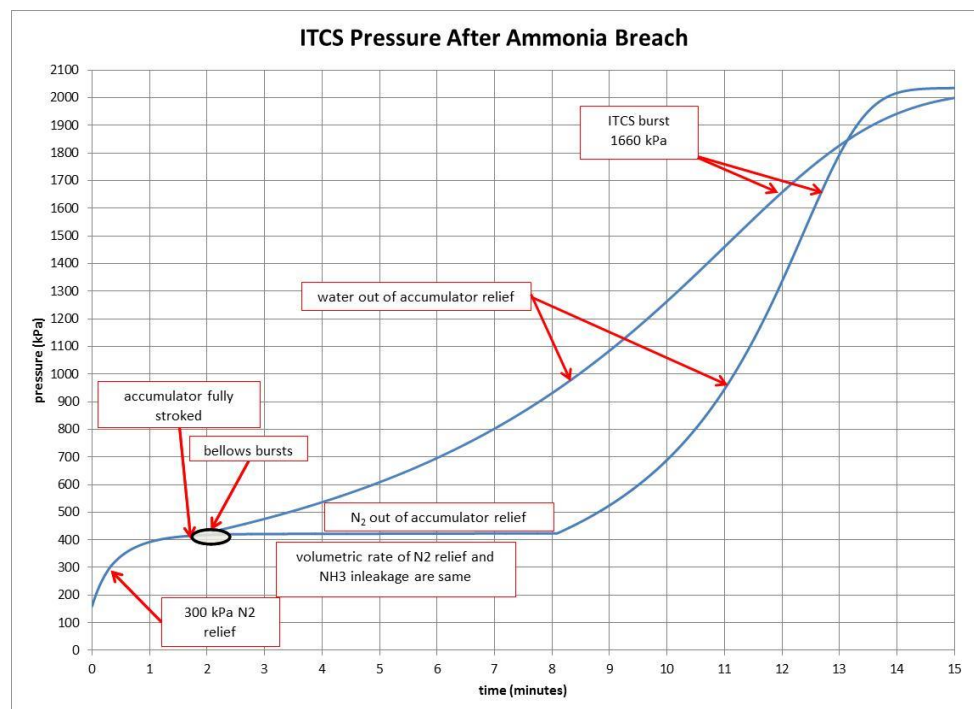

Figure 3. ITCS Pressure Immediately Following an Ammonia Breach

passes, the ITCS pressure continues to build.

The accumulator nitrogen continues to vent until the accumulator is fully stroked at 1.77 minutes. The bellows is assumed to fail immediately allowing the ITCS water and nitrogen pressurant to mix. This yields two limit cases that envelope the subsequent venting behavior - all nitrogen or all water venting through the relief valve.

For the all nitrogen limit case, the ITCS pressure remains constant once a volumetric balance is reached between the ammonia entering the loop and the venting nitrogen. At 8.1 minutes all the nitrogen has been vented from accumulator and water begins to flow through the relief valve. Since the relief valve area is 20% of bleedline orifice area, the relief valve vent becomes the limiting factor. Existing ammonia vapor in the ITCS is compressed by the incoming liquid until the 1660 kPa burst pressure is reached at 12.6 minutes.

For the all water venting case, the relief valve governs the system pressure. The accumulator nitrogen and existing ammonia vapor is compressed by incoming liquid until the 1660 kPa burst pressure is reached

The ITCS bursts between 12.0 and 12.6 minutes. Because the lines have a very high burst pressure, the failure would be expected to occur in the pump package. In both limit cases, the ammonia volume in the ITCS at burst is less than the 36.7 liters of loop volume between the IFHX and the pump package.

At burst, the ITCS pressure instantaneously drops from 1660 to ~101 kPa expanding the compressed ammonia vapor and allowing a flow of 1.27 l/min of liquid ammonia through the bleedline orifice. A constant enthalpy expansion to 101 kPa results in 105 l/min of ammonia vapor (plus liquid) – enough to reach the COL pump package in a fraction of a minute. ITCS fluid, ammonia vapor, and liquid ammonia would be ejected into cabin.

III. Ammonia Leak 1-D Model

A detailed ITCS loop THMM was built in the past with the Esatan-FHTS tool, to support the Columbus CDR phase. The model is currently maintained for on-orbit Stage Analysis and troubleshooting activities^{7,8}. On the FHTS model, the IFHXs are represented as temperature boundaries and the water volume belonging to the external plumbing is not explicitly modeled. An equivalent volume/pressure drop is taken into account as per relevant ICD. Further, the WPA accumulator is represented only as boundary pressure – its volume is not modeled directly since its stagnant water does not affect nominal thermal hydraulic simulations.

A new model based on the FHTS model was developed through the SINAPS GUI in SINDA-FLUENT⁹, as this tool was judged by the authors to be a better choice for severe transients because it contains tanks and two-phase/two fluid modelling. The original FHTS layout was upgraded for the ammonia leak simulations as follows:

- Implementation of external lines linking the ITCS loop to MT-HX and to LT-HX.
- Including the WOOV's hydraulic characteristic and closure profile
- The accumulator is simulated using one node for the water volume and one node for the N₂ volume separated through an adiabatic interface.
- Including the relief valve on the nitrogen side of the accumulator.
- Modeling the IFHX bleed line using a calibrated orifice with an inner diameter of 0.76 mm.

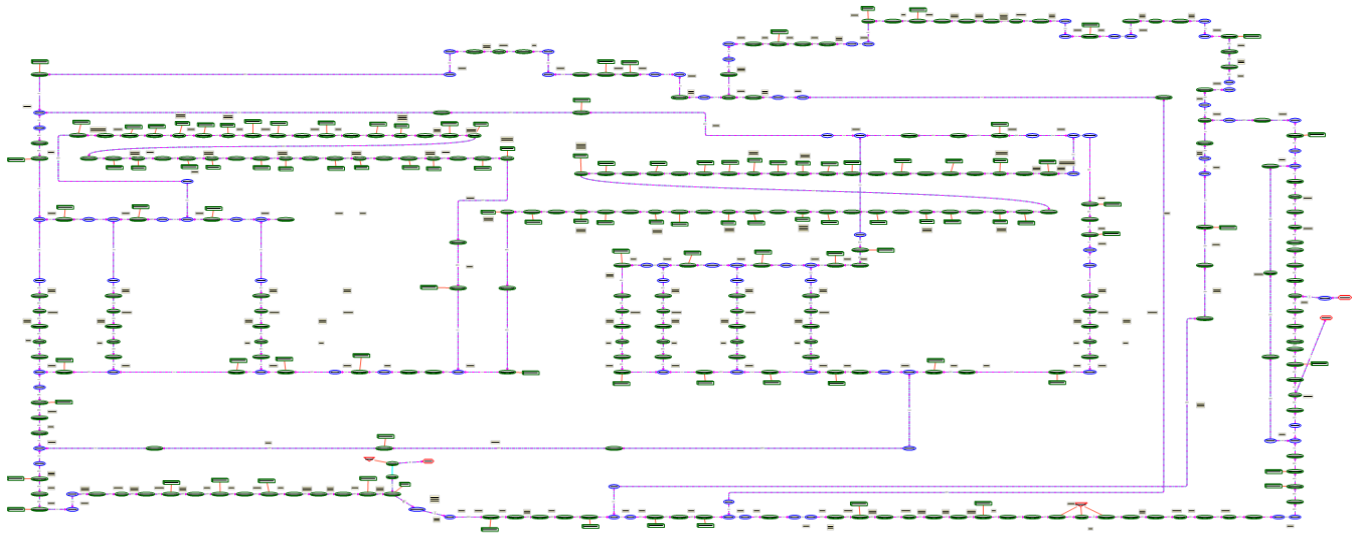

Figure 4. SINAPS GUI Screenshot of the ITCS Model

The 1-D SINDA-FLUINT model is not only able to simulate the physics of the ammonia leakage, but thanks also to layout discretization, provides more accurate and specific input to the FDIR that in the previous version. The following were used as inputs in the model:

1. Bypass and isolate the ammonia valves on MTL IFHX when the WPA accumulator pressure reaches 210 kPa by opening WOOV5 and closing WOOV3 and WOOV4 (see Figure 1).
2. Bypass and isolate the ammonia valves on LTL IFHX when the accumulator pressure reaches 250 kPa by opening WOOV7 and closing WOOV6 and WOOV8 (see Figure 1).

Analyses were then performed to finalize the FDIR in terms of IFHX WOOV's closure sequence, pressure profiles and wait times to contain the ammonia propagation to ITCS and properly identify the leaking IFHX. In addition, the analysis results provided reference pressure profiles to be used on console and by Engineering as support for the telemetry data processing in case of failure. Work performed investigated also pressure thresholds for the IFHX WOOV closure, with the goal of avoiding accumulator rupture while trying to identify the leaking heat exchanger.

The following three case sets were investigated with the 1-D model based on the Reference Case of IFHX rupture. There was no water flow through the IFHX branch, similar to the 0-D analysis:

- Case 1: preliminary version of the FDIR (as described before) and maximum initial accumulator pressure (1.8 bar).
- Case 2: preliminary version of the FDIR (as described before) and minimum initial accumulator pressure (1.65 bar).
- Case 3: enhanced version of the FDIR and updated minimum accumulator pressure (1.7 bar)

For each analysis case both MTL IFHX and LTL IFHX failure were simulated. The conditions before the start of the analysis were:

- Frozen heat exchanger,
- Accumulator water charge of 5 liters (maximum operational value, with 14.63 liters of nitrogen gas).
- Minimum ITCS water mass flow rate, i.e., 300 kg/hr.

The following values were used for the temperature control setpoints:

- Inlet CHX set to 7 °C. This value is worst w.r.t the other value of 5°C, sometimes set to increase condensate removal, since the higher is the loop temperature the higher is the ammonia expansion in the loop.
- Nominal inlet plenum temperature of 17 °C

A. Case 1

Figure 5 shows the accumulator pressure trends obtained for Case 1, both for LT and MT HXs failures. IFHX failure is set up at time 5 s, where the ammonia starts to flow into the ITCS.

For MTL IFHX failure simulation WOOV4 is closed while WOOV3 is left open and water flow through its bypass branch obtained via WOOV5 opening: the MTHX is thermally isolated from the ITCS while keeping the hydraulic connection to the system accumulator. Due to ammonia injection into ITCS the accumulator pressure builds up and, 4 s after it reached 2.1 bar, WOOV3 starts its closure (see trigger/exec boxes on Figure 5) initiating the full isolation of the MTHX branch from the system. Let's recall that WOOVs full movement requires 10 s to complete from end to end.

While WOOV3 is closing, the accumulator pressure reaches 2.5 bar (3 s later) and WOOV7 starts to open and 4 s after the accumulator pressure reaches 2.5 bar, WOOV8 and WOOV6 start to close.

The maximum accumulator pressure reached is 2.65 bar, very close to 2.67 bar, the pressure that triggers system transition to Berthed Survival Mode (BSM), with an accumulator volume of 9.75 liters. Let's note that with respect the 0-D model, the SINDA-FLUINT model allows monitoring of the ammonia front propagation, with the hypothesis of homogeneous flow, and results show that 4.5 g of vapor ammonia are able to flow through WOOV3 before its full closure. This amount of ammonia continues to expand thanks to ITCS lower pressure and is responsible for the accumulator volume and pressure increase even after that failed MTL IFHX branch is isolated from the ITCS.

A similar run was performed for the LTL IFHX failure simulation, where thermal insulation of the HX is obtained with WOOV8 closed and WOOV6 and WOOV7 (bypass) open; 3s after the accumulator pressure reaches 2.1 bar the MTHX bypass and isolation is started. Four seconds later, after the accumulator pressure reaches 2.5 bar, LTHX isolation starts. In this case, during LTHX isolation, the accumulator pressure exceeds 2.67 bar and ITCS water pump is stopped according to BSM transition. The maximum accumulator pressure reached is of 3.8 bar corresponding to a maximum accumulator volume at end of stroke - close to 13 liters.

In this case the amount of ammonia trapped into ITCS is more than doubled, around 11.6 g with a large liquid fraction (8 g). For this reason, the pressure increase after failed HX isolation is consistently higher.

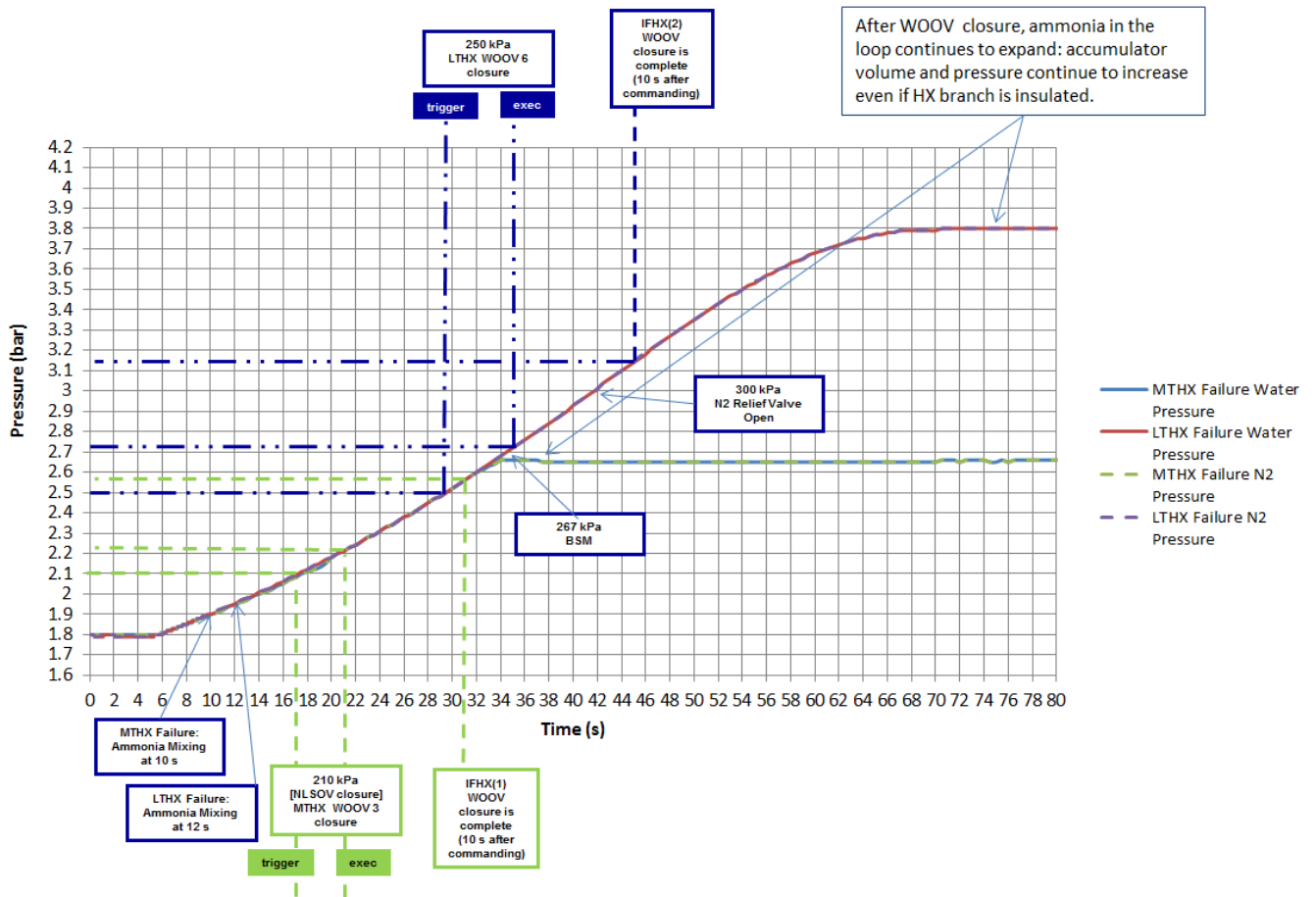

Figure 5. Accumulator Pressure Response for Case 1

The analysis results show that pressure trends in case of MTL IFHX failure or LTL IFHX failure are quite different: since LTHX WOOV starts to close later more ammonia can enter the loop leading to a higher final pressure in the accumulator. The selected wait times and triggering thresholds between MTL IFHX and LTL IFHX WOOV closure allow identification of the failed HX. However, in case of LTHX failure, the accumulator reaches the end of stroke with a possible risk of bellows rupture.

The pressure increase obtained with the 1-D SINDA-FLUINT model is slower than the one predicted with 0-D model: the detailed geometrical discretization of the SINDA-FLUINT model allows the inclusion of the pressure drop effect along the ITCS loop due to the (high) ammonia volumetric flow rate. Once the ammonia starts to flow in the ITCS loop the pressure at IFHX is higher than the accumulator one, thus limiting the ammonia expansion.

B. Case 2

In Figure 6 is reported the accumulator pressure trend for Case 2. This case is similar to the previous one, with the exception of a lower initial accumulator pressure (1.65 bar).

Analysis results show that a lower initial accumulator pressure is more critical from the maximum accumulator pressure standpoint since:

- a lower initial pressure on the loop lead to have an higher ammonia vapor volumetric flow rate
- starting from a lower pressure in the accumulator, the ammonia has more time to enter the loop before WOOVs activation threshold are reached.

Pressure trends in case of MTHX failure or LTHX failure are quite different: since LTHX WOOV's start to close later (2.5 bar) a higher ammonia volume can enter the loop leading to have a higher final pressure in the accumulator. The selected wait times and triggering thresholds between MTHX and LTHX WOOV's closure allow understanding which is the failed HX. However, in case of LTHX failure, the accumulator reaches the end of stroke with a possible risk of bellows rupture.

The water pressure step in the LTHX failure curve is due to the accumulator reaching the end of its stroke: once the bellow has reached full extended position, the accumulator cannot expand anymore and the pressure on the water side sharply increases. Note that only the nitrogen accumulator pressure telemetry is available and the model does not simulate the accumulator rupture, therefore it is expected that the reading of the gas pressure remains flat until accumulator rupture (shown in the picture as a dashed line), then a sudden change will occur (it is expected for the pressure reading to be intermediate between the water and gas side pressures).

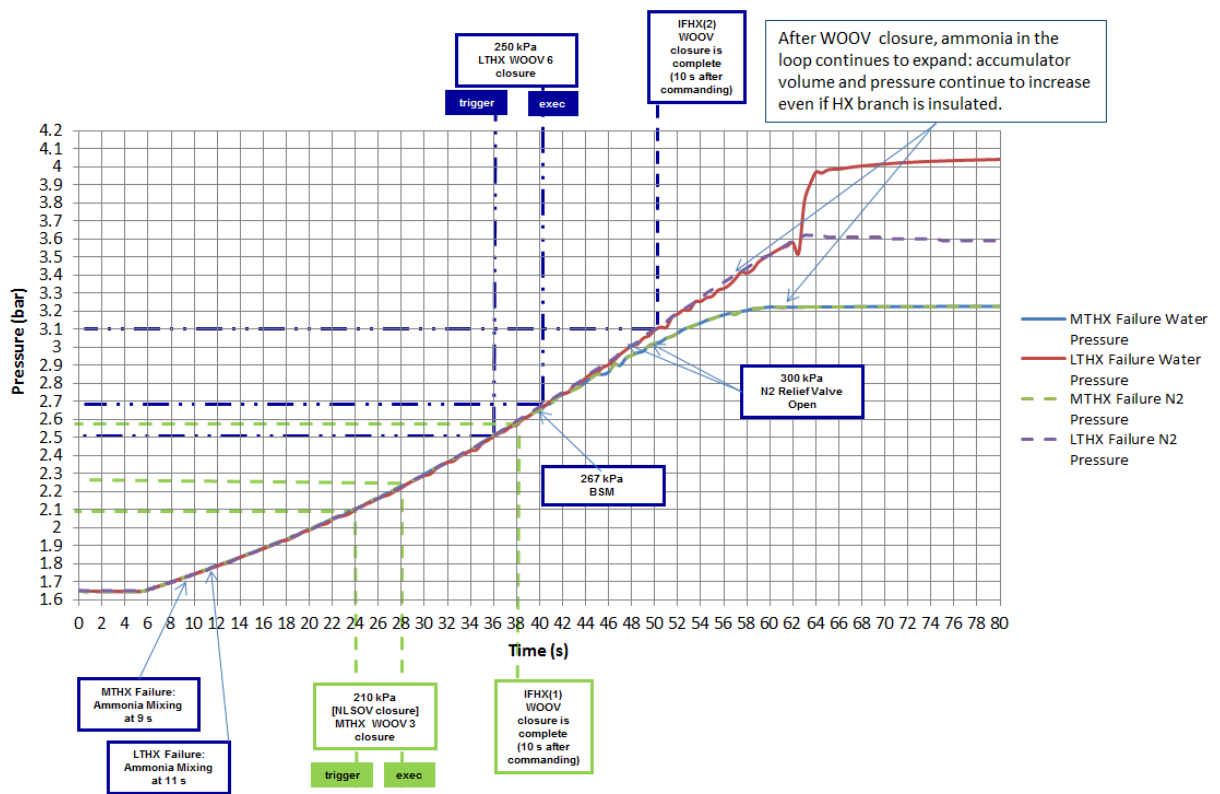

Figure 6. Accumulator Pressure Response for Case 2

C. Case 3

Case 3 was performed in order to improve the FDIR algorithm: an additional effort was dedicated to verify if the conditions exist to avoid accumulator rupture and still allow identification of the leaking IFHX. Based on previous results the following trigger thresholds were selected:

- MTL IFHX pressure trigger @ 1.95 bar instead of 2.1 bar
- LTL IFHX pressure trigger @ 2.20 bar instead of 2.5 bar

The accumulator pressure trends for Case 3 are shown in Figure 7. The selected initial accumulator pressure and triggering thresholds allow the failed HX to be identified while avoiding the end of stroke conditions seen in the most severe LTHX failure.

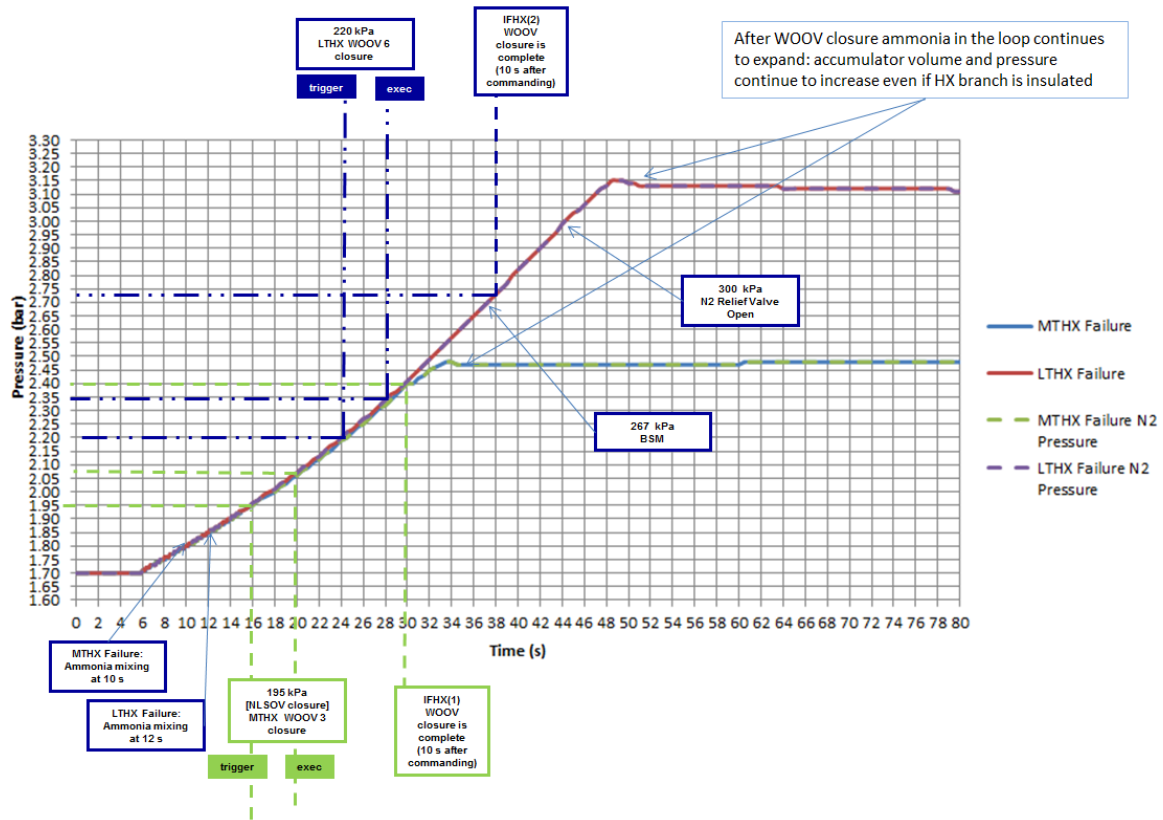

Figure 7. Accumulator Pressure Response for Case 3

IV. Conclusion

An outcome of the Columbus MTL IFHX Close-Call Investigation concerning possible water icing of the IFHX occurred on-orbit on GMT 345-2013, led to an investigation of the transient ruptured heat exchanger scenario. It was recommended to “Pursue capability to develop a FDIR that would close the WOOVs to prevent the spread of ammonia into the Columbus cabin”.

A first 0-D model was set up by NASA to evaluate reactions on the accumulator side of the ITCS. The analysis shows that the ITCS reaches bursts pressure between 12.0 and 12.6 minutes after ammonia leak event, which could result in a catastrophic loop failure and ammonia liquid and vapor being ejected into the cabin.

A more detailed model, based on the CDR ITCS Thermal Hydraulic Mathematical Model (THMM), was set up to confirm the first simulations through a separate modelling approach. It was built with the SINDA-FLUINT thermal/fluid analyzer. The detailed model was able to provide more accurate results and specific input to the FDIR.

Analyses with the detailed model allowed finalizing the FDIR in terms of the IFHX WOOVs closure sequence, closure thresholds, pressure profiles and waiting times to limit the ammonia propagation in the ITCS to avoid cabin contamination and accumulator rupture. It also allowed identification of leaking IFHX through telemetry. In

addition, the analyses results provided reference pressure profiles to be used on console and by Engineering as support for the telemetry data assessment in case of failure.

Acknowledgments

The authors would like to thank the NASA and ESA technical team for their participation to the COL IFHX rupture investigation and to the FDIR definition.

References

¹De Palo, S., Bufano, G., Szigetvari, Z., and Persson, J., “Six Years of Columbus TCS Flight Activity”, *Proceedings of 44th International Conference on Environmental Systems*, ICES-2014-280, 13-17 July 2014, Tucson, Arizona, USA.

²Paper on ISS external loop (TBD)

³Derkowski, B., “Columbus (COL) Moderate Temperature (MT) Interface Heat Exchanger (IFHX) Freeze Close Call”, NASA Mishap Report OB-2013-01

⁴Numerical Study of Ammonia Leak Propagation Characteristics in Node 2

⁵Parodi, P., Locantore, I., De Palo, S., Szigetvari, S., and Hinderer, S., “Analysis of Ammonia Moderate Leakage in Columbus,” *Proceedings of the 45th International Conference on Environmental Systems*, ICES-2015-225, 12-16 July 2015, Bellevue, Washington, USA

⁶Chang, H. Son, Ivanov, N.G., Telnov, D.S. and Smirnov, E.M., “Numerical Study of Ammonia Leak and Dispersion in the International Space Station”, *Proceedings of the 42nd International Conference on Environmental Systems (ICES)*, July 15-19, 2012

⁷ICES 2010 paper ”TMM management for mission support and TCS on-orbit verification”

⁸ De Palo, S., Burzagli, F., Gilardi, C. and Truscelli, G., “Columbus Water Transfer On-Orbit Activity”, *Proceedings of the 43rd International Conference on Environmental Systems (ICES)*, July 14-18, 2013.

⁹www.crtech.com