

Optical Instrument Thermal Control on the Large Ultraviolet/Optical/Infrared Surveyor

Kan Yang^a, Matthew R. Bolcar^a, Julie A. Croke^a, Jason E. Hylan^a, Sang C. Park^b
Regis Venti^a, Bryan D. Matonak^a, Michael K. Choi^a

^aNASA Goddard Space Flight Center, 8800 Greenbelt Rd., Greenbelt, MD 20771;

^bHarvard Smithsonian Center for Astrophysics, 60 Garden St., Cambridge, MA 02138

ABSTRACT

The Large Ultraviolet/Optical/Infrared Surveyor (LUVOIR) is a multi-wavelength observatory commissioned by NASA as one of four large mission concept studies for the Astro2020 Decadal Survey. Two concepts are under study which bound a range of cost, risk, and scientific return: an 8-meter diameter unobscured segmented aperture primary mirror and a 15-meter segmented aperture primary mirror. Each concept carries with it an accompanying suite of instruments. The Extreme Coronagraph for Living Planetary Systems (ECLIPS) is a near-ultraviolet (NUV) / optical / near-infrared (NIR) coronagraph; the LUVOIR Ultraviolet Multi-object Spectrograph (LUMOS) provides multi-object imaging spectroscopy in the 100-400 nanometer ultraviolet (UV) range; and the High Definition Imager (HDI) is a wide field-of-view near-UV / optical / near-IR camera that can also perform astrometry. The 15-meter concept also contains an additional instrument, Pollux, which is a high-resolution UV spectro-polarimeter. While the observatory is nominally at a 270 Kelvin operational temperature, the requirements of imaging in both IR and UV require separate detectors operating at different temperature regimes, each with stringent thermal stability requirements. The change in observatory size requires two distinct thermal designs per instrument. In this current work, the thermal architecture is presented for each instrument suite. We describe here the efforts made to achieve the target operational temperatures and stabilities with passive thermal control methods. Additional discussion will focus on how these instrument thermal designs impact the overall system-level architecture of the observatory and indicate the thermal challenges for hardware implementation.

Keywords: LUVOIR, Decadal Survey, Astronomy, Astrophysics, Thermal Engineering, Thermal Design, ultraviolet, infrared

1. INTRODUCTION

The Large Ultraviolet/Optical/Infrared Surveyor (LUVOIR) is one of four large strategic mission concept studies for the 2020 Decadal Survey in Astronomy and Astrophysics. The science enabled by LUVOIR's size covers a broad range of astrophysics, from characterization of the reionization epoch after the Big Bang to studies of galaxy and planet evolution and star and planet formation. LUVOIR also seeks to directly image a wide range of exoplanets, including Earth-sized rocky worlds, to understand their atmospheric and surface composition. By looking for biosignatures and assessing their habitability, it seeks to answer the question "are we alone in the universe?" If life is found elsewhere, then "how common is it?"

Two concepts were considered for study by the LUVOIR Engineering Team that bound the range of cost, risk, and scientific return. LUVOIR-A is a 15 meter diameter segmented aperture primary mirror with an on-axis design, while LUVOIR-B is an 8 meter diameter unobscured segmented aperture primary mirror with an off-axis design. Both concepts were designed to the same rigorous requirements to enable LUVOIR's science goals: a large, segmented aperture, a broad spectrum of wavelength sensitivities from near-infrared (NIR) to ultraviolet (UV), and picometer-level wavefront stability via precise thermal and mechanical control^{1,2}.

*kan.yang@nasa.gov; phone 1 301 286-9468; nasa.gov

LUVOIR has a temperature requirement for its telescope optical components and structure to achieve 270 K. This temperature was chosen for three reasons: (1) the favorable material properties for both M55J composite structure and Ultra Low Expansion (ULE) glass at this temperature, with a near-zero coefficient of thermal expansion benefiting the thermal stability; (2) the ability to perform science in NIR, in which colder temperatures are desirable; and (3) to minimize the impact of contaminants condensing and sticking on optical surfaces critical to LUVOIR far-UV science. For high-contrast exoplanet imaging, a thermal stability requirement of ± 0.001 K is necessary to achieve the ultra-stable wavefronts to enable this science goal. A more comprehensive look at the trade studies which gave rise to these two designs can be found in the LUVOIR Final Report³ and Yang et al⁴.

1.1 LUVOIR System-Level Thermal Design

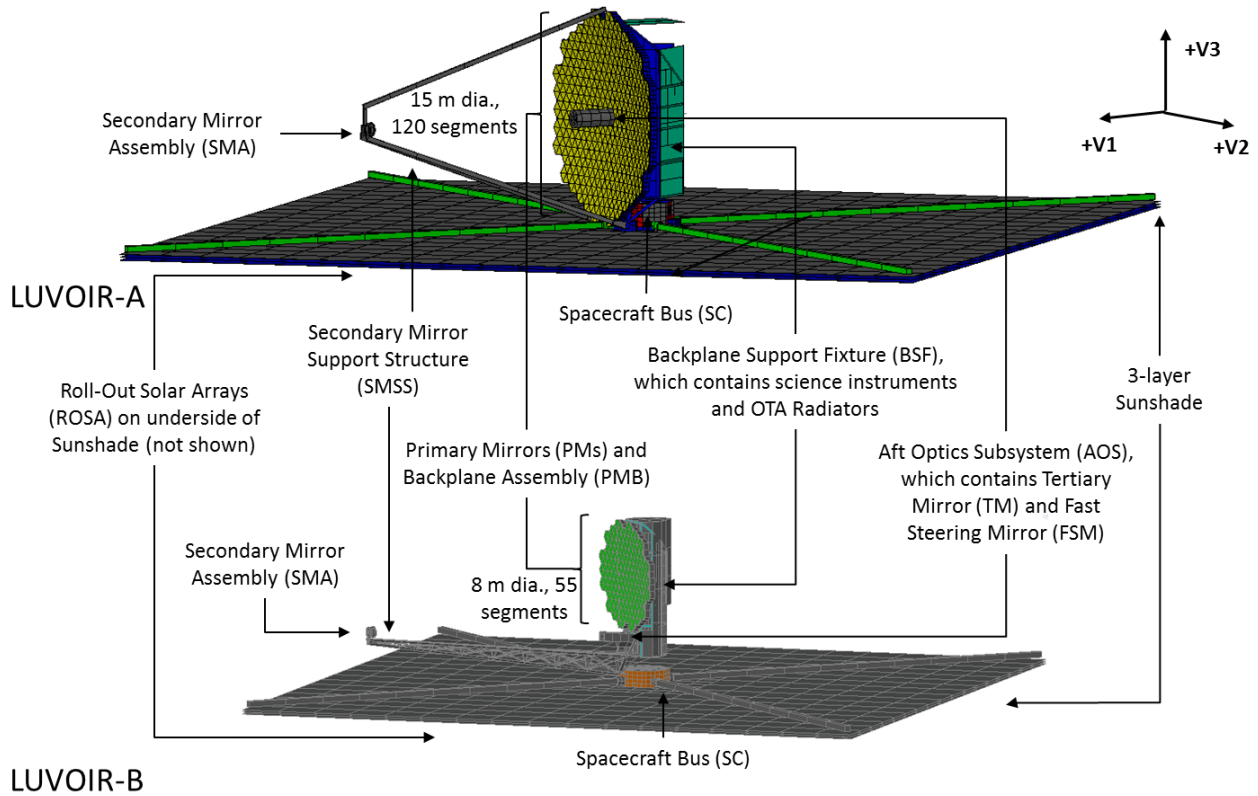

Figure 1. The two LUVOIR concepts, with major components denoted.

The two LUVOIR concepts are shown in Figure 1, with the sizes of each observatory scaled for comparison. The upper “half” of the observatory which performs all of the science of LUVOIR is referred to as the Payload Element, which contains the Optical Telescope Assembly (OTA), the instruments, and the payload articulation system. The major assemblies of the OTA include all of the optical elements and their supporting structures. LUVOIR-A has a primary mirror comprising 120 hexagonal segments, while LUVOIR-B comprises 55 segments. Forward of the primary mirrors, the secondary mirror in LUVOIR-A is supported by a tripodal support structure. In contrast, LUVOIR-B’s secondary mirror support structure (SMSS) is a large deployable truss arm. After light reflects off the primary and secondary mirrors, it reaches the Aft Optics Subsystem (AOS) and travels to the Tertiary Mirror (TM) and Fast Steering Mirror (FSM) before illuminating the instrument pick-off mirrors. To support the primary mirror optical surfaces, the Primary Mirror Backplane Support Structure (PMBSS) is a composite truss structure composed of I-beams on which all of the mirror segments mount. The PMBSS, in turn, is supported by the Backplane Support Frame (BSF), which also contains the entire suite of science instruments.

Mounted onto the V2 sides of the BSF, there are a series of radiators held at 150 K and 250 K, or lower, to control dissipated heat from instrument components and electronics boxes held at 170 K and 270 K, respectively, where ΔT

between the components and the radiators is assumed to be a minimum of 20 K. NIR detectors, at 100 K, transport their heat to the 80 K radiator on the +V3 side of the BSF, as this is the side with the most unobstructed views of deep space and therefore provide the coldest sink temperatures. Since the 150 K and 250 K radiators are relegated to the V2 sides with less favorable views of the deep space sink, they are oversized to account for backloading from the payload and sunshade. The radiators are coated with Ball IR Black (BIRB) paint on their external sides, and have Vapor-Deposited Aluminum (VDA) outer-layer Multi-layer Insulation (MLI) on their internal sides to prevent heat impingement from the warm BSF.

Below the Payload Element, an octagonal spacecraft bus (SC) contains all of the communication, command, data handling, attitude control, power, and propulsion systems. A three-layer sunshade deployed via booms out of the SC blocks solar load from impinging directly on the optical telescope. A roll-out solar array (ROSA) on the underside of the sunshade generates power for the entire observatory. In the axis system defined in the upper right hand corner of Figure 1, and also used as a frame of reference for the remainder of the paper, the +V1 direction is pointed down the boresight of the primary mirror, the +V3 is pointed in the direction of the solar vector, and +V2 completes the right-hand coordinate system.

To acquire its scientific targets, LUVOIR was also designed with the ability to pitch its sunshade towards the sun, as well as pitch and roll the OTA independent of the spacecraft via a Payload Articulation System (PAS) between the BSF and SC. In the LUVOIR convention, the sunshade and spacecraft orientation is described separately from the Payload orientation. The sunshade orientation is taken with respect to the solar vector, where a positive pitch angle describes the sunshade's cant towards the solar vector. The OTA pitch angle denotes the Payload's orientation with respect to the sunshade, not the environment. An OTA pitch of 90° implies that the optical axis of the telescope is parallel to the sunshade, while an OTA pitch of 0° places the optical axis perpendicular to the sunshade. The sunshade pitch can only be positive if the OTA pitch is at 90° . Due to LUVOIR's stable thermal environment at the 2nd Sun-Earth Lagrange Point (SEL2), the thermal worst cases are not defined in a traditional sense as would be in an Earth-observing orbit. Rather, the orientations in Figure 2 describe the bounding extremes for thermal design. In Figure 2(a), a sunshade pitch of 0° and OTA pitch of 90° allows for significant backloading onto the -V3 sides of the Payload components, reducing the overall Payload heater power, and provides the coldest sinks for the +V3 radiator. For Figure 2(b), this orientation allows for sunshade backloading on the -V1 sides of the PMBSS and BSF, but represents a worst-case for the 80 K radiator since it now has a view to the warmer sunshade, and also represents a worst-case in terms of required heater power. Figure 2(c) does not actually result in solar impingement on the OTA, and therefore does not change the heat flux on the optical telescope. However, for the spacecraft bus, this configuration causes the +V1 side to experience much greater environmental loading versus the -V1 side, and therefore impacts the heater power required to hold the bus at 270 K.

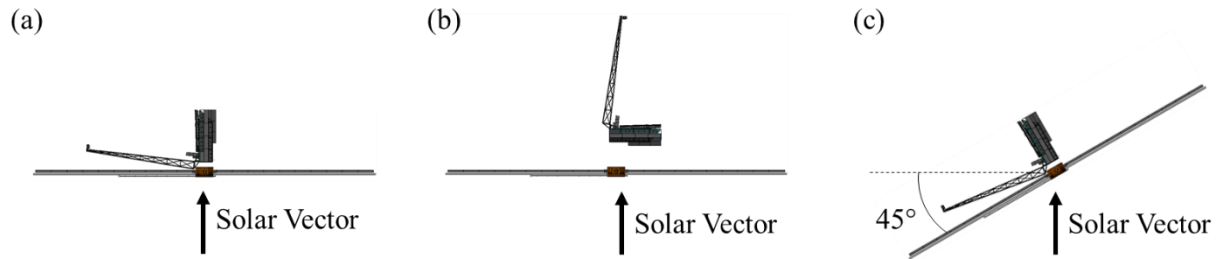

Figure 2. Thermal worst-case operational orientations for LUVOIR

1.2 Instrument Thermal Environment

As mentioned previously, the OTA for both LUVOIR concepts is actively heated to 270 K, with a ± 0.001 K stability requirement on both the composite structure and the mirrors. The composite structure is covered with foil heaters on all surfaces to achieve this requirement, then covered with 20-layer MLI to prevent excess heat loss to space. The MLI has a Black Kapton (BK) outer layer forward of the PMs to reduce stray light to the optics, and VDA outer layer aft of the PMs to minimize radiative heat loss. Figure 3 focuses on the BSF, which serves as a structural hub for the OTA. This component is a truss structure composed of rectangular beams shown in blue framing large rectangular composite shear panels, in red. Also colored in blue are the radiator panels. The truss beams are wrapped with VDA-outer-layer MLI; the panels have VDA-outer-layer MLI facing externally but with BK single-layer insulation (SLI) facing internally to provide a warm sink to the actively-heated instruments. As the BSF structure essentially forms the shape of a hollow tube with its central axis

aligned in the V3 direction, the V3 ends of this tube are covered with MLI with a BK internal-facing layer and VDA external-facing layer to further reduce excess heat loss.

The instruments themselves are embedded within the internal cavity of the BSF. The BSF panels are actively heated to reduce the spatial gradients on the BSF structure, as well as to provide a warm backload on its internal faces, thus reducing the amount of heater power required for the instruments to keep their optical benches at 270 K or above. In addition, the sunshade provides the cold thermal environment around the instrument radiators. It was determined from a trade study that a silicon-doped VDA -V3 side coating, VDA internal layer coatings, and BK +V3 side coating provided the coldest sink temperatures for the instrument radiators, allowing for passive cooling of all of the optics and detectors on each instrument.

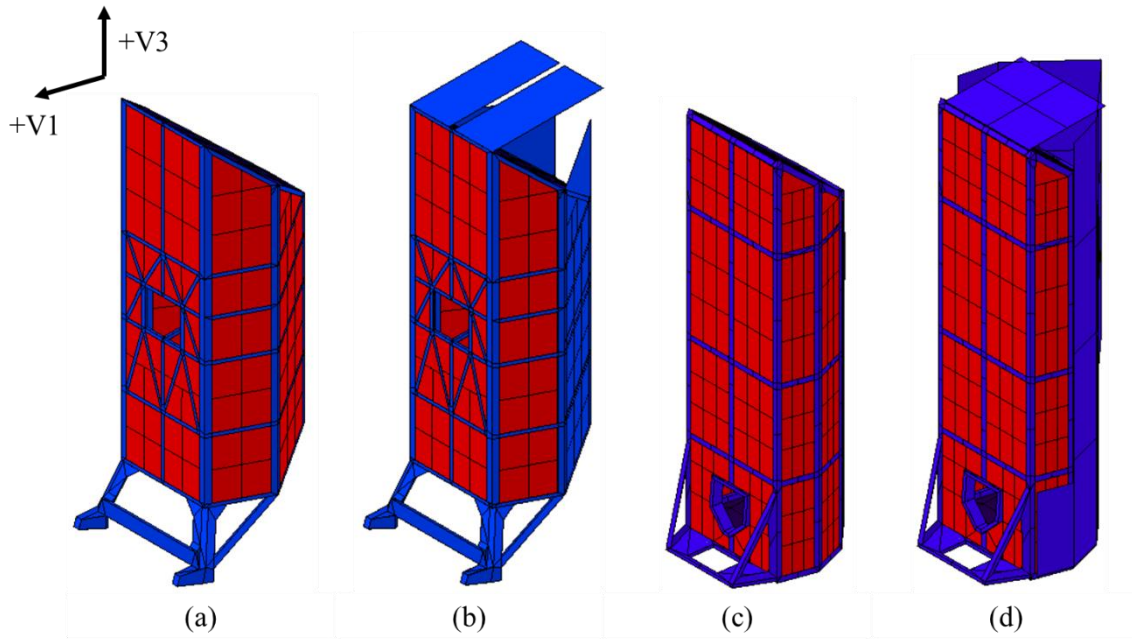

Figure 3. BSF Structure for (a) LUVOIR-A without radiators; (b) LUVOIR-A with radiators; (c) LUVOIR-B without radiators; (d) LUVOIR-B with radiators

1.3 Instruments

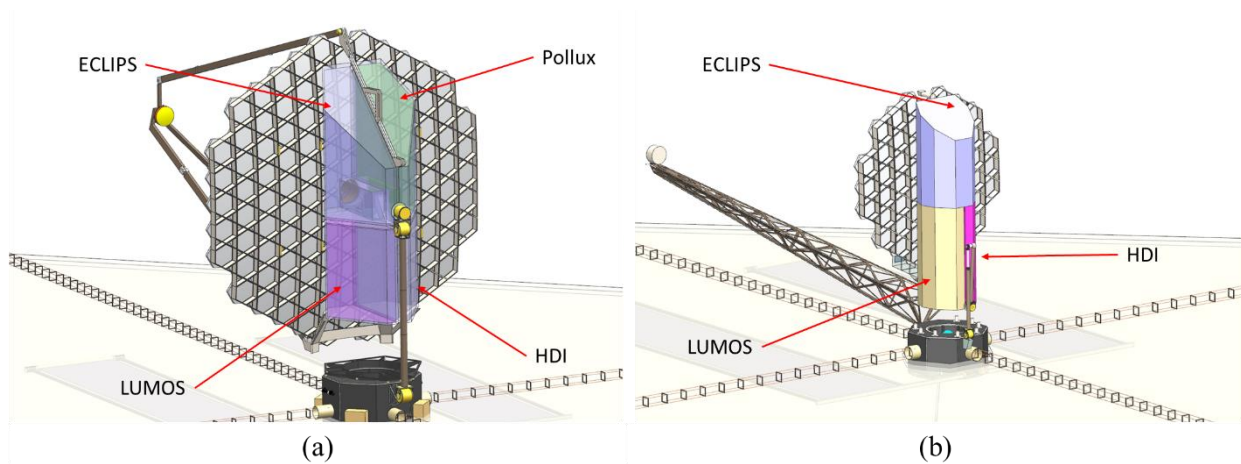

Figure 4. Instrument volumes allocated for (a) LUVOIR-A, (b) LUVOIR-B

Figure 4 illustrates the volumes allocated for each instrument in LUVOIR-A and LUVOIR-B within their respective BSF structures. Three are shared between the LUVOIR concepts: the Extreme Coronagraph for Living Planetary Systems (ECLIPS), which is a near-UV / optical / NIR coronagraph; the LUVOIR UV Multi-object Spectrograph (LUMOS), which provides multi-object imaging spectroscopy in the 100-1000 nanometer range; and the High Definition Imager (HDI), a wide field-of-view near-UV / optical / NIR camera that can also perform astrometry. A fourth instrument is considered for inclusion onto LUVOIR-A that is not present on LUVOIR-B due to mass and volume limitations. Pollux is a far-to-near UV spectro-polarimeter currently being studied by a consortium of European partners, led by the Centre National d'Études Spatiales (CNES)⁵. Through technical exchanges with CNES, the LUVOIR team has confirmed that Pollux's power requirements and instrument design are consistent and compatible with the LUVOIR observatory design. However, the focus of this paper will be on the first three instruments; detailed discussion of Pollux's thermal design is beyond the scope of the current work.

For each instrument to successfully observe at their intended wavelengths, their components are partitioned to separate thermal zones at 100 K, 170 K, or 270 K. Cryogenic nitrogen constant conductance heat pipes (CCHPs) are used for heat transport from the 100 K components to their radiators, whereas 170 K and 270 K components use ethane and ammonia CCHPs, respectively. For serviceability, it was desirable to reduce the number of mechanical interfaces as much as possible between the instruments and the BSF. From a thermal perspective, this is reflected in the reduction of conductive ties from the instruments to the heat pipes. The ammonia, ethane, and nitrogen transport CCHPs are all structurally mounted along their lengths to the BSF bulkhead and beams. A proposed heat transport schematic for LUVOIR-A is shown in Figure 5, which details the paths of each set of instrument heat pipes to BSF radiators. The heat pipes solely travel in the V2/V3 plane as a consideration for observatory testing: when the telescope rests on its -V1 side, the heat pipes are level with respect to the ground. Currently, a greater number of CCHPs travel to the +V2 BSF radiators than the -V2 radiators, since the Pollux heat transport system has not been defined yet. When the heat pipes interface with the instruments, the only mechanical interface is between the instrument heat straps and their respective CCHPs. This approach aims to maximize the heat transport efficiency by minimizing the total number of thermal interfaces between the source and sink of the instrument heat. It also allows for robotic servicing and ease in replacement of the instruments should the necessity arise during LUVOIR's mission lifetime.

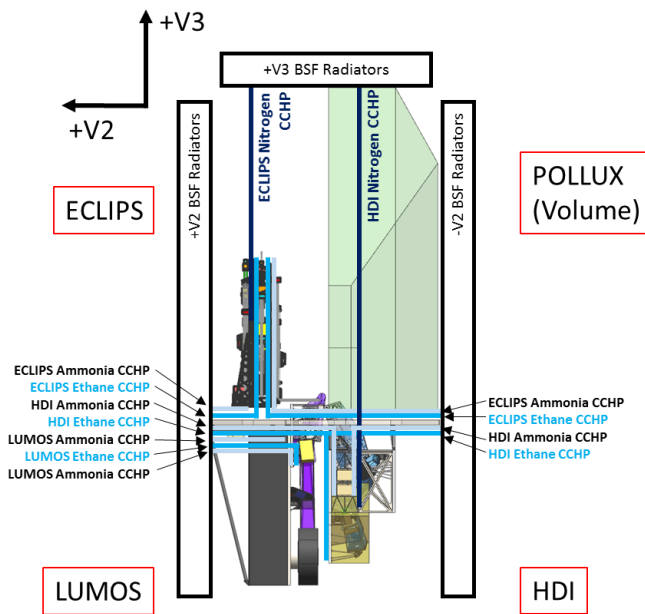

Figure 5. Proposed heat pipe placement on LUVOIR-A

2. ECLIPS THERMAL DESIGN

2.1 Thermal Requirements

ECLIPS is a coronagraph intended to study the diversity of exoplanets and measure the occurrence rate of biomarkers in the atmospheres of rocky planets. As such, it needs to detect a large range of wavelengths from NIR to UV. These detectors and optical components require a large range of temperatures to operate, from 100 K to 270 K. As shown from Figure 6, the incoming beam is split into separate infrared (IR), visible (VIS), and UV channels. The NIR channel has its own optical bench, while the UV and VIS channels share a bench. ECLIPS has eight detectors: the UV imager and low-order wavefront sensor (LOWFS) with temperature requirements of 170 K, the VIS Integral Field Spectrograph (IFS), VIS Imager, VIS LOWFS, and NIR LOWFS at 170 K, and the NIR IFS and NIR single planet spectrograph (SPS) at 100 K. The thermal stability requirement for these detectors is ± 0.5 K.

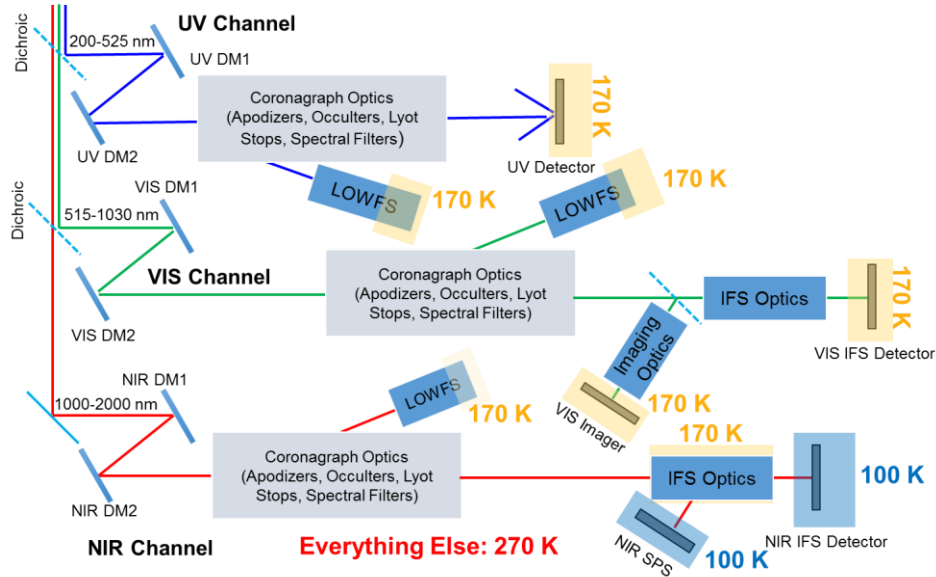

Figure 6. The ECLIPS Instrument optical schematic, including detectors

2.2 Thermal Design Overview

The thermal architecture of the ECLIPS instrument is designed to meet its driving requirements to keep its optical benches heated and stable while cooling its detectors, and their corresponding Front-End Electronics (FEEs) and optical components, to their operational temperatures. The ± 0.5 K stability requirements of ECLIPS allow for optical bench heaters to be software controlled with a thermostatic routine, rather than requiring Proportional-Integral-Derivative (PID) control. Also, since the ECLIPS instrument is housed within the warm 270 K BSF enclosure, the heater power required to maintain its optical benches at 270 K is fairly small. Most optical components are directly mounted to the optical benches and require no additional thermal control. The 270 K FEEs reject their heat via Oxygen-Free High Conductivity (OFHC) copper heat straps connected to ammonia CCHPs, which transport it out to the 250 K radiators on the V2 sides. However, the lower-temperature detectors and FEEs are housed within their own MLI-covered housing and conductively isolated from the bench with standoffs to reduce both radiative and conductive parasitic heat leaks. As for the 170 K UV and VIS detectors, their FEEs, and the NIR LOWFS, these are passively cooled to their operational 170 K temperatures via OFHC heat straps mounted to ethane CCHPs traveling out to the 150 K radiators. On the NIR optical bench, the NIR IFS and SPS channels first have their housing passively cooled via the heat straps and radiators to 170 K to reduce the parasitic heat incident upon the 100 K detectors. Then, the 100 K detectors themselves are strapped to the cryogenic nitrogen CCHPs, which transport heat to the +V3 80 K radiator. There is furthermore a blanket enclosure with a VDA external layer and BK internal layer that envelops the ECLIPS instrument, isolating it from any temporal effects due to heater control on the BSF structure. The thermal design overlaid on an optical block diagram is shown in Figure 7. The mechanical design of ECLIPS is extremely similar between the two LUVOIR concepts, and therefore the sole thermal design presented here meets the requirements of both the A and B instruments.

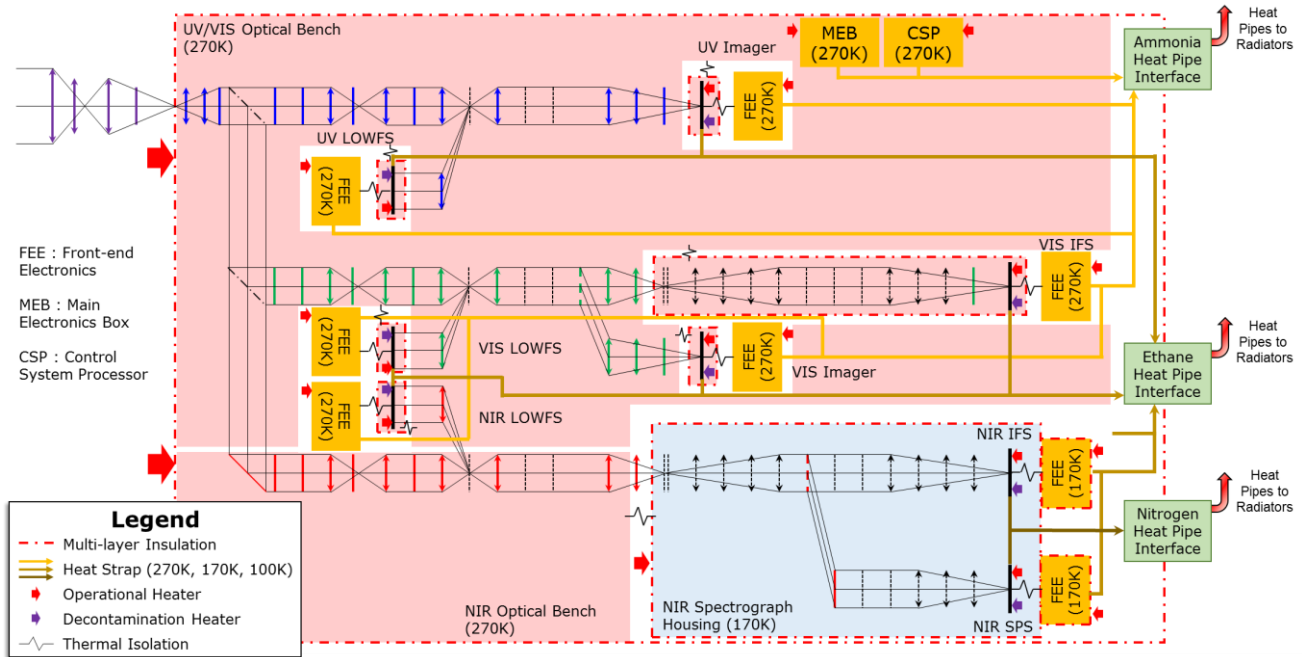

Figure 7. ECLIPS detailed thermal block diagram

3. HDI THERMAL DESIGN

3.1 Thermal Requirements

The High Definition Imager is the primary imaging instrument for LUVOIR, providing high-resolution and wide field-of-view imaging capabilities spanning from the IR to NUV wavelengths. HDI employs two separate channels: a near-ultraviolet and visible (UVIS) channel, and a NIR channel. The UVIS channel employs optics at 270 K and culminates in a focal plane assembly (FPA) and FEE at 170 K, while the NIR requires colder temperatures with optics at 170 K, an FPA at 100 K, and FEE at 170 K. The stability requirements are stringent for the FPAs: ± 0.01 K for the NIR FPA, and ± 0.005 K for the UVIS FPA. However, the other components are more relaxed, only requiring a stability of ± 0.5 K.

3.2 Thermal Design Overview

Similar to the ECLIPS thermal design, the HDI instrument thermal design aims to keep both the optical bench with UVIS components warm and NIR components cold. Three separate zones of thermal control are used: 100 K, which transfers heat to the 80 K radiators; 170 K to the 150 K radiators; and 270 K to the 250 K radiators. The detailed thermal block diagram for HDI-A is shown on the optical layout in Figure 8. Aside from structural differences, the HDI-B design solely differs in optical design by the lack of the fold mirror (FM) past the fast steering mirror (FSM). As seen from the figure, the optical bench beneath the 270 K optical components is actively heated, while the bench supporting the 170 K optics remains uncontrolled and isolated from the actively heated 270 K region. All heaters required PID control to achieve their stability requirements. A series of spreader ammonia heat pipes are also embedded on the 270 K optical bench to reduce spatial gradients.

In the UVIS channel, the optics are mounted on the 270 K portion of the optical bench and passively reach 270 K without any need for active thermal control. The 170 K UVIS FPA is kept in an MLI-wrapped housing with baffling to limit its radiative view to the environment; the housing itself is mounted on titanium standoffs for conductive isolation. Both the UVIS FPA and UVIS FEE are heat-strapped to the ethane heat pipes to reject their parasitic heat and achieve their goal temperatures. For the NIR channel, the optics, detector, filter wheel, and FEE all require cooling. A NIR enclosure MLI tent is placed over the entire NIR channel optical assembly to limit their radiative view to the 270 K optical bench and components. The NIR filter wheel, NIR mirrors 1 through 3, and NIR FEE are each heat-strapped to the ethane CCHPs to cool to 170 K. The NIR FPA requires additional MLI-insulated housing and baffling to reduce its radiative parasitics, as well as titanium standoffs to the bench and G-10 isolation between the detector and its 170 K FEE to limit

the amount of conductive heat leak. For the HDI-A NIR detector housing, solely MLI insulation is enough to reduce the NIR detector parasitics to acceptable levels. However, for the HDI-B NIR detector housing, a thermal strap to the 170 K ethane heat pipe is necessary to actively cool the housing and reduce the parasitics on the 100 K NIR detector. The main electronics box (MEB), being a high-power component, is directly interfaced to the ammonia CCHPs to reject its significant waste heat without the need for thermal straps. The whole HDI assembly is also enclosed inside a VDA external layer and BK internal layer MLI enclosure, which isolates it from cross-talk between other instruments and the BSF heater control.

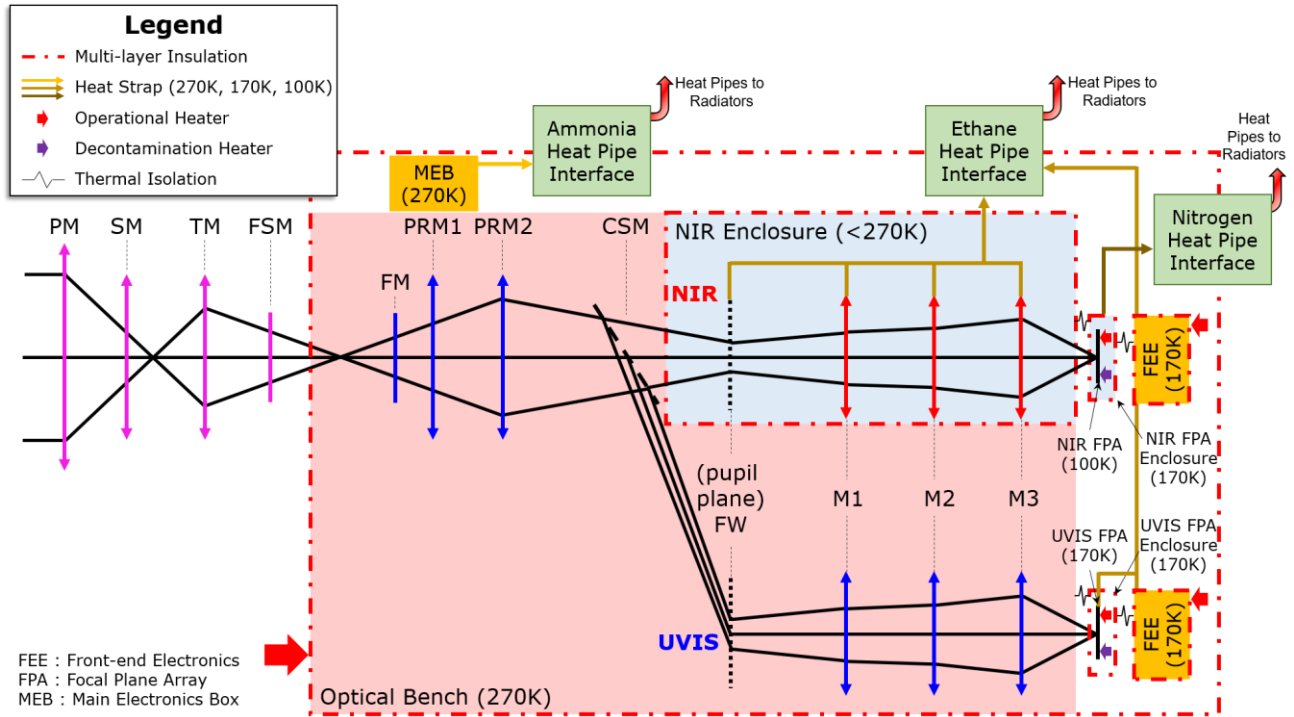

Figure 8. HDI Detailed Thermal Block Diagram

4. LUMOS THERMAL DESIGN

4.1 Thermal Requirements

The LUVOIR Ultraviolet Multi-Object Spectrograph (LUMOS) is the primary ultraviolet instrument for LUVOIR, allowing it to investigate the flow of matter and energy between the intergalactic medium and circumgalactic media. Due to the short wavelengths that it observes, the detectors and optical components for this instrument occupy a smaller range of temperatures than the HDI or ECLIPS instruments, requiring control between 170 K and 280 K. The 280 K requirement derives from the desire for contaminants to condense on the surrounding structure rather than the LUMOS optics. Therefore, it places LUMOS at 10 K warmer than the optical benches of the other instruments, necessitating more overall heater power. However, there is also a less-stringent stability requirement for LUMOS: while the near-ultraviolet (NUV) detector assembly has a need for ± 0.1 K stability, requiring PID heater control, all other components can operate with ± 3 K and only necessitate software control with a thermostatic routine.

4.2 Thermal Design

For LUMOS, the incoming beam is split into a NUV/VIS multi-object spectrograph (MOS) channel, a far-ultraviolet (FUV) MOS channel, and a FUV Imager channel. The detailed thermal block diagram for LUMOS-A is shown on the optical layout in Figure 9. The intervening optics before the detectors are all kept at the same temperature as the optical bench and therefore do not require additional thermal hardware for control. The imager and FUV detectors and their FEEs are also kept at 280 K, and are heat-strapped with OFHC copper to the ammonia heat pipe. A separate series of ammonia

heat pipes directly interface with the MEB, LUMOS Microshutter Control Electronics (LMCE), High-Voltage Power Source (HVPS), and Micro-Shutter Array (MSA) heat straps to carry their waste heat out to the 250 K radiator. The NUV detector at 170 K is both conductively isolated via a titanium standoff to the bench, as well as heat strapped to the ethane heat pipes. It is furthermore conductively isolated from its 280 K FEE so as to reduce the amount of conductive parasitic. While optically the LUMOS-A and LUMOS-B designs differ significantly, the thermal designs are similar except for changes due to the placement and physical size of the components that require thermal control. There is also a VDA external layer and BK internal layer MLI enclosure which wraps around the entire LUMOS assembly. This isolates it from cross-talk with the other instrument heaters and the BSF heater panels, and also prevents excessive heat loss from the LUMOS optical bench, at 10 K higher than the surrounding environment.

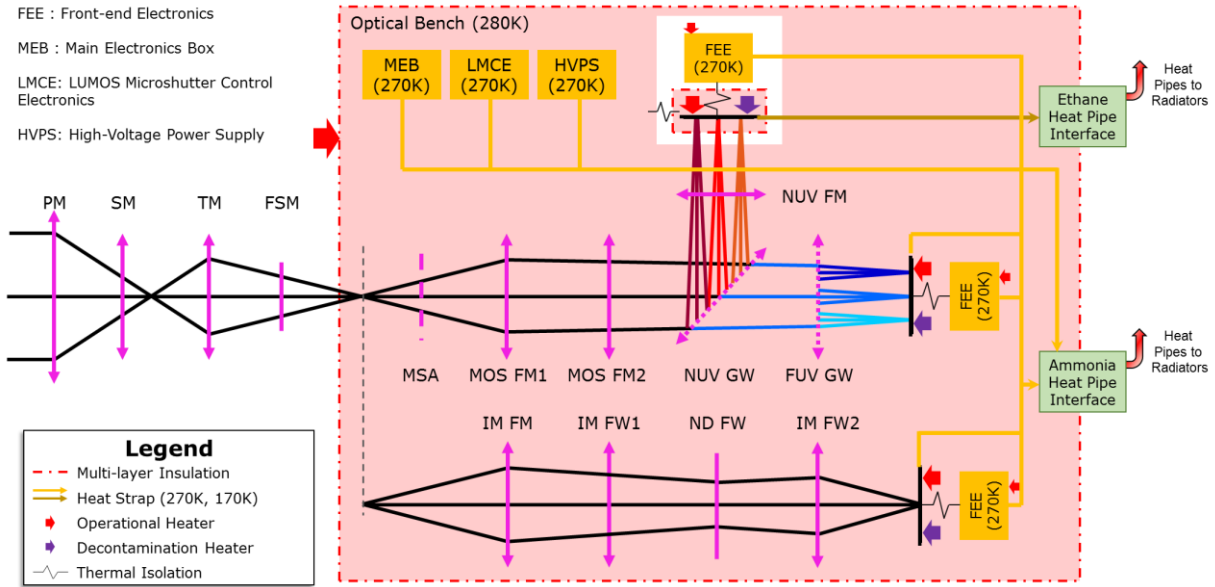

Figure 9. LUMOS-A Detailed Thermal Block Diagram

5. PRELIMINARY THERMAL ANALYSIS

Simplified thermal models for each instrument were built into the existing LUVOIR-A and LUVOIR-B thermal system models in the Thermal Desktop analysis software. These models included simplified representations of the optical bench and instrument structure with surface areas matched to the structural CAD model to estimate heater power accurately. Critical detector surfaces, detector housing, optical components, and front-end electronics boxes were also modeled to estimate the parasitic heat on these components for thermal strap sizing. To conservatively size the radiators at this conceptual phase, the 170 K component parasitics have a margin of 50% added, while for the 100 K component parasitics⁶, a margin of 100% is added. For the heater powers, a 40% uncertainty margin is included in the predictions⁷. The results from the preliminary thermal analysis are shown in Table 1 for heater power estimates, and Table 2 for heat strap mass estimates and radiator sizing. Note all of the numbers presented reflect the worst-case values for each instrument based on the three orientations presented in Figure 2.

Table 1. Preliminary Estimates of LUVOIR Instrument Heater Powers

	ECLIPS-A	ECLIPS-B	LUMOS-A	LUMOS-B	HDI-A	HDI-B
Operational Heater Power for Electronics Boxes and Optical Components (W)	23.5	23.5	88.2	77.5	29.4	8.2
Operational Heater Power for Optical Benches (W)	28.4	28.4	109.0	77.0	49.3	28.2
Decontamination Heater Power (W)	6.4	6.4	76.4	61.8	56.7	22.9
Survival Heater Power (W)	58.4	58.4	331.7	221.7	112.1	44.4

From Table 1, it is interesting to note that the operational heater powers calculated for the optical benches are relatively small when considering the sizes of these benches, many of which occupy multiple square meters of surface area each. This implies that the bench heaters do not require much power consumption to achieve their operational setpoints, as a benefit of the warm sink temperatures provided by the BSF heaters. For electronics boxes and optical components, these heater powers were estimated based on the operational temperatures that were desired on each respective component and to compensate for heat lost to the radiators if the boxes weren't dissipating at their peak value. The decontamination heaters are sized to drive the detectors as high as 330 K to remove contaminants. In addition, the survival heaters are sized with the consideration for keeping both the optical benches and the electronics boxes above their survival temperatures of 253 K, especially in the case where the instrument electronics are not dissipating.

Table 2. Preliminary Estimates of LUVOIR Instrument Radiator Sizes and Heat Strap Masses

	ECLIPS-A	ECLIPS-B	LUMOS-A	LUMOS-B	HDI-A	HDI-B
Total Heat to 80 K Radiator (W)	0.3	0.3	--	--	3.2	3.1
Total Heat to 150 K Radiator (W)	14.0	14.0	36.3	11.9	68.0	48.0
Total Heat to 250 K Radiator (W)	407.4	407.4	329.3	238.9	99.9	96.0
Total 80 K Instrument Radiator Area (m ²)	0.3	0.2	--	--	4.1	2.2
Total 150 K Instrument Radiator Area (m ²)	0.8	1.1	2.1	0.9	4.0	3.7
Total 250 K Instrument Radiator Area (m ²)	2.1	2.1	1.7	1.2	0.5	0.5
Total Heat Strap Mass (kg)	32.1	32.1	43.8	29.2	25.8	19.3

In Table 2, the total heat values being transported to each radiator zone, the corresponding radiator area required to dissipate this heat, and the total heat strap mass to tie the components to their respective transport heat pipes are shown per instrument. As mentioned previously, the 80 K radiators are facing out from the +V3 side, while the 150 K and 250 K radiators are facing out from the V2 sides. For the 100 K components transporting their heat to the 80 K radiator, their dissipations are minimal and the bulk of the heat stems from radiative parasitics on the cold detectors from the warm environment. LUMOS does not have 100 K components, so its total heat to the 80 K radiators is omitted from this table. Due to the orientation requirements of LUVOIR, the maximum sink temperatures on the +V3 radiators are not significantly colder than the radiator temperature as would be desired, since an OTA pitch of 0° results in significant backloading on the 80 K radiator at the “top” of the BSF. Therefore, a large radiator area is needed to reject small amounts of heat from the 100 K components. For the 170 K and 270 K components, while the sink temperatures on the V2 sides are higher, these radiators also have a larger ΔT to their sink and therefore require smaller areas to dissipate greater amounts of heat. Also, as these radiators have a “side” view out of the BSF, their sink temperatures also do not experience drastic swings with OTA pitch change.

For the HDI and ECLIPS instruments, a trade study was performed on each instrument to examine the benefits of cooling the optical benches supporting the entire NIR optical assembly, rather than just those optical components which required colder temperatures. It was thought that cooling these NIR benches to 170 K would almost eliminate the radiative and conductive parasitics on the 170 K components, and drastically reduce the parasitic loads on the 100 K detectors. However,

while the optical components and detectors viewing NIR wavelengths did see reductions in parasitics from cooling the NIR optical benches, it was found for both instruments that cooling these benches to 170 K placed enormous heat loads on the 150 K radiators, resulting in five times greater heat load for HDI, and almost 180 times greater heat load for ECLIPS than the baseline design of just cooling the 100 K and 170 K components. Therefore, it is not a sensible tradeoff to cool the optical benches below the NIR optical assemblies. However, the benefits from reducing radiative parasitics on the 100 K detectors are not overlooked, and it is in this spirit that the detector housings for the 100 K detectors are passively cooled to 170 K. This drastically reduces the load on the 80 K radiators, and while it increases the load for the 150 K zone, the radiator sizes for this zone do not increase greatly with this extra load due to the larger temperature difference between source and sink.

6. CONCLUSION AND RECOMMENDATIONS

Designs for active and passive thermal control of the proposed LUVOIR instruments for each observatory concept have been presented in the current work. The instruments are designed to inhabit the proposed system-level framework of the payload element, where they are enclosed within the warm environment of the actively-heated BSF. Each instrument has an MLI outer layer to reduce their cross-talk to each other and limit temporal effects due to BSF panel heater control. A series of heaters on each instrument drive components and optical benches to their operational temperatures, and each thermal zone within the instruments have their own dedicated transport heat pipes to their corresponding radiators. As expected, LUVOIR-A requires significantly more heater power and radiator area than LUVOIR-B, but these parameters do not simply scale by size difference between the two observatories as the instruments in each concept occupy different BSF thermal environments from each other.

Should LUVOIR be selected by the Astro2020 Decadal Committee for further development, a series of thermal challenges must be addressed through in-depth studies. The parasitic heat to the transport heat pipes, especially for the colder thermal zones, must be quantified in detail, and increased scrutiny must be applied to minimize the amount of unwanted heat flow into to each zone. The heat transport design needs to be matured to where colder components have an efficient conductive path directly to their radiators without requiring a large ΔT from source to sink. Also, regarding the heat straps from the components to the heat pipes, it is currently assumed that each heat strap is clamped to its heat pipe with thermal interface material to facilitate heat transfer. However, further studies need to be completed to delineate the method for which these thermal straps attach to the heat pipe interfaces while remaining serviceable. Given the dimensions on both LUVOIR-A and LUVOIR-B, and hence long heat transport distances, this presents an enormous challenge to keep the ΔT to the assumed value of 20 K from instrument to radiator.

In addition, verification of the thermal design is critical to the success of LUVOIR. The size of both concepts and the stability requirements necessary to meet science goals make a comprehensive test campaign essential to prove the operability and robustness of the design. The instruments need to be tested not just at an instrument assembly level, but at a systems level installed within the BSF structure to quantify the amount of cross-talk between the instruments and the structure. It may also not be possible to test LUVOIR as a fully-integrated system with the OTA, sunshade, and SC, so capturing the correct environment and interfaces with ground support equipment around the BSF may be crucial to understand how well the integrated LUVOIR thermal design works. Finally, while the heat pipes are all arrayed in the V2 and V3 plane so that they can be ground-tested when the spacecraft is oriented so that the -V1 side faces downwards, heat pipe levelness is paramount, and extensive thermal analysis and test planning will need to be performed to conceptualize the test design and ensure that it simulates a flight-like condition.

LIST OF ACRONYMS

<i>AOS</i>	= Aft Optics System
<i>BK</i>	= Black Kapton coating
<i>BSF</i>	= Backplane Support Frame
<i>CCHP</i>	= Constant Conductance Heat Pipe
<i>CSM</i>	= Channel Select Mechanism
<i>CTE</i>	= Coefficient of Thermal Expansion
ΔT	= Change in temperature
<i>DM</i>	= Deformable Mirror

<i>ECLIPS</i>	= Extreme Coronagraph for Living Planetary Systems
<i>FC</i>	= Field Corrector
<i>FEE</i>	= Front-End Electronics
<i>FPA</i>	= Focal Plane Assembly
<i>FPM</i>	= Focal Plane Mask
<i>FM</i>	= Fold Mirror
<i>FSM</i>	= Fast Steering Mirror
<i>FUV</i>	= Far Ultraviolet
<i>FW</i>	= Filter Wheel
<i>GSFC</i>	= NASA Goddard Space Flight Center
<i>GW</i>	= Grating Wheel
<i>HDI</i>	= High Definition Imager
<i>HVPS</i>	= High-Voltage Power Source
<i>IFS</i>	= Integral Field Spectrograph
<i>IM</i>	= Imager Mirror
<i>IR</i>	= Infrared
<i>IS</i>	= Image Surface
<i>LMCE</i>	= LUMOS Microshutter Control Electronics
<i>LOWFS</i>	= Low-Order Wavefront Sensor
<i>LUMOS</i>	= LUVUOIR Ultraviolet Multi-object Spectrograph
<i>LUVUOIR</i>	= the Large Ultraviolet/Optical/Infrared Surveyor
<i>K</i>	= Kelvin
<i>m</i>	= Meter
<i>MEB</i>	= Main Electronics Box
<i>MLI</i>	= Multi-Layer Insulation
<i>MOS</i>	= Multi-Object Spectrograph
<i>MSA</i>	= Micro-Shutter Array
<i>NASA</i>	= National Aeronautics and Space Administration
<i>ND</i>	= Neutral Density
<i>NIR</i>	= Near-Infrared
<i>NUV</i>	= Near-Ultraviolet
<i>OAP</i>	= Off-Axis Parabola
<i>OFHC</i>	= Oxygen-Free High Conductivity copper
<i>OTA</i>	= Optical Telescope Assembly
<i>PAS</i>	= Payload Articulation System
<i>PID</i>	= Proportional-Integral-Derivative Control
<i>PDU</i>	= Power Distribution Unit
<i>PM</i>	= Primary Mirror(s)
<i>PMBSS</i>	= Primary Mirror Backplane Support Structure
<i>PR, PRM</i>	= Pupil Relay, Pupil Relay Mirror
<i>RM</i>	= Relay Mirror
<i>ROSA</i>	= Roll-Out Solar Array
<i>SC</i>	= Spacecraft
<i>SLI</i>	= Single-Layer Insulation
<i>SM</i>	= Secondary Mirror
<i>SMSS</i>	= Secondary Mirror Support Structure
<i>SPS</i>	= Single Planet Spectrograph
<i>TM</i>	= Tertiary Mirror
<i>ULE</i>	= Ultra Low Expansion glass
<i>UV</i>	= Ultraviolet
<i>UVIS</i>	= Ultraviolet /Visible
<i>VDA</i>	= Vapor-Deposited Aluminum coating
<i>VIS</i>	= Visible light
<i>W</i>	= Watt(s)

REFERENCES

- [1] Bolcar, M. R. et al. "The Large UV/Optical/Infrared Surveyor (LUVOIR): Decadal Mission Study Update." Proc. SPIE 10698. (2018)
- [2] Park, S. C. et al. "LUVOIR Thermal Architecture Overview and Enabling Technologies for Picometer-Scale WFE Stability." IEEE Aerospace Conference, 05.0305. (2019)
- [3] The LUVOIR Science and Technology Definition Team. "The LUVOIR Mission Concept Study Final Report." <https://asd.gsfc.nasa.gov/luvoir/>. To be submitted August 23rd, 2019.
- [4] Yang, K. et al. "The Large UV/Optical/Infrared Surveyor Decadal Mission Concept Thermal System Architecture." International Conference on Environmental Systems ICES-2019-312. (2019)
- [5] Muslimov, E. R. et al. "POLLUX: a UV spectropolarimeter for the future LUVOIR space telescope," Proc. SPIE, 10699-05. (2018)
- [6] Peabody, H. and Peabody, S. "Gaps in Thermal Design Guidelines in the Goddard Space Flight Center GOLD Rules." International Conference on Environmental Systems ICES-2018-268. (2018)
- [7] "Goddard Space Flight Center Rules for the Design, Development, Verification, and Operation of Flight Systems." NASA GSFC-STD-1000G. (2016)