



Optical Instrument Thermal Control on the Large Ultraviolet/Optical/Infrared Surveyor

Kan Yang, NASA GSFC

Matthew Bolcar, NASA GSFC

Julie Crooke, NASA GSFC

Jason Hylan, NASA GSFC

**Sang Park, Harvard Smithsonian
Center for Astrophysics**

Regis Venti, NASA GSFC

Bryan Matonak, NASA GSFC

Michael Choi, NASA GSFC

SPIE Optics + Photonics 2019

12 August 2019

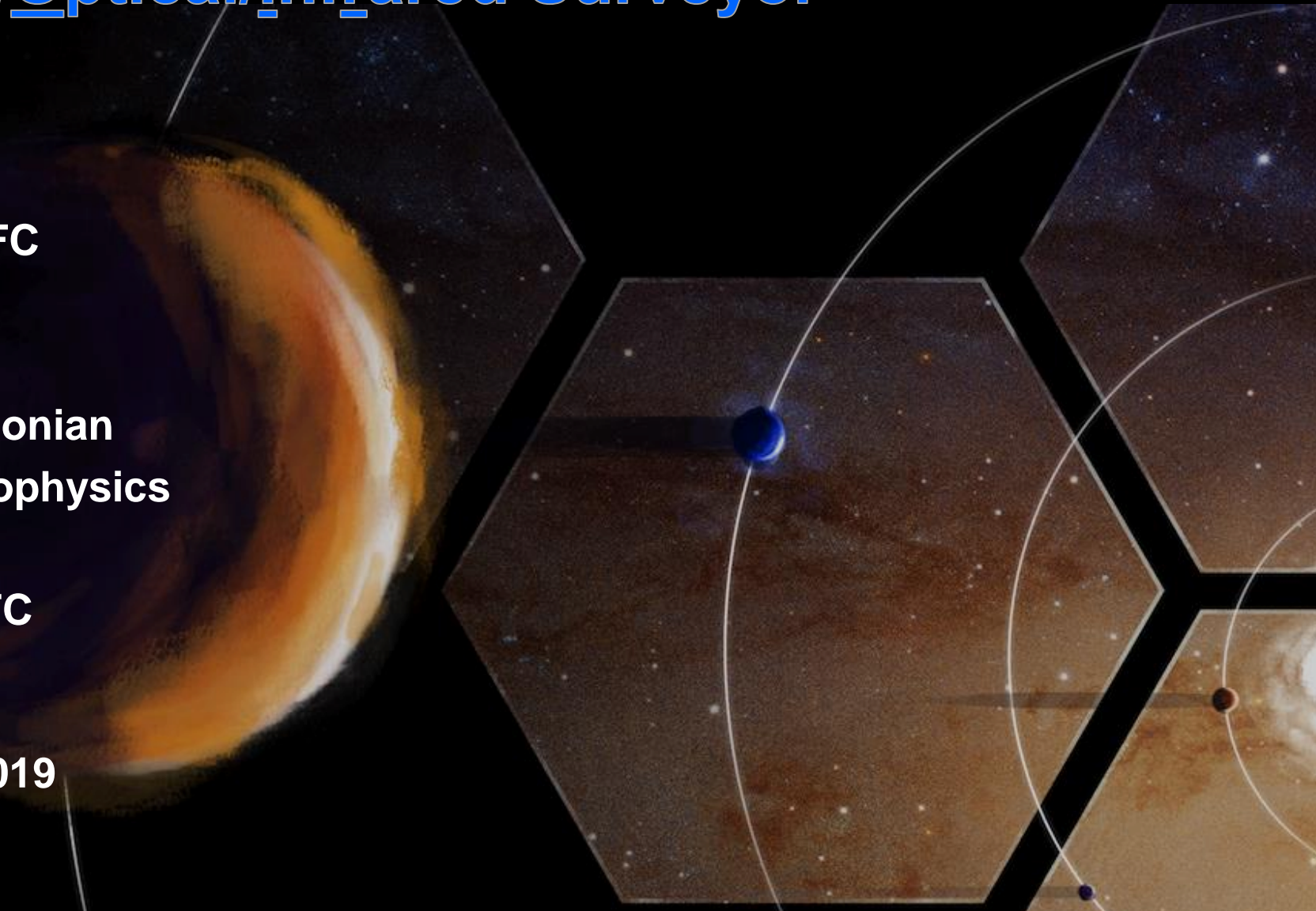

What is LUVOIR?



- The Large Ultraviolet/ Optical/ Infrared Surveyor (LUVOIR) is a multi-wavelength general-purpose space observatory
 - One of four concept studies for the 2020 Decadal Survey in Astronomy / Astrophysics
- LUVOIR enables broad range of astrophysics to be performed:
 - Galaxy and planet evolution
 - Star and planet formation
 - Exoplanet atmospheric and surface composition (assessing habitability, biosignatures) to answer question “are we alone?”
- LUVOIR operates at Sun-Earth Lagrange Point 2 orbit

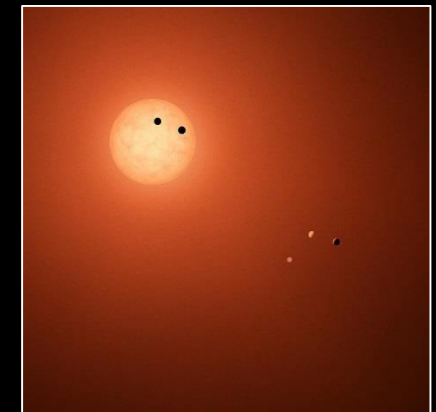
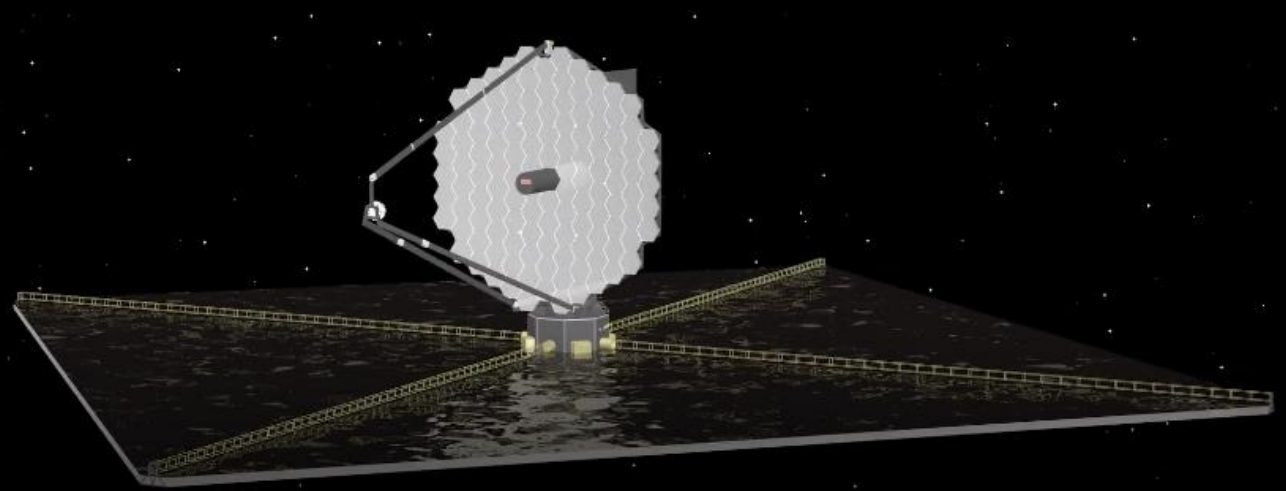

LUVOIR's Instruments

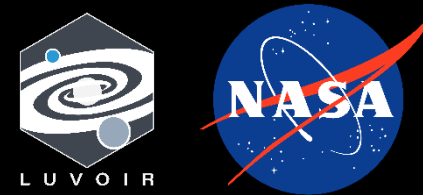

- **Extreme Coronagraph for Living Planetary Systems (ECLIPS):** Coronagraph with imaging, integral-field spectroscopy, and point-source spectroscopy capabilities
 - 200 nm – 2.0 μm bandpass; Ultraviolet (UV), Visible (VIS), Near-Infrared (NIR) channels
- **High Definition Imager (HDI):** wide field-of-view camera with Imaging, GRISM Spectroscopy, Fine Guiding, Phase Retrieval, and Astrometric capabilities
 - 200 nm – 2.5 μm bandpass, UV/VIS, Near-IR channels
- **LUVOIR UV Multi-Object Spectrograph (LUMOS):** multi-object spectroscopy and imaging
 - 100 nm – 1.0 μm bandpass; Far-UV, Near-UV, VIS channels
- **Pollux:** spectropolarimetry and pure spectroscopy capabilities (Centre National d' Etudes Spatiales)
 - 100 nm – 390 nm bandpass; Far-UV, Mid-UV, Near-UV channels

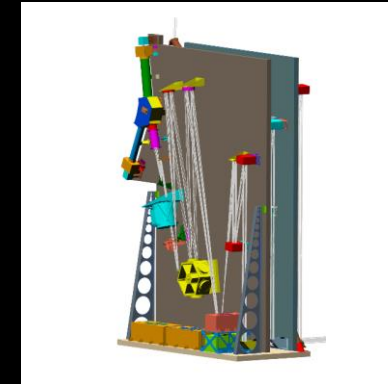

ECLIPS

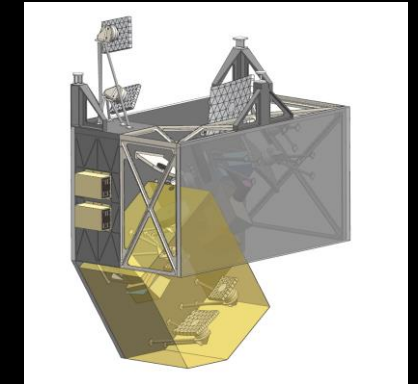

HDI

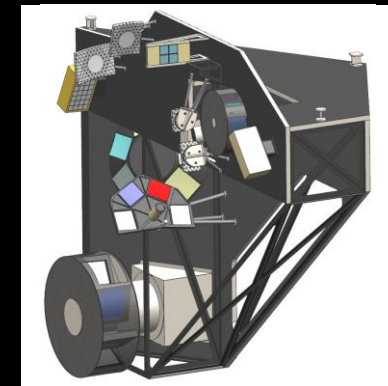

LUMOS

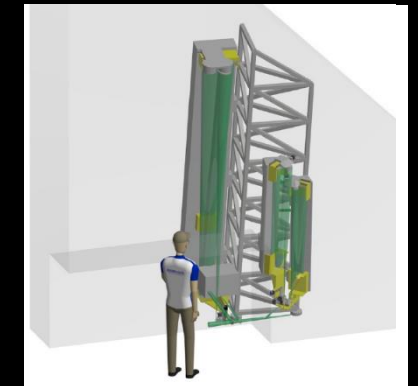

Pollux

Two LUVOIR Concepts

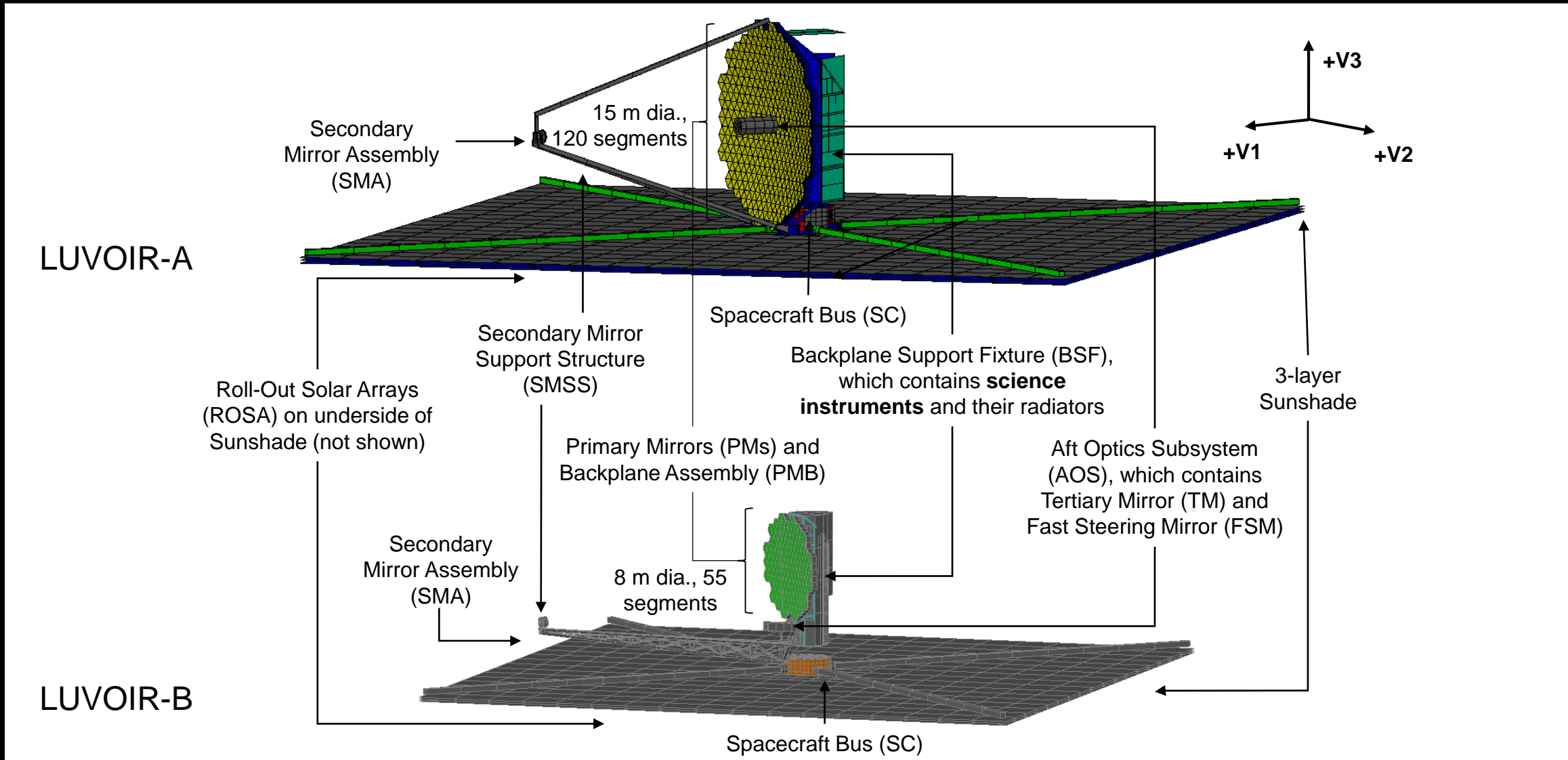

Instrument Layout

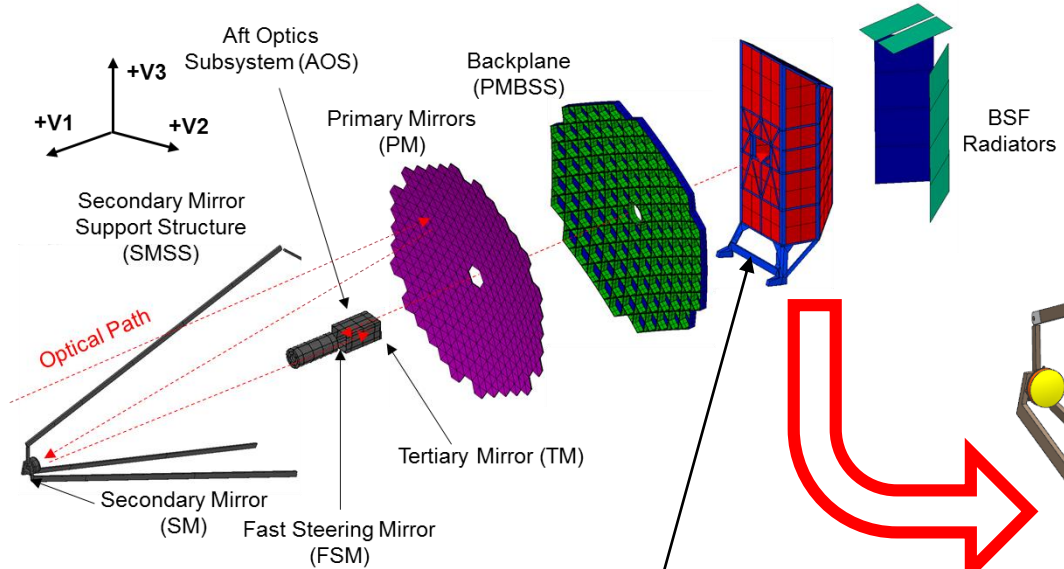

*LUVOIR-A Optical Telescope Assembly shown, but LUVOIR-B assembly is very similar

- BSF (Backplane Support Fixture)**
- Composite truss structure: Vapor Deposited Aluminum (VDA) outer-layer MLI
 - Composite Shear Panels: VDA-outer-layer MLI on external-facing surfaces, Black Kapton (BK) Single-Layer Insulation (SLI) internal-facing surfaces
 - Foil heaters covering all surfaces

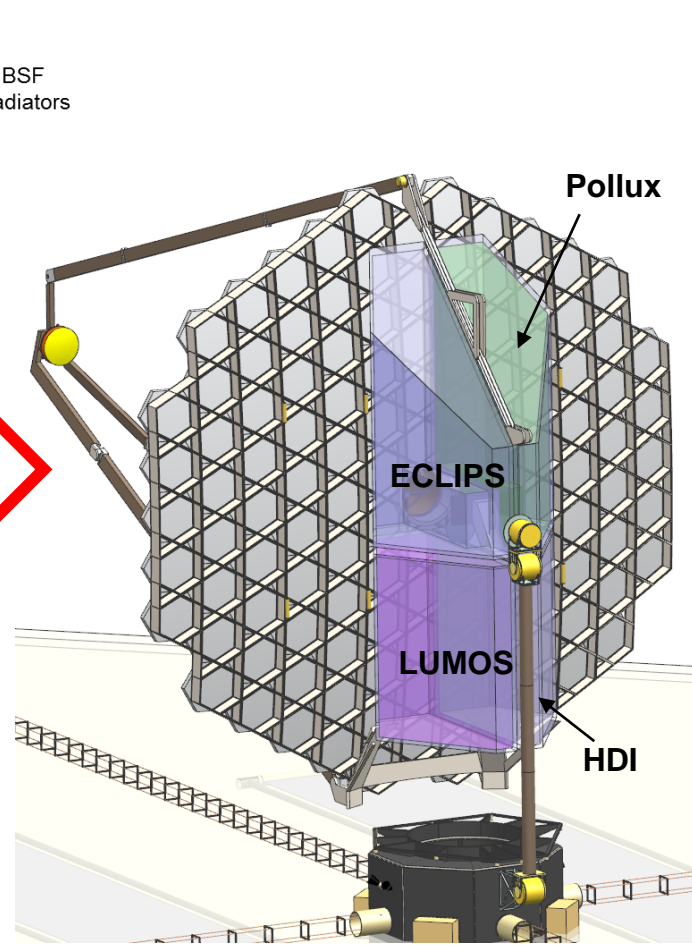

LUVOIR-A

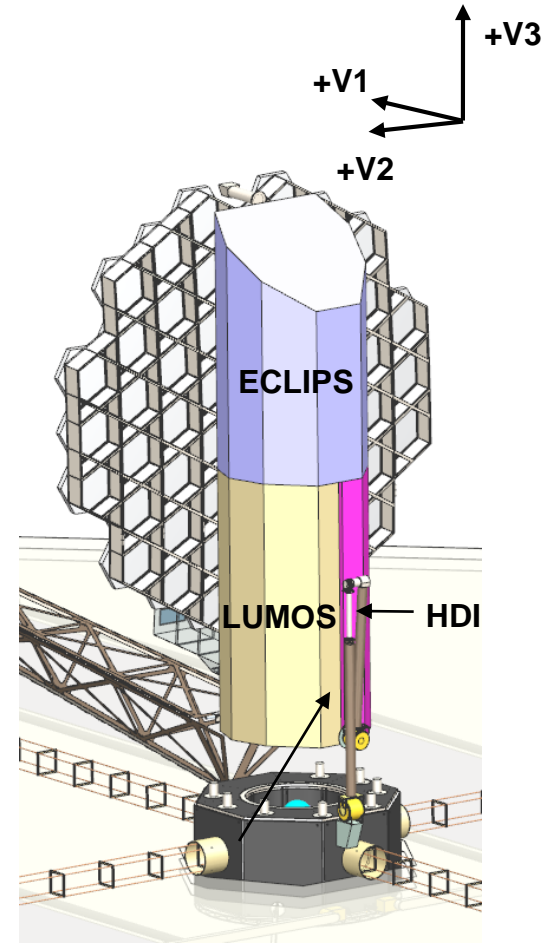

LUVOIR-B

Instrument Thermal Design Requirements

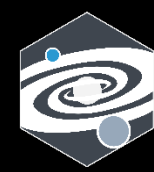

	ECLIPS	HDI	LUMOS
270 K - 280 K Zone Components	Optical Benches, UV/VIS Front End Electronics (FEE); Main Electronics Box (MEB), Control System Processor (CSP) (all 270 K)	UV/VIS Optical Bench and components; MEB (all 270 K)	Optical Bench; FUV: Multi-Object Spectrograph (MOS), Imager, FEEs; MEB, Microshutter Array (MSA), LUMOS Microshutter Control Electronics (LMCE), High-Voltage Power Source (HVPS) (all 280 K)
270 K Zone Temperature Stability	± 0.5 K benches and FEEs; ± 1 K electronics	± 0.5 K benches; no requirement for electronics	± 3 K FUV and benches; no requirement for electronics
170 K Zone Components	NIR Low-Order Wavefront Sensor (LOWFS); VIS: Imager, LOWFS, Integral Field Spectrograph (IFS); UV: Imager, LOWFS; all NIR FEES	NIR: FEE, Filter Wheel (FW), and mirrors; UV/VIS: Focal Plane Assembly (FPA) and FEE	NUV MOS
170 K Zone Temperature Stability	± 0.5 K	± 0.005 K UV/VIS FPA, ± 0.5 K all others	± 0.1 K
100 K Zone Components	NIR IFS, NIR Single Planet Spectrograph (SPS)	NIR FPA	--
100 K Zone Temperature Stability	± 0.5 K	± 0.01 K	--

Instrument Thermal Design Overview



- Optical benches are actively heated
 - Instruments reside in a warm sink environment provided by the actively-heated BSF panels
- Components reject their heat with Oxygen-Free High Conductivity (OFHC) copper heat straps, which interface with Constant Conductance Heat Pipes (CCHPs) to transport heat to the radiators
 - 100 K components use Nitrogen CCHPs to 80 K radiator on +V3 side of BSF
 - 170 K components use Ethane CCHPs to 150 K radiator on $\pm V2$ sides of BSF
 - 270 K components use Ammonia CCHPs to 250 K radiator on $\pm V2$ sides of BSF
 - All heat pipes arrayed in V2/V3 plane for ease of testing
- Blanket tent around each instrument
- Detectors are cold-biased and actively heated
- Decontamination heaters for each detector

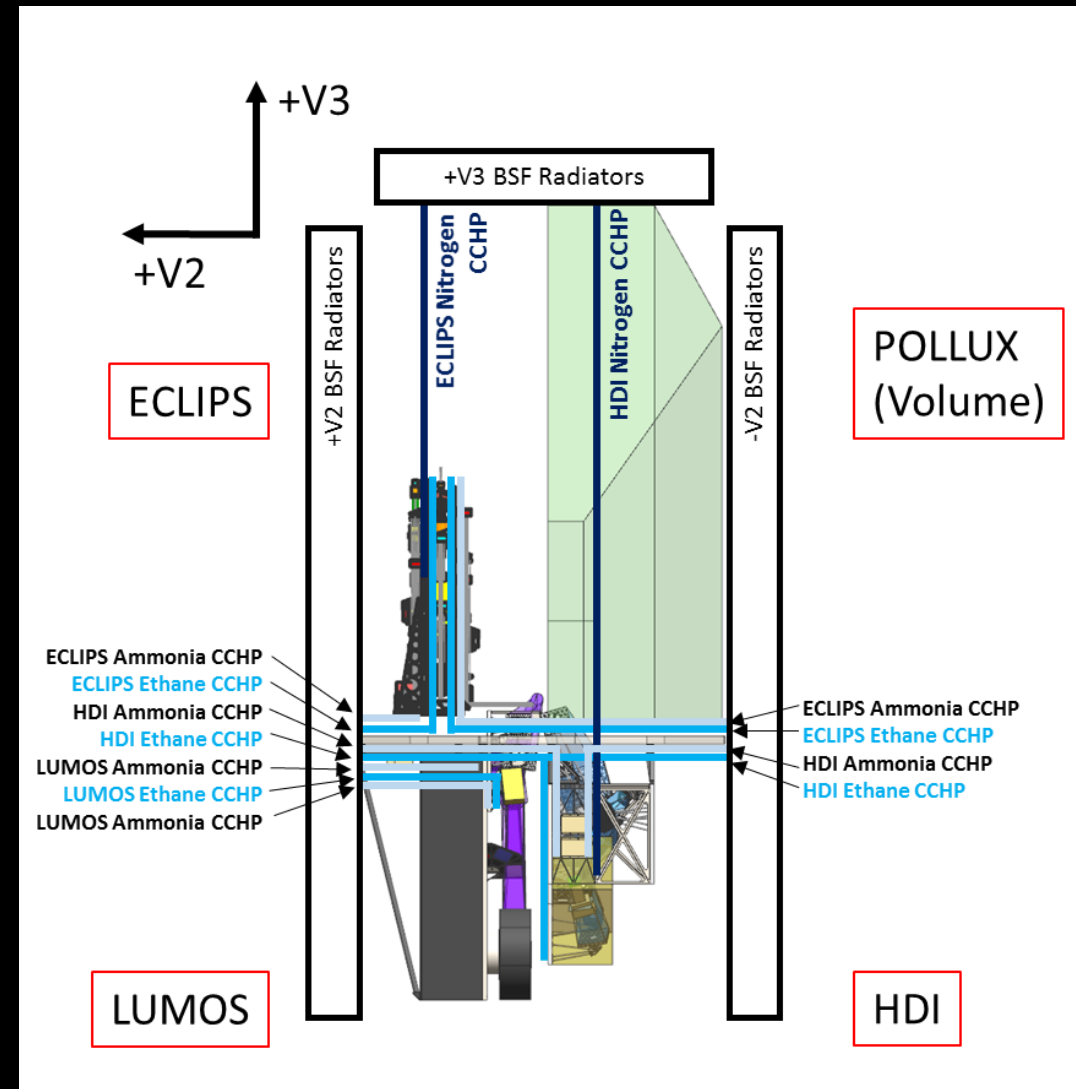

ECLIPS Detailed Thermal Block Diagram

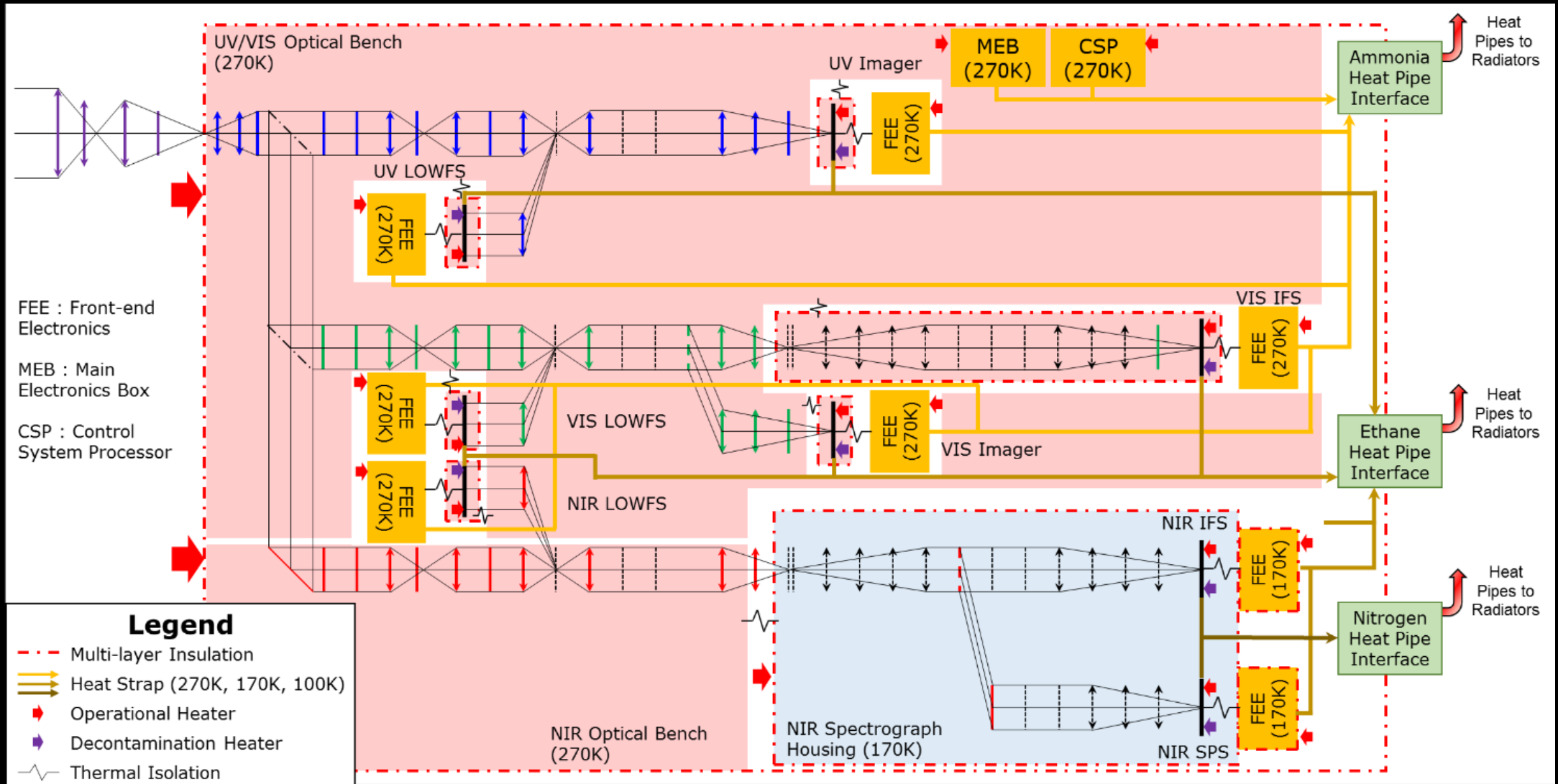
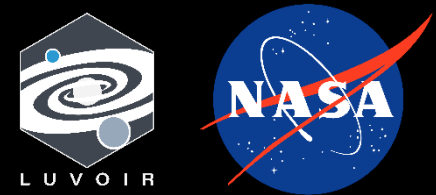

HDI Detailed Thermal Block Diagram

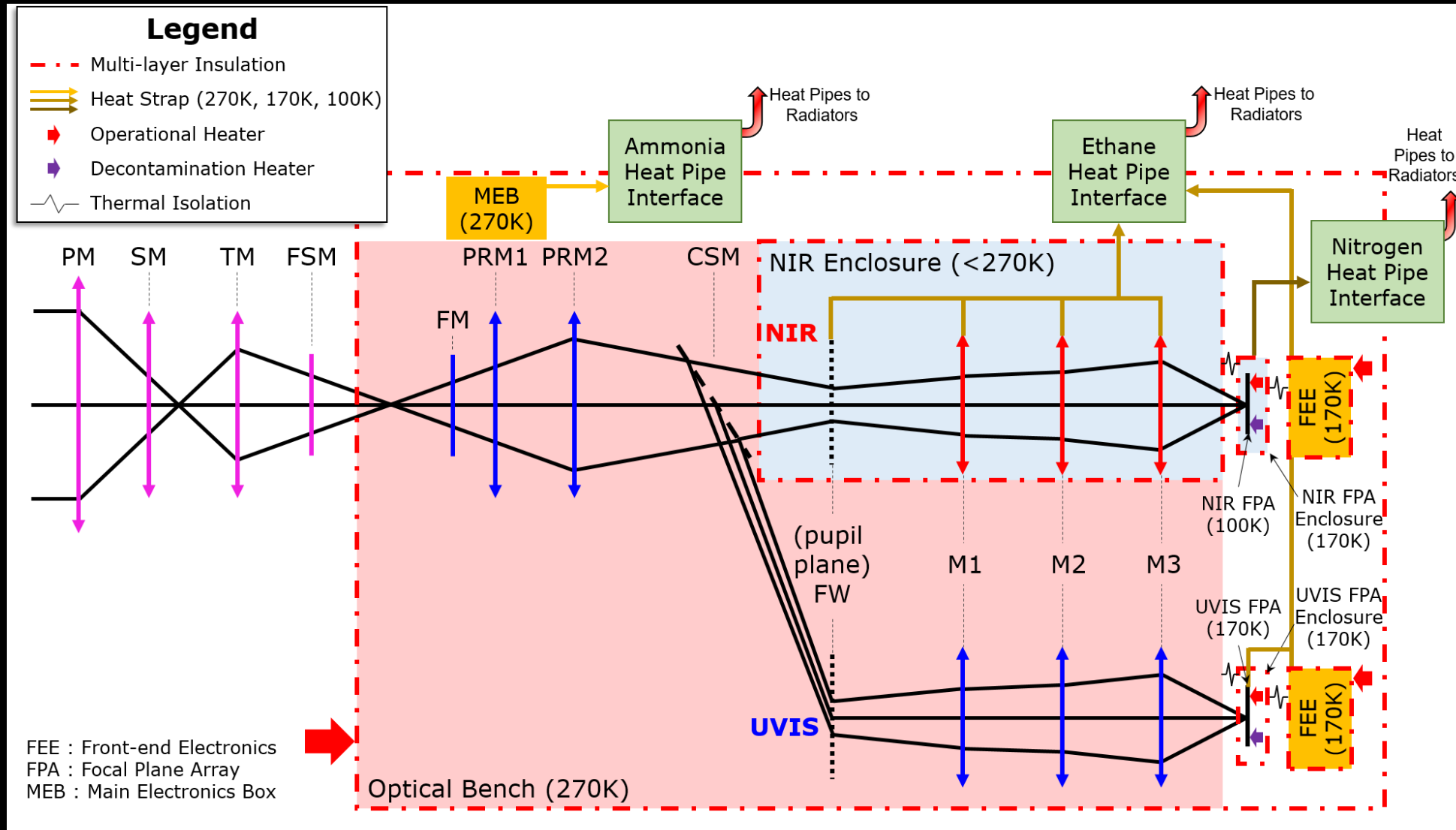

LUMOS Detailed Thermal Block Diagram

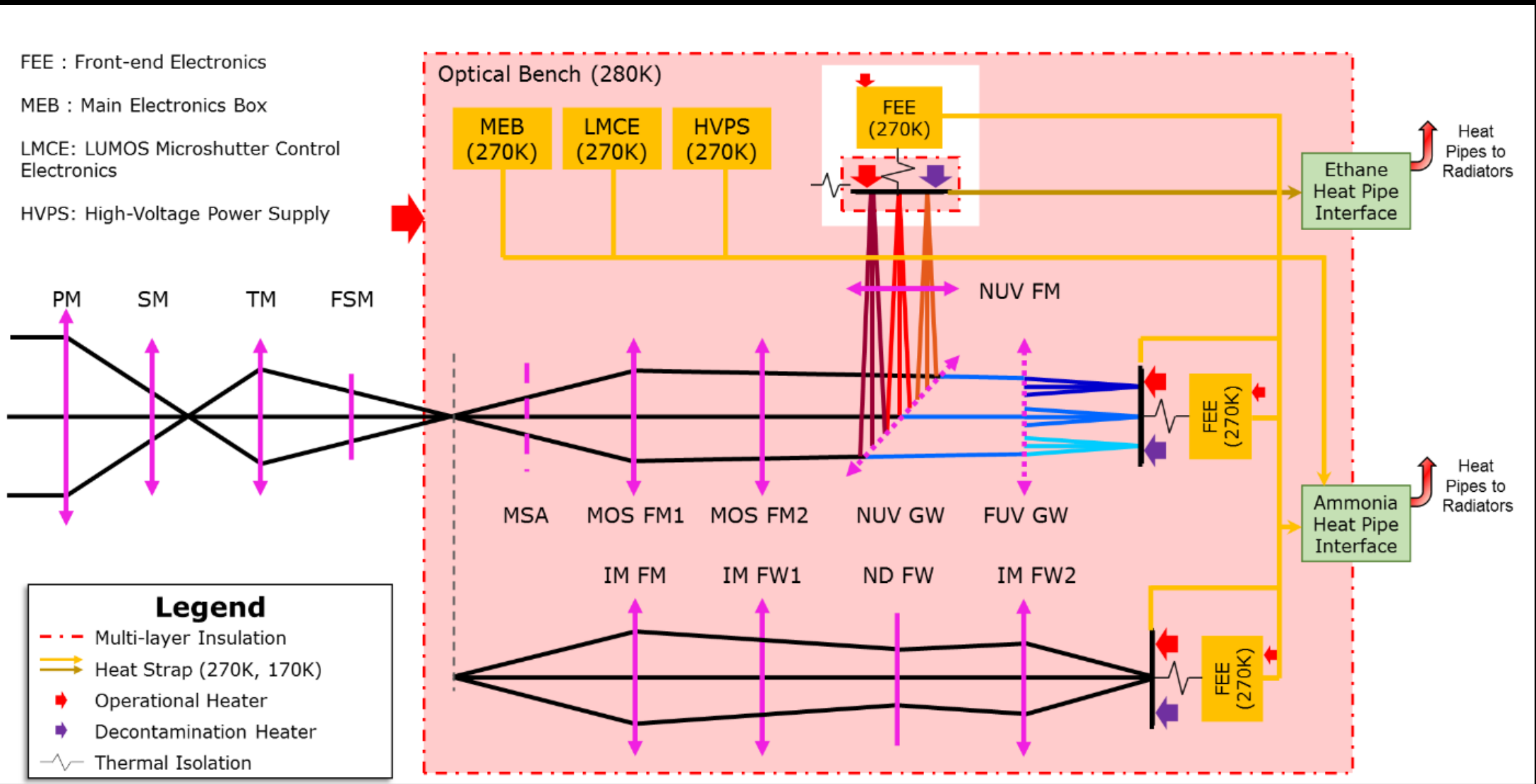
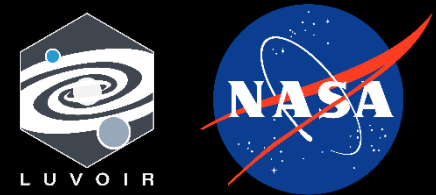

Preliminary Thermal Analysis: Heater Power



	ECLIPS-A	ECLIPS-B	LUMOS-A	LUMOS-B	HDI-A	HDI-B
Operational Heater Power for Electronics Boxes and Optical Components (W)	23.5	23.5	88.2	77.5	29.4	8.2
Operational Heater Power for Optical Benches (W)	28.4	28.4	109.0	77.0	49.3	28.2
Decontamination Heater Power (W)	6.4	6.4	76.4	61.8	56.7	22.9
Survival Heater Power (W)	58.4	58.4	331.7	221.7	112.1	44.4

- 40% uncertainty margin added for heater powers
- Relatively small optical bench heater powers considering their size, due to warm sink provided by actively heated BSF
 - LUMOS has higher heater power due to setpoint at 280 K for contamination avoidance
- For electronics boxes and optical components: heater powers estimated based on desired operational temps and to compensate for heat lost to radiators if not dissipating at max value

Preliminary Thermal Analysis: Heat to Radiator and Radiator Area



	ECLIPS -A	ECLIPS -B	LUMOS- A	LUMOS- B	HDI-A	HDI-B
Total Heat to 80 K Radiator (W)	0.3	0.3	--	--	3.2	3.1
Total Heat to 150 K Radiator (W)	14.0	14.0	36.3	11.9	68.0	48.0
Total Heat to 250 K Radiator (W)	407.4	407.4	329.3	238.9	99.9	96.0
Total 80 K Instrument Radiator Area (m²)	0.3	0.2	--	--	4.1	2.2
Total 150 K Instrument Radiator Area (m²)	0.8	1.1	2.1	0.9	4.0	3.7
Total 250 K Instrument Radiator Area (m²)	2.1	2.1	1.7	1.2	0.5	0.5

- Heat dissipation margin 50% for 170 K components, 100% for 100 K components
- BSF contains enough surface area in both concepts for fixed radiators
 - No deployables necessary

Conclusions and Recommendations



- Thermal design has been presented for instruments in both LUVOIR observatory concepts
 - Each instrument is enclosed within warm BSF
 - Three general thermal zones: 100 K, 170 K, 270-280 K
 - Series of heaters on each instrument drive components and optical benches to operational temperatures
 - Each thermal zone has its own dedicated transport heat pipes to corresponding radiators
 - LUVOIR-A requires significantly more heater power than LUVOIR-B, but power does not just scale with size of observatory
- For future development of LUVOIR:
 - Heat transport system design needs to be matured; more detailed quantification of parasitic heat leaks into heat pipes required
 - Verification of thermal design is critical to LUVOIR's success: extensive thermal analysis and test planning required to ensure instruments are being tested in flight-like condition, including considerations of heat pipe levelness and cross-talk between instruments and BSF

List of Acronyms (1)



AOS	Aft Optics System	FUV	Far Ultraviolet
BK	Black Kapton coating	FW	Filter Wheel
BSF	Backplane Support Frame	GSFC	NASA Goddard Space Flight Center
CCHP	Constant Conductance Heat Pipe	GW	Grating Wheel
CSM	Channel Select Mechanism	HDI	High Definition Imager
CTE	Coefficient of Thermal Expansion	HVPS	High-Voltage Power Source
ΔT	Change in temperature	IFS	Integral Field Spectrograph
DM	Deformable Mirror	IM	Imager Mirror
ECLIPS	Extreme Coronagraph for Living Planetary Systems	IR	Infrared
FC	Field Corrector	IS	Image Surface
FEE	Front-End Electronics	LMCE	LUMOS Microshutter Control Electronics
FM	Fold Mirror	LOWFS	Low-Order Wavefront Sensor
FPA	Focal Plane Assembly	LUMOS	LUVOIR Ultraviolet Multi-object Spectrograph
FPM	Focal Plane Mask	LUVOIR	the Large Ultraviolet/Optical/Infrared Surveyor
FSM	Fast Steering Mirror	K	Kelvin

List of Acronyms (2)



m	Meter	PMBSS	Primary Mirror Backplane Support Structure
MEB	Main Electronics Box	PR, PRM	
MLI	Multi-Layer Insulation	RM	Relay Mirror
MOS	Multi-object Spectrograph	ROSA	Roll-Out Solar Array
MSA	Micro-Shutter Array	SC	Spacecraft
NASA	National Aeronautics and Space Administration	SLI	Single-Layer Insulation
ND	Neutral Density	SM	Secondary Mirror
NIR	Near-Infrared	SMSS	Secondary Mirror Support Structure
NUV	Near-Ultraviolet	SPS	Single Planet Spectrograph
OAP	Off-Axis Parabola	TM	Tertiary Mirror
OFHC	Oxygen-Free High Conductivity copper	ULE	Ultra Low Expansion glass
OTA	Optical Telescope Assembly	UV	Ultraviolet
PAS	Payload Articulation System	UVIS	Ultraviolet /Visible
PID	Proportional-Integral-Derivative Control	VDA	Vapor-Deposited Aluminum coating
PDU	Power Distribution Unit	VIS	Visible light
PM		W	Watt(s)