

WFIRST Grism Characterization

Qian Gong, Matthew Bergkoetter, Joshua Berrier, John Chambers,
Margaret Dominguez, Wesley Fincher, John Hagopian, Cathy Marx

Characterization Overview

- The WFIRST grism design and initial prototype wavefront measurement have been presented in previous SPIE conferences and proceedings.
- This talk presents the Grism characterization that includes prototype and EDU assemblies.
- The characterization also includes spectral and radiometric calibrations.
- All measured results so far indicate that the all requirements are met.
- The measurement results have a good agreement with the designed and simulated values.
- Due to the limitation of the equipment, some tests don't have the full wavelength and field range. But when the stimulus and flight detector are ready, they will be measured over the full specified range.

Prototype Grism overview

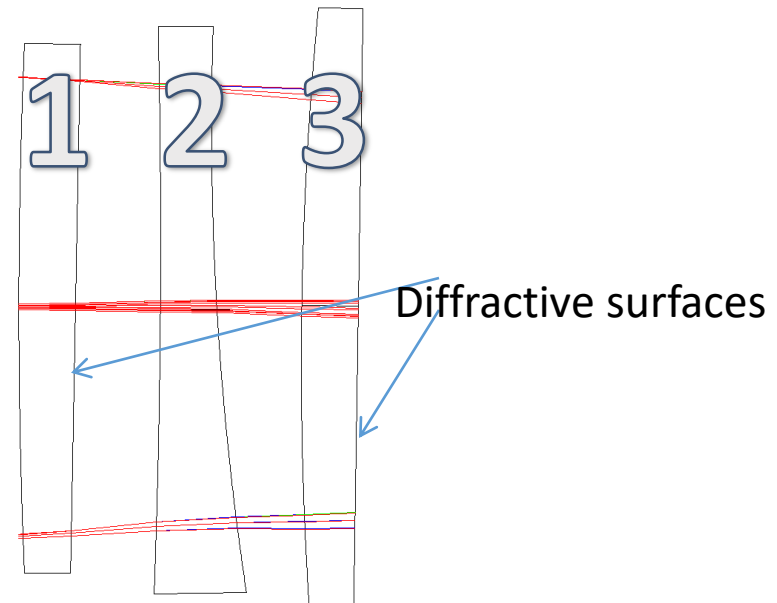
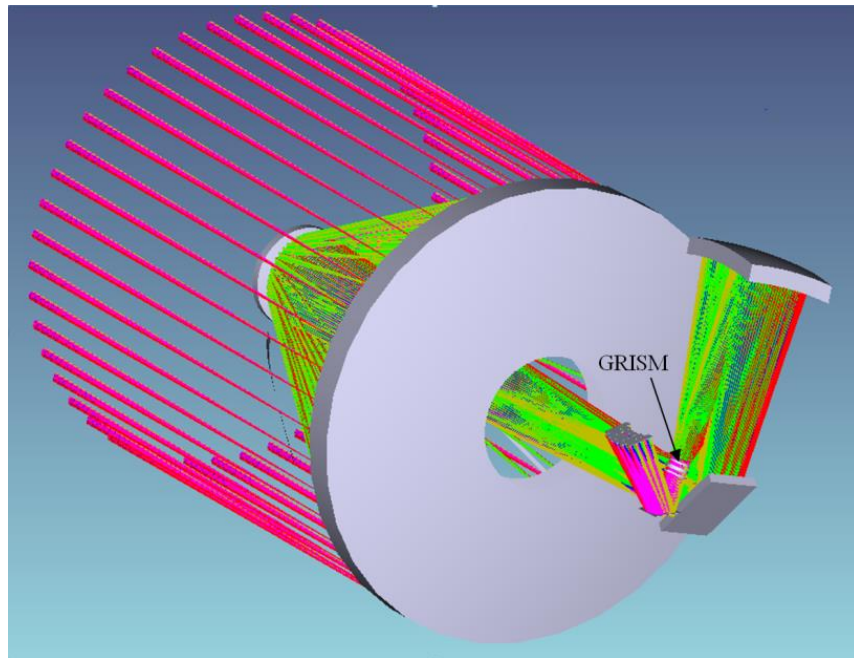

Prototype grism is a 3-element design.
The designed wavelength range is $1.35 \mu\text{m} - 1.95 \mu\text{m}$

Diffraction efficiency measurement setup

Elliptical mirror

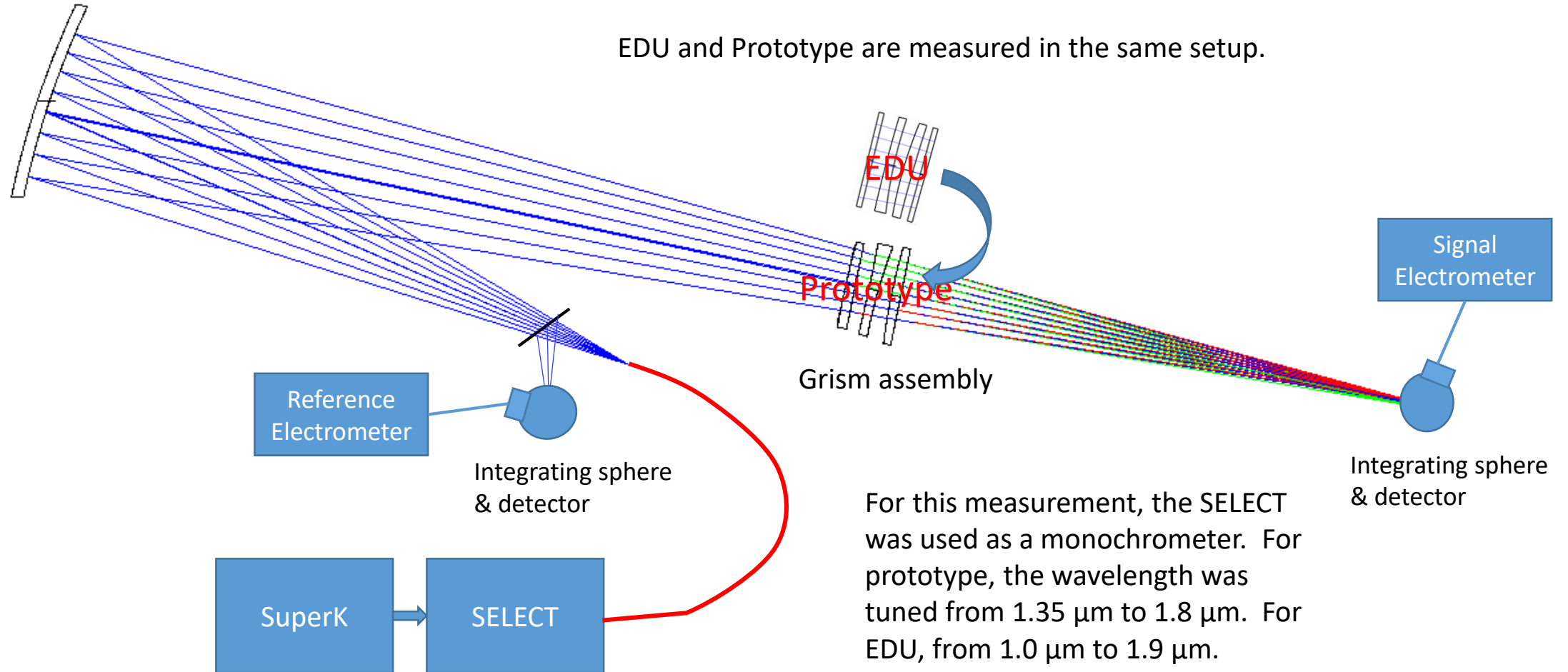

Diffraction efficiency measurement lab setup

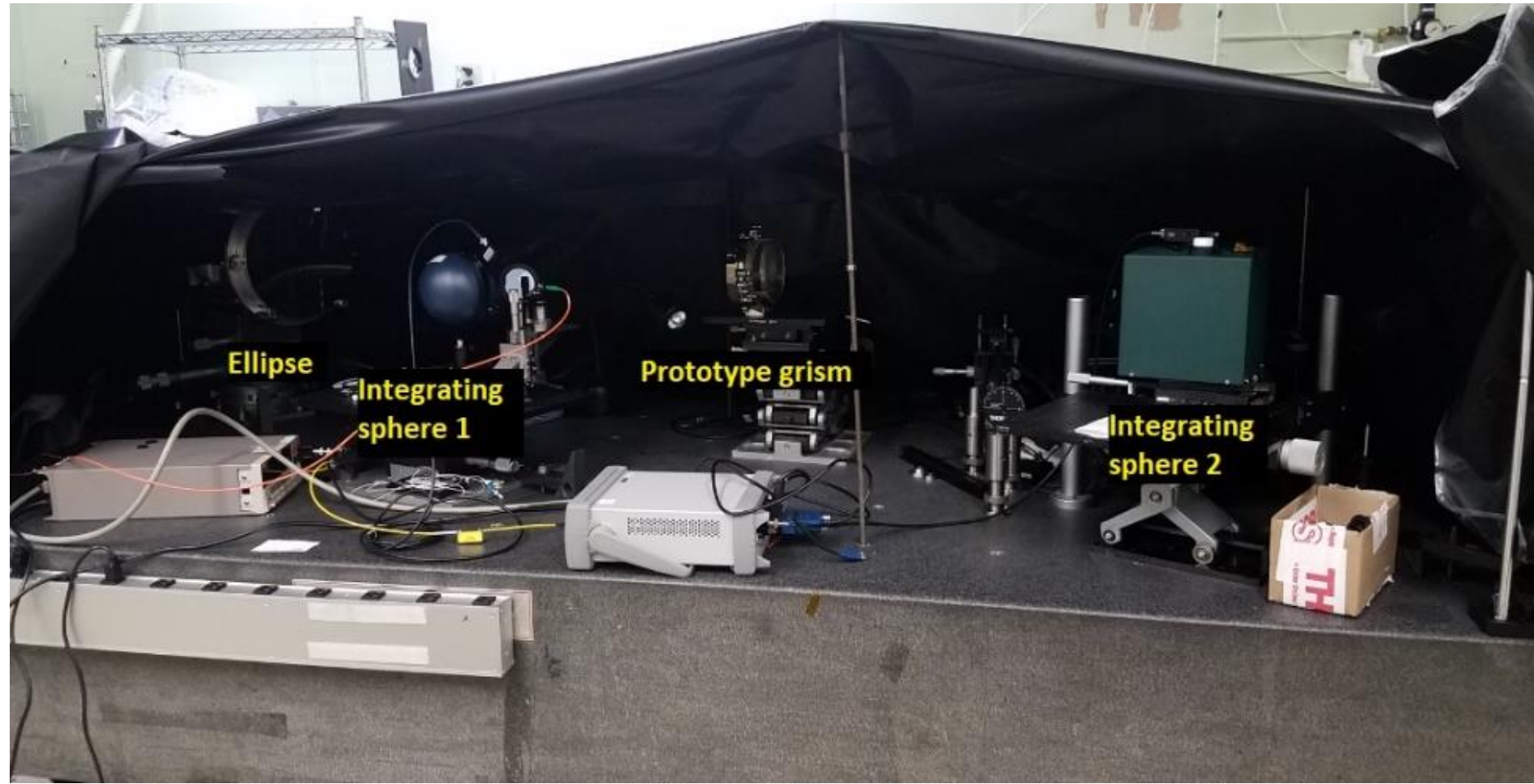

Prototype diffraction efficiency: measured and simulated

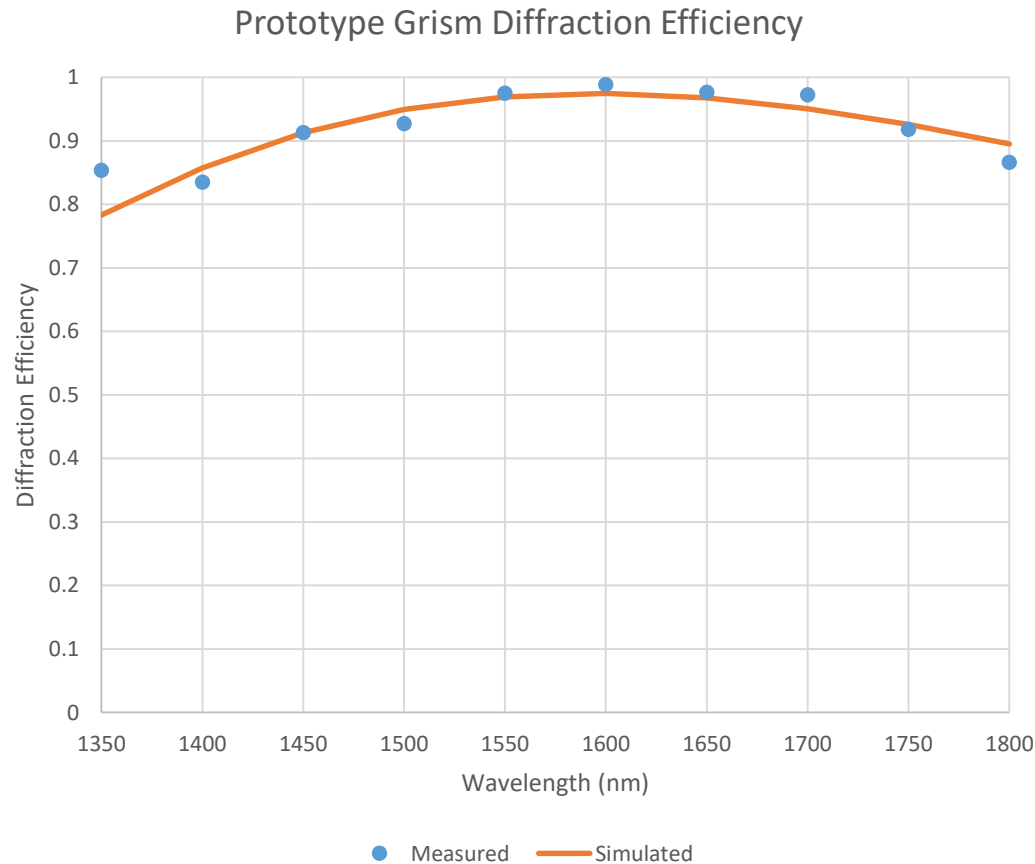

- The measured diffraction efficiency has an excellent agreement with the simulated efficiency.
- Because there are two diffractive surfaces in the grism, the simulated diffraction efficiency is the square of the single diffraction surface.
- Due to the limited detector wavelength range, the measurement only covers 1.35 μm to 1.8 μm due to detector cuts off at 1.8 μm .

Prototype conclusion: diffraction efficiency

- The measurements successfully show a high diffraction efficiency grism prototype.
- The error from theoretical curve could be the combination of fabrication error (non-uniform etch depth of diffractive patterns) and detector noise. But I believe the main contribution is the fabrication. It could also be from the etch depths from Jenoptik and RPC being a little different, which will make the peak wavelength shift.
- The measured diffraction efficiency at $1.35\ \mu\text{m}$ is about 7% higher than simulated. It seems to be higher than measurement error. We will follow up on it when performing EDU characterization.

Spectral Dispersion: Test setup

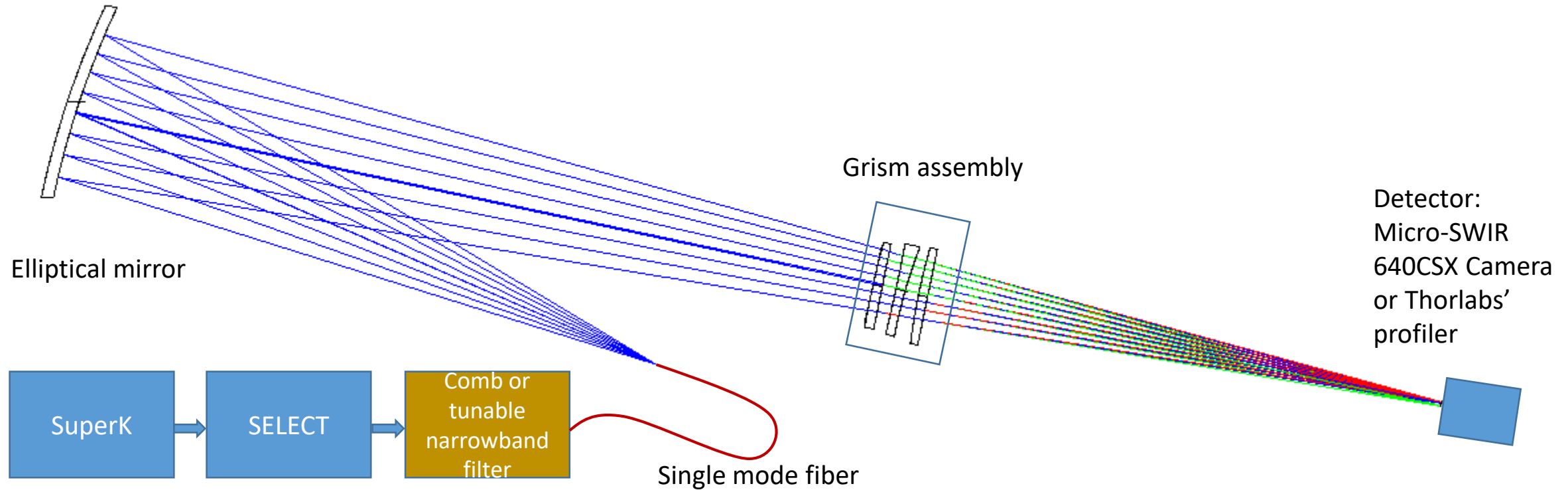

Device wavelength range (μm)						
Device	SuperK (μm)	SELECT (μm)	Comb (μm)	Narrowband		Grism
λ range	0.4 – 2.0	1.2 – 2.0	1.50 – 1.57			1.35 – 1.95

Prototype Spectral Dispersion: designed vs. measured

- 7 spectral lines are selected from SuperK + SELECT. No Comb or tunable narrow-band filter was used for this measurement.
- The selected lines were calibrated using an ANRITSU Optical Spectrum Analyzer.
- The spectrum from the central field is captured by the Sensors Unlimited Micro-SWIR 640CSX camera.
- It is noted that the spectral lines from SELECT has a bandwidth of $\sim 10\text{nm}$ FWHM. However, it does not effect the centroid, so the measurement accuracy is not compromised.

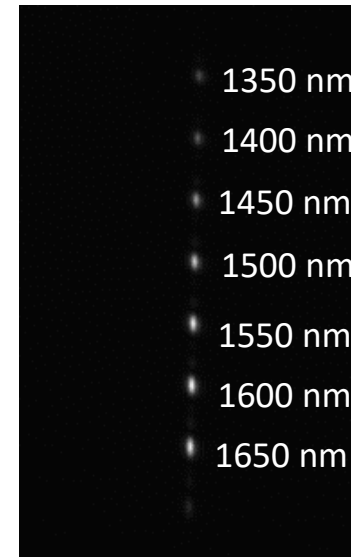
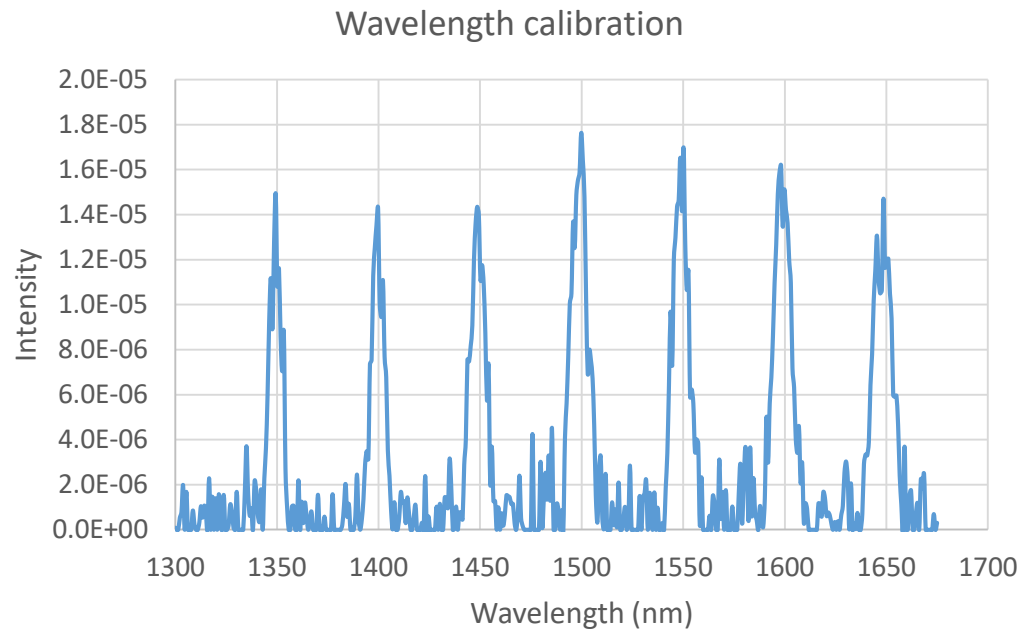

Prototype Spectral Dispersion: designed vs. measured

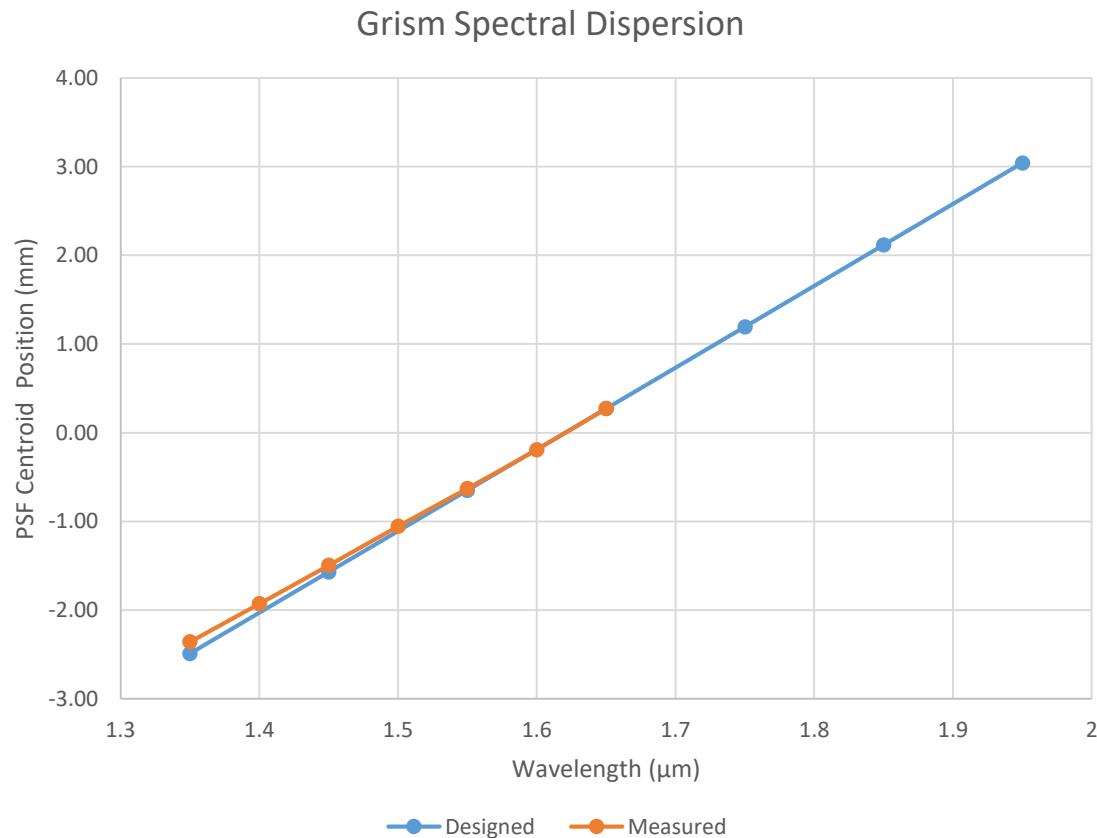

- The dispersion was measured using the calibrated wavelengths and the distances between any 2 adjacent lines from the IR camera.
- The measured dispersion is 1.14 nm /pixel, assuming the pixel size is 10 μm , which is slightly higher than 1.09 nm. However, it meets the required 1.0 – 1.2 nm / pixel.
- Possible sources for the small difference:
 - Fabrication error
 - Alignment error
 - Measurement error (less likely)

Spectral resolving power: Comb filter

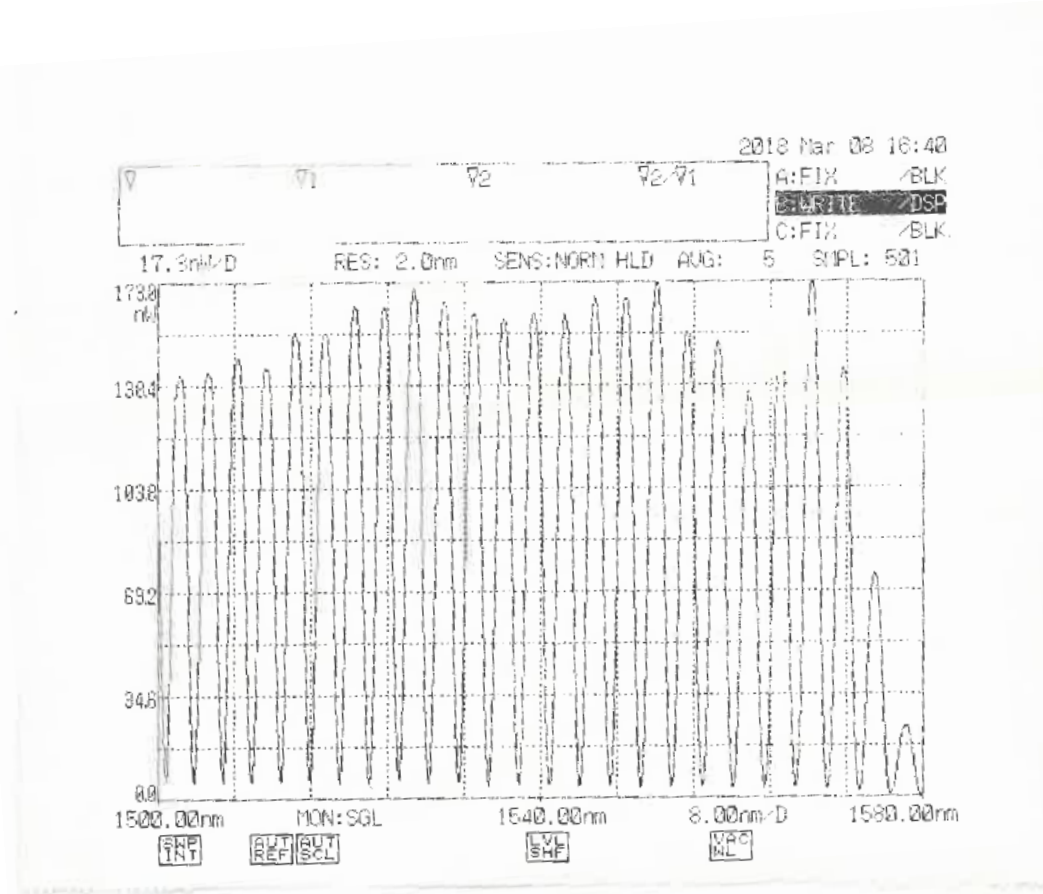

- SuperK + SELECT + Comb filter is used to provide equally spaced narrow spectral lines (3.2 nm spacing) around 1500 nm – 1570 nm. The light is directed to one of the elliptical mirror's foci by a single mode fiber as a point source.
- The spectral lines have a bandwidth (FWHM) of ~1 nm.
- A Thorlabs beam profiler was used to record the spectral profile at the focal plane after the grism.

Spectral resolving power: Comb filter (1530 – 1560 nm)

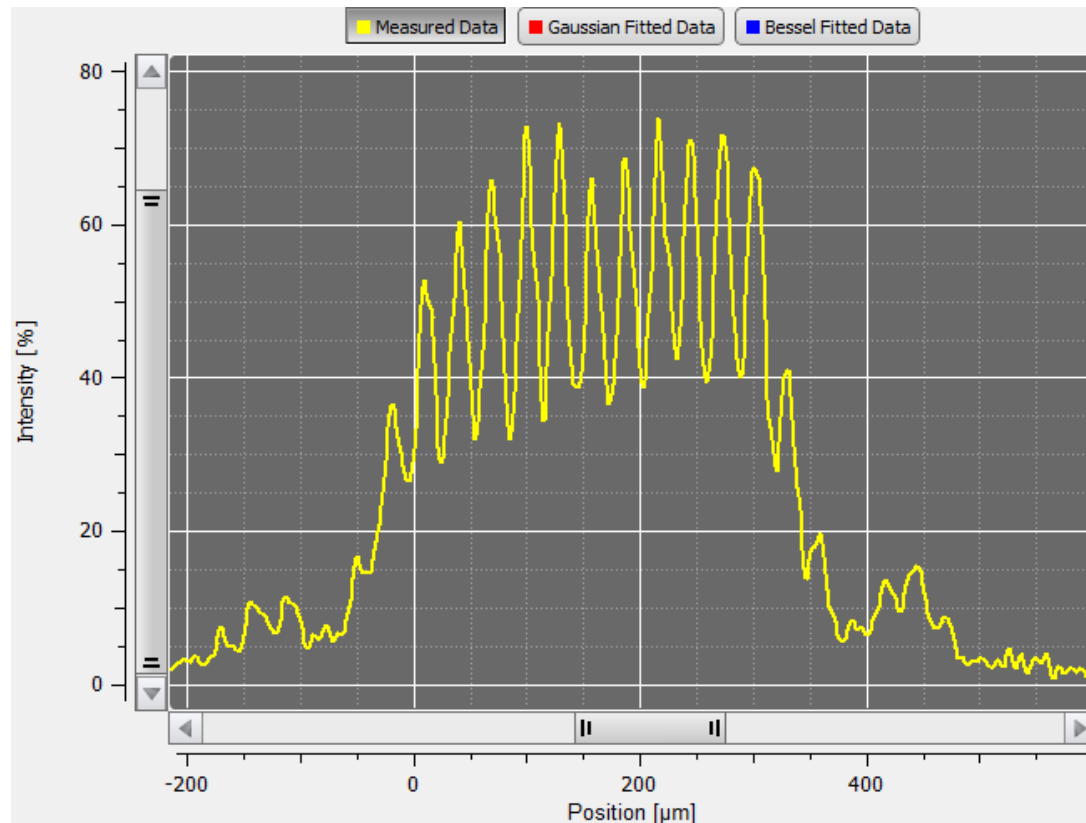

- The Spectral profile was obtained using a 5 μm slit scan profiler in the dispersion direction.
- The light source is:
SuperK + SELECT + Comb filter.
- The line spacing of the source is 3.2nm, and the line width (FWHM) is 1nm.
- It is observable that the 3.2 nm line spacing can be well resolved. If the 1nm bandwidth is de-convolved, the modulation will be much deeper.
- The required resolving power of 2.28 nm at Nyquist sampling can be achieved.

EDU Grism overview

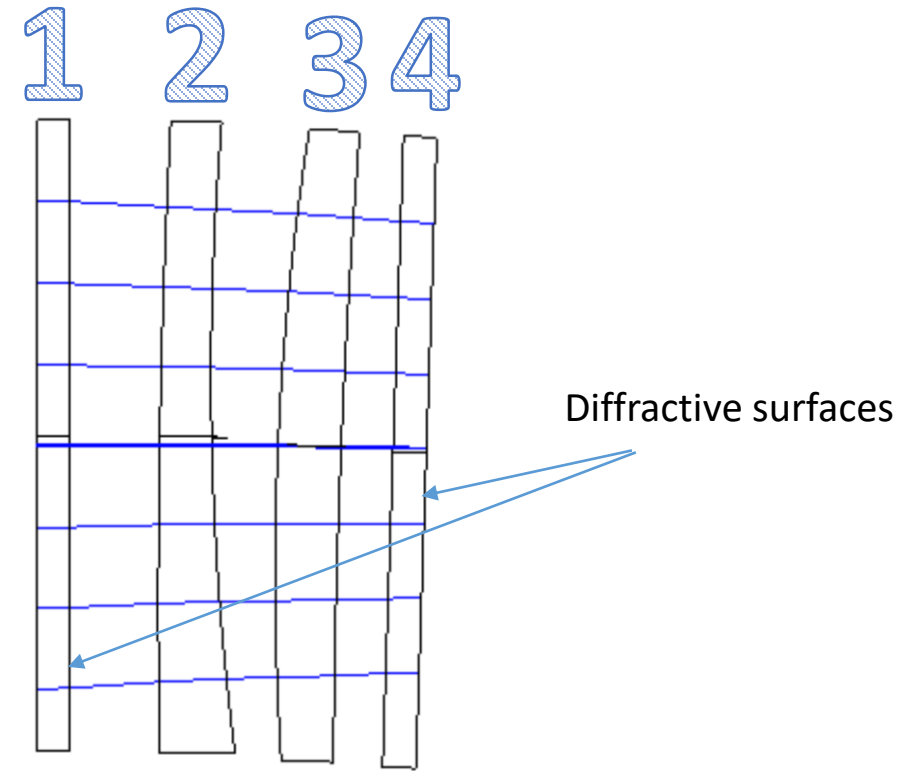
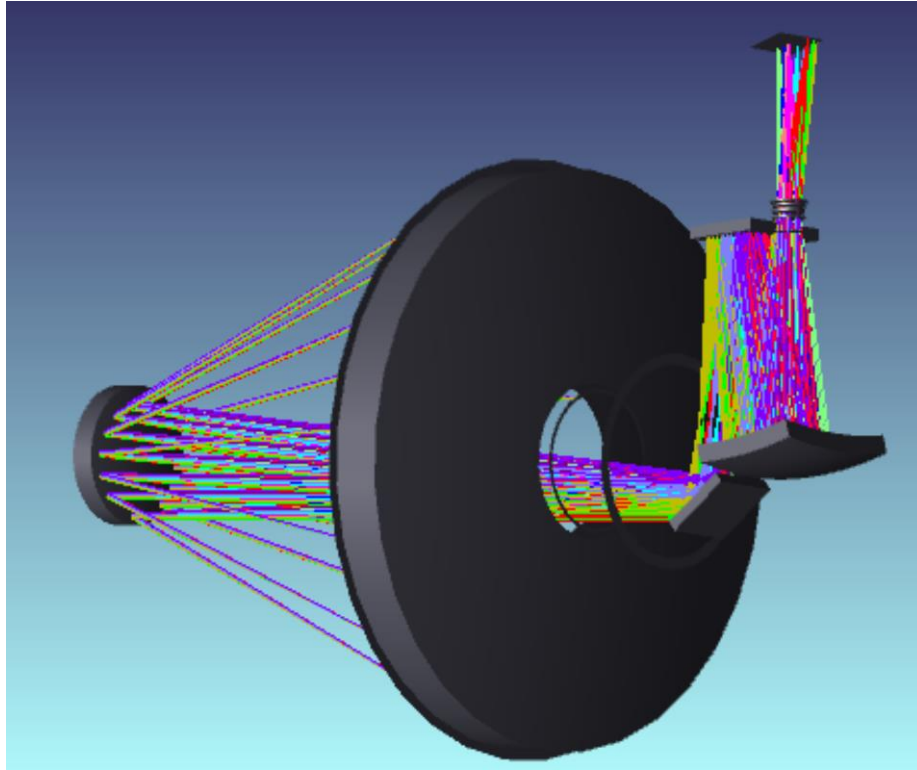

The EDU Grism is a 4-element design.
The designed wavelength range is $1.0 \mu\text{m} - 1.9 \mu\text{m}$.

EDU diffraction efficiency: Measured and simulated

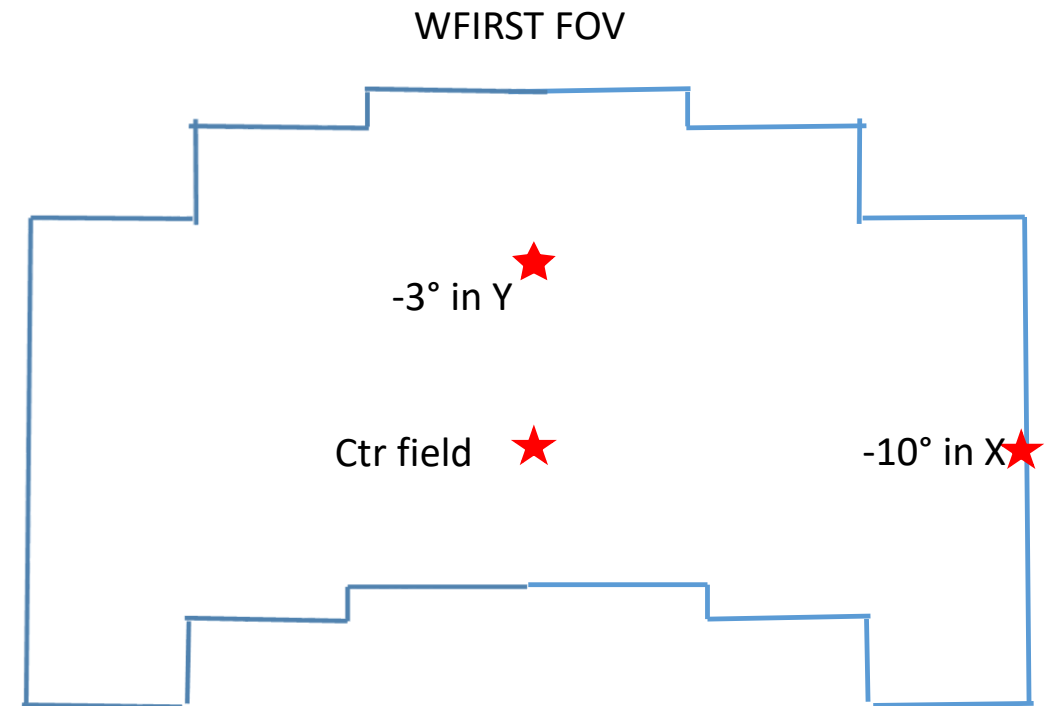
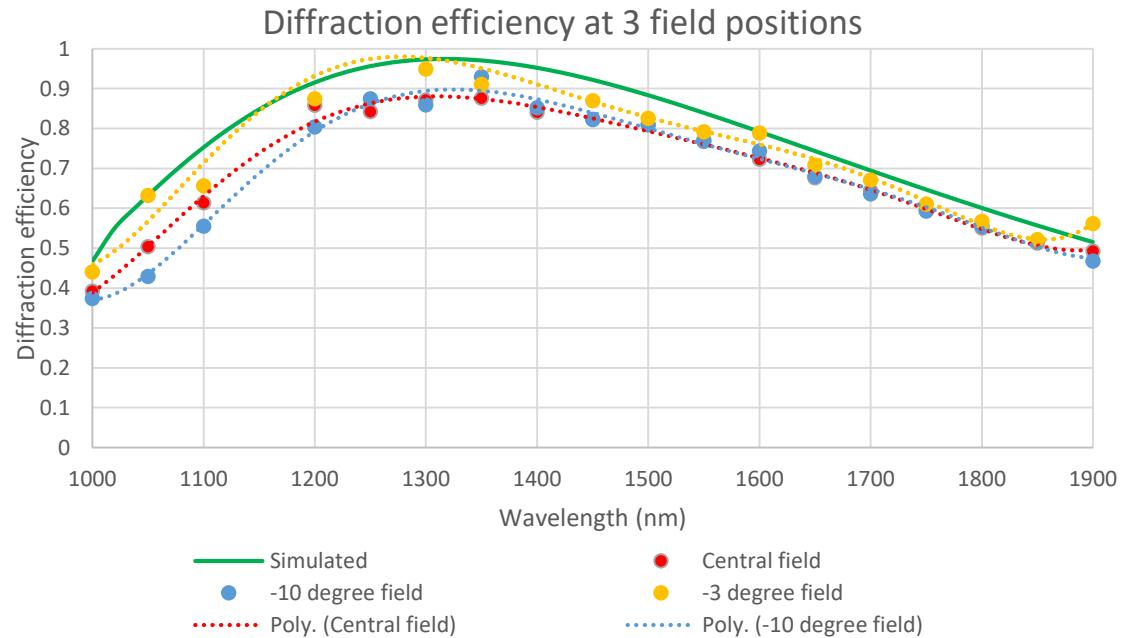

- The diffraction efficiency was measured at 3 different field positions: central, -3, and -10 degrees.
- The diffraction efficiency on the longer wavelength end has a much better match to the simulated curve. But all meet the requirement.
- The measurement covers the full wavelength range from 1.0 μm to 1.9 μm .

EDU Spectral Dispersion: designed vs. measured

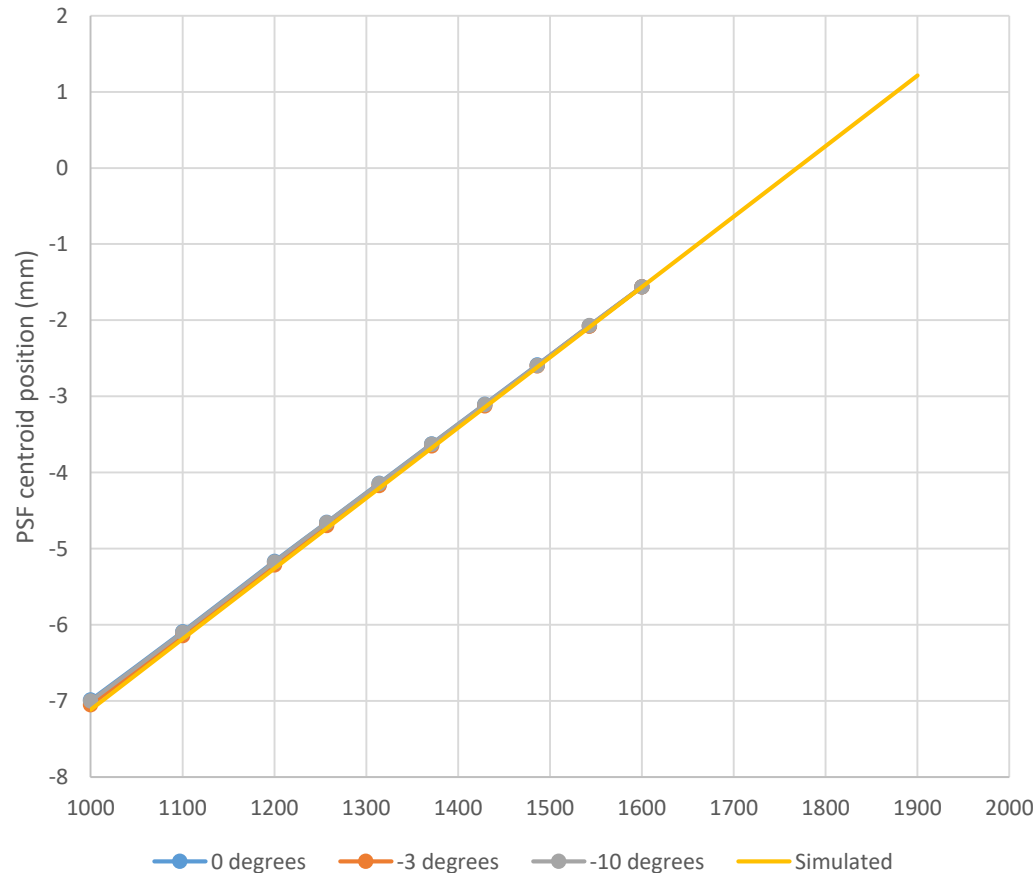

- The dispersion was measured using the calibrated wavelengths and the distances between any 2 adjacent lines from IR camera.
- Three selected positions are the same as for diffraction efficiency measurement.
 - The designed dispersion scale is 1.08 nm/pix
 - On-axis field is 1.11 nm/pix
 - -3 degree in Y is 1.095 nm/pix
 - -10 degree in X is 1.108 nm/pix
- The requirement is 1 – 1.2 nm/pix.
- The dispersion scales of all measured fields not only meet the specification, but also have an excellent match to the simulated scale.

EDU PSF from designed grating orders at 1024nm Center FOV

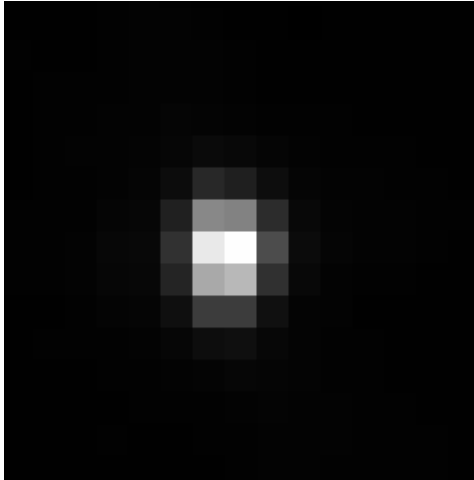

The PSF on the top is in linear scale, and at the bottom is in log scale. The spot size is very tiny, which indicates that the performance at this wavelength is about diffraction limited with this under sampled situation.

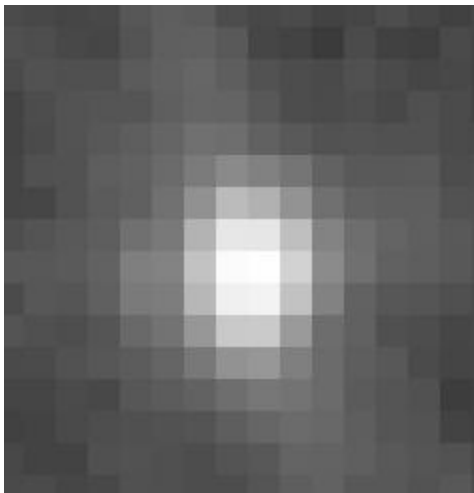

The PSF is a little longer in the vertical direction. This is because the dispersion is in the vertical direction. The spectral line width is 1 nm.

The point spread function will be magnified using a microscope objective. The magnification will be calibrated. The magnified PSF can be easily determined if it is diffraction limited. The encircled energy will be calculated from it.

Ghosts and unwanted diffraction orders

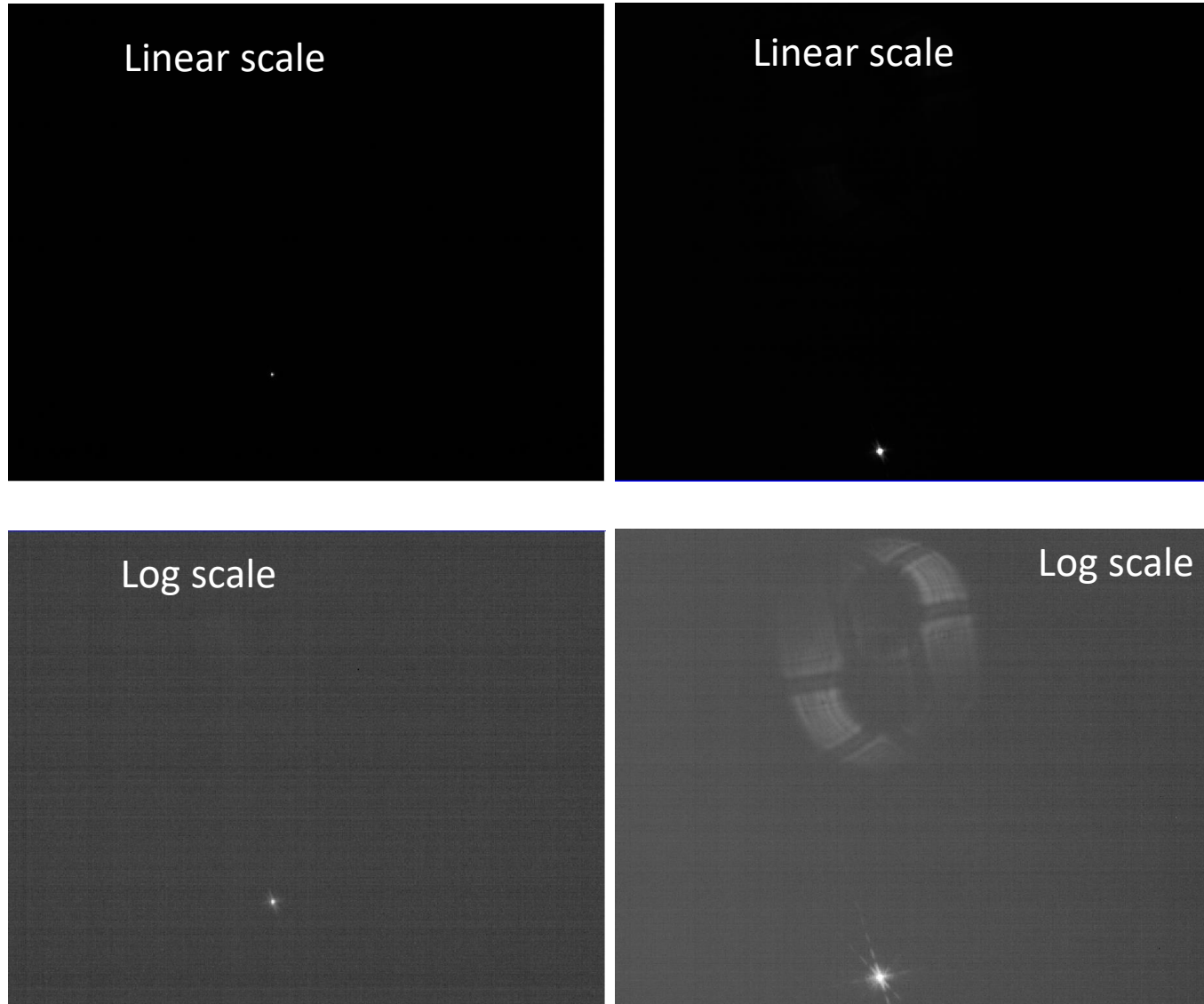

- Left images: unsaturated from the wanted order at 1024nm. The PSF peak is at ~80% of the full well. The top is on linear scale, and the bottom is on log scale. The ghost is not detectable even on log scale.
- Right images (same as left): saturated at the designed order to show the strongest unwanted order. In this case, the linear scale still does not show the ghost but the log scale does.
- The 1024nm wavelength is around the edge of the shortest wavelength range, so this is the worst case (lowest diffraction efficiency and smallest ghost size). All other wavelengths will be better, even at the long wavelength end, because the image will be scaled 2x in both x and y.
- We estimate that the object needs to be over exposed for more than 10x to see the ghost in this worst case.

Summary & Path Forward

- Prototype grism:
 - Characterization is completed. The measured and simulated diffraction efficiency have excellent agreement.
 - The dispersion is 1.14 nm / pixel, which meets the required 1 – 1.2 nm / pixel.
 - The resolving power at 1.35 μm and 1.55 μm also meets the requirement 2 – 2.4 nm / 2 pixels (derived from Nyquist of 1 – 1.2 nm / pixel).
- EDU grism:
 - Characterization is not completed yet. But all characterization so far indicates the requirements have been met.
- The next step is to complete the EDU and ETU characterizations:
 - Spectral resolving power
 - Radiometric calibration on wanted orders and ghosts
 - Power distribution versus order combination for different wavelengths
 - Provide PSFs and ghosts for data simulator

