

## A laser heterodyne radiometer for sampling plumes of icy moons

[emily.l.wilson@nasa.gov](mailto:emily.l.wilson@nasa.gov)

[geronimo.l.villanueva@nasa.gov](mailto:geronimo.l.villanueva@nasa.gov)

[matthew.l.mclinden@nasa.gov](mailto:matthew.l.mclinden@nasa.gov)

We propose to develop an instrument capable of passively sampling plumes in icy moon environments for the components needed for life and habitability. The compact, low-mass and power, orbital instrument would be an occultation-viewing laser heterodyne radiometer (LHR) that collects sunlight passing through the plumes of icy moons to measure abundancies of key trace gases such as water vapor, methane, ethane, carbon dioxide, and their isotopes.

Laser heterodyne radiometers are based on radio receiver technology and have been applied to measurements of trace gases in Earth and planetary atmospheres since the 1960s. Our team has recently adapted this technology into a 4U (20cm x 20cm x 10cm) CubeSat instrument to measure carbon dioxide, methane and water vapor in the Earth's atmosphere (launching on Virgin Orbit in 2019) and have the experience to develop this into a compact science payload to monitor gases emerging from icy moons of Saturn and Jupiter.

# A laser heterodyne radiometer for sampling plumes of icy moons

Emily Wilson, Geronimo Villanueva, Matt McLinden

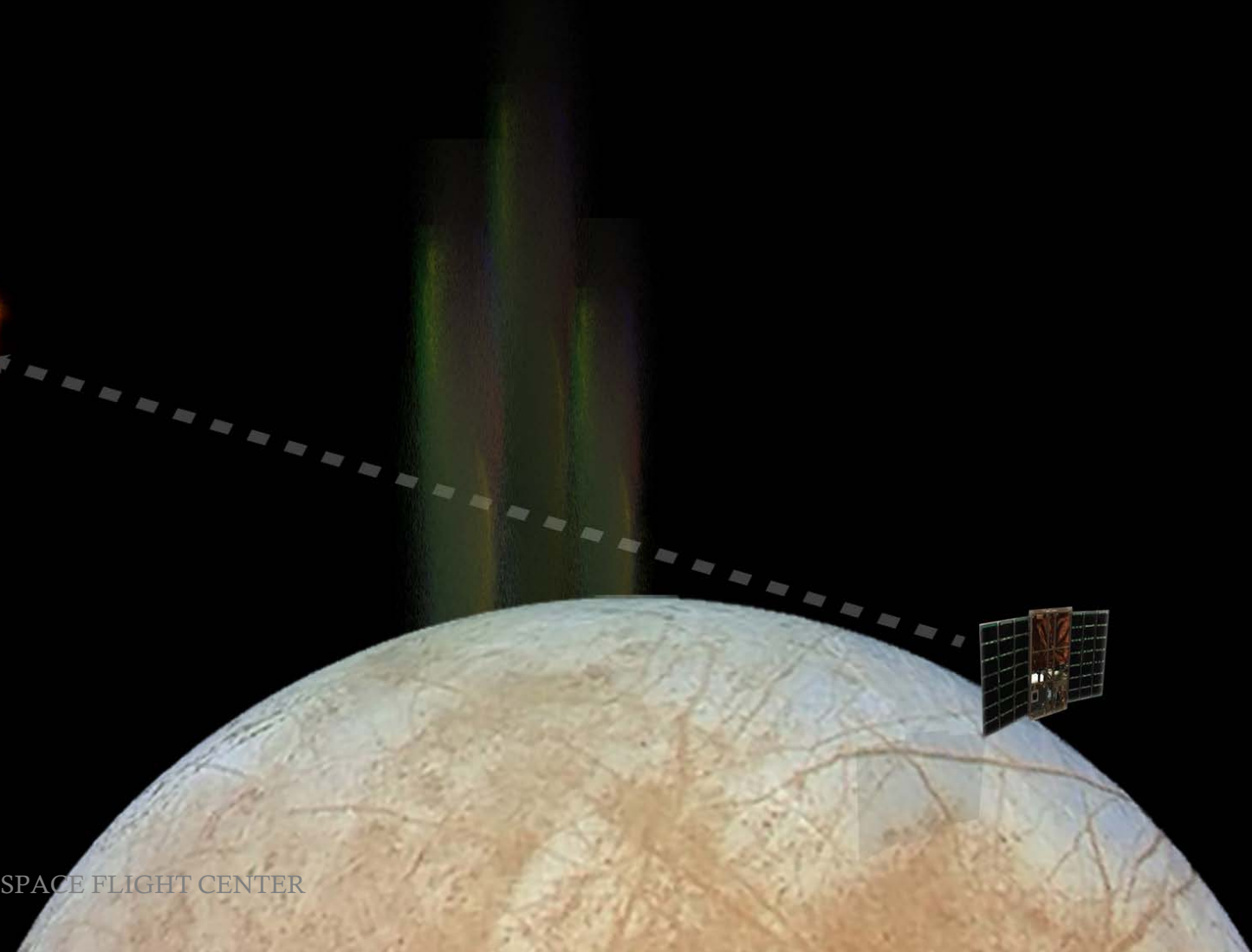

GODDARD SPACE FLIGHT CENTER



# What is a habitable environment?



Methane producing organisms have been found at the bottom of Ace lake in Antarctica in a near-freezing, saline, oxygen-free environment (*photo: Rick Cavicchioli*).

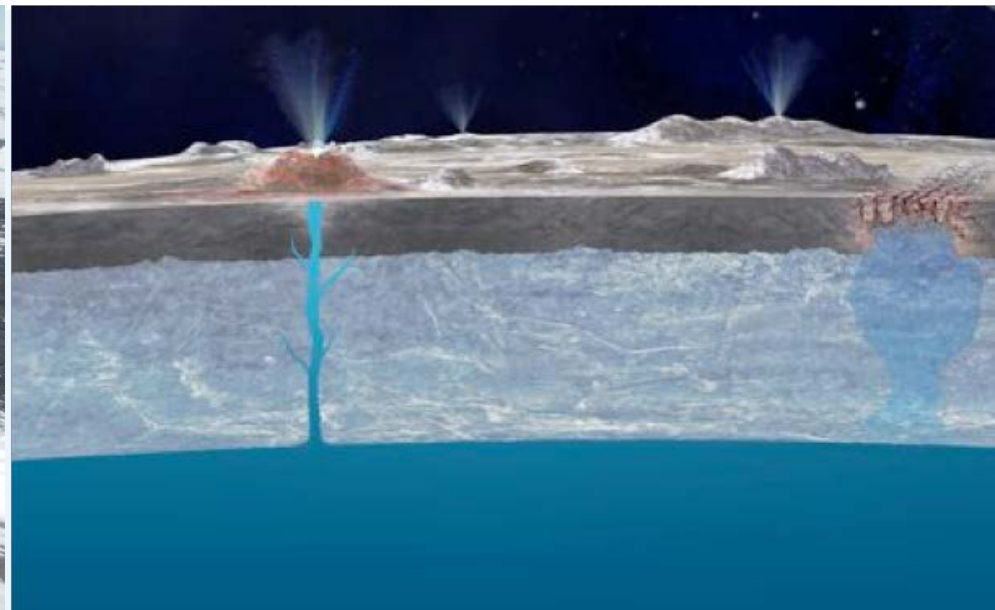

Sub-surface lakes on icy moons could also host habitable environments (*credit: Artist's concept, NASA/JPL-Caltech*).

# What lies beneath?



*What is the source of organics on Enceladus and do the underground oceans have conditions that could support life?*



*What is the source of Titan's methane and could life exist in an underground ocean?*

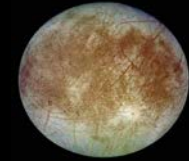

*Does Europa contain a liquid-water subsurface ocean?*

What we can measure with LHR

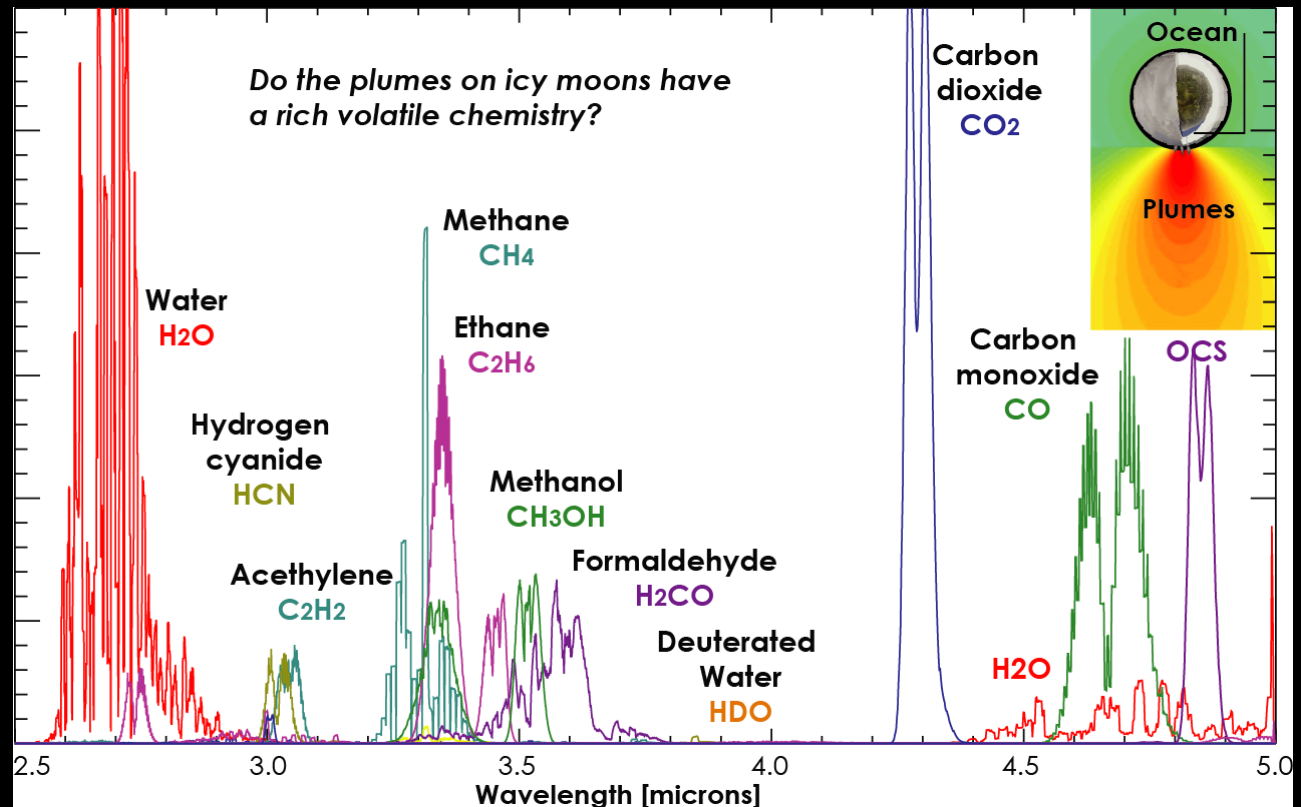



# Occultation-Viewing CubeSat

Thematically, viewing gases in plumes is similar to viewing gases in the Earth's atmosphere. Our Earth-orbiting CubeSat (Mini-Carb) is scheduled to launch via Virgin Orbit in October 2019.

Above: High-inclination orbits provide lengthy observation times when the ascending node is oriented  $90^\circ$  from the sun ( $\sim 1-4$  min observations).

Below: Goal is to view sun through the plume – orbit or fly-by works.

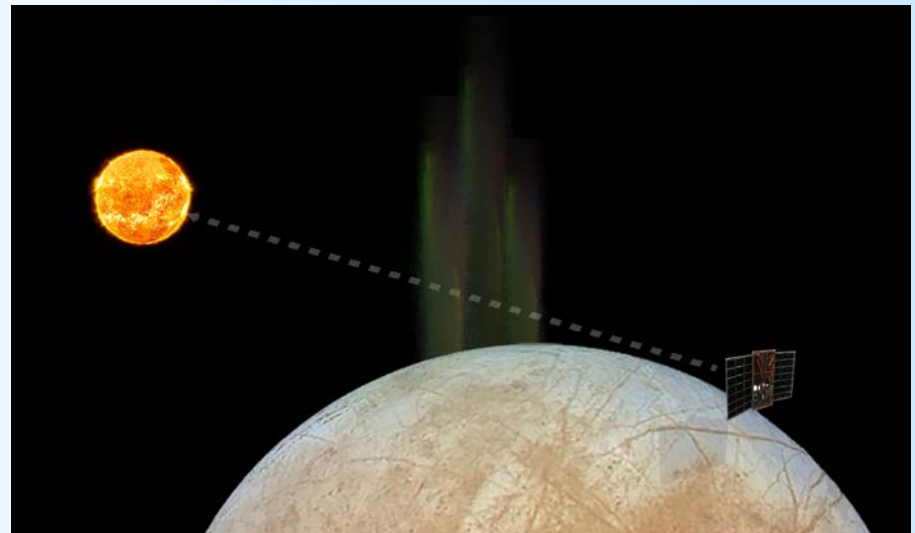
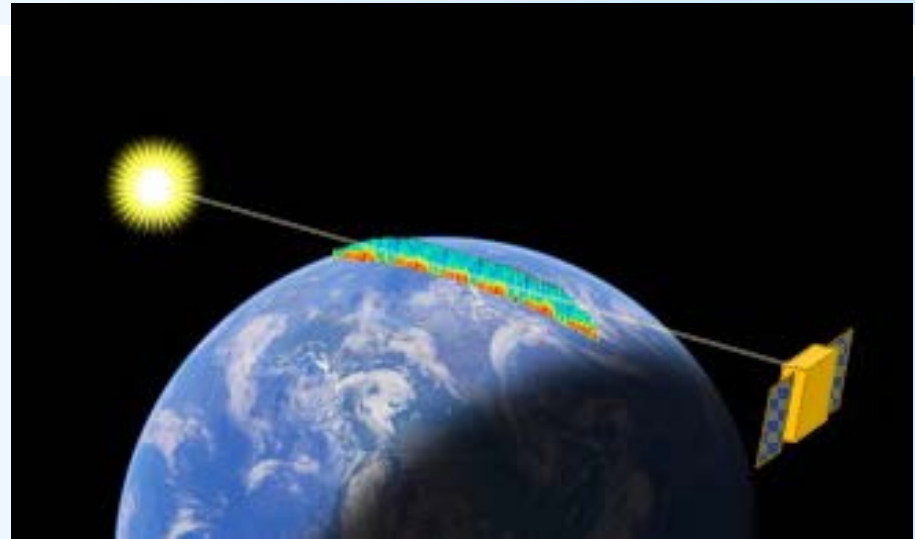





# History of Laser Heterodyne Radiometers

|   |   |
|---|---|
| <p><i>Early work</i></p>                    | <p>Menzies, R. T. &amp; Shumate, M. S. Usefulness of the infrared heterodyne radiometer in remote sensing of atmospheric pollutants. <i>Joint Conference on Sensing of Environmental Pollutants</i>, 1-4 (1971).</p>  |
| <p><i>Infrared applications</i></p>         | <p><b>Diode</b><br/>Weidmann, D. &amp; Courtois, D. Infrared 7.6-um lead-salt diode laser heterodyne radiometry of water vapor in a CH<sub>4</sub>-air premixed flat flame. <i>Applied Optics</i> <b>42</b>, 1115-1121 (2003).<br/>Ku, R. T. &amp; Spears, D. L. High-sensitivity infrared heterodyne radiometer using a tunable-diode-laser local oscillator. <i>Optics Letters</i> <b>1</b>, 84-86 (1977).</p> <p><b>Quantum cascade</b><br/>Sonnabend, G., Wirtz, D. &amp; Schieder, R. Evaluation of quantum-cascade lasers as local oscillators for infrared heterodyne spectroscopy. <i>Applied Optics</i> <b>44</b>, 7170-7172 (2005).</p>   |
| <p><i>Trace gases in the atmosphere</i></p> | <p><b>O<sub>3</sub></b><br/>Weidmann, D., Reburn, W. J. &amp; Smith, K. M. Retrieval of atmospheric ozone profiles from an infrared quantum cascade laser heterodyne radiometer: results and analysis. <i>Applied Optics</i> <b>46</b>, 7162-7171 (2007).<br/>Delahaigue, A., Courtois, D., Thiebeaux, C., Kalite, S. &amp; Parvitte, B. Atmospheric laser heterodyne detection. <i>Infrared Physics and Technology</i> <b>37</b>, 7-12 (1996).</p> <p><b>H<sub>2</sub>O &amp; CH<sub>4</sub></b><br/>Seals Jr., R. K. Analysis of Tunable Laser Heterodyne Radiometry: Remote Sensing of Atmospheric Gases. <i>AIAA Journal</i> <b>12</b>, 1118-1122 (1974).</p> <p><b>NH<sub>3</sub></b><br/>Zeninari, V., Parvitte, B., Courtois, D., Delahaigue, A. &amp; Thiebeaux, C. An instrument for atmospheric detection of NH<sub>3</sub> by laser heterodyne radiometry. <i>J. Quant. Spectros. Radiat. Transfer</i> <b>59</b>, 353-359 (1998).</p> <p><b>ClO</b><br/>Menzies, R. T. A Re-Evaluation of Laser Heterodyne Radiometer ClO Measurements. <i>Geophysical Research Letters</i> <b>10</b>, 729-732 (1983).</p> |
| <p><i>Work at GSFC</i></p>                  | <p>Abbas, M. M., Mumma, M. J., Kostiuik, T. &amp; Buhl, D. Sensitivity limits of an infrared heterodyne spectrometer for astrophysical applications. <i>Applied Optics</i> <b>15</b>, 427-436 (1976).<br/>Kostiuik, T. &amp; Mumma, M. J. Remote sensing by IR heterodyne spectroscopy. <i>Applied Optics</i> <b>22</b>, 2644-2654 (1983).<br/>Livengood, T. A. et al. High-resolution infrared spectroscopy of ethane in Titan's stratosphere in the Huygens epoch. <i>Journal of Geophysical Research</i> <b>111</b>, 1-10 (2006).</p>  |





# How it works

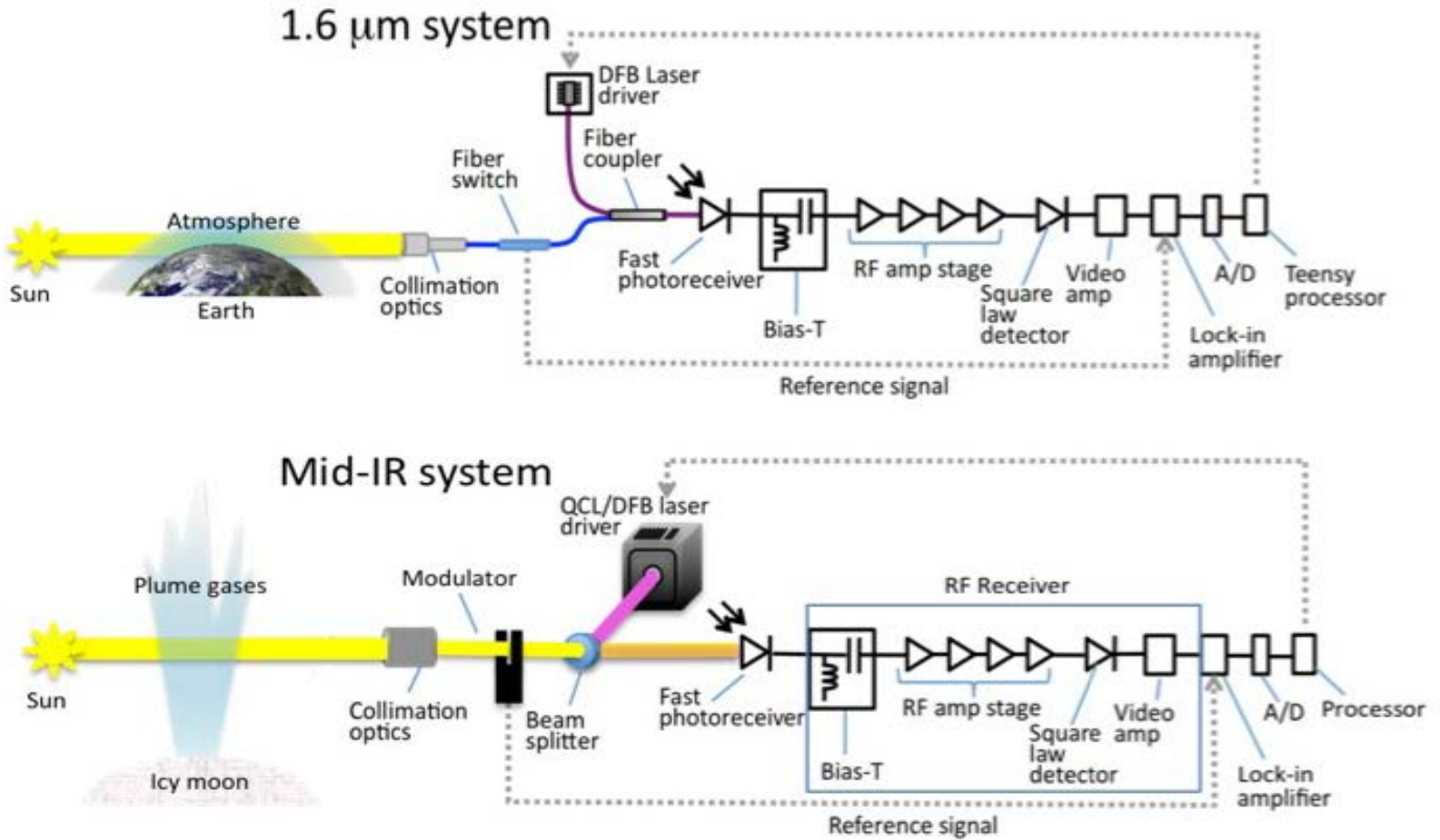



## Our past efforts

Ground LHR instrument observing  $\text{CO}_2$  and  $\text{CH}_4$  in atmospheric column over thawing permafrost in Alaska.

Testing LHR as part of Hi-SEAS (Hawai'i Space Exploration Analog and Simulation): LHR as ground instrument for monitoring atmospheric conditions on a planetary mission.

CubeSat LHR (Mini-Carb) after integration. Occultation-viewing. Will monitor  $\text{CO}_2$ ,  $\text{CH}_4$ , and  $\text{H}_2\text{O}$  in limb from LEO.

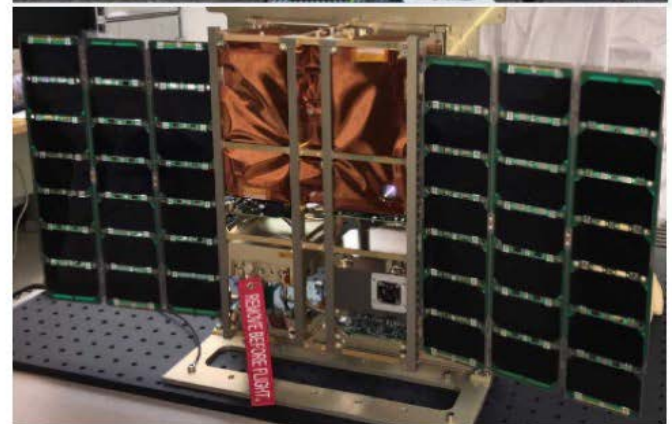
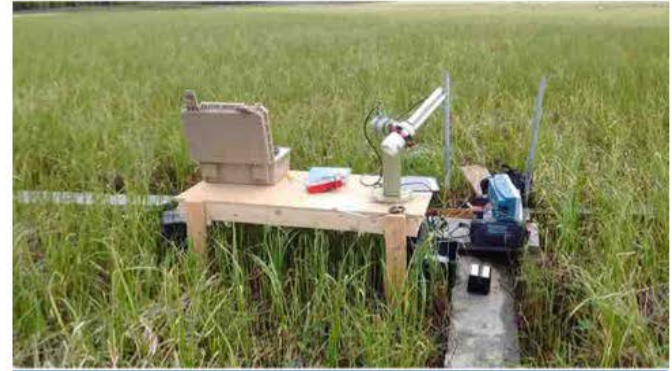





# Sample data – both CH<sub>4</sub> and CO<sub>2</sub> with single laser

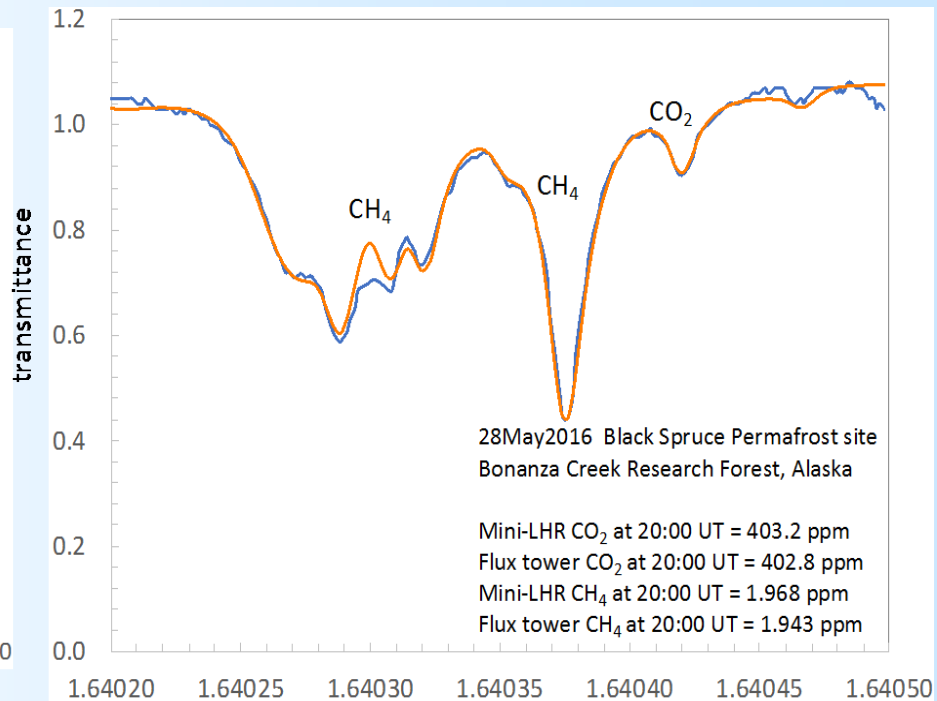
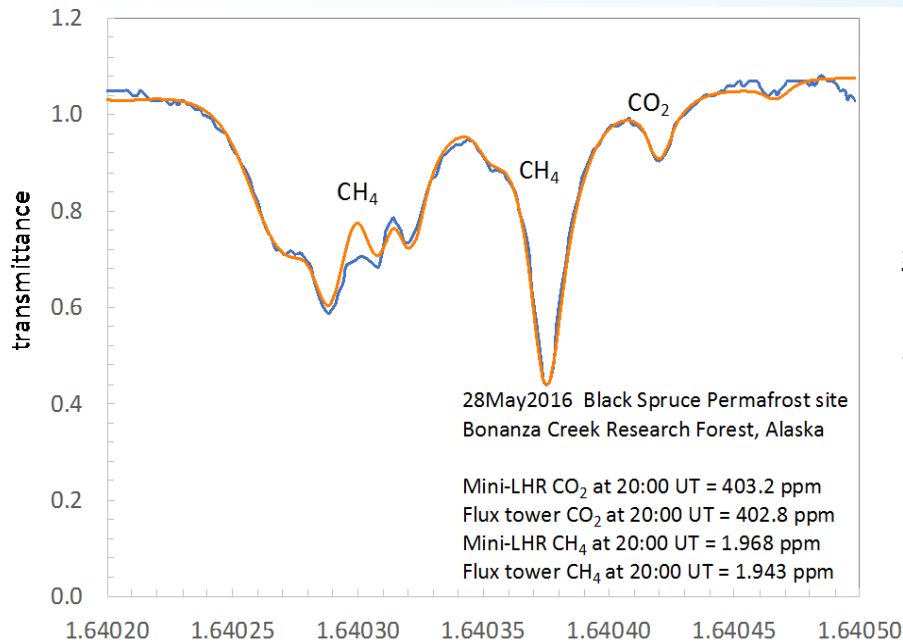



# Analysis using Planetary Spectrum Generator (PSG) based Algorithm

## Simulating Spectra with PSG

- PSG (<https://ssed.gsfc.nasa.gov/psg>) developed at NASA/GSFC – PI: Geronimo Villanueva
- Combines several state-of-the-art radiative transfer models, spectroscopic databases and planetary database
- Includes meteorological data from MERRA (Modern Era Retrospective-Analysis for Research and Applications)
- Includes refraction of sunlight through atmosphere
- Includes computationally efficient scattering package

## Fitting Simulation to Data

- Code generates an initial configuration file with geometry parameters (airmass, phase angle, etc.) and an *a priori* vertical profile based on date and location
- Fitting routine perturbs each of the abundances using Levenberg-Marquardt algorithm (an iterative least-squares curve fitting procedure).



# Planned CubeSat Spectral Region

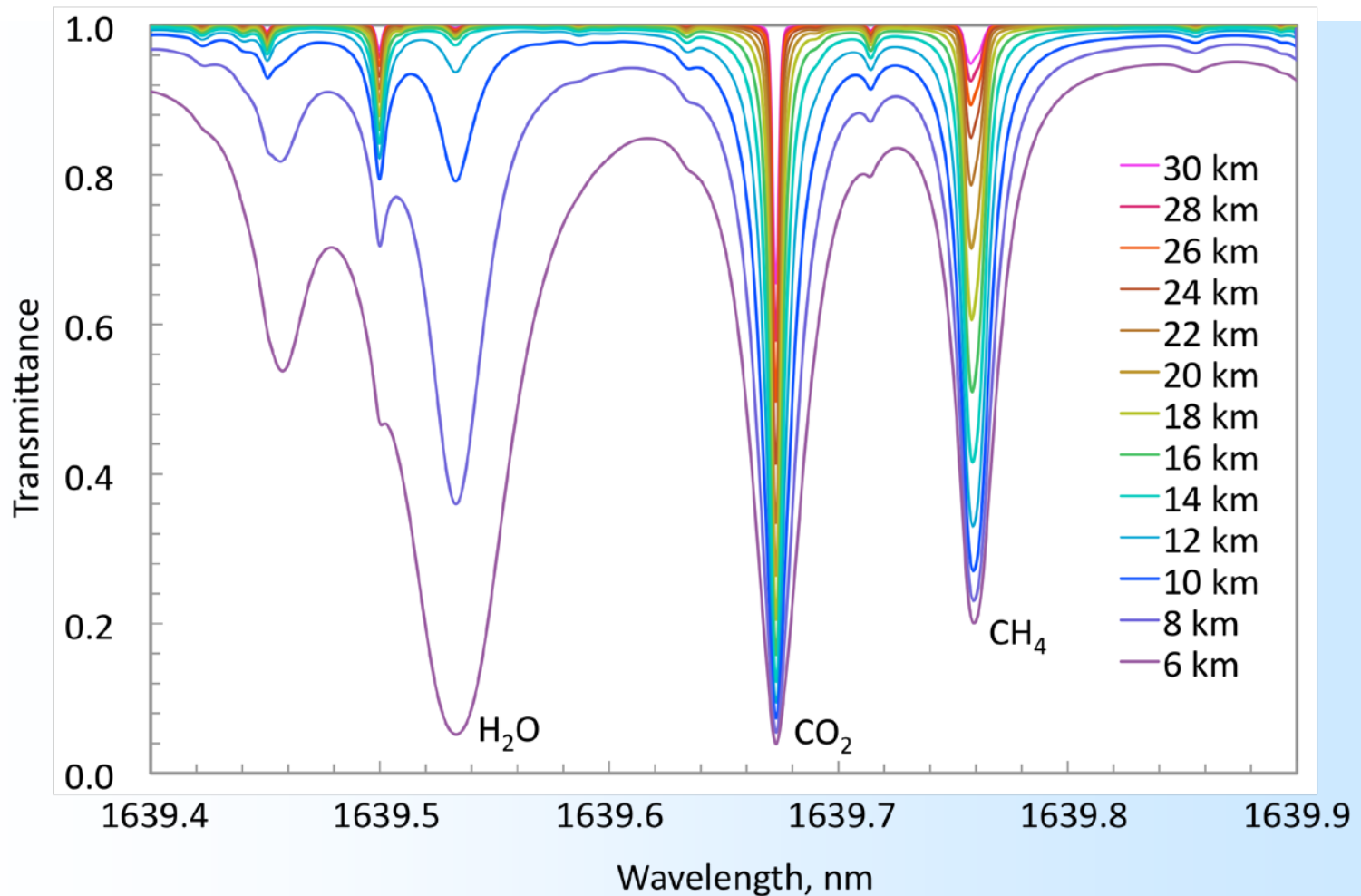



# CubeSat Integration at LLNL



Photo Credit: Dan Linehan/LLNL



## Recent Publications

Palmer, P. I., Wilson, E. L., Villanueva, G. L., Liuzzi, G., Feng, L., DiGregorio, A. J., Mao, J., Ott, L., Duncan, B. Potential improvements in global carbon flux estimates from a network of laser heterodyne radiometer measurements of column carbon dioxide. *Atmos. Meas. Tech.* 12, 2579-2594 (2019).

Wilson, E. L., DiGregorio, A. J., Riot, V. J., Ammons, M. S., Bruner, W. W., Carter, D., Mao, J. –P, Ramanathan, A., Strahan, S. E., Oman, L. D., Hoffman, C., Garner, R. M. A 4U laser heterodyne radiometer for methane (CH<sub>4</sub>) and carbon dioxide (CO<sub>2</sub>) measurements from an occultation-viewing CubeSat. *Meas. Sci. Technol.* 28, 035902, doi:10.1088/1361-6501/aa5440 (2017).

Melroy, H. R., Wilson, E. L., Clarke, G. B., Ott, L. E., Mao, J., Ramanathan, A. K., McLinden, M. L. Autonomous field measurements of CO<sub>2</sub> in the atmospheric column with the miniaturized laser heterodyne radiometer (Mini-LHR). *Applied Physics B: Lasers & Optics*, DOI 10.1007/s00340-015-6172-3 (2015).

Wilson, E. L. et al. Miniaturized Laser Heterodyne Radiometer for Measurements of CO<sub>2</sub> in the Atmospheric Column. *Applied Physics B: Lasers & Optics* 114, 385-393, doi:10.1007/s00340-013-5531-1 (2014).

Clarke, G. B., Wilson, E. L., Miller, J. H. & Melroy, H. R. Uncertainty analysis for the miniaturized laser heterodyne radiometer (mini-LHR). *Measurement Science and Technology* 25, 055204-055209 (2014).





# Acknowledgements

This effort was funded by the NASA Interdisciplinary Science Program (HQ Manager: Jared Entin), GSFC Internal Funds including IRAD, SIF, Start-up, Operating & Technical Equipment funds

We would like to thank:

NASA IDS, GSFC IRAD, and SIF Programs

Brent Holben and the AERONET Team

Jake Bleacher and Hi-SEAS team

Paul Palmer/University of Edinburgh

Bill Bruner & Vincent Riot/Lawrence Livermore National Laboratory