



Aerodynamic and Aerothermal Simulations of Mars Concept Vehicles using Overset *DPLR*

Chun Tang, NASA Ames

Presented By Chun Tang

TFAWS
LaRC 2019

Thermal & Fluids Analysis Workshop
TFAWS 2019
August 26-30, 2019
NASA Langley Research Center
Hampton, VA



Outline



- Overview of Descent Systems Studies (DSS) Program
 - Concept vehicles for landing heavy payloads to Mars
- Grid generation for Data Parallel Line Relaxation (*DPLR*)
 - Point-matched volume grids
 - Oversetting grids framework
 - Overset approach for *DPLR*
- Overset *DPLR* results
 - *DPLR* solutions on a Mid-L/D configuration at various freestream conditions and body flap deflections
- Concluding remarks
- Future work

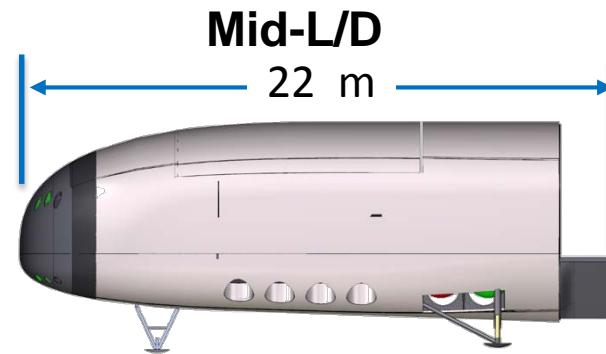

- A Low-L/D and a Mid-L/D vehicles are being evaluated for landing heavy payloads to the surface of Mars
- For the Mid-L/D configuration, we would like to anchor high-fidelity Computational Fluid Dynamics (CFD) solutions to the current aerodynamic and aerothermal databases
- *DPLR* (a structured, finite-volume, Navier-Stokes code with finite-rate chemistry) is used at Ames to run these CFD simulations

- First step in any CFD simulation is grid generation
 - Grid generation on a complex configuration can often be a bottleneck in running a large number of cases. For hypersonic simulations, grids need to be aligned to the bow shock and sufficient resolution of the boundary layer is necessary for accurate surface heat flux estimates
- Hyperbolic grid generation on a simple geometry
 - Simple grid topology: single layer of grid points from the vehicle's surface to the outer boundary
 - “Beach ball” grid can accommodate any combination of angle-of-attack and sideslip
 - Build-in grid alignment and wall clustering tools in *DPLR* make grid alignments easy for the user. Process has been automated to run a large number of database cases (Orion MPCV)

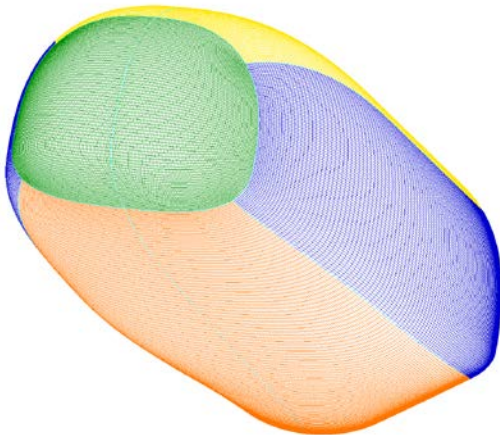

Point-matched surface grids

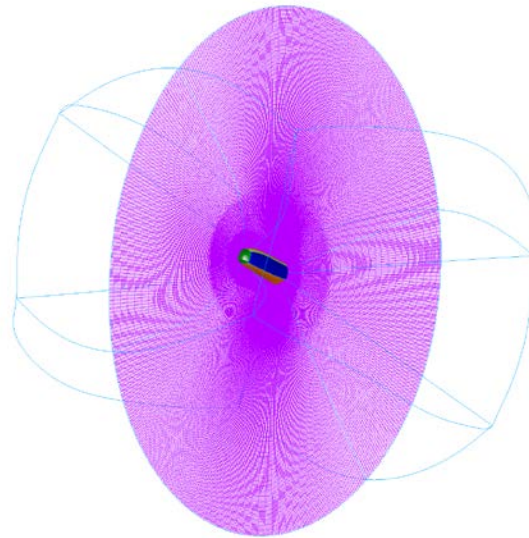

Initial volume grid

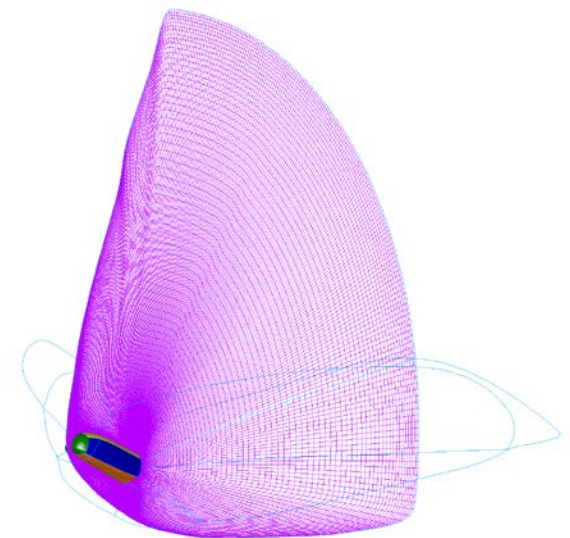

Adapted volume grid

- Hyperbolic grid generation for point-matched meshes can fail for certain geometries
- Alternative mesh generation techniques
 - Algebraic methods
 - Elliptical grid generation
 - **Oversetting grids**

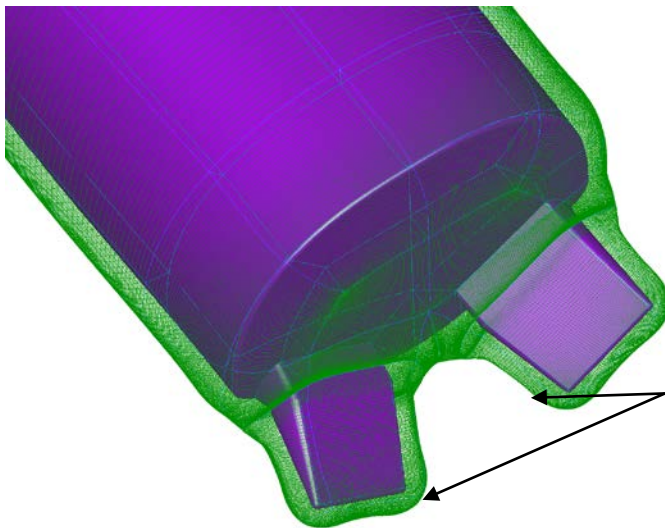

Mid-L/D configuration with body flaps

Grid points will collide and produce negative areas/volumes

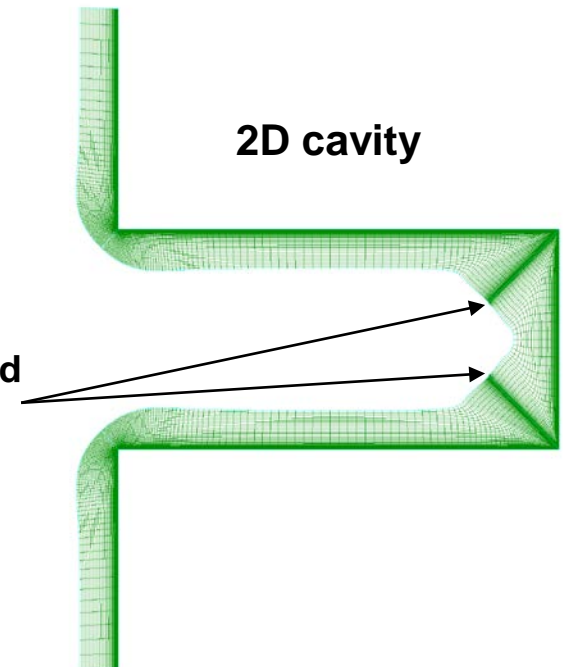

2D cavity

- Overset grids developed to handle complex geometries (for example, Overflow at NASA, Overture at LLNL)
 - Basic concept is to use overlapping structured grids to define the geometry and the computational domain
 - While this framework is efficient and powerful, new users may find it difficult to implement the hole-cutting and grid connectivity process

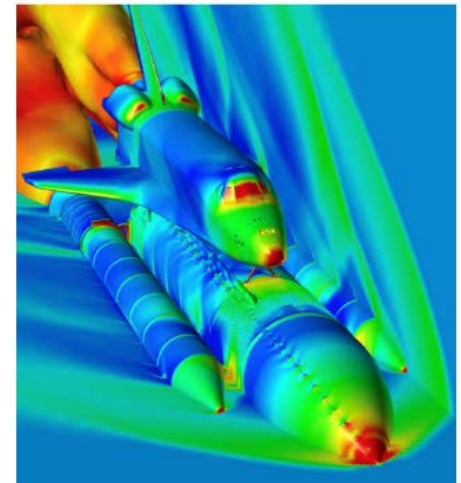
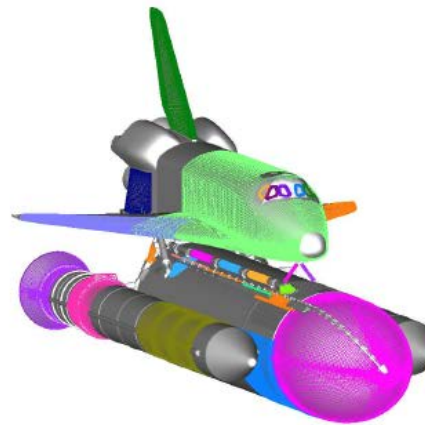
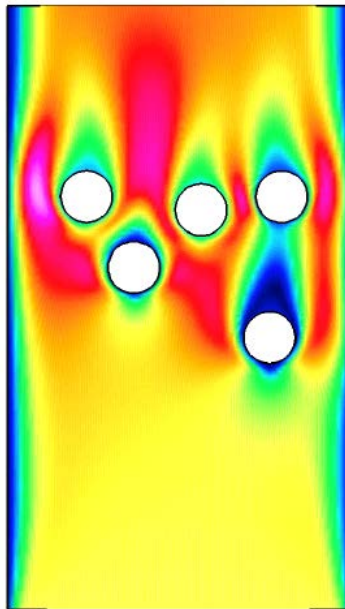
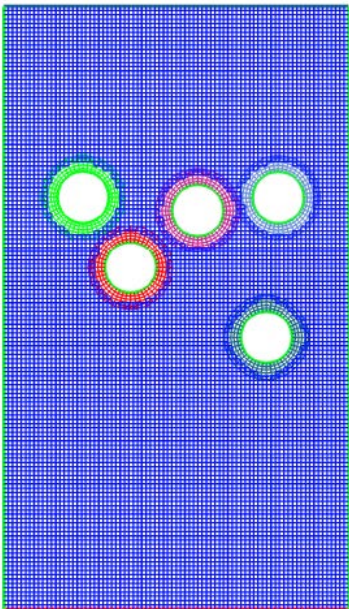

“An Introduction to Overset Grids” by Bill Henshaw, 2011 Space Shuttle figures by William Chan and Reynaldo Gomez

- One potential problem is surface assembly errors for overlapping grids with viscous spacing at the body surfaces
 - Overlapping surface grids have different resolutions and representation of the same geometry. This can result in the erroneous marking of points near the surface as holes or failure to find the correct donor information
 - One fix is to adjust the grid points of one grid so that they are consistently located relative to the discrete grid (within a specified tolerance)

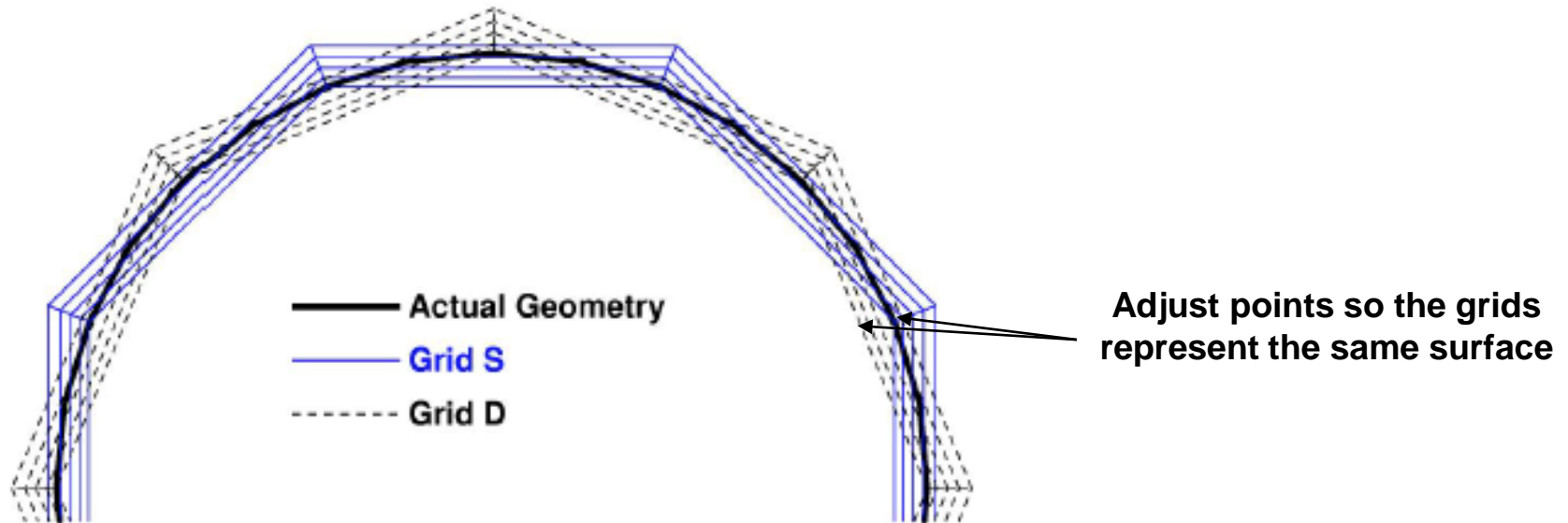

From SUGGAR Users Guide V2.52 by Ralph Noack

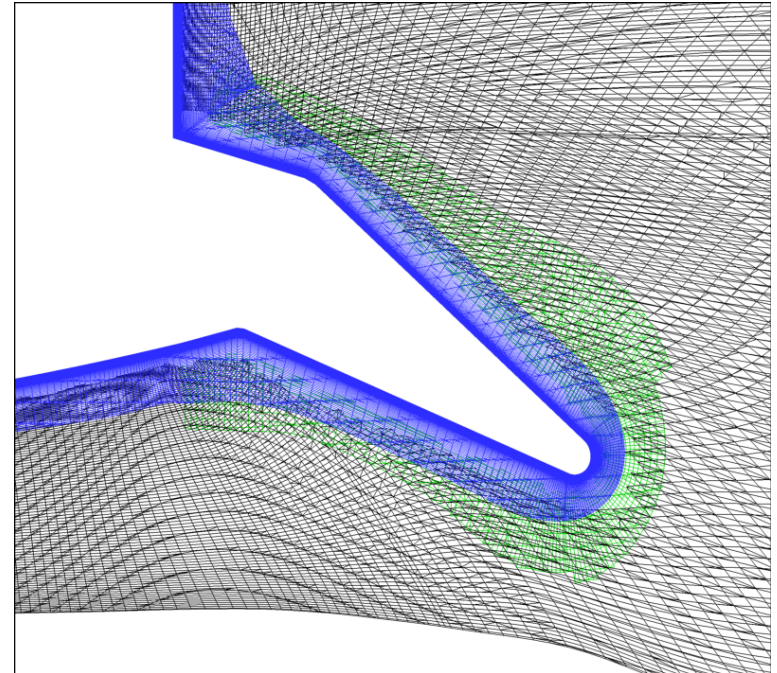
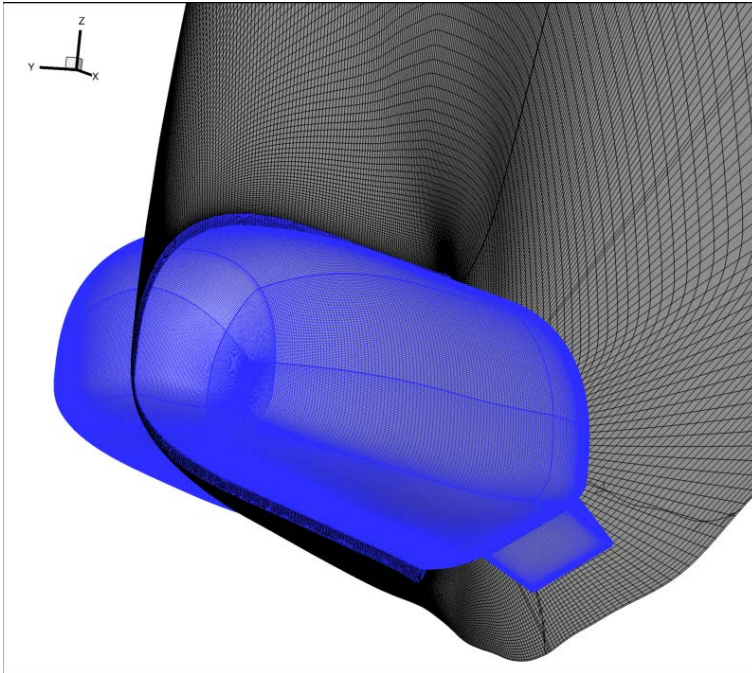

Overset grids for Mid-L/D configuration

- Total of 55 million grid points
- Hyperbolically generated meshes using Gridgen: point-matched, near-body grids (**blue**); shock-aligned, point-matched background grids (**black**) from a smooth "no flap" geometry; interface grids around flap region (**green**) to fill gaps between near-body and background meshes
- No surface assembly issues since grids are point-matched. No need to "stitch" surface grids to create a watertight surface for force and moment integrations
- Grid sequencing is straightforward. It was used to reduce the computational costs of running these simulations

Overset *DPLR* simulations for Mid-L/D configuration

- Laminar and turbulent SST simulations
- 8-species chemistry model for Mars (by Mitcheltree)
- Assuming fully-catalytic CO₂ model and radiative equilibrium at the wall
- Results were time-averaged
- Each simulation took around 20 walltime hours using 1,200 cores on NASA's Pleiades system

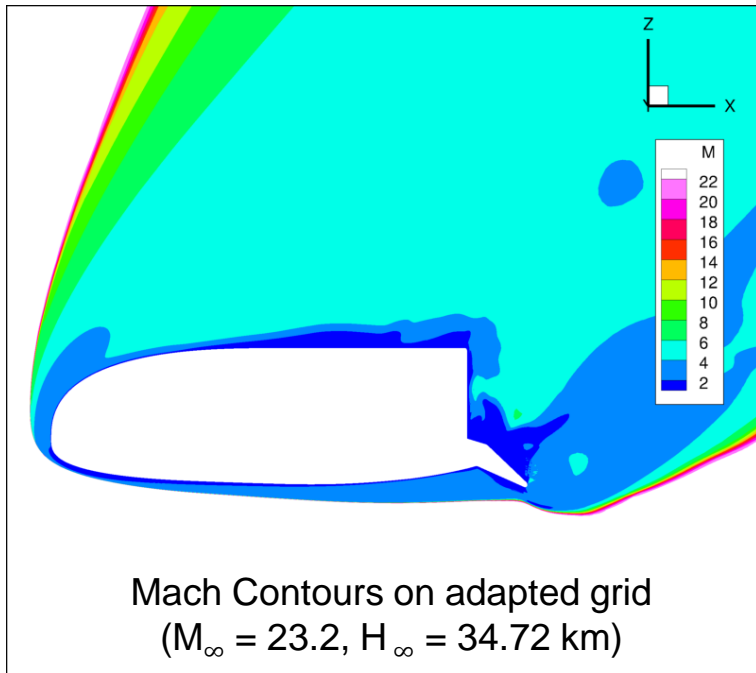

Initial solution

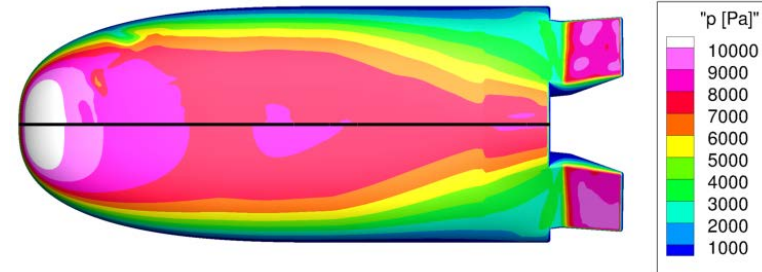

Adapted solution

Surface pressure (laminar solution)

Initial solution

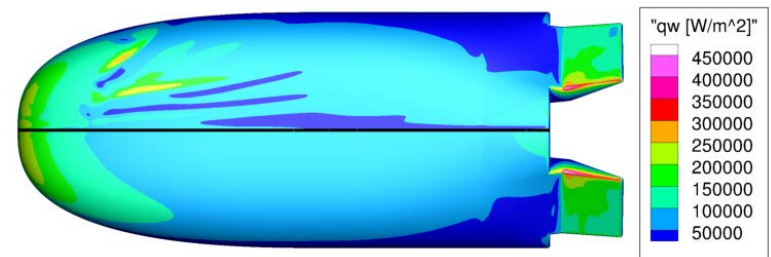

Adapted solution

Surface heat flux (laminar solution)

$M_\infty = 28.9$, $H_\infty = 38.32$ km
(laminar solutions)

Pressure contours

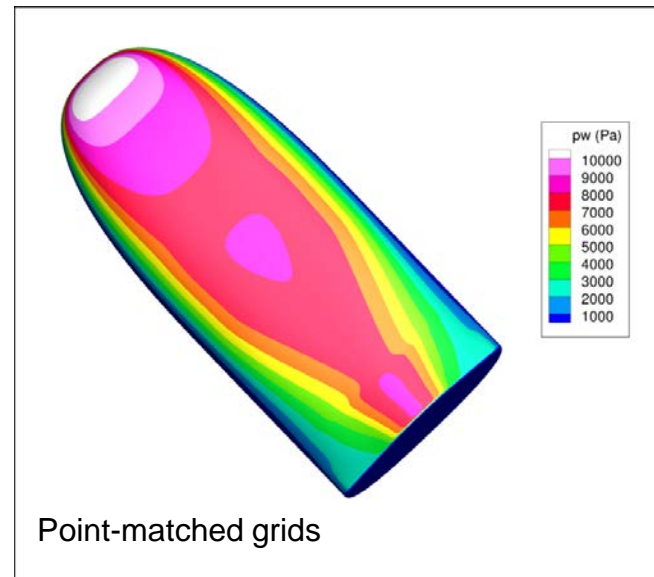
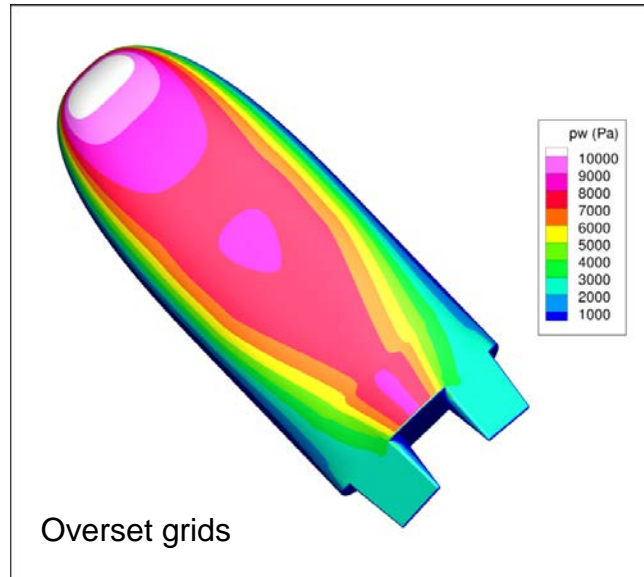

Heat flux contours

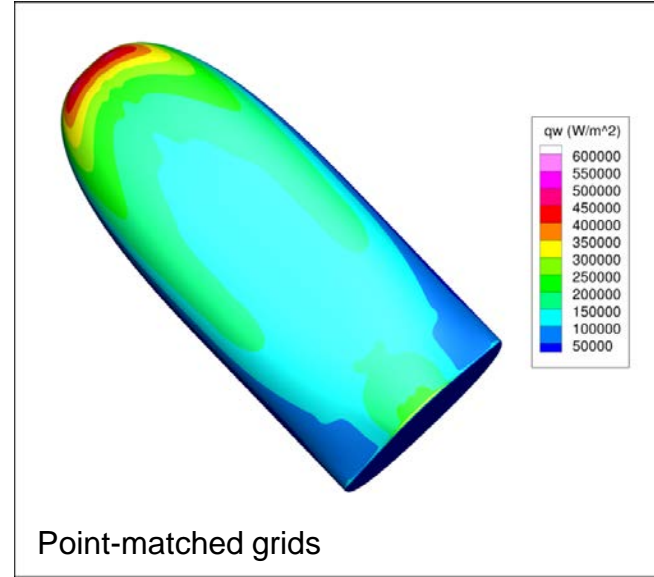
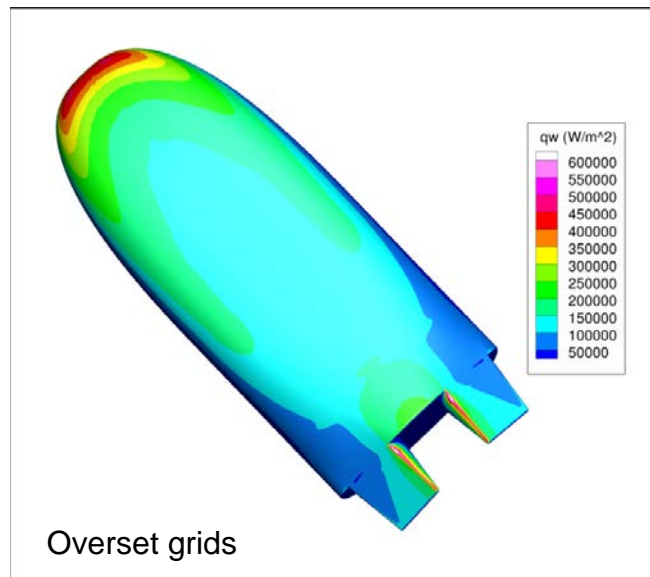

Concluding Remarks

- Proposed overset approach for *DPLR* can significantly reduce the time required for grid generation on complex geometries
- This process reduces the complexity of hole-cutting and eliminates any surface assembly issues. This straightforward approach makes the overset framework more accessible for new users
- Overset grids can be sequenced and shock-aligned for accurate estimates of the aerothermal environment. Overset meshes can be reused for other simulations
- CFD solutions were presented for a Mid-L/D configuration. The overset solutions are in excellent agreement with results from point-matched volume grids



Future Work



- Update *DPLR* and post-processing tools for overset grids
 - Modify build-in grid alignment subroutines in *DPLR* to allow mesh alignment for overset grids
 - Update post-processing tools that extracts volume solutions (such as *BLAYER*) to accommodate overset grids
- Extend *NEQAIR* (radiation code) for overset grids



Questions?