

Upgrades to the International Space Station Urine Processor Assembly

Jill P. Williamson¹, Layne Carter², Jimmy Hill³, Davey Jones⁴, Danielle Morris⁵, Rex Graves⁶
NASA George C. Marshall Space Flight Center, Huntsville, Alabama 35812, USA

The ISS Urine Processor Assembly (UPA) began operations in November 2008. Though the UPA has successfully generated distillate from crew urine, several modifications and upgrades have been implemented to improve overall system performance throughout the years. Current and future upgrades to the UPA will continue to focus on improved system performance and reliability, focusing primarily on the Distillation Assembly and upgrades to the UPA vacuum pump. Work towards a flight demonstration experiment of a vacuum pump utilizing scroll pump technologies has also continued forward. The following paper discusses progress on these various concepts, including the implementation of a more reliable drive belt, improved methods for managing condensate in the stationary bowl of the Distillation Assembly, installation of improved centrifuge bearings, implementation of a liquid level sensor, and upgrades to the UPA vacuum pump.

Nomenclature

<i>cm</i>	=	centimeter	<i>PPSA</i>	=	purge pump separator assembly
<i>DA</i>	=	distillation assembly	<i>psig</i>	=	pound force per square inch, gauge
<i>FCPA</i>	=	fluids control and pump assembly	<i>SPA</i>	=	separator plumbing assembly
<i>ISS</i>	=	international space station	<i>UPA</i>	=	urine processor assembly
<i>MSFC</i>	=	marshall space flight center	<i>WPA</i>	=	water processor assembly
<i>ORU</i>	=	orbital replacement unit	<i>OGS</i>	=	oxygen generation system
<i>PCPA</i>	=	pressure control and pump assembly	<i>WRS</i>	=	water recovery system

I. Introduction

The International Space Station (ISS) Water Recovery and Management System provides potable water for crew drinking and hygiene activities, oxygen generation, urinal flush water, and various payloads. To this end, wastewater is collected in the form of crew urine, humidity condensate, and Sabatier product water and subsequently processed by the Water Recovery System (WRS) to potable water quality standards. This product water is provided to the potable bus for the various users. The WRS is comprised of the Urine Processor Assembly (UPA) and Water Processor Assembly (WPA), which are located in two International Standard Payload Racks named WRS-1 and WRS-2 as shown by Figure 1. The layout of the two WRS racks is as shown in Figure 1, along with the Oxygen Generation System (OGS). The WPA is packaged in WRS Rack 1 and partially in WRS Rack 2, linked by process water lines running between the two racks. The remaining portion of WRS Rack 2 houses the UPA. Detailed process descriptions and schematics of the entire WRS are provided elsewhere^{1,2}.

¹ ISS Urine Processor Sustaining Lead, MSFC ES62

² ISS Water Subsystem Manager, MSFC ES62

³ MSFC ECLSS Mechanical Design and Analysis Lead Engineer, MSFC ES21

⁴ MSFC UPA Upgrades Project Manager, MSFC HP30

⁵ MSFC ECLSS Testing and Development Deputy Branch Lead, MSFC ES62

⁶ MSFC ISS ECLSS Development and Integration Project Manager, MSFC HP30

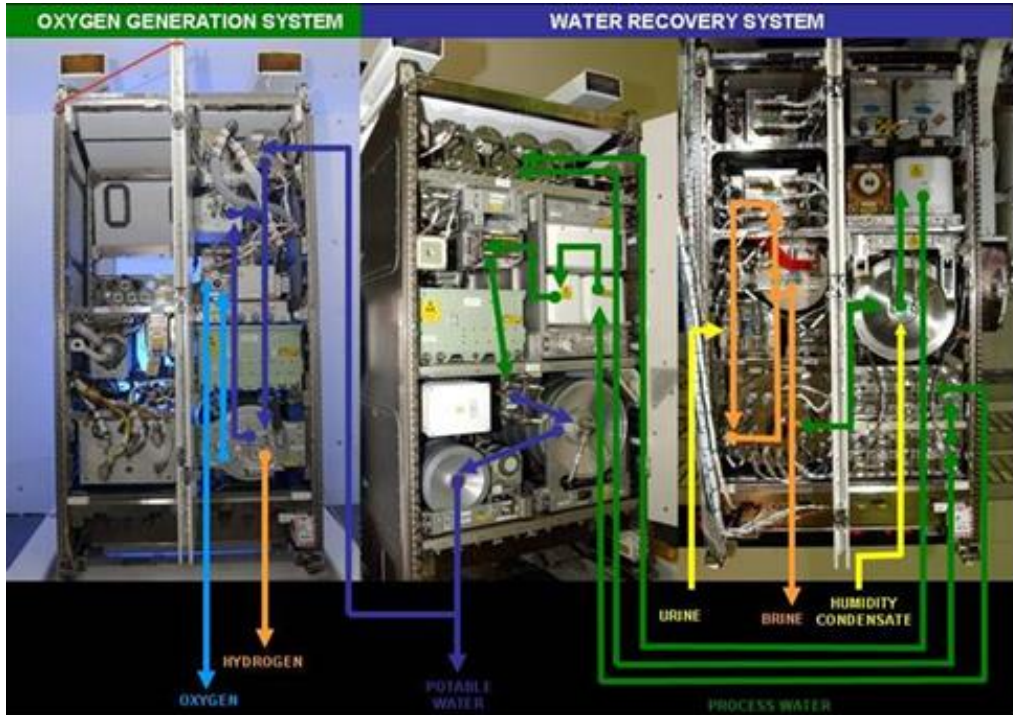

Figure 1. International Space Station Regenerative ECLSS Racks and process flows for the OGS and WRS.

II. Status of UPA Upgrades

NASA MSFC Engineering completed an extensive evaluation of the UPA hardware in 2017 to identify all areas in which improved reliability would better position UPA as a viable technology for future missions. These areas were prioritized and an agreement was reached with the ISS Program Office to fund those that provided the highest return on the investment. Once developed, these upgrades will be incorporated into ISS UPA ORUs to collect extended performance demonstration in an operational flight environment. Successful demonstrations will provide tangible life cycle cost benefits to the ISS over its remaining operational life and increase confidence that the UPA design can meet demanding exploration mission needs.

A. Distillation Assembly Design Upgrades

1. Drive Belt Redesign

Rotation of the DA is currently driven by an O-ring belt (Figure 2). However, this belt frequently slips during operation due to the steam environment in the DA. The risk is greatest at the beginning of a process run, since the steam has time to condense as the DA cools between processing cycles. Belt slippage at startup has been consistently observed in UPA operations on ISS. In February 2016, DA SN002 experienced a failure when the belt was unable to maintain sufficient centrifuge speed. This occurred after several months of off-nominal UPA performance in which the DA was consistently challenged with excess condensate in the stationary bowl^{2,3}. The current DA SN005, installed April 2017, has also experienced belt slip during startup; however, centrifuge speeds have continued to recover upon restart. These events coupled with the consistent slips on startup led to the objective of replacing the O-ring drive belt with a more robust design.



Figure 2. The DA O-ring drive belt.

MSFC engineering has considered V-belt and toothed belt designs to improve the drive belt reliability. A V-belt theoretically increases the contact area between the belt and the pulley, and could be implemented within the existing DA envelope. The V-belt is an extruded and spliced belt, as opposed to the molded O-ring belt. Figure 3 shows the varied profiles of the belts within the DA. The V-belt was tested first at MSFC to ensure it provided at least the same strength as the O-ring belt. However, initial testing of the V-belt design demonstrated limited success especially with the higher torque demands resulting from additional dynamic seals installed in and around the rotating centrifuge. This concept is no longer being pursued as a potential redesign solution.

The toothed belt is a synchronous drive belt where no friction is required to transmit power, unlike that of the O-ring and V-belt design. Not only would the toothed belt provide near 100% efficiency in transmitting power, but is expected to handle increased loads on the drive system due to other DA seals upgrades. Integrating this toothed belt into the design required a redesign of the compound pulley and an added tensioner. Figure 4 shows the toothed belts along with a 3D printed pulley and tensioner, used during fit checking. Ground testing has logged well over 600 hours of the new synchronous drive belt system with expected performances of 100% power transmission. Additional testing with dynamic sealing described later, where increased loads were expected, the toothed belt design effectively managed the higher torque demand and power transmission. Going forward, the implementation of the toothed belt design, not the V-belt approach, will be used in the next generation DA.

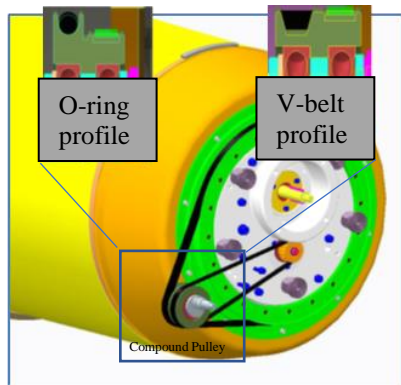

Figure 3. Drive belt redesign for V-belt.

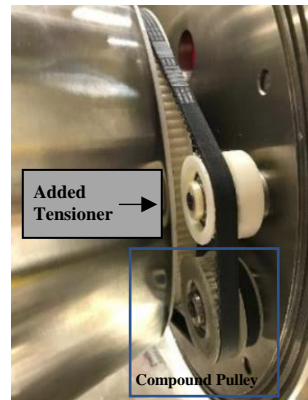

Figure 4. Toothed synchronous drive belt

2. Seal Bearing Leak Path

NASA personnel identified a leak path through the rear bearing in 2016/2017 that resulted in elevated conductivity in the distillate delivered to the Water Processor Assembly (WPA). This contaminated distillate presented significant operational impacts to both the UPA and WPA. Previous inspections of DAs returned from ISS have shown the grease in this rear bearing is washed out by pretreated urine during operation, but this is the first time that a leak of this magnitude impacted UPA operations. The subsequent investigation of the returned DA at MSFC could not identify

any mechanical variances with this DA that would explain why pretreated urine leaked through the rear bearing at a measurably greater rate compared to previous DAs operated on ISS. Despite the inconsistency, NASA personnel agreed that it is imperative to address this leak path by the addition of a lip seal to protect the rear bearing from exposure to pretreated urine. In the initial design of the DA at MSFC, three lip seals were located on the centrifuge shaft (rear bearing at the centrifuge hub, the motor bearing and the demister) to protect various bearings from exposure to pretreated urine. However, these lip seals introduced drag on the centrifuge that increased the risk of belt slippage, and as a result, the lip seals at the rear bearing and motor bearing were removed before the UPA was initially installed on ISS. In response to the anomalous operation on ISS, MSFC engineering has measured the drag introduced by the lip seal and determined it will contribute to additional belt slippage with the current O-ring drive belt. Incorporating this lip seal design into the next on-orbit DAs depends on the success of the drive belt redesign described earlier. In fact, the introduction of the new toothed synchronous drive belt during ground testing has shown sufficient performance margin to accommodate the drag associated with the installation of the lip seals. Based on this finding, the additional lip seal on the rear bearing will be implemented in the upgraded DA.

3. *Liquid Level Sensor Tip Redesign*

The liquid level sensor was included in the original design to determine when the fluid layer in the evaporator is thicker than expected. This could indicate an issue with the fluids control and pump assembly (FCPA) or an obstruction that is flooding the evaporator. The sensor works as intended in ground testing, but does not work as expected in microgravity. Sensor data shows erratic readings, likely due to droplets of pretreated urine splashing on the sensor during operational transitions (starting up or shutting down). The tip of the sensor has been redesigned with a non-metallic shield to minimize the possibility of droplets reaching the sensor. Figure 5 highlights, in green, the redesigned liquid level sensor shield.

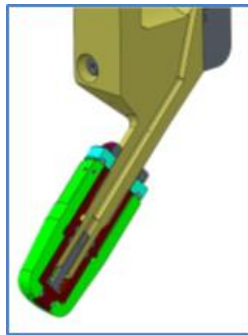

Figure 5. Shield design for protecting liquid sensor from droplets.

4. *Implement Seal to Stationary Bowl*

Condensate in the stationary bowl has been a consistent issue for the DA. As the water vapor is generated in the evaporator, it is pumped to the condenser by the DA's compressor. The condenser rotates within the DA's stationary bowl, but there is a gap of 0.16 cm between the condenser and the compressor. This gas then allows water vapor to leak into the stationary bowl. Over time, the bowl will become saturated with water vapor, at which time it will condense on the cooler surfaces. This condensation is detected by temperature sensors, which subsequently turn on the stationary bowl heaters to drive the water back to the vapor phase before it can introduce a drag to the centrifuge. These heaters consume approximately half of the UPA power, which is highly undesirable for future missions. Furthermore, this heat increases the operating temperature and pressure of the DA, which reduces the DA efficiency and can result in a shutdown if the vacuum pump cannot get the pressure below the required setpoint. In addition, the O-ring drive belt is located in the stationary bowl. MSFC engineering believe the primary reason the drive belt tends to slip on startup is because of condensation occurring during standby. For these reasons, MSFC engineering has pursued multiple options to reduce the quantity of water vapor that can leak into the stationary bowl.

The primary option to mitigate this issue is the addition of the Trelleborg VariSeal to the gap between the condenser and the compressor. This seal will reduce the gap from 0.16 cm to 0.0 cm; therefore, significantly reduce the amount

of the water vapor that leaks into the stationary bowl. The critical design issue with this seal is to ensure it does not introduce significant additional drag to the centrifuge rotation that would increase current draw on the DA motor. Modifications to the aft plate of the compressor are required to accept the VariSeal have been completed. Figure 6 shows the VariSeal installation for the stationary bowl.

Initial testing of a VariSeal lip seal design within the DA with O-ring drive belts took place at MSFC in late 2018. After 100 hours of nominal operation with the VariSeal, approximately 65 mL of fluid was collected in the stationary bowl. In previous test operations over similar run time without the seal, over 1700 mL of fluid was reported. This confirms a significant improvement to minimizing water vapor from entering the stationary bowl by reducing the gap. Further parametric testing continued, only now, with the installation of the toothed synchronous belt drive system. It is believed the remaining 65mL found was due to another known leak path on the aft end of the centrifuge. A custom design solution has been determined with support from Trelleborg. The seals are currently being manufactured by Trelleborg as well as necessary MSFC design changes to support initial testing on the development DA unit. Disassembly of the DA after a subsequent parametric testing revealed shedding of the VariSeal material due to contact between the centrifuge and compressor aft. Figure 7 shows the flaking nature of this shedding within the DA. It is believed the material make-up of this particular VariSeal was the cause for this shedding. An alternate material (T40) has been chosen and procured for later testing. It is hopeful shedding will be reduced, if not minimized, and fluid reduction in the stationary bowl performance is maintained. Despite the shedding issue, the VariSeal has shown promise in mitigating the amount of fluid in the stationary bowl. Overall, 95% reduction of fluid in the stationary bowl was observed compared to a baseline performance without the seal and no heaters. Moreover, MSFC Engineering will consider a break-in procedure of these VariSeals to address observed drag during parametric testing.

Further efforts to decrease this leak path incorporates a Teflon seal instead of the VariSeal at the same location. Acting as a spacer, a thin Teflon ring design can be a compromise to reduction of water vapor into the stationary bowl while avoiding the potential for material shedding. Similar Teflon seal design is already incorporated on the hub end of the DA, which proves a viable sealing option within this dynamic environment. These Teflon seal designs reduce in gap size at the interface, which should reduce the amount of water vapor. Because there is no material touching the moving surfaces, there is no concern for shedding or increased drag onto the system. Ground testing installed a Teflon seal achieving a 75% reduction in gap, which has shown similar reductions of fluid found during the VariSeal testing. Ongoing testing with the Teflon seal, with respect to thicknesses and runtime, will provide better comparisons to previous VariSeal testing.

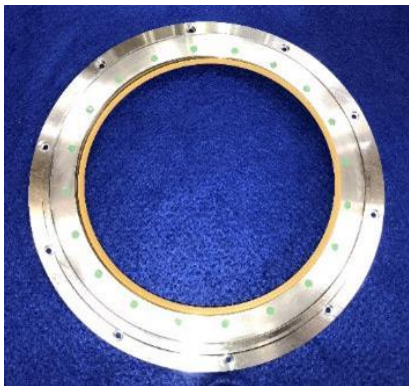

Figure 6. VariSeal for stationary bowl.



Figure 7: VariSeal shedding in centrifuge assembly after 200 hours of runtime.

5. *Thermal Isolation of Front Plate*

Though the stationary bowl seal will reduce the amount of water vapor that leaks into the stationary bowl, for now, it is not expected to eliminate it. One of the areas of primary concern for condensation is on the DA's front plate, which is typically colder than the rest of the stationary bowl because of its proximity to the coolant line used for the DA motor. The front plate is located directly in front of the drive belt, such that condensation in this area puts the belt at increased risk for slippage. To reduce the potential impact of condensed water on the drive belt, MSFC engineering is installing a Torlon thermal isolator between the front plate and the coolant line. This new material thermally isolates the conductive path from the motor to the compressor. Initial ground testing has shown increased temperatures, by up to 20 degrees Fahrenheit on the compressor endplate, confirming effective thermal isolation.

6. *Insulation of Centrifuge*

When condensation occurs in the stationary bowl, the heaters are automatically turned on to evaporate the condensed water. The heater from this operation reduces the latent heat exchange between the condenser and evaporator volumes, which affects operation of the DA as pressures increase and the distillation/condensation process becomes less efficient. To reduce the effect of the heaters on the DA operation, MSFC engineering is evaluating insulating the centrifuge. The critical concern with this approach is the effect of the insulation on the centrifuge balance. The insulation will need to be a closed cell foam to prevent adsorption of water, which would affect centrifuge balance and provide an environment for microbial growth. The insulation blanket has been designed and manufactured, but testing with this upgrade is on hold until MSFC engineering can assess if the seal on the stationary bowl is sufficient to address the concern.

7. *Nitinol/Hafnium Bearings*

The centrifuge and compressor bearing material has been a critical design issue since the original design of the DA. The initial bearing material (Stainless Steel 440C) was replaced with Hastelloy C-276 bearings during the design phase because of concerns with material corrosion when exposed to the pretreated urine. However, the compressor bearings failed when the DA was initially operated on ISS in November 2008 because the corrosion-resistant material lacked the structural strength to withstand the loads imparted during installation, launch, and operation. As a result, they were replaced with Cronidur bearings. Though these bearings have not failed, engineering personnel have noted obvious signs of wear during disassembly of DAs returned to ground after use on ISS. In addition, the bearings cannot be removed from a flight DA after they are installed without risking damage to the bearing that would make it unacceptable for the flight unit. Because of these reasons, NASA engineering has found a nitinol/hafnium bearing that should provide similar corrosion resistance but significantly improved strength in not only the Compressor Assembly but for the Centrifuge Assembly as well. These bearings are currently in procurement with plans to test in the UPA development unit in 2019, in parallel with materials testing to ensure compatibility with the pretreated urine.

B. PCPA Design Upgrades

A persistent problem on ISS has been the short life span of UPA pumps. The most prevalent failure has been harmonic drive failure for FCPA, but pressure control and pump assembly (PCPA) units have always failed from tube rupture without achieving the desired lifetime. Better strategies for thermal management and alternative pump architectures are under consideration for upgrades.

1. *Purge Pump Separator Assembly (PPSA)*

The peristaltic pump was previously selected for the vacuum pump because it could pump two-phase flow and the peristaltic tubing was compatible with the fluid composition (water, water vapor, and noncondensable constituents from the pretreated urine). However, the peristaltic pump is relatively large and is challenged to maintain the vacuum required for the DA operation, especially when excess gas (either dissolved or free) is fed to the UPA or when the stationary bowl heaters are powered to remove condensate in the stationary bowl. With respect to scroll pumps, early technology did not effectively deal with the two-phase fluid coming through the purge line. However, NASA personnel have identified a scroll pump that provides improved efficiency compared to the peristaltic pump that is currently in the PCPA. The unique design of the pump head allows it to process liquid and gas simultaneously while

starting up against the vacuum maintained by the DA and pumping against the backpressure (~4 psig) required to push the purge distillate through the Separator Plumbing Assembly (SPA) and into the distillate delivered to the WPA. This pump provides more capacity than the current peristaltic pump while requiring about 1/3 of the power for operation.

Sufficient ground tests have been completed to merit a technology demonstration of this hardware on ISS. Though the materials used in the scroll pump head were acceptable for ground tests, they will have to be upgraded for a flight unit to ensure compatibility with the potentially corrosive liquid this pump may be exposed to. In addition, NASA MSFC is selecting a new motor for the pump to meet performance and life requirements for this application. The new motor/pump assembly will be significantly smaller than the current peristaltic pump, providing sufficient volume for integrating the current SPA ORU with the new scroll pump. This integration is desirable because currently the SPA ORU has to be replaced in its entirety when the SPA membrane reaches end of life. This is a significant mass penalty given the SPA membrane itself weighs less than 1 kg. By integrating the new scroll pump with the components in the SPA ORU (including the SPA membrane, a regulator, the purge filter, and a manifold), approximately 27 kg (60 lbs) of mass will be saved. Moreover, additive manufacturing efforts are being pursued which will further reduce the overall mass.

The scroll pump assembly and manifold have been used during brine productions and other test series during the past year. Current ground testing has logged well over 400 hours on the scroll pump, maintaining adequate vacuums in the UPA system with no significant performance degradations reported. Other considerations for the PPSA will address recent coolant loop pressure differential measurements across the scroll pump. Fortunately, the delta pressures observed are not significant and minor redesigns may be requested to maintain requirements.

This new hardware will provide the means to remove and replace the scroll pump, the SPA membrane and the purge filter without replacing any of the ORU's structural frame. This hardware is currently anticipated for delivery to ISS in 2020 for a functional demonstration.

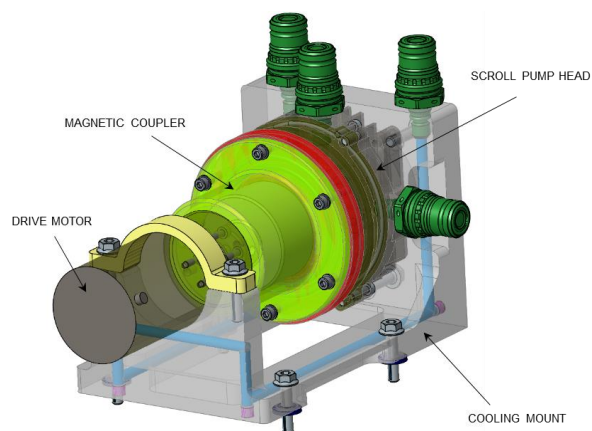

Figure 8. Scroll pump for UPA Technology Demonstration.

III. Conclusion

The ISS Urine Processor Assembly (UPA) is the preferred NASA technology for future manned missions beyond ISS. However, based on the over 10 years of operation on ISS, the reliability of this hardware may be improved in several areas. An upgrade to the peristaltic pump from a harmonic drive to a planetary gear drive has already provided a marked improvement in pump life on ISS. Additional upgrades as outlined in this paper are currently being designed and implemented in the UPA Development Unit at NASA MSFC. These upgrades will be tested in 2019 before deciding which modifications will be fully implemented in flight hardware and demonstrated on ISS. Based on the current schedule, desired DA upgrades will be implemented in the next DA build-up and delivered to ISS early 2020. The PPSA technology demonstration will be delivered to ISS in September 2020.

Acknowledgments

The authors would like to acknowledge the design and test engineers at MSFC that are developing and evaluating the hardware upgrades addressed in this paper.

References

¹Pruitt, J.M., Carter, D.L., Bagdigian, R.M., and Kayatin, M.J., "Upgrades to the ISS Water Recovery System," ICES 2015-133, *45th International Conference on Environmental Systems*, Bellevue, Washington, 2015.

²Carter, D.L., Williamson, J, Brown, C., Bazley, J., Gazda D., Schaezler, R., Thomas, F., "Status of ISS Water Management and Recovery", Paper # 2018-088, *48th International Conference on Environmental Systems*, Albuquerque, New Mexico, July, 2018

³Carter, D.L. J.M. Pruitt, C. Brown, J. Bazley, D. Gazda, R. Schaezler, L. Bankers, "Status of ISS Water Management and Recovery", Paper # 2016-017, *46th International Conference on Environmental Systems*, Vienna, Austria, July, 2016