



# Simulation of InSight Plume Induced Surface Cratering and Validation Through Imagery Based 3D Topology Reconstruction

Manish Mehta<sup>†</sup> and Michael Manginelli<sup>†</sup>, Aerosciences Branch  
Peter A. Liever<sup>†\*</sup>, Manuel Gale<sup>†\*</sup> and Doug Westra<sup>†</sup>, Fluid Dynamics Branch  
Orrin Thomas<sup>#</sup>

<sup>†</sup>NASA Marshall Space Flight Center/<sup>\*</sup>CFDRC/<sup>#</sup>Cardinal Systems, LLC

July 9th, 2019



InSight

JPL



LOCKHEED MARTIN



- Stereo-models generated using:
  - Radial distortion models provided by InSight Instrument Deployed Camera, IDC (Justin Maki)
  - XYZ & quaternions provided by InSight IDC (Rob Grover)
  - Ground control points (GCPs) provided by LM high-fidelity CAD (Mark Johnson)
  - 8 non-stereo images taken from the PSI dedicated IDC imaging campaign (InSight Surface Ops)
    - Camera's XYZ location and rotation matrix changed from image to image creating pseudo-stereo pairs
    - Led to more challenges and uncertainty in generating stereo-models
- Surface mapping
  - Import stereo-models
  - Map points and lines on the surface
  - Generate Digital Terrain Map (DTM)
  - Output volumes and dimensions
- Accuracy/uncertainty quantification

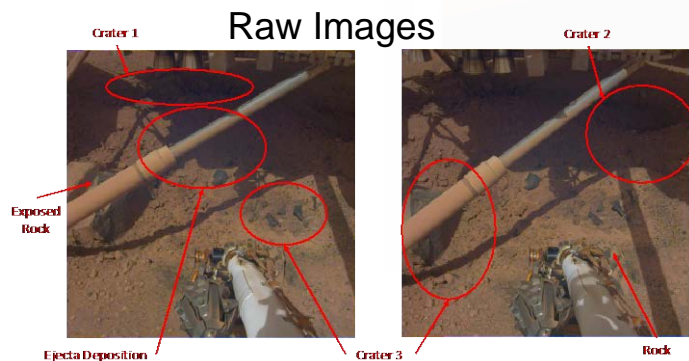
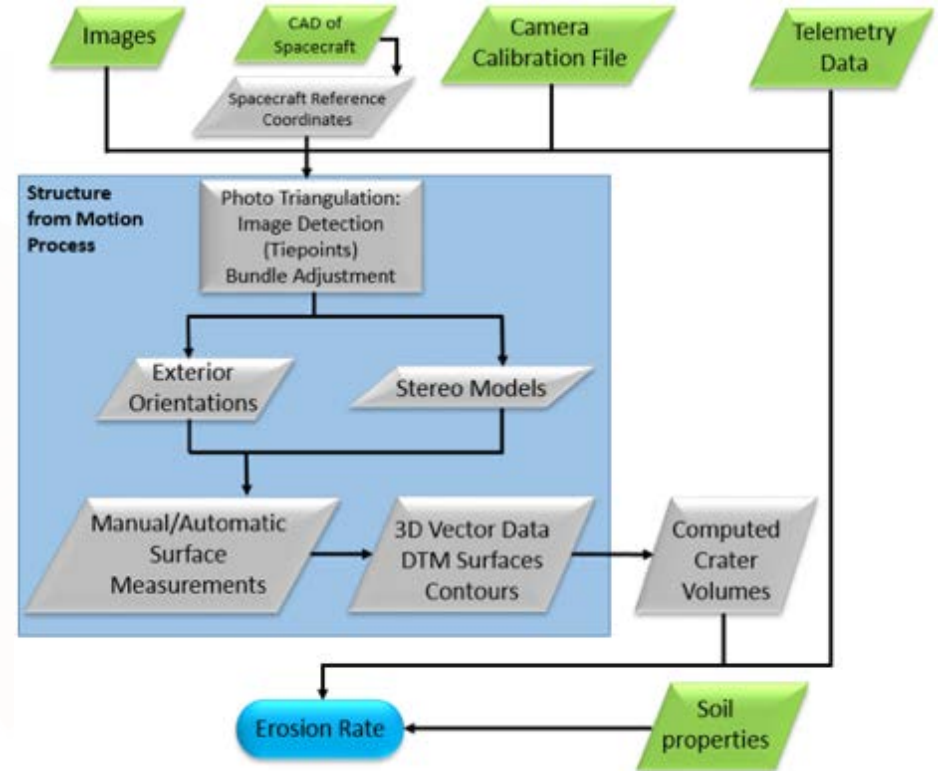
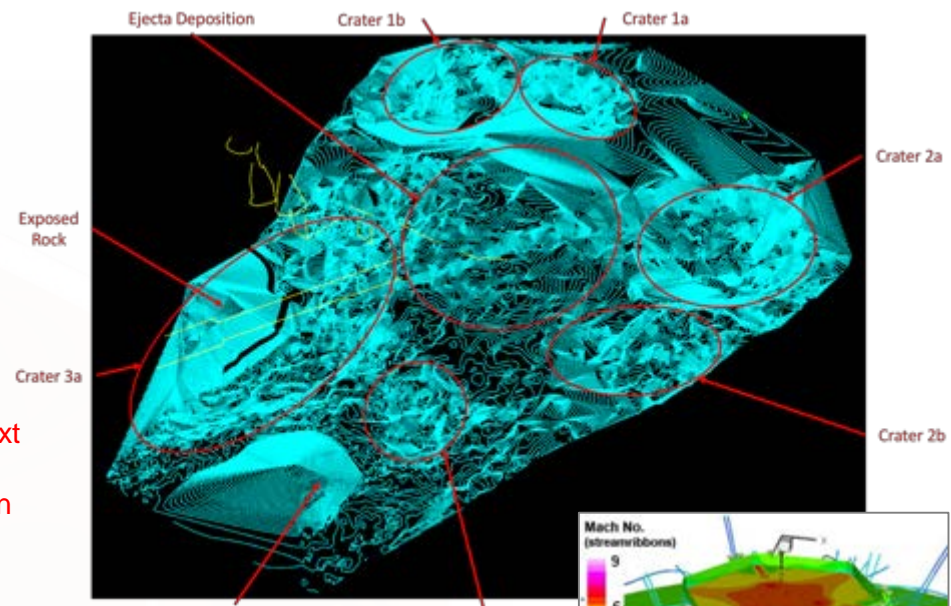
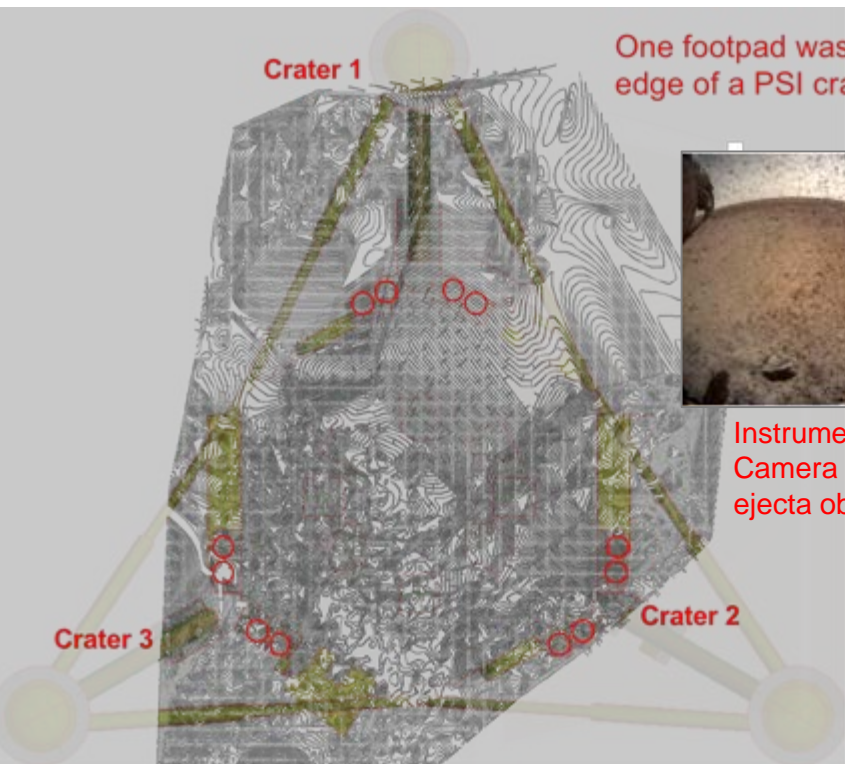

Image Processing  
Photogrammetry



- DTM
- Crater Volume
- Erosion Rates





Length scale accuracy based on comparisons with GCPs:  $\pm 0.1$  in

Gulick (2006), Lockheed Martin

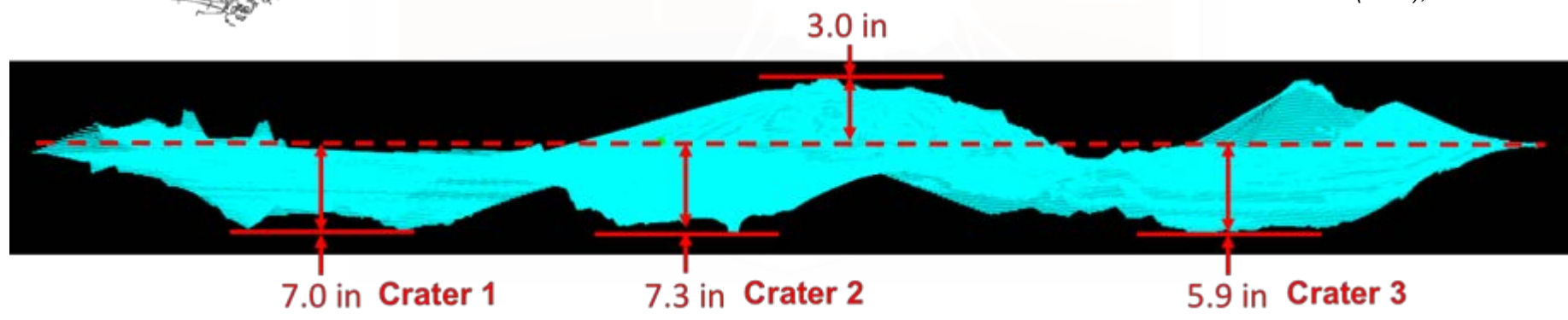

Lander	Crater	Max Depth	Average Diameter	Eroded Volume	Average Erosion Rate	Peak Thrust
InSight	Crater 1	7.0 in	20.1 in	2203 in <sup>3</sup>	56.2 lb <sub>m</sub> /s	270 lb <sub>f</sub>
	Crater 2	7.3 in	21.1 in	1902 in <sup>3</sup>	48.6 lb <sub>m</sub> /s	
	Crater 3	5.9 in	22.7 in	1809 in <sup>3</sup>	46.2 lb <sub>m</sub> /s	
MSL	Goulburn	2.6 in	52.4 in	665 in <sup>3</sup>	1.93 lb <sub>m</sub> /s	371 lb <sub>f</sub>
	Burnside	2.0 in	68.5 in	3283 in <sup>3</sup>	9.51 lb <sub>m</sub> /s	
	Hepburn	2.9 in	78.7 in	3881 in <sup>3</sup>	11.2 lb <sub>m</sub> /s	
	Sleepy Dragon	4.0 in	88.2 in	5167 in <sup>3</sup>	15.0 lb <sub>m</sub> /s	

- Three large PSI craters observed
  - Two sub-craters per engine cluster supports ground pressure distributions from CFD
- Average InSight PSI crater diameter 21 inches and 7 inches deep
- Assume flat pre-landing terrain (agrees with photogrammetry results and surface ground points)
- InSight observed the deepest site alteration of all Mars landing missions to date due to:
  - Pulse-modulated engines
  - Loose and deep regolith landing site requirement
- InSight PSI erosion rate 5x that of MSL (assuming mean Mars soil bulk density)
- Footpad on Crater 1 rim
  - Could have led to a ~5° lander tilt if footpad settled within Crater 1
- Ejecta from craters impinged on the lander base and deposited in the center
  - Large ejecta flux could have damaged lander base instrumentation and led to significant ejecta obscuration on the ICC
- Can be used to qualitatively assess PSI effects for M2020 and MSR

- As part of InSight Lander EDL Reconstruction effort, the MSFC Fluid Dynamics Branch (MSFC-ER42) has been tasked to perform plume-surface interaction simulations with plume-surface interaction simulation tools available in the branch.
- Simulations are performed with the simulation framework combining the Loci/CHEM CFD and the Gas-Granular Flow Solver (GGFS) multi-phase particle flow simulation tools.
- The goal is to advance and mature the existing simulation tools and establish a validated capability to simulate and predict the plume induced surface regolith erosion and cratering to advice future lander development
- The scope of this effort includes pre- and post-landing activities:
  - Pre-landing simulation with best estimate of regolith properties and landing parameters
  - Post-landing validation and simulation refinement based on imaging, actual regolith characterization and resulting topology reconstruction from surface erosion/cratering imaging



- Animation shows instantaneous, highly unsteady impingement pressures
- Mean pressure profile predicted over full power segment of duty cycle indicates
- Distinct impact pressure regions with 10000-20000 Pa - Exceed regolith bed damage threshold
- Mean pressure levels are driver for regolith damage/activation leading to erosion and cratering

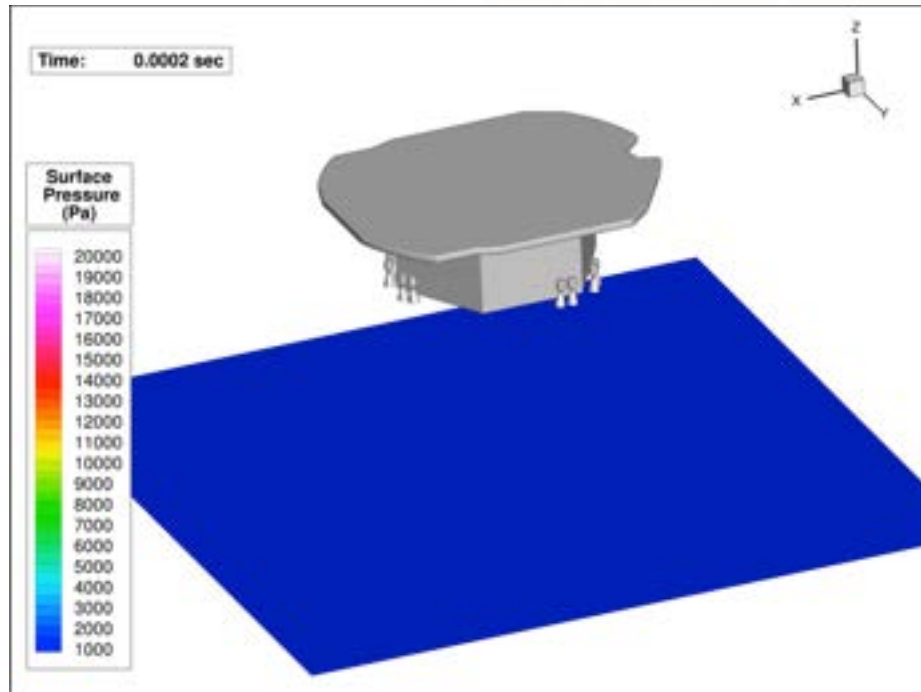

Animation, Instantaneous Pressure

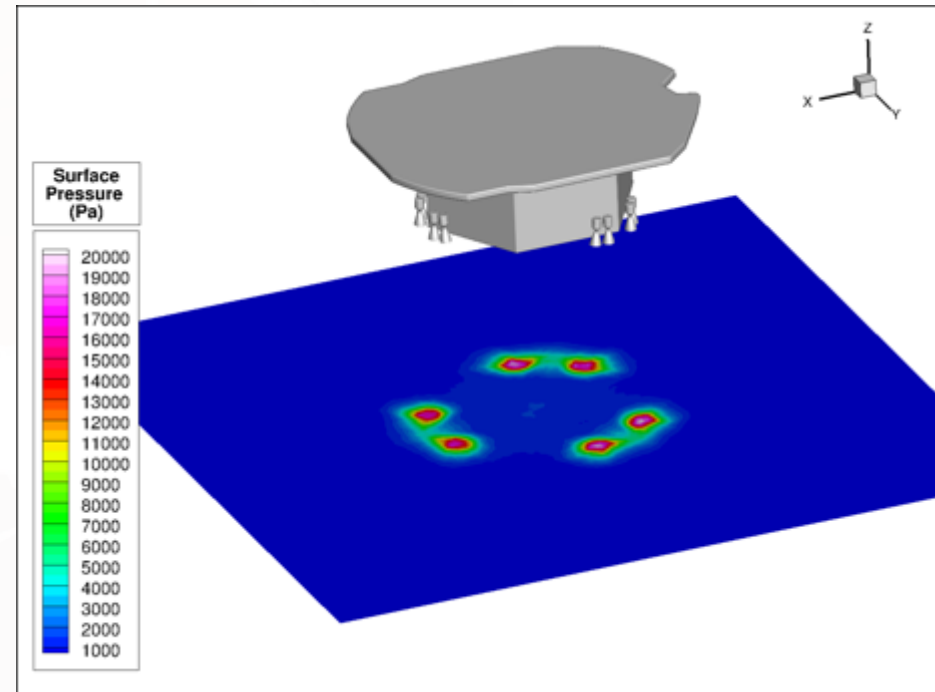

Mean Surface Pressure  
Averaged over full-power segment of duty cycle

- Added regolith layer to lower section of CFD domain to perform Gas-Granular Flow Solver (GGFS) cratering simulation
- Pre-landing surface regolith composition assumptions based on Golombek et al. 2008
  - Sandy regolith material estimated at particle size of 60-200 micron, bulk density 1000-1300 kg/m<sup>3</sup>
- Selection for initial, pre-landing simulation:
  - Monodisperse (single particle size) particle mixture, Spherical particle size at 200 micron, 1300 kg/m<sup>3</sup> bulk density, initial material packing ratio of 0.4

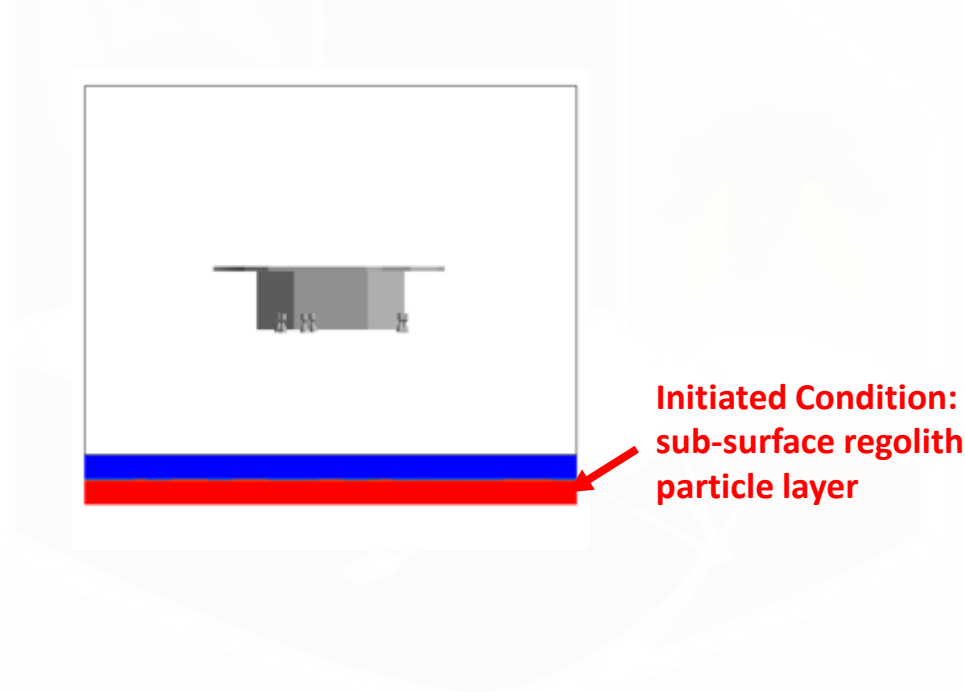

M.P. Golombek, et al., Martian surface properties from joint analysis of orbital, Earth-based, and surface observations, in *The Martian Surface: Composition, Mineralogy and Physical Properties*, ed. by J.F. Bell III. (Cambridge University Press, Cambridge, 2008), pp. 468–497. Chap. 21



- Animation depicts plume flow envelope iso-surface at  $M=1$  and regolith surface recession/cratering





- Multi-phase plume-surface interaction simulation of the InSight lander performed under InSight EDL reconstruction program
- Simulations are performed with plume-surface interaction simulation framework featuring the Loci/CHEM CFD and the Gas-Granular (GGFS) multi-phase particle flow simulation tools.
- Initial CFD-only simulation were performed of lander at fixed elevations of 2ft, 4ft, 8ft over hard ground surface model with pulsed engine flow modeling. Also performed moving lander terminal descent simulation.
- The 4-ft fixed elevation CFD model was selected to perform coupled plume-regolith cratering simulations with the GGFS simulation framework.
- Pre-landing surface erosion/cratering simulation performed with best estimate of InSight landing site regolith composition.
- Forward work: Improve regolith modeling by comparing/validating surface cratering topology against post-landing imaging and follow-up 3D surface stereoscopic reconstruction.

