



Final Report

**NASA X-HAB Space Habitat Research Group
Iowa State University**

14 May 2019

**IOWA STATE
UNIVERSITY**

	1
1 Document Scope	4
2 Executive Summary	4
3 Introduction	4
3.2.1 Overview	5
3.2.2 System Scope	5
4 Description of Final System	6
4.1 Requirements	6
4.2 Workflow Breakdown	6
5 Theory	7
5.1 Bed Depth Service Time	7
5.2 Gas Processors Suppliers Association (GPSA)	8
6 Baseline Design Solution	10
6.1 MOF Packed Bed	10
6.2 TRL – 4	13
6.3 TRL – 6	16
6.2.1 Adsorption	16
6.2.2 Desorption	17
7 Performed Design Analyses	18
7.1 MOF Chemisorption	18
7.1.1 Testing Procedure	18
8 Results Report	19
8.1 MOF Testing	19
8.2 4A Zeolite Testing	22
8.3 MOF PXRD Analysis	24
8.3.1 Thermogravimetric Analysis	24
8.3.2 ASC Report	25
9 Internal and External Interfaces	31
9.1 Internal Interfaces	31
9.2 External Interfaces	31
10 Physical Environment	32
11 Support Environment	33
11.1 Assembly and Cleaning	33
12 Operational Scenarios and Use Cases	34
12.1 Nominal Conditions	34
12.2 Off-Nominal Conditions	34
13 Impact Considerations	34
13.1 Organizational Impacts	34
13.2 Scientific/Technical Impacts	34
14 Risk Mitigation	36
TRL-4	36
TRL-6	37
15 Costs	38
15.1 Costs	38

15.1.1 Synthesis	38
15.1.2 Process	38
15.1.3 Design	39
15.1.4 Controls	39
16 Educational Outreach	40
17 Documents	41
17.1 Applicable Documents	41
17.2 Reference Documents	41
18 Appendices	42
A Acronyms	42

1 Document Scope

This document serves as the Final Report for Iowa State University's Space Habitat group to fulfill the specifications of NASA's eXploration Systems and Habitation (X-Hab) 2019 Academic Innovation Challenge for the 'Implementation of Advanced Sorbents in a Carbon Dioxide Management Unit' portion of the challenge. The scope of this document includes a description of the current Carbon Dioxide management systems implemented on ISS, a description of the group's design, a description of the operational environment and scenarios, risks and mitigations, performance and testing results of the system, outreach, and future work.

2 Executive Summary

The NASA X-Hab team at Iowa State received a \$30,000 Grant from NASA to design and fabricate a prototypical pressure swing CO₂ Scrubber using new MOF's that have not been used at low CO₂ concentrations of 2650 ppm. This project was led by Nevin Smalls and consisted of five different teams to achieve design goals. These teams were controls, design, chemical, process, and systems engineering. The team had two full academic semesters to complete the project with a delivered system due at the end of May. The project would be split into scheduled phases, with funds being proportioned accordingly.

3 Introduction

3.1 Project Description

3.1.1 Background

As the scope of NASA and other space agencies begins to shift focus to manned deep space missions, many environmental control systems will need retrofitted and redesigned for this more intensive application. NASA's X-Hab competition awards collegiate groups of students grants to research any of the various fields that are necessary for deep space travel. As Carbon Dioxide management remains one of the major components of a robust life support system, Iowa State University's Space Habitat group was awarded one such grant to research the usage of advanced sorbents in a CO₂ management system. The primary method of CO₂ management aboard the International Space Station (ISS) is the Carbon Dioxide Removal Assembly (CDRA). While this system has successfully kept crews alive since 2001, a number of issues have been identified that would need resolved before sending humans into deep space for longer missions.

One major concern is downtime due to maintenance. CDRA has had downtime several times since its installation due to repairs needed, usually involving valve replacement. Zeolite, the sorbent used to isolate CO₂, releases dust particles as it decomposes. These particles travel downstream and conglomerate at critical points, slowing airflow and eventually completely clogging valves. Because the zeolite decomposes as it is used, downtime is also required whenever new zeolite beds are needed to be installed.

Downtime is expensive, wastes valuable crew time, and puts the crew in danger.

Another concern is energy consumption. The method of desorption used by CDRA is a mixture of temperature and pressure cycles. When the zeolite is saturated, it is heated up to facilitate desorption and unbind the CO₂, then vacuum pressure is applied to pull it away. After desorption, the Thermal Control System (TCS) actively dissipates heat from the zeolite so that adsorption can again take place. This process of continual heating then cooling puts a burden on the energy supply of ISS, and on TCS, which is responsible for heat dissipation of various systems in ISS. It also accelerates the decomposition of the zeolite, further increasing the prevalence of maintenance issues.

The final issue the group looks to resolve is that of reusability. CO₂ isolated by CDRA is dumped overboard into space, as there are no storage or repurposing methods. In order for deep space missions to be feasible, minimal amounts of resources should be lost. Therefore, an updated system should be closed loop, and have some method of storing or repurposing captured CO₂.

The X-Hab group looks to research methods of resolving these identified problems by designing a system based around the use of advanced sorbents. In particular, the group will synthesize and test several types of Metal Organic Frameworks (MOFs) that have shown promise in the field of CO₂ management, but have not been extensively studied. This provides the rationale and goal for the group's research and design.

3.2 Overview of Final System

3.2.1 Overview

The group produced two baseline solutions at readiness levels of TRL-4 and TRL-6. The TRL-4 (test bench setup), which was used to test systems integration, verify correct MOF synthesis, and for other verification and validation purposes, was constructed and utilized by the team. Results from testing and verification are described in detail in Sections 7 and 8. The TRL-6 solution remains to be constructed in the future when results from rigorous testing from the TRL-4 setup are obtained and the design is optimized, and additional funding is applied to the project. Both designs are detailed in depth in Section 6.

3.2.2 System Scope

The scope of the system encompasses the synthesis, modification, and testing of Mg-MOF-74 produced, the design, construction and packing of packed beds, the design, testing and integration of a controls system used to control and automate all components, and the determination of all piping, valves, flow meters, actuators, pumps, and sensors to control the air flow.

The group will also determine external interfaces required for integration onto a vessel such as ISS, including electrical and mechanical attachment hookups, and human factors such as system operation, maintenance, and troubleshooting instructions.

4 Description of Final System

4.1 Requirements

All requirements for the system were outlined in the X-Hab Challenge Solicitation, and are summarized here:

Number	Requirement
L1:01	The system shall scrub Carbon Dioxide at 2650 ppm
L1:02	The system shall be closed loop to reduce the loss of resources
L1:03	The system shall incorporate the use of advanced sorbents for Carbon adsorption
L1:04	The system shall be scalable or use modularity to accompany crews of larger or smaller size
L1:05	The system shall remove a minimum of 4.16 kg/day of Carbon Dioxide at an ambient atmosphere maintained partial pressure CO ₂ of 2.0 mmHg based on a 760 mmHg total pressure. The ability to operate at lower than 2.0 mmHg is preferred.

4.2 Workflow Breakdown

The system has been broken down into five tractable subsystems, described below:

- Synthesis - Responsible for the synthesis and structural modifications of MOF material. As this MOF is advanced and little is known about its specific properties, this team will also conduct necessary tests on the MOF to determine its physical and mechanical properties.
- Process - This team will be responsible for the design and construction of the packed bed containing the MOF, air flow calculations through and around the packed bed(s), and piping required.
- Design - Responsible for the determination of components such as pumps and dehumidifiers to use, visualization of the process flow and CAD modeling of the system and components.
- Controls - Tasked with the writing and integration of automation software for controlling the system, wiring and hookup of all electrical components in the system, and creation of the GUI interface display.
- Systems Engineering - This team is responsible for the documentation of deliverables describing the system, such as the Concept of Operations, Verification and Validation Plans, and safety analysis.

5 Theory

5.1 Bed Depth Service Time

Bed depth and time for carbon dioxide adsorption have a positive linear relationship, as seen in the modified Bohart-Adams equation.

$$t = \frac{N_0}{C_0 V} x - \frac{1}{C_0 K} \ln\left(\frac{C_0}{C_B} - 1\right) \quad (1)$$

Where:

C_0 = Initial concentration of solute (mg/L)

C_B = Concentration of solute at breakthrough (mg/L)

K = Adsorption rate constant (L/mg*h)

N_0 = Adsorption capacity (mg/L)

x = Bed depth of column (cm)

V = Linear flow velocity (cm/h)

t = Time (h)

Trials can be conducted at various bed depths, with the corresponding service times recorded. Plotting bed depth (x) vs time (t) provides saturation lines, as seen in *Figure 1*.

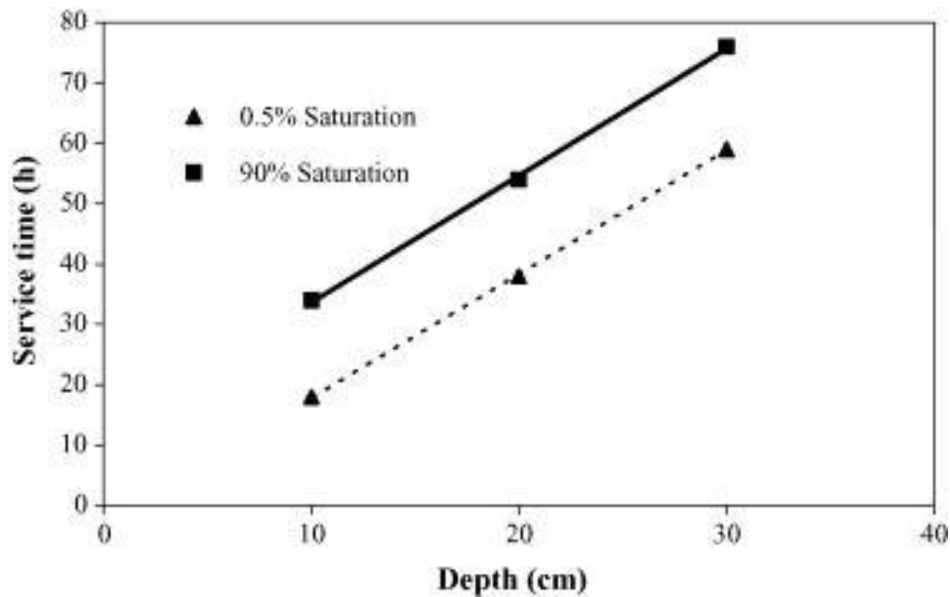

Figure: A positive linear relationship between bed depth and service time necessary to meet the saturation requirement [1].

The slopes (equation 2) and y-intercepts (equation 3) of these lines can now be used to calculate other model parameters.

$$a = slope = \frac{N_0}{C_0 V} x \# (2)$$

$$b = intercept = -\frac{1}{C_0 K} \ln\left(\frac{C_0}{C_B} - 1\right) \# (3)$$

The initial concentration of solute (C_0) will be known. In our case, it is 2,650 mg/L. Linear flow velocity (V) can be calculated based on our readings of the mass flow controller. Bed depth (x) and slope (a) will be known from the specific trial. Knowing all these variables, the adsorption capacity (N_0) can be determined from equation 2.

As stated previously, initial and final concentrations of solute (C_0 & C_B) will be known. In our case, we are trying to achieve 95% saturation, so the final concentration (after the bed) is 132.5 mg/L. The intercept will be known from the specific trial so the adsorption rate constant (K) can be determined from equation 3.

Finally, we can use these parameters with equation 4 to determine the minimum bed depth.

$$x_0 = \frac{V}{KN_0} \ln\left(\frac{C_0}{C_B} - 1\right) \# (4)$$

5.2 Gas Processors Suppliers Association (GPSA)

The GPSA Engineering Data Book also provides models for calculating the minimum bed depth. This method is cruder, as it does not directly use any data received from trialing the bed. However, it can be used to reconfirm the values obtained from the BDST method.

Mass transfer is assumed to be bulk diffusion limited. First, the superficial velocity can be estimated using equation 5.

$$V_{adjusted} = V_{max} \left(\frac{D_{minimum}}{D_{selected}}\right)^2 = \frac{4q}{\pi D_{selected}^2} \# (5)$$

Where:

- $V_{adjusted}$ = superficial velocity (cm/h)
- V_{max} = max superficial velocity (cm/h)
- $D_{minimum}$ = minimum bed diameter (cm)
- $D_{selected}$ = selected bed diameter (cm)
- q = volumetric flowrate (cm³/h)

Now, the length of mass transfer zone can be calculated using equation 6, where the mass transfer coefficient is taken from GPSA Engineering Data Book [2].

$$LMTZ = \left(\frac{V_{adjusted}}{35}\right)^{0.3} LMTZ_{coeff} \# (6)$$

The MOF stoichiometric bed length can be calculated using equation 7.

$$\text{MOF Stoich Bed Length} = \frac{m_{\text{MOF}} * A}{\rho_{\text{MOF}}} \# \quad (7)$$

Where:

$$\begin{aligned} m_{\text{MOF}} &= \text{mass of MOF (g)} \\ \rho_{\text{MOF}} &= \text{density of MOF (g/cm}^3\text{)} \\ A &= \text{cross-sectional area of bed (cm}^2\text{)} \end{aligned}$$

Finally, the total bed length can be estimated with equation 8

$$\begin{aligned} \text{Total Bed Length} \\ &= \text{Stoich Bed Length} + \text{LMTZ} + \text{Pellet Length} + \text{Unused Bed} \# \quad (8) \end{aligned}$$

5.3 Normalization of graphs

The CO₂ sensor that was used to read the concentration of CO₂ in the air stream leaving the packed bed was tremendously inaccurate. However the concentration readings were very precise. For this reason, the data collected by the sensor was normalized to the known inlet concentration of 2650 ppm. For instance, if after breakthrough the concentration was reading 2000 ppm, it would be assumed that the reading should actually be 2650 ppm. For this case, all concentrations collected by the sensor would be multiplied by 2650/2000. Before each test, the sensor was calibrated with a nitrogen stream to 0. This allowed us to normalize using only the maximum reading at the end of the test and not needing to account for inaccuracy with a zero-concentration reading. For this normalization it was assumed that the inaccuracies of the sensor were constant and a constant multiplier could be used for each data point. Further testing needs to be done to determine if this assumption was correct by using multiple gas sources with varying CO₂ concentrations.

5.4 Calculating CO₂ Capacity of Adsorbent

Data was output from the CO₂ sensor every three seconds. Once each data point was normalized due to inaccuracy from the sensor, the data points would be integrated to determine the total mmol of CO₂ absorbed. The steps below detail how this done.

First, the normalized concentration was converted from ppm to a mass density ($\frac{mg\ CO_2}{m^3}$). This is seen in the equation below.

$$massConc_{CO_2} = ppmConc_{CO_2} * 1.8 \frac{\frac{mg\ CO_2}{m^3}}{ppm}$$

Then, the mass density concentration, $massConc_{CO_2}$ ($\frac{mg\ CO_2}{m^3}$), would be used to determine the amount of CO2 absorbed, $CO_2\ adsorb$ ($\frac{mg\ CO_2}{m^3}$), at each data point. This subtracts the inlet concentration from the outlet to determine the amount of CO2 absorbed, $CO_2\ adsorb$ ($\frac{mg\ CO_2}{m^3}$), from the inlet air at each data point. This is seen in the equation below.

$$CO_2\ adsorb = 2650\ ppm * 1.8 \frac{\frac{mg\ CO_2}{m^3}}{ppm} - massConc_{CO_2}$$

Next, the amount of CO2 absorbed, $CO_2\ adsorb$ ($\frac{mg\ CO_2}{m^3}$), per data point was converted to total mmol of CO2 absorbed ($CO_2\ span$ (mmol)). This was found using the flow rate and time between data points (3 second span for our testing). The equation used is seen below.

$$CO_2\ span = CO_2\ adsorb * \dot{V} * 10^{-6} \frac{m^3}{mL} * \frac{1\ min}{60\ sec} * t_{DP} * \frac{1\ mmol}{44.01\ mg}$$

Where:

\dot{V} = Volumetric flow rate of air ($\frac{mL}{min}$)

t_{DP} = Time between data points (s)

Then, all the data points total CO2 absorbed were summed to find the total amount of CO2 absorbed, $CO_2\ total$ (mmol), over the whole test run. This equation is seen below.

$$CO_2\ total = \sum CO_2\ span$$

Lastly, the capacity of the absorbent was found by dividing the total amount of CO2 absorbed ($CO_2\ total$ (mmol)) by mass the adsorbent. This allows for a comparison of different absorbents when different masses for used for each tests. The equation for this is seen below.

$$Capacity = \frac{CO_2\ total\ (mmol)}{mass\ of\ adsorbent\ (g)}$$

The capacity should be in the units of mmol/g.

6 Baseline Design Solution

6.1 MOF Packed Bed

As the objective of this group revolves around the use of advanced sorbents, an in-depth look at the Metal Organics Frameworks (MOF) packed bed will be given.

The Synthesis team produced two MOF materials to be tested: Mg MOF-74 and Mg-MOG-BDC. The overall synthesis of MOF-74 is shown below. The structure of Mg-MOF-74 consists of magnesium ions connected with two molecules of 2,5 dihydroxy terephthalic acid. DMF, which is bound to the magnesium center is to be removed by heating the material to 250 C in vacuum. This will allow for an increased uptake of CO₂ from the sample. The procedure followed can be found in reference [8]. According to this report, the MOF was touted to have a CO₂ uptake up to 8.61 mmol/g obtained at 298 K and 1 bar.

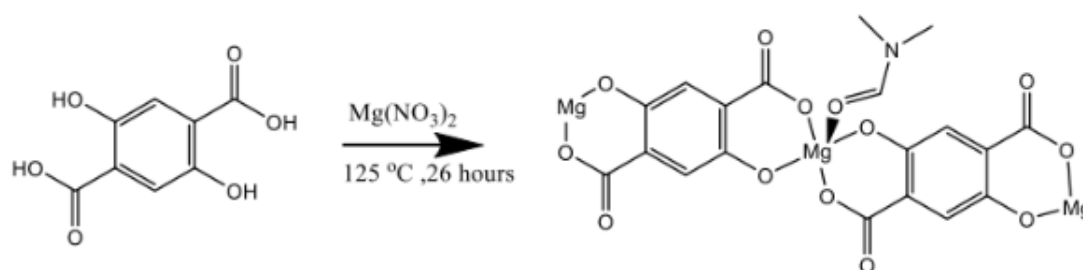
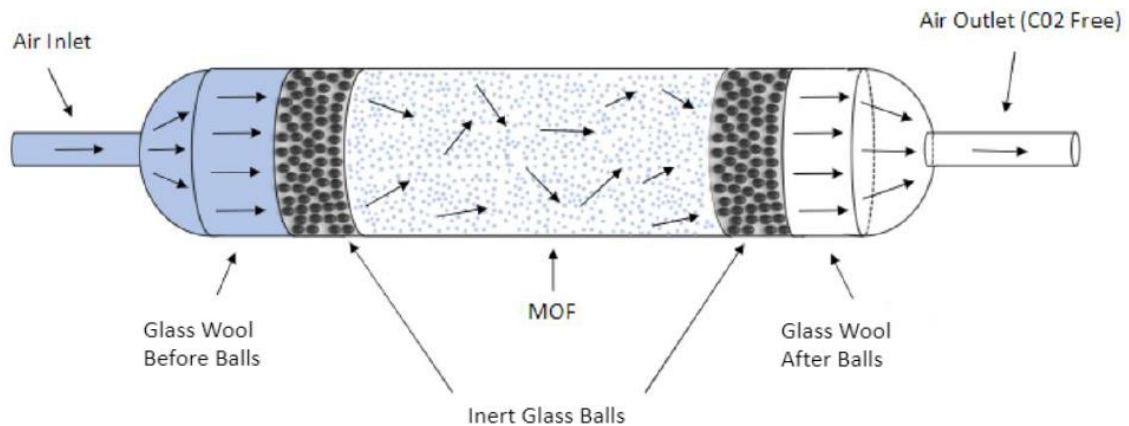

Figure SEQ Figure 1* ARABIC 3: Mg MOF-74 synthesis scheme

The second MOF produced is known as [Mg₄(bdc)₄(DEF)₄]_n, or Mg-MOF-BDC. The team followed the procedure described in reference [9]. This article reported CO₂ uptake at 1 bar is 0.9957 mmol/g.

The team used several techniques to characterize the MOFs produced. Techniques used to characterize MOFs were Powder X-Ray Diffraction (PXRD), BET and Chemisorption. A BET instrument was used for analyzing the material's surface area and pore sizes. CO₂ Chemisorption was used to test adsorption of the MOF. PXRD was used to analyze the crystallinity of the material. The goal in the synthesis, and possible modifications, is to

increase adsorption capacity, reduce regeneration conditions and maximize recyclability. The results of the PXRD and Chemisorption tests can be found in section 5. The process team decided that the optimal design for the packed beds would be to use randomly packed pelletized MOF. The MOF will be in pelletized form. The packed bed will be made of a light, inert metal. Using GPSA method, the size of the packed bed for the TRL-4 and TRL-6 designs can be estimated.



At the inlet and outlet of the MOF will be an area of inert ceramic balls, which will be used to keep the pelletized MOF in place and to create a more turbulent flow entering the MOF. Without an induced turbulent flow, the airflow remains laminar and passes through the MOF without achieving ideal levels of adsorption. Turbulent flow will allow the system to achieve maximum surface area contact between the flow and the MOF. Mesh support screens will be positioned at the start and end of the inert balls on both sides. Situated at the exit of the packed bed will be frits with a membrane size of around $0.2 \mu\text{m}$ to mitigate the release of MOF into the system.

6.2 TRL – 4

The system was built around a cylindrical packed bed. All gas was piped throughout the system using stainless steel piping. Two gas cylinders were present for the feed. One was a nitrogen cylinder used for purging the system. The other was an air cylinder with an elevated CO₂ concentration of 2650 ppm. This was the NASA provided CO₂ concentration that would be tested. These streams were then run through a desiccant, which would ensure the streams were free of water before entering the packed bed. Then the streams passed through a mass flow controller, purchased from Aalborg with flow rate capabilities of 0-100 mL/min. Then the stream would head towards the packed bed. Before the packed bed was an actuated two-way valve and a pressure gauge capable of reading -1 barg. The packed bed consisted of glass wool, used for holding things in place, glass beads, used as a filler, and MOF, which absorbed the CO₂. The packed bed would have an aluminum block placed around it, which would have heat tape, insulation tape, and a thermocouple with the aluminum block. This was used to heat the block during a desorption cycle. After the packed bed was another -1 barg pressure gauge and then a three-way actuated valve. This valve either went towards a vacuum pump or CO₂ sensor and vent. The piping towards the vacuum pump had a low flow valve in it. This was used to ensure the pull of the vacuum pump was not too much to pop the MOF or pull the materials of the packed bed out. The CO₂ sensor would allow for reading the CO₂ concentration of the outlet flow, allowing for an estimation of the amount of CO₂ absorbed on the MOF. A back-pressure regulator was placed after the sensor to allow for control over the internal pressure of the system, and then the stream was vented. As part of the plan for verification and validation of the system's functionality and ability to integrate, the group will build a test-bench setup that will be known as the TRL – 4 design. This setup will be the group's first opportunity to verify the validity of theoretical CFD models and lab tests of individual components and will identify bugs in the software system before constructing the final prototype.

For this setup, the concentration of CO₂ will be controlled through the use of highly pressurized CO₂ tanks with pre-determined concentrations. A mass flow controller will be used to control the mass flow into the packed beds. This setup will not require a secondary pump at the inlet of the system, as the pressurized gasses will do the work themselves. The N₂ tank will be used as a purge stream to completely clean off the MOF packed bed. The CO₂ sensor after the packed bed will be used to monitor the concentration of CO₂ and determine when the packed bed is saturated. This process will be relatively the same as the process used in the TRL-6 design, described in section 4.3. Figure 1 in section 2.2.1 shows a diagram of this setup. Below is another process flow diagram that shows the path of fluids in the setup.

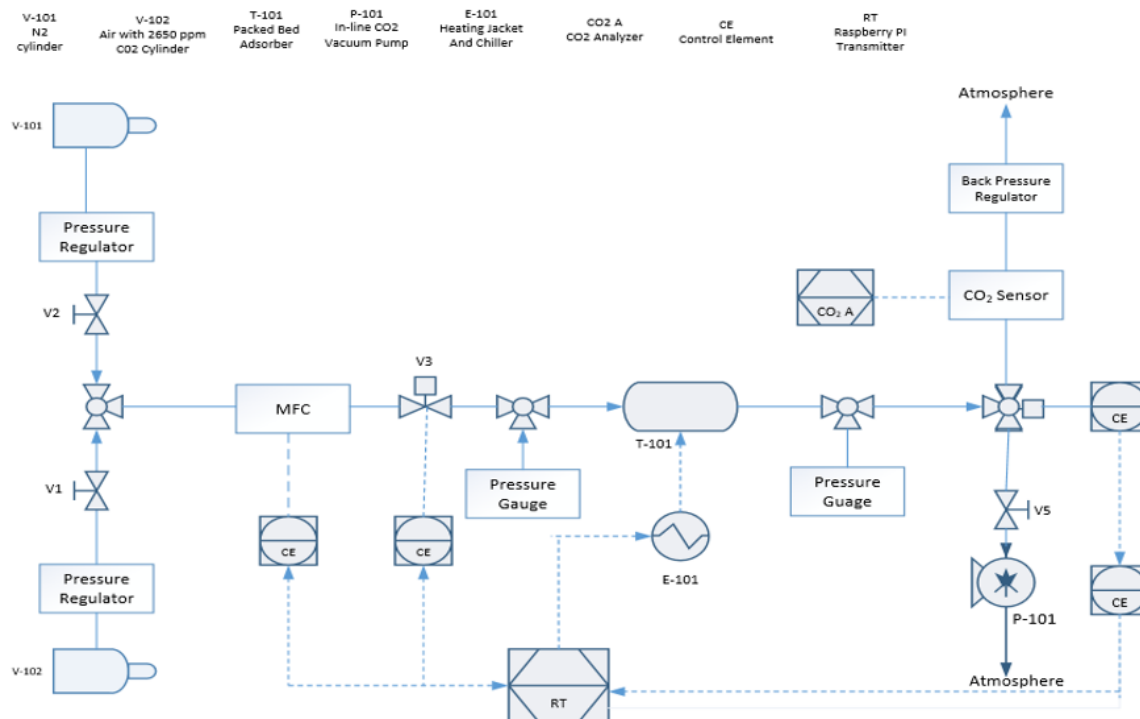

Figure 6.1: P&ID of TRL-4.

6.2.1 Desorption

The desorption stage began by closing the 2-way valve and changing the 3-way valve to the vacuum position. If the desorption test required heating, the Arduino set the heat tape to the desired temperature of 80C and time was taken for the heat tape to reach steady state at 80C. The vacuum pump was then turned on with the low flow valve at zero turns (highest valve coefficient) to ensure the system is not damaged. Then over a course of 26 minutes, the low flow valve was gradually opened according to Table 6.1. The flow coefficient corresponding to each turn can be found in Figure 6.2. During the vacuum step, the actual pressure of the packed bed is unknown because pressure gauges were used to roughly determine pressure. The vacuum pump used claims it can reach as low of a pressure of 20 microbar, however it is hypothesized that the low flow valve increased the pressure. After the 26 minutes the pressure gauge read -1 bar and the vacuum pump was turned off. At this point the desorption step was over unless a Nitrogen purge at 80C was required for the current test.

Table 6.1: Time and general corresponding pressure at each turn of the low flow valve.

Turns	0	1	2	3	4	5	6	7	8	9	Fully Open
Time (min)	1	1	5	2	1.5	1	1.5	1	1	1	10
Pressure Estimate (bar)	0	-0.05	-0.6	-0.8	-0.95	-0.98	-0.98	-0.99	-1	-1	-1

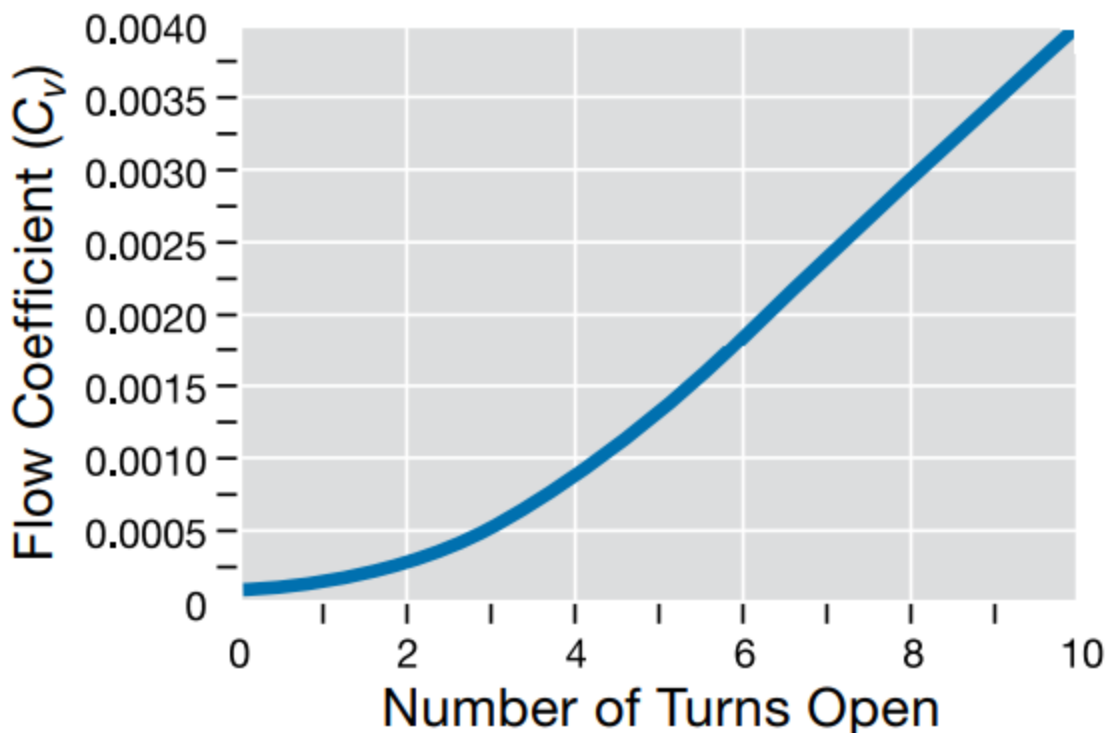

Figure 6.2: Flow coefficient corresponding to each turn of the low flow valve.

In order to prepare for the optional Nitrogen purge, pressure was gradually reintroduced into the system prior to exposing the packed bed to atmospheric pressure. This was done by creating a small leak in the system by loosening a nut on the 3-way fitting that connected the pressure gauge prior to the packed bed. Once the pressure gauges returned to atmospheric pressure, the 2-way valve was opened and the 3-way valve was changed to the vent. The nitrogen tank was opened, the mass flow controller was then turned on, and Nitrogen flowed through the system at 100mL/min at atmospheric pressure while the packed bed was at 80C. After 30 minutes, the mass flow controller was turned off, the nitrogen cylinder was closed, and the Nitrogen purge was over.

6.2.2 Adsorption

In order to set-up for adsorption, the nitrogen cylinder was opened and the CO2 sensor was calibrated by flowing Nitrogen through the sensor while bypassing the packed bed to get a 0 ppm reading. Once the CO2 sensor was calibrated, the nitrogen tank was closed. If desorption was conducted at 80C, the heat tape was turned off and the system was cooled to room temperature prior to starting adsorption. Cooling time was decreased by removing the insulation tape, heat tape, and heat block. If a nitrogen purge was not ran, pressure needed to be gradually reintroduced into the system prior to exposing the packed bed to atmospheric pressure. This was done by creating a small leak in the system by loosening a nut on the 3-way fitting that connected the pressure gauge prior to the packed bed. Once the pressure gauges returned to atmospheric

pressure, the 2-way valve was opened and the 3-way valve was changed to the vent. Once the packed bed was returned to room temperature, the adsorption stage was ready to begin. The air cylinder was opened, the mass flow controller was turned on, and air containing 2650 ppm of CO₂ at 100 mL/min was passed through the system. During adsorption the CO₂ sensor continuously outputted the CO₂ concentration of the outlet stream to the vent. Once the CO₂ sensor reached steady-state (breakthrough), the adsorption step was over, the air cylinder was closed, and the mass flow controller was turned off. The CO₂ sensor would not reach 2650 ppm of CO₂ due to error of the sensor.

6.3 TRL – 6

The system has two well-defined stages in its process: the adsorption stage and desorption stage. The description of the system will be divided into these two parts for clarity. The image below shows the system and clearly labels where these stages begin and end.

System Level Schematic View [TRL ~6]

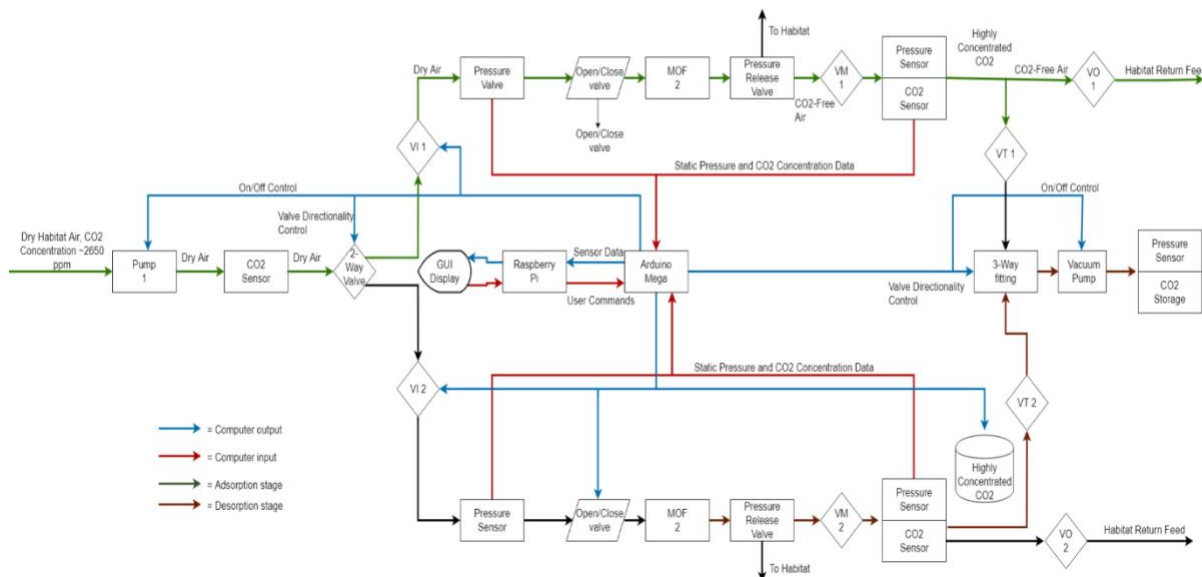

6.2.1 Adsorption

The adsorption stage begins with an air compressor sucking habitat air into the inlet of the system. To ensure that the air within the habitat, taken to be 600 m³, is adequately filtered, the pump will need to displace 50 L/min of air. The air will pass through a sensor that monitors and relays initial CO₂ concentration of air coming in to the system's computer. The flow will then pass through a 3-way valve that will direct the flow towards the MOF packed bed that is freshly desorbed. A pressure sensor will be used to monitor the flow speed and static pressure within the piping just before entering the

MOF packed bed to ensure that the pressure isn't high enough to damage piping or the packed bed. As discussed before, the MOF packed bed will selectively adsorb CO₂, while allowing oxygen to pass through. A secondary CO₂ sensor after the packed bed will monitor the CO₂ concentration of air after passing through the packed bed. As shown in the test data in section 5, when the bed is freshly desorbed the MOF is very efficient at adsorbing CO₂ until total mass gain possible by the MOF is around 80%. The concentration read by this sensor should be at or near 0% until the MOF is packed beyond this 80% threshold, at which point the CO₂ concentration after that packed bed will begin to raise to values closer and closer to the pre-bed concentration. The system computer will take the difference between these two concentration data, and at a concentration point (that will be determined through the TRL-4 setup) the packed bed will be defined as saturated begin desorption. Until this point, the stream will remain



open and the O₂ will be free to pass through the next three-way valve junction. This valve will direct the flow towards the outlet of the system, which returns the O₂ to the habitat. The software architecture for this process and the desorption process is shown below.

6.2.2 Desorption

As stated above, once the MOF is determined to be saturated, the desorption stage for this packed bed will begin. The first three-way valve will divert the flow from the habitat to the other branch of the system, and the open/close valve just before the packed bed will be switched closed. The three-way valve at the next junction will then be switched to divert the flow towards the vacuum pump, which will be turned on and begin sucking CO₂ from the piping and into the storage vessel. As CO₂ is sucked out of the piping, the pressure will begin to lower within the packed bed and the piping connecting it to the pump. This pressure differential between the pump and the packed bed will cause CO₂ to begin to desorb from the MOF. The group will use the data collected by the CO₂ sensor after the packed bed along with desorption timing data collected in the TRL-4 setup to determine how and when that packed bed is deemed fully desorbed. Once this occurs, the diaphragm pump will be switched off. Once the packed bed on the other branch of the system is deemed saturated through the process described in the previous

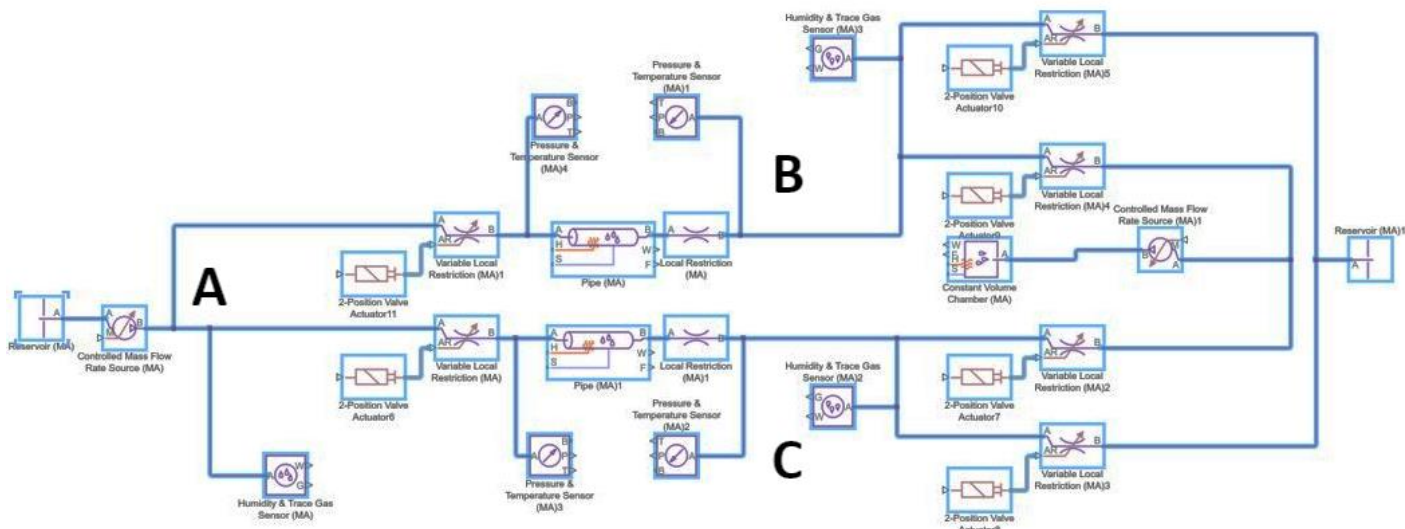

section, valves will again switch directionality and the newly desaturated MOF will begin desorption. The two packed beds will alternate in this fashion through the lifecycle of the system, with one packed bed always being adsorbed while the other is being desorbed.

7 Performed Design Analyses

7.1 MOF Chemisorption

7.1.1 Testing Procedure

The uptake capacity, kinetics and binding strength of CO₂ on the MOFs will be characterized by an array of techniques to understand and optimize the conditions for its capture and release.

Measurement of the MOF's CO₂ Langmuir sorption isotherms at 273 K will provide information on the maximum adsorption capacity of the material. Collection of equilibrium adsorption data at different partial pressures of pure CO₂ will provide an initial estimate of the percent saturation achievable at the target 2650 ppm under static conditions. Collection of the corresponding desorption branch under vacuum will provide information on the viability of a low-pressure swing approach. The equilibrium values obtained from the batch isotherm measurements will inform the conditions to use for dynamic adsorption measurements.

Dynamic adsorption will be initially tested in CO₂/He mixtures at different partial pressures in a chemisorption flow reactor equipped with a thermal conductivity detector. Initial experiments will consist of pulsed chemisorption of a 10% CO₂/He mixture at 273 and 298 K. Saturation values under these dynamic conditions will be compared to batch isotherm data at 0.1 bar. Uptake kinetics will then be evaluated by repeating pulsed chemisorption at different flow rates in the range of 10 to 50 cm³/min

A temperature programmed reaction (TPR) experiment with 10% CO₂/He from 250 to 373 K will be performed to distinguish conditions for physisorption via metal coordination from amine-mediated chemisorption. Cross-examination of samples treated at temperatures below and above TPR peak via infrared spectroscopy will be used to further elucidate the type of CO₂-MOF bonding. Repeating the experiment at different flow rates will provide activation parameters for chemisorption. Temperature programmed desorption (TPD) experiments will then be performed with samples pretreated below and above the TPR peaks to determine the energy requirements for MOF regeneration. The results obtained from these experiments will be contrasted with data obtained from thermogravimetric analysis (TGA) under variable atmospheres. Specifically, TGA experiments will be run by thermally pretreating MOF samples under N₂, followed by cooling down to ambient temperature and timed exposure of the cooled samples to CO₂ while monitoring mass gain. The CO₂ loaded MOFs will then be set again in N₂ atmosphere and the temperature will be ramped at a low rate to monitor desorption via changes in the mass of the sample. The combined results will be used to determine the energy requirements for CO₂ desorption and inform the choice for a pressure-only or a combination of temperature/pressure swing system.

8 Results and Discussion

8.1 MOF Testing

All MOFs were pelletized before the testing to have a size of 1 – 1.7 mm. The first series of tests with the testing apparatus (Figure 6.1) was to find the breakthrough times and adsorption capacities of the MOF modifications (N,N' Dimethylethylenediamine and Ethylenediamine) with optimal desorption conditions. This was done by running desorption followed by adsorption for both MOF modifications. The desorption step consisted of two steps. The step pulled a vacuum for 26 minutes at 80C. After the vacuum step, a second step passed Nitrogen through the packed bed at 100 mL/min at 80C for 30 minutes to remove any residual CO₂ from the MOF. After the desorption steps, the adsorption step was ran. For both modifications, air containing 2650 ppm was passed through the system at 100 mL/min at atmospheric pressure. Figure 8.1 displays the breakthrough curves for both MOF modifications.

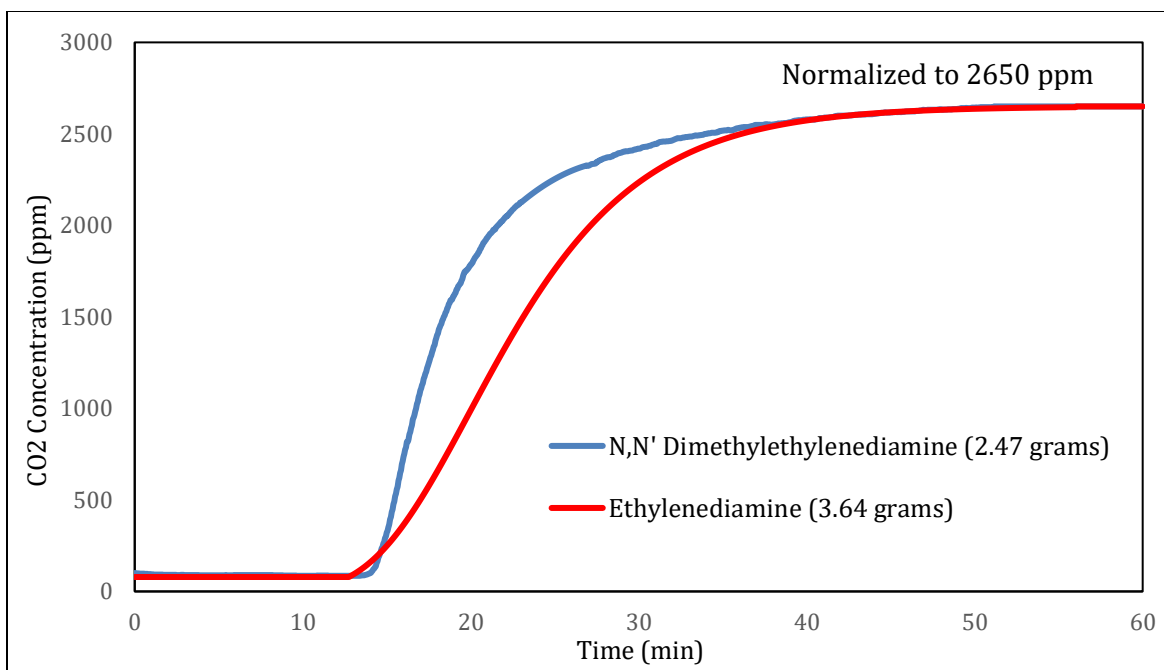

Figure 8.1: Breakthrough curves for MOF modifications at 100mL/min of air with 2650ppm of CO₂

The breakthrough curves in Figure 8.1 were used to determine breakthrough times and which MOF modification had the highest adsorption capacity. Due to error in the CO₂ sensor, the breakthrough curves in were normalized to 2650 ppm. The time until breakthrough is very similar at ~50 minutes for both MOF modifications under the optimal desorption conditions. It was found that the 2.47 grams of N,N' Dimethylethylenediamine had an adsorption capacity of .141 mmol/g and the 3.64 grams of Ethylenediamine had an adsorption capacity of .107 mmol/g. Therefore N,N' Dimethylethylenediamine had a higher adsorption capacity of the MOF modifications after the optimal desorption conditions.

N,N' Dimethylethylenediamine was tested with two less optimal desorption methods to observe the effect on adsorption capacity. Each test was conducted by running the desorption step following by an adsorption step. For the first test, the first less optimal desorption step pulled a vacuum for 26 minutes at room temperature. For the adsorption step, air containing 2650 ppm was passed through the system at 100 mL/min at atmospheric pressure. For the second test, the second less optimal desorption method consisted of pulling a vacuum for 26 minutes at 80C. For the adsorption step, air containing 2650 ppm was passed through the system at 100 mL/min at atmospheric pressure. The breakthrough curves for each test were plotted in Figure 8.2 with the breakthrough curve from Figure 8.1 that underwent the optimal desorption with the same adsorption conditions.

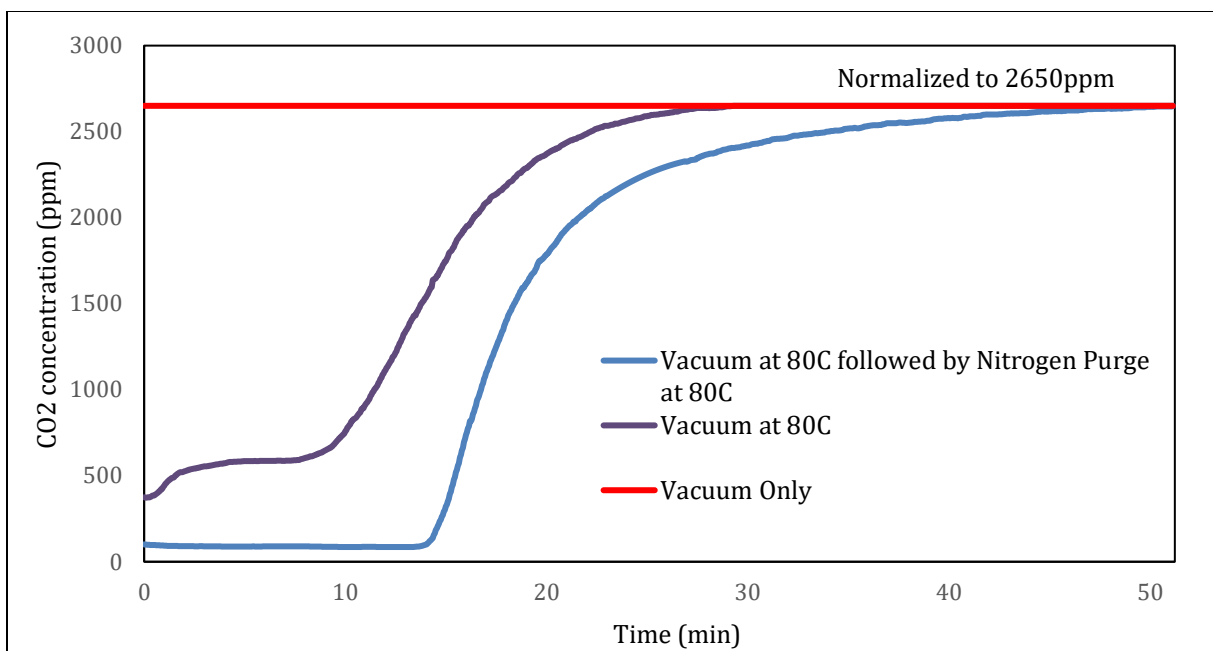

Figure 8.2: Breakthrough curves for N,N' Dimethylethylenediamine at 100mL/min of air with 2650ppm of CO2 with different desorption conditions.

The breakthrough curves in Figure 8.2 were used to determine how less optimal desorption conditions affect the adsorption capacity of N,N' Dimethylethylenediamine. Due to error in the CO2 sensor, the breakthrough curves in were normalized to 2650 ppm. N,N' Dimethylethylenediamine did not adsorb following vacuum desorption step at room temperature. Although N,N' Dimethylethylenediamine did adsorb following the vacuum desorption step at an elevated temperature of 80C with a breakthrough time of ~30 minutes and an adsorption capacity of 0.083 mmol/g. When compared to N,N' Dimethylethylenediamine with optimal desorption conditions (Vacuum at 80C followed by Nitrogen purge at 80C), N,N' Dimethylethylenediamine with vacuum at 80C reached breakthrough ~20 minutes faster and the adsorption capacity of 0.083 mmol/g was 59% of .141 mmol/g. Therefore with the 26 minute vacuum step used for this testing, N,N' Dimethylethylenediamine required a slightly elevated temperature of 80C to experience desorption.

After observing the results from N,N' Dimethylethylenediamine, the chemical team hypothesized that the chemical bonds between the CO2 and amine groups were too strong for a vacuum only desorption. Based on that, Ethylenediamine was tested with a vacuum desorption at room temperature. The test was conducted by running the desorption step following by an adsorption step. The desorption step pulled a vacuum for 26 minutes at room temperature. For the adsorption step, air containing 2650 ppm was passed through the system at 100 mL/min at atmospheric pressure. The breakthrough curve for the test is displayed in Figure 8.3.

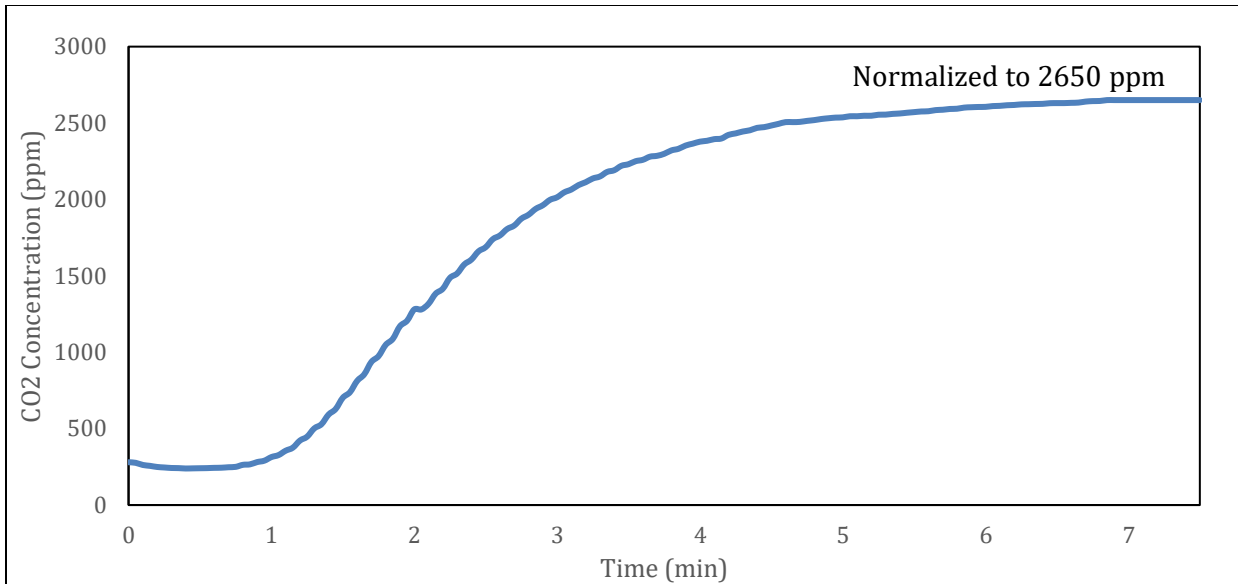

Figure 8.3: Breakthrough curves for Ethylenediamine at 100mL/min of air with 2650ppm of CO₂ following a desorption step of vacuum at room temperature.

The breakthrough curve in Figure 8.3 displayed that Ethylenediamine did adsorb CO₂ after being desorbed with the vacuum at room temperature. The breakthrough time was ~6 minutes and the adsorption capacity was 0.012 mmol/g. When compared to Ethylenediamine with optimal desorption conditions (Vacuum at 80C followed by Nitrogen purge at 80C) from Figure 8.1, Ethylenediamine with vacuum at room temperature reached breakthrough ~44 minutes faster and the adsorption capacity of 0.012 mmol/g was 11% of 0.107 mmol/g. Therefore Ethylenediamine did adsorb a small amount of CO₂ following the desorption step running the vacuum pump of 26 minutes at room temperature.

8.2 4A Zeolite Testing

One test was run with the 4A Zeolite as a proof of concept for the TRL-4 test bench. First the zeolite was heated up to 200C for 2 hours while 100 mL/min of Nitrogen flowed over it. This was done to desorb any CO₂ or water on the surface. The zeolite was then cooled to room temperature prior to adsorption. The adsorption step was ran by flowing air with 2560 ppm of CO₂ at 59 mL/min at ambient pressure. The breakthrough curve is displayed in Figure 8.4.

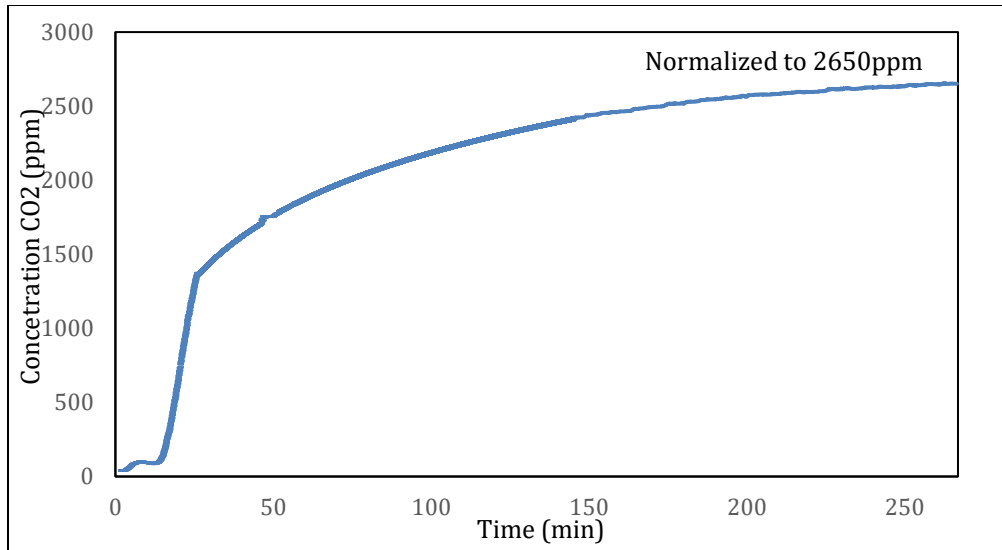

Figure 8.4: Breakthrough curve for 4A Zeolite at 59 mL/min of air containing 2650 ppm following a desorption step of flowing nitrogen for 2 hours at 100 mL/min at 200C.

Throughout periods of time during adsorption there was a problem with the CO₂ sensor where the sensor was not gathering data. In Figure 8.4, areas where the sensor did not gather data were interpolated. The adsorption capacity of the 4A Zeolite was found to be .194 mmol/g. This adsorption capacity was compared to an isotherm found in literature shown in Figure 8.5.

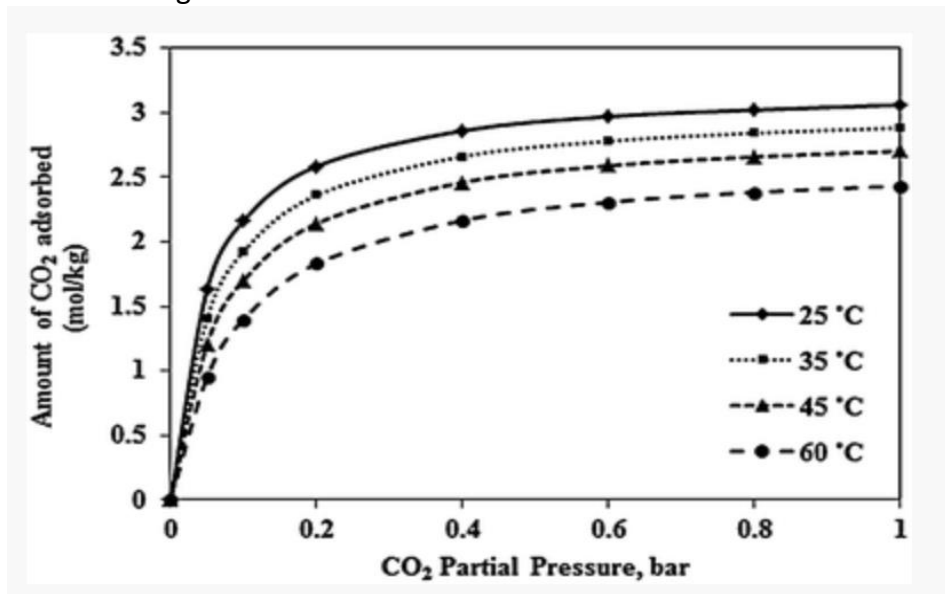

Figure 8.5: Literature isotherm for 4A Zeolite.

Using this figure and the Langmuir isotherm equation, the predicted capacity is 0.057 mmol/g for the CO₂ partial pressure of 2650 ppm that our system operates at. This is about four times lower than what was found during our absorption study but it did show that our TRL-4 test bench is capable of desorbing and adsorbing.

8.3 MOF PXRD Analysis

As stated before, PXRD was used to analyze the crystallinity of the MOFs produced. The results of this analysis are shown below.

The peaks of the Mg-MOF-BPDC did not match the one recorded in literature [2]. The unexpected broad peak at 25° could correlate to a collapse microstructure, leading us to believe that the MOF framework did not form. This could have been due to either an incorrect stoichiometric ratio of reactants during synthesis or not properly washing and evacuating all solvent out post-synthesis. This would mean that the synthesized MOF would not have the correct amount of surface area to adsorb CO₂. Other corresponding peaks like the ones seen at 18 and 22 could correspond to the individual components of Mg-MOF-BPDC (Magnesium Nitrate or the organic linker Terephthalic Acid).

The peaks of Mg-MOF-74 did correlate to the one that was found in literature [1]. As seen above in figure 4c, the major peak of 12° was prevalent in both. Since there are only sharp peaks and no broad peaks, it conveys that the molecular structure is open and porous. The two other peaks around 30 and 33 also correlate to the observed ones in literature. This gives convincing evidence that our sample Mg-MOF-74 was correctly synthesized and purified.

8.3.1 Thermogravimetric Analysis

TGA is used to test the mass of the sample over time in response to temperature changes. The first part of the TGA test was to fully evacuate the MOF. This was done by slowly increasing the temperature over time under inert atmosphere (nitrogen). This step is shown as a blue line on the graph. The sample was cooled slowly to room temperature under the inert nitrogen. This step is illustrated with a green line. Once room temperature was reached, the MOF was exposed to CO₂. To estimate the adsorption of CO₂ at 2650ppm two different partial pressures were tested. This step is illustrated with an orange line. Once the maximum capacity was reached, determined when there was no change in weight, the sample was heated up slowly. This desorption cycle is represented as a red line in figure 4.

Based on the adsorption uptake, Mg-MOF-74 took up 3.72% of its weight in CO₂. Another trial was done and its purge was instead ramped up to 300 °C. The adsorption uptake for this trial was 5.6% (1.27mmol/g). of its weight in CO₂. This illustrates that the first trial did not fully purge the MOF before the adsorption step. The other MOF did not appear to have any major uptake capacity for CO₂ since the capacity was measured to be under 0.3% of its weight in CO₂.

The adsorption step took 12 minutes for Mg-MOF-74 to reach its maximum capacity while it took Mg-MOF-BDC just under 2 minutes.

8.3.2 ASC Report

ABSTRACT: Metal Organic Frameworks can efficiently adsorb CO₂ gas. This is due to their high surface areas, pore sizes and adjustable internal surface properties. Particularly, magnesium-based MOFs such as Mg-MOF-74¹ and Mg-MOF-BPDC² have open, Lewis acidic coordination sites that can bind CO₂. Since these binding sites have low binding energy, CO₂ can readily be desorbed and cycled. In many applications of these CO₂ is adsorbed at high partial pressures and the MOF is thermally regenerated. Contrary, we are interested in developing a system that can selectively adsorb CO₂ at sub 3000 ppm levels and desorb using a pressure swing. In this study three different amine groups were functionalized onto the base Mg-MOF-74 structure and tested for long-term pressure cycling. The MOFs were characterized by Powder X-Ray Diffraction, N₂ sorption isotherms, and thermogravimetric analysis. Results show that after input of CO₂ stream into our sample gain around 10% of its weight.

INTRODUCTION

MOF stands for metal-organic framework. They consist of multiple organic ligands bonded together by metal clusters. Since these metals can form complex orientations with the organic ligands, they result in many different types of 3D structures. The main reason why MOFs are promising for CO₂ capture is the fact that they can create highly porous structures with large adsorption surfaces. This study focuses on magnesium-based MOFs: Mg-MOF-74¹ and Mg-MOF-BDC². The structure of Mg-MOF-74 can be seen in **figure 1a**. It consists of a magnesium metal ion connected to two molecules of 2,5 dihydroxy terephthalic acid. Each Magnesium metal is connected to 4 oxygen atoms. Dimethyl formamide (DMF) solvent is also bound to the magnesium center; however, this is removed by heating the material at 250 °C in vacuum overnight. This will result in an open coordination site on the magnesium centers. The open site allows uptake of CO₂ through a dipole-quadrupole

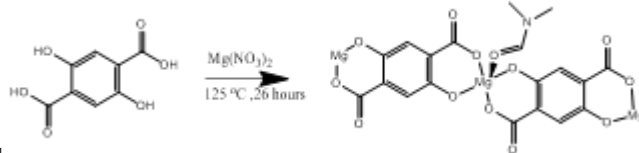

interaction.¹

Figure 1a: Synthesis Scheme of Mg-MOF-74 (showing coordination mode of magnesium)

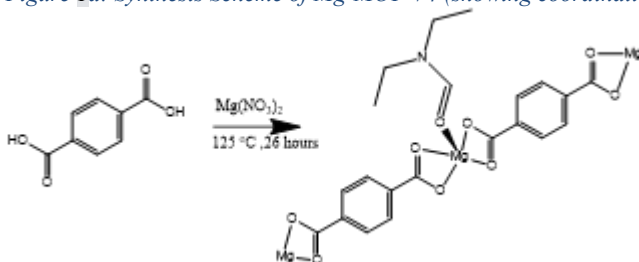

Figure 1b: Synthesis Scheme of Mg-MOF-BDC (showing coordination mode of magnesium)

The single-crystal structural analyses of Mg-MOF-BDC² reveal that the benzenedicarboxylic dianion connects two dinuclear units of a Mg(II) ion that is tetra-coordinated to four bridging oxygen atoms and a Mg(II) ion that is hexa-coordinated to four bridging oxygen atoms, and two pendant diethyl formamide (DEF) molecules, to form a tetranuclear unit. These special arrangements result in novel zig-zag patterned 1-D rhombic channels containing coordinated DEF molecules. Similar to Mg-MOF-74, Mg-BDC-MOF can result in unsaturated metal centers by heating it at 400 °C under nitrogen flow overnight. This unsaturation has been shown to improve CO₂ adsorption of this material.

Figure 2: From left to right ethylenediamine, N,N'-dimethylethylenediamine and N-methylethylenediamine

The goal of this study is to find an efficient system to remove 2650 ppm CO₂ from a closed system atmosphere. The two MOFs mentioned were chosen due to their inexpensive synthesis and high CO₂ adsorption capacity. Since adsorption of CO₂ at low concentrations requires a higher binding energy, we have chosen to functionalize Mg-MOF-74 with three different amine groups. These amine groups bind to the open metal sites of the MOF and create additional strong binding sites for CO₂. There is an optimal number of functionalized groups to graft onto the structure since too many will cause pore congestion and will limit the mass transfer through the structure. The three amine groups involved in this study are ethylenediamine, N,N'-dimethylethylenediamine and N-methylethylenediamine.

As seen in **figure 2**, all three amine groups have different nitrogen configurations (either as primary or secondary). By their nature, secondary amine groups will be more basic than primary groups and will have a higher binding affinity. The higher affinity binding site will interact with the magnesium metal of the MOF, leaving the other amine group on the other side to interact with the CO₂ molecule. Since secondary amine groups will have stronger dipole interactions with CO₂, we expect them

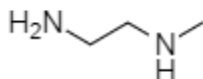
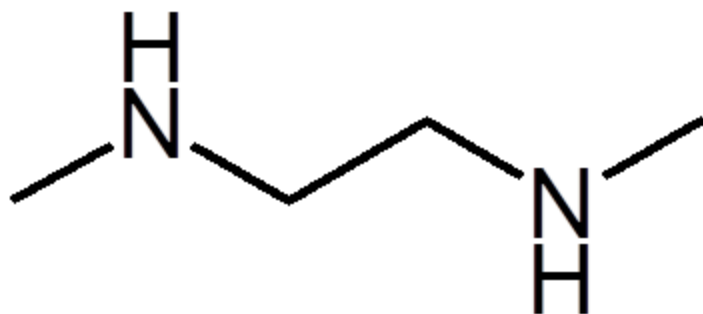

to have higher CO₂ binding strength. However, since secondary amine groups are more sterically hindering, we expect them to decrease the effective pore diameter of the particle. The primary amine groups might not have as strong of binding interactions as the secondary amine groups; however, they are inherently smaller in size and will reduce the steric hindrance of the active sites for adsorption.

All three of these functionalized MOFs will undergo multiple pressure swing cycles to determine long-term stability. The goal of this study is to increase adsorption capacity, minimize energy cost, reduce regeneration conditions and maximize recyclability.

EXPERIMENTAL

Materials

Component	Vendor
<i>2,5-dihydroxyterephthalic acid</i>	Fisher Chemical
<i>Magnesium Nitrate hexahydrate</i>	Fischer Chemical
<i>Dimethylformamide</i>	Fischer Chemical

Table 1a: Compounds for synthesis of Mg-MOF-74

Component	Vendor
<i>Ethylenediamine</i>	Fisher Chemical
<i>N,N-Dimethylethylenediamine</i>	Sigma Aldrich
<i>N-Methylenediamine</i>	Sigma Aldrich

Table 1b: Modification compounds for Mg-MOF-74

Component	Vendor
<i>Terephthalic Acid</i>	Sigma Aldrich
<i>Magnesium Nitrate hexahydrate</i>	Fischer Chemical
<i>Diethylformamide</i>	Sigma Aldrich

Table 1c: Compounds for synthesis of Mg-MOF-BDC

Synthesis of Mg-MOF-74³

The synthesis was done according to reported literature.³ In a solution of 270 mL of dimethylformamide, 18 mL of ethanol, and 18 mL of water, 2,5-dihydroxyterephthalic acid (0.674g, 3.40mmol) and Mg(NO₃)₂·6H₂O (2.8g, 10.9mmol) were dissolved with sonication. The resulting stock solution was decanted into fifteen 20 mL vials, which were capped tightly and heated at 125 °C for 26 h. Multiple vials were used to maximize surface area, since the smaller vials had more contact with the solution. The increase of surface area for crystallization to occur thereby increased the final yield. The mother liquor was

then decanted; the products washed with methanol. They were then immersed in methanol and allowed to sit overnight. The products were combined and exchanged into fresh methanol daily for 4 days. They were then evacuated to dryness and heated under vacuum at 250 °C for 6 hrs to remove any extra solvent and activate the binding sites. An alternative method for removing solvent was also tested by evacuating

Modification of Mg-MOF-74

Three different amine groups were attached onto the synthesized Mg-MOF-74. The different amines that were studied: Ethylenediamine, N,N' Dimethylethylenediamine and N-Methylethylenediamine. The synthesis of the modified Mg-MOF-74 followed a similar procedure of that reported in literature^[4]. All three amine groups were grafted onto the Mg-MOF-74 structure by adding them under reflux with toluene. 2.00g of each amine group to 0.5g of Mg-MOF-74. This provides a 2:1 mmol ratio of amine group to metal active site. This was mixed with 100 mL of anhydrous toluene for a 12-hour reflux.

Pelletization

The Carver Auto Pellet Press Model 3887NE.L was used to pelletize both MOFs. Each MOF and the three amine modified MOFs were packed into the press under wet solvent conditions. This required 1 to 2 drops of methanol to wet the MOF. The wetted MOF was then compressed for 1 minute under 300bar pressure. The following disk broken up and sieved to a mesh size of 12-18 (1-1.7mm). This is then recovered and activated under vacuum and 120C for 20 hours.

Synthesis of Mg-MOF-BDC

A mixture of 1,4-benzenedicarboxylic acid (400 mg, 2.41 mmol) and Mg(NO₃)₂ · H₂O (616 mg, 2.4 mmol) in 12 ml N,N-diethylformamide (DEF) was heated to 120°C into 10 (5 ml) screw top glass bottle for 18 h. The mixture was cooled to room temperature, and the resulting crystals were filtered from the reaction mixture and washed with DEF. Next step was prepared by heating mixture at 400 °C for 30 min in a tube furnace under a nitrogen atmosphere. It was assumed that all four DEF molecules are removed at 400 °C. No amine modification was done for this MOF.

Page Break

Apparatus of Pressure Swing CO₂ Scrubber/Testing Methods

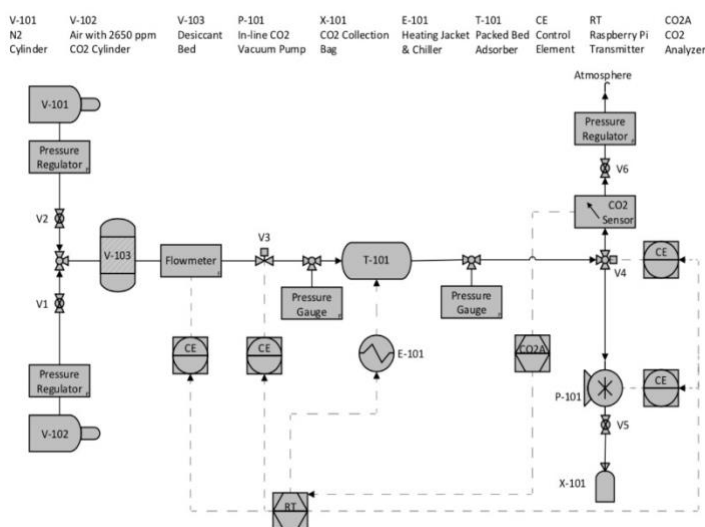

Figure 3 displays the P&ID of the CO₂ scrubber apparatus. Air with 2650 ppm or pure N₂ can be fed into the system. It passes by a mass flow controller, desiccant bed, control valve, and pressure gauge before entering the packed bed. The packed bed is wrapped in heat tape and has a thermocouple placed in it, which can supply heat and read temperature during desorption. Immediately after the bed is another pressure gauge, which can be used to analyze pressure drop across the bed. Then, a CO₂ sensor is used to determine when the MOF (in the packed bed) is saturated. From there, the process air can either be vented to the atmosphere or vacuum can be pulled for desorption. Control elements are present on the mass flow controller, control valves, CO₂ sensor, and vacuum pump. Data transmitted from the CO₂ sensor is used in a feedback loop with the raspberry-pi controller. This is used to control the vacuum pump, flowmeter, thermocouple, heat tape, and valve positions.

FIG 4b: TGA of Mg-MOF-BDC

Figure 3: P&ID of CO₂ Scrubber

Before operating the CO₂ scrubber apparatus, it was ensured that all valves were closed. Then, the air gas cylinder was opened, in order to pressurize the system. The mass flow controller (MFC) was ensured to be operational and then valve 1 (V1), which allows air flow to the MFC, was opened. Next, V3 and V6 were opened, along with

changing V4 (three-way valve) to flow to the vent. V2 and V5 remain closed. The pressure regulator was adjusted on the air gas cylinder and back-pressure regulator near the vent until the desired packed bed pressure was obtained. Then, the CO₂ sensor was turned on. Before running tests, the CO₂ sensor needs to be calibrated with N₂ and the 2650 ppm air. The N₂ is used to calibrate it to 0 and the 2650 is for normalization. It was found that the accuracy of the CO₂ sensor was poor, so a normalization factor was needed to be used for all results. Finally, the MFC was set to the desired flowrate was set. At this point, everything was set-up and the experiment was ready to begin. Air flowed through the system (at a steady rate), until the MOF was saturated with CO₂. The CO₂ sensor continually increased in concentration until reaching 2650 ppm again, which indicated saturation. Pressure gauges were continually monitored throughout the process. Once saturation had occurred, the desorption process began. This involved pulling vacuum on the test bed. First, the MFC was turned from flow to closed. Then V1 was closed, stopping any air from flowing into the system. Then, V3 and V6 were closed. Closing V3 ensured the MFC didn't have vacuum pulled on it. Closing V6 confirmed that the vacuum pump does not pull in air from the atmosphere. Afterwards, V4 was changed from vent to vacuum. Finally, the pump was turned on until the CO₂ was fully desorbed. The pump was ran for 30 minutes, with a pressure decrease rate of 0.5 psi/minute. This was controlled using a low flow valve. One "turn" was done on the valve every time a steady state pressure had been reached. Once the desorption was done, the three-way valve should be cracked open. This was done by providing 5 volts, rather than 24 volts, which caused it to open very slowly.

Several trials were conducted, so a nitrogen purge was required in between each run. To do this, the vacuum pump was turned off. Then, V3 and V6 were opened. V5 was closed and V4 was changed from vacuum to vent, allowing the system to return to atmospheric pressure. Then, the gas cylinder was closed, followed by the closing of V1. Next, V2 was opened before the nitrogen gas cylinder was opened. The system was purged for 10 minutes before turning off the nitrogen gas cylinder.

FIG 4b: TGA of Mg-MOF-BDC

RESULTS

Thermogravimetric Analysis (TGA)

As seen in **figure 5**, the TGA graphs for both types of Mg-MOF are illustrated. TGA is used to test the mass of the sample over time in response to temperature changes. The first part of the TGA test was to fully evacuate the MOF. This was done by slowly increasing the temperature over time under inert atmosphere (nitrogen). This step is shown as a blue line on the graph. The sample was cooled slowly to room temperature under the inert nitrogen. This step is illustrated with a green line. Once room temperature was reached, the MOF was exposed to CO₂. To estimate the adsorption of CO₂ at 2650ppm two different partial pressures were tested. This step is illustrated with an orange line. Once the maximum capacity was reached, determined when there was no change in weight, the sample was heated up slowly. This desorption cycle is represented as a red line in figure 4.

Based on the adsorption uptake, Mg-MOF-74 took up 3.72% of its weight in CO₂. Another trial was done and its purge was instead ramped up to 300 °C. The adsorption uptake for this trial was 5.6% (1.27mmol/g). of its weight in CO₂. This illustrates that the first trial did not fully purge the MOF before the adsorption step. The other MOF did not appear to have any major uptake capacity for CO₂ since the capacity was measured to be under 0.3% of its weight in CO₂.

The adsorption step took 12 minutes for Mg-MOF-74 to reach its maximum capacity while it took Mg-MOF-BDC just under 2 minutes.

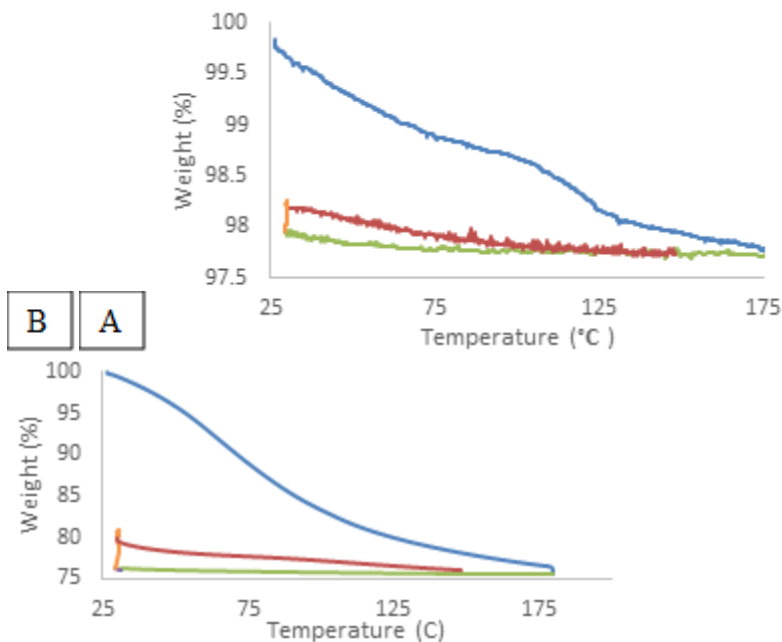

Figure 5: a) TGA of Mg-MOF-74 b) TGA of Mg-MOF-BC
Powder X-Ray Diffraction (PXRD)

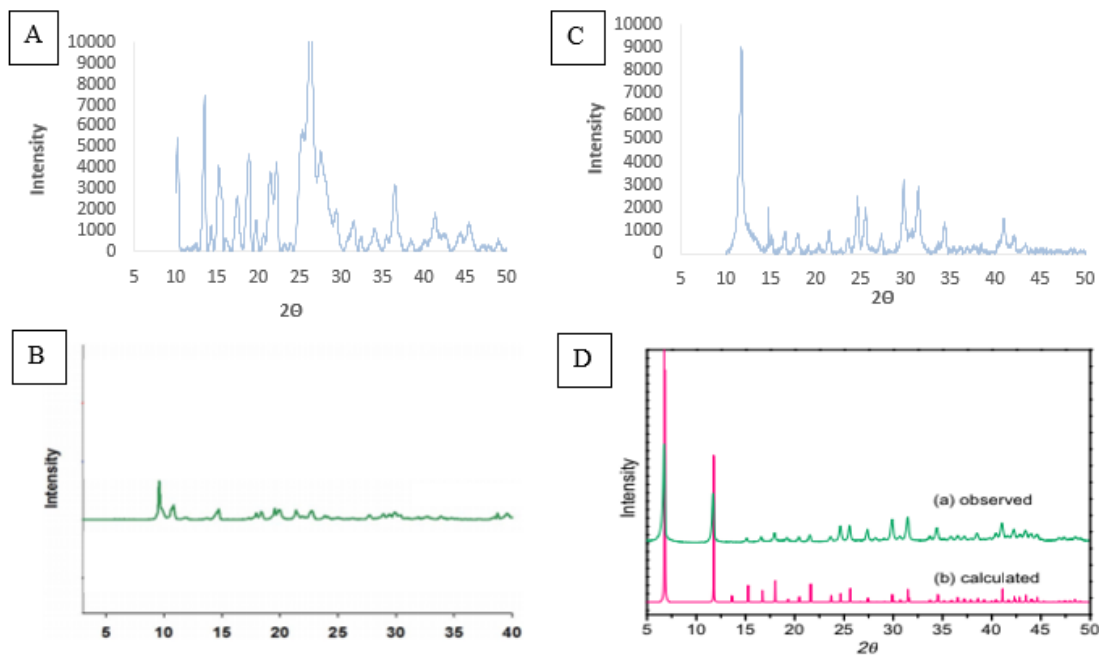
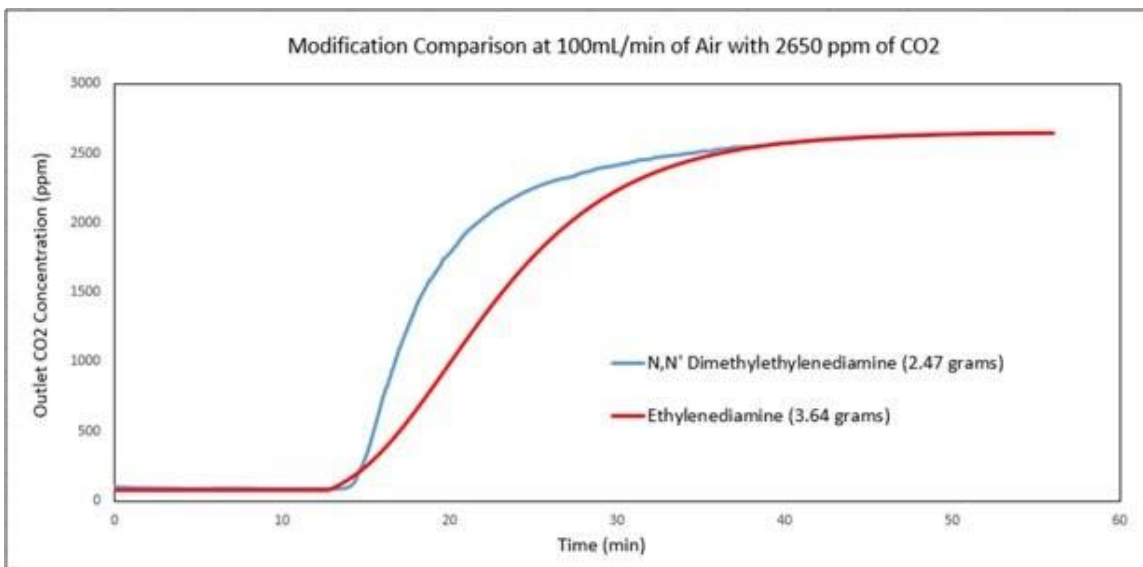

Figure 4: a) Experimental PXRD for Mg-MOF-BPDC b) PXRD for Mg-MOF-BPDC recorded in literature^[2] c) Experimental PXRD for Mg-MOF-74 d) PXRD for Mg-MOF-74 recorded in literature^[1]

Figure 7: Breakthrough curves of both amine groups normalized to 2650ppm.



As seen in **figure 4**, both synthesized Mg-MOF-74 and Mg-MOF-BPDC were analyzed by X-Ray Diffraction (XRD) and compared to the ones reported in literature. c

FIG 4b: TGA of Mg-MOF-BDC

Pressure Swing CO₂ Scrubber Test

Results

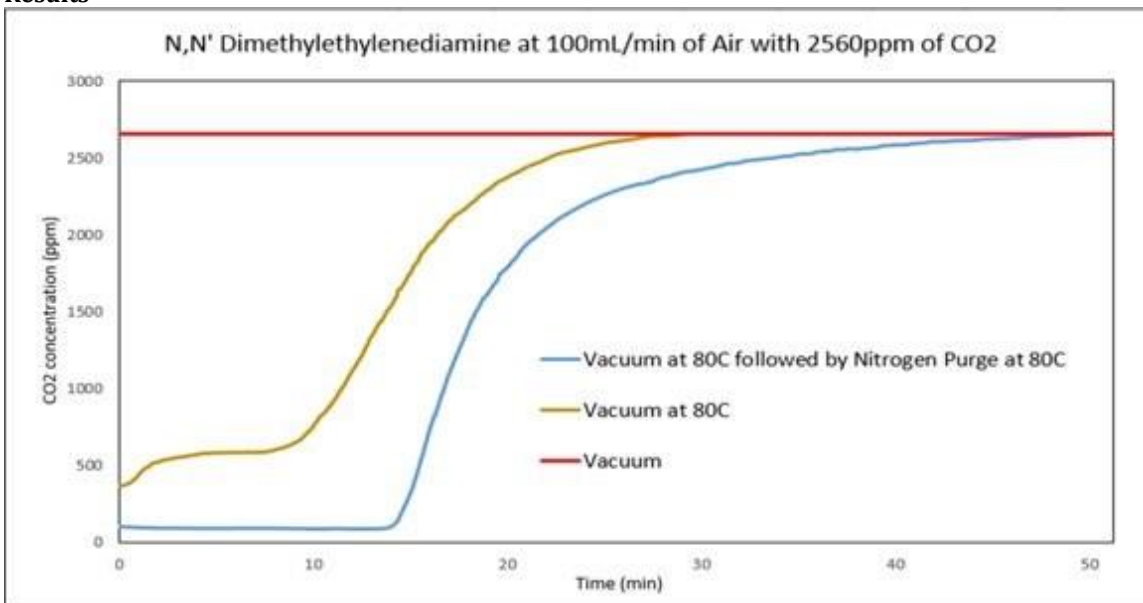

Figure 8: Adsorption cycles of N,N'-Dimethylethylenediamine with different desorption conditions

In

Figure 7 the breakthrough curves for both amine groups are shown. Using a mass balance, a capacity of both the N,N'-Dimethylethylenediamine and Ethylenediamine were found to be 0.154 mmol/g and 0.117 mmol/g respectively. This conveys that the N,N'-Dimethylethylenediamine was more effective for adsorbing CO₂ due to its higher capacity. Further pressure tests were ran with this amine group and are illustrated in **Figure 8**. Even though the N,N' amine group showed a higher capacity, it also showed higher energy requirement to desorb it. Since the secondary amine groups on N,N'-Dimethylethylenediamine create stronger basic interaction sites, it requires higher energy to break these interactions. In the system tested, vacuum alone was not enough to desorb the CO₂. Temperature aided desorption at 80C was needed to overcome this interaction.

More test will have to be conducted to evaluate the modified MOF performance over long pressure cycles. This will also aid in estimating scale up designs. Different temperature desorption cycles can also be tested to

determine minimum desorption energy requirements. Since in this study N-Methylethylenediamine was not tested in long-term pressure cycles, appropriate testing could reveal its effectiveness in adsorbing in a pressure cycle system.

ACKNOWLEDGMENT

This study could not be possible without the help of the student lead research team, Iowa State XHAB. In partnership with NASA, this work will be further developed and tested by the team. The following resources were critical in aiding this research: Dr.Slowing's lab under Ames Lab, Howe Hall's space research lab under Dr.Lee, and technical help from Dr.Paskach from the chemical engineering department.

9 Internal and External Interfaces

9.1 Internal Interfaces

Internal interfaces in the system can be divided into mechanical interfaces and data interfaces. Mechanical interfaces will be defined as interfaces that allow for or cause the flow of fluid through the system. Data interfaces will be data collected and communicated from sensors and GUI inputs to the system's computer, the Arduino Mega, as well as signals sent out from the Mega.

The system's mechanical interfaces operate in a very linear fashion, where there is typically one fluid input and one fluid output of each component. For the final scaled version, open/close control and directionality control on 2-way and 3-way valves will enable the divergence of flow from one path to another. The system will stick to stainless steel piping for most of the system, which will simplify the connections between components. Diverging or converging pipe fittings will be used when necessary.

The system utilizes many sensors to drive automation and to monitor activity. The Controls team is currently at work writing code using Simulink software to control the automation, which will allow the Omega to process all data inputs correctly and send output commands to components. A detailed wiring plan will also be necessary for the system and will be finalized when component lists and vendors are finalized.

9.2 External Interfaces

External interfaces with the vessel or habitat will include power hookups, data communication connections, and mechanical attachments. The total power input of the system is still undergoing final calculations, but as stated before will be targeted to around 1000 Watts average. The system will likely use one main power hookup and use a power distributor to distribute power throughout the system. One method of avoiding system malfunctions and failures will be for ground control to have access to data collected by sensors, so that bodies outside of the crew can monitor activity. Methods for communicating data to ground control is still being figured out but may utilize communication equipment already in use by the vessel.

The main mechanical attachment to the system will be long-term CO₂ storage. If storage containers are already supplied on the vessel, it will be a matter of establishing the correct connections for the system to transport CO₂ into the storage containers. If this is the case, then the system will have to be placed and secured near the storage in a way in which major components will be unobstructed by surrounding equipment. In alignment with NASA's commitment to In-Situ applications, one possible destination for CO₂ the group has considered is NASA's Sabatier Reactor, which would mix H₂ and CO₂ to produce useful H₂O and CH₄. This would provide a way to repurpose CO₂ captured that might otherwise go to waste.

The main interface for the crew will be with the GUI display. Through this display, the crew will be able to view system performance and sensor data, view system alerts, and manually control the processes. Below is an image of what several screens of the GUI will look like. More information on navigating this GUI is provided in Section 8.



The system will likely be enclosed in a small container that stores all major components. As the system will have to undergo regular maintenance and be able to be easily repaired, the group is designing the system so that each component will be easily accessible. The modularity of components will also help the crew effectively and easily replace and repair components. The maintenance of the system is covered in more depth in section 8.

10 Physical Environment

The scope of the team's design will concentrate mostly on a Mars mission application but will include considerations for pure space as well. On Mars, the system will be subject to harsh temperatures, strong pressure differentials, and reduced gravity. Due to the thin atmosphere of Mars, the ambient temperature on the surface can range from -70 to 20 Celsius every day. Both the extreme cold, as well as the dramatic fluctuation will need to be taken into consideration. The atmospheric pressure on Mars is 0.006 atm, a near vacuum when compared to Earth's surface pressure of 1 atm. The habitat or vessel the system will be integrated onto will be kept at or near 1 atm. As the system will attempt to use the ambient pressure outside the vessel in the PSA or VPSA system, portions of the system could be harmed by strong pressure differentials. At these points, a structural analysis will be key. As Mars has much less mass than Earth, there is much less gravitational pull. In the case of ISS or other deep space vessels, there

will be micro- to zero- gravity. Further investigation into the effect of these conditions will be necessary.

11 Support Environment

As with any mechanical system, some regular maintenance will be required. The philosophy of preventative care will be embraced by the crew, as manuals describing routine care will be written and included with the system. For example, compressor pumps such as the ones implemented by the team are usually recommended to have yearly maintenance, and valves will have to be routinely checked to ensure dust particulates from the MOF are not accumulating. A clog caused by such particulates could result in downtime of the system until repaired. This is one known issue with CDRA and is something the group is aiming to prevent using frits and routine inspection. Servicing procedures are currently being written by the team.

In the event of component failure, it will be important for the crew to be able to a.) identify the problem, b.) Know how to fix the problem, c.) Have competent skills to implement the fix, and d.) Know how to ensure that the problem is fixed. This will require the crew to undergo some training on how to operate and navigate around the system. In addition, the group has written a manual that will guide the crew on how to navigate around and use the GUI display. Loaded onto the system computer, and kept on file as a paper copy, will be a manual that includes instructions on how to navigate the GUI, a description of the system and its components, and troubleshooting and maintenance instructions. These Instructions will become available nearing further completion of the system.

Crews shall be trained on the following

- Disassembly.
- Reassembly.
- Maintenance.
- Troubleshooting of GUI Alerts.
- Part disposal in case of contamination.

11.1 Assembly and Cleaning

Electrical Connections:

- Disconnect from Power Supply
- Verify that power supply data matches motor data

Pneumatic Connections:

- Verify Hoses are suitable for maximum operating pressure.
- Chemically Resistant Hoses should be used for material pumped.

Cleaning:

- Clean outside housing with dry wipes.
- Cleaning solvents may corrode plastic components.
- Isolate pump from power supply.
- Disconnect hoses.

12 Operational Scenarios and Use Cases

12.1 Nominal Conditions

Nominal conditions will be characterized by standard atmospheric temperature and pressure within the habitat or vessel, where the system will be integrated. The Carbon content of the vessel should be between 400 ppm and 2700 ppm, as the system will be designed to filter CO₂ at 2650 ppm.

12.2 Off-Nominal Conditions

Off-nominal conditions are characterized by a large deviation from standard temperature and pressure conditions within the vessel, increased CO₂ content, and component failure. The event of deviation from standard temperature and pressure within the vessel would likely be caused by the failure of heating systems, or punctures or holes in the vessel or habitat, and would clearly need tending to immediately. Materials selection in the CO₂ filtration system would need to be chosen to account for the possibility of these conditions, a subject further discussed in Section 12. Increased Carbon content would likely be caused by downtime in the system or increased physical exertion by the crew. In the event of system downtime, maintenance would need to be done immediately, as high CO₂ content can have adverse effects on crew members. The software system will be designed to detect the increased content through CO₂ sensors and adjust the operational rate of the system and will have a redundancy system that allows the capability for the crew to manually control the system and execute stop and start purge cycles. Further information of how the crew will interact with the system is detailed in Section 8.

13 Impact Considerations

13.1 Organizational Impacts

Successful design and implementation of the system would require the manufacturing (and possible mass manufacturing) of the components and assembly. Crew members would need to be trained on the operation and support maintenance of the system.

13.2 Scientific/Technical Impacts

Successful design and implementation of the system would expand the capabilities of human space travel drastically. Carbon removal and repurposing is one of the major challenges blocking current deep space travel. A successful system could allow for deep space travel and habitation of foreign planets.

14 TRL-4: Sources of Error and Future Recommendations

14.1 Sources of Error

During the testing in section 8.1, there were multiple potential sources of error. For the CO₂ sensor, every breakthrough curve did not read 2650 ppm at breakthrough. This resulted in the breakthrough curves being normalized to 2650 ppm which decreases the accuracy of the adsorption capacities. As for the Arduino, an instance did occur where the software froze and the heat tape temperature was raised to approximately 100C at an unknown time during the vacuum step of Ethylenediamine from Figure 9. As for system leaks, if the system was not completely sealed during vacuum desorption then the pressure of the packed bed would not reach a pressure low enough to desorb CO₂. All of these potential sources of error may have affected our results in section 8.1.

14.2 Future Recommendations

There are many modifications that can be made to the TRL-4 test bench. A higher quality CO₂ sensor could be used to yield more accurate breakthrough curves and adsorption capacities. A redundant temperature probe, separate from the Arduino, could be used on the packed bed reactor to alarm if the temperature of the packed bed deviates. The test bed could be automated to continuously run adsorption and desorption cycles. A pressure sensor could be implemented into the system to accurately read pressure and see if the packed bed is actually reaching a pressure of 20 microbar during desorption. In order to avoid need a wrench to loosen a nut on the system to reintroduce pressure into the system after a vacuum desorption, a hand valve could be incorporated into the system. A final change could be implementing a cooling system, such as a water jacket, that would bring the system to room temperature (before adsorption) without having to remove any of the heating components. With these changes and additions to the TRL-4 test bench, more accurate data could be obtained, there could be a decreased chance of error, and new studies could be ran.

Moving forward there are multiple tests that could be ran on the TRL-4 test bench. The first test could be comparing longer and shorter vacuum desorption times. This could give insight on if the time of exposure to vacuum matters or if the system just needs to briefly reach vacuum to experience maximum desorption. Another test could be running a temperature study to find adsorption capacities after vacuum desorptions at various temperatures. This will reveal the lowest optimal temperature (lowest energy) to run the vacuum desorption that will result in a satisfactory adsorption capacity. Another test could be repeating the same desorption and adsorption conditions from section 8.1 with the base MOF. The base MOF data will show how the MOF modifications compare in terms of breakthrough times and adsorption capacity. A final test could be ran of running multiple desorption and adsorption cycles if the system was automated. This would show how each MOF would perform after continuous use for extended periods of time. With these additional tests, important data can be found that will directly influence the design of TRL-6.

15 Risk Mitigation

TRL-4

Risk	Mitigation
Front pressure Regulator Fixed	Regular test and inspections
Front Pressure Regulator Leakage	Regular test and inspections
Front Pressure Regulator Reduced Efficiency	Regular test and inspections
Mass Flow Controller Fails	Maintain gas cleanliness, regular test and inspection, ensure electrical connection is secure before operations
Mass Flow Controller Leakage	Maintain gas cleanliness, regular test and inspection
Mass Flow Controller Reduced Efficiency	An initial inspection and regular tests
Packed Bed Fitting Leak	Inspect and replace sealant tape on fitting whenever signs of wear occur. Ensure fitting is tighten properly beyond hand tight.
Packed Bed Implosion	Replacements
Packed Bed Fiber Wool Degradation	Monitorization of Packed Bed Material
Handling System	Manuals and Information. Regular test and inspection
Signal Temperature Failure	System Insulation
Signal Corrosion Failure	Inspections for corrosion
Displays Failure	Redundancy/ Spare Parts
Microcontroller Failure	Manual Redundancy
Power Plant Power Loss	Manual Redundancy
Pump Contamination	Packed Bed Filters
Pump Casing Rupture	Pressure/Relief Valves
Pump Failure	Monitor Pump activity Test Sensors to verify operational status
Valve Damage	Test Reduction of Chatter effect
CO ₂ Network Leakage	CO ₂ sensors and pressure gages

TRL-6

CO ₂ Sensor Failure	Replacements
Powered Valve Failure	Feedback loop detection
Compressor Failure	Replacement systems/ monitorization
Signal Temperature Failure	System Insulation
Signal Wiring Corrosion	Inspections for corrosion
Displays Failure	Redundancy/ Spare Parts
Microcontroller Failure	Manual Redundancy
Power Plant Power Loss	Manual Redundancy
Pump Contamination	Packed Bed Filters
Pump Casing Rupture	Pressure/Relief Valves
Pump Failure	Monitor Pump activity Test Sensors to verify operational status
Valve Failure	Test Reduction of Chatter effect
CO ₂ Network Leakage	CO ₂ sensors and pressure gages
Signal Failure	System Insulation
Signal Corrosion	Inspections for corrosion
Packed Bed Fitting Leak	Inspect and replace sealant tape on fitting whenever signs of wear occur. Ensure fitting is tighten properly beyond hand tight.
Packed Bed Implosion	Replacements
Packed Bed Fiber Wool Degradation	Monitorization of Packed Bed Material

16 Costs

16.1 Costs

16.1.1 Synthesis

Component	Cost
Vial Caps Special	\$13.85
Vial Caps new	\$27.70
Methyl Alcohol	\$12.71
Gloves	\$15.66
Magnesium Nitrate Hexahydrate	\$114.86
2,5-dihydroxyterephthalic acid	\$191.00
2,5-dihydroxyterephthalic acid	\$324.00
DMF	\$339.50
Ethylenediamine	\$49.89
N,N'-Dimethylethylenediamine	\$55.00
N-Methylenediamine	\$62.30
Pellet Die	\$2618.00
Total	\$3824.47

16.1.2 Process

Component	Cost
Test system hardware	\$2,849.62
Gas/Regulators	\$1,468.80
Glass Beads	\$39.13
Glass wool	\$27.12
Test Bench	\$600
MFC	\$918
CO ₂ sensor	\$213
1/2 Packed Bed	\$527
Wrenches	\$21
Insulation Wrap	\$9
Heating Equipment	\$92

Desiccant Bed	\$136
flow system for CO ₂ sensor	\$53
Bolts	\$15
Misc. for support	\$17
Swaging Equipment	\$125
Regulator Fittings	\$0
Desiccant Bed Fitting	\$55
lots	\$70
Mesh Screen	\$12
CO ₂ Sensors	\$800.00
CO ₂ sensor connection	\$20
Total	\$8,088.23

16.1.3 Design

Component	Cost
Pump	\$6,500
Total	\$6,500

16.1.4 Controls

Component	Cost
Raspberry Pi 3 B+ Microcontroller x2	\$81
Arduino Microcontroller	\$40
Solderless Breadboard	\$10
Driver circuits (x5)	\$12 Per Value
Power Supply circuits	\$75-150
Wires and connectors	~\$20
Perfboards	~\$30
PCB creation	~\$80
Misc. Electrical Components	\$50
HDMI Raspberry Pi 7" Touchscreen	\$88
Total	~\$589

17 Educational Outreach

The educational outreach was at Plainfield North Highschool. Mr. Patel let our group present to some of his stem classes. During this we talked about STEM careers, and how NASA encourages people to do STEM. We also talked about our project and the type of work NASA requires and how it is very interesting. Then as a group we gave advice to students as most of them were going into college. Since we have a vast majority of STEM people on the project, we were able to explain how each major aided in help to the project. We also explained that if the group was funded for another X-hab that we would include a high school student and mentor them.

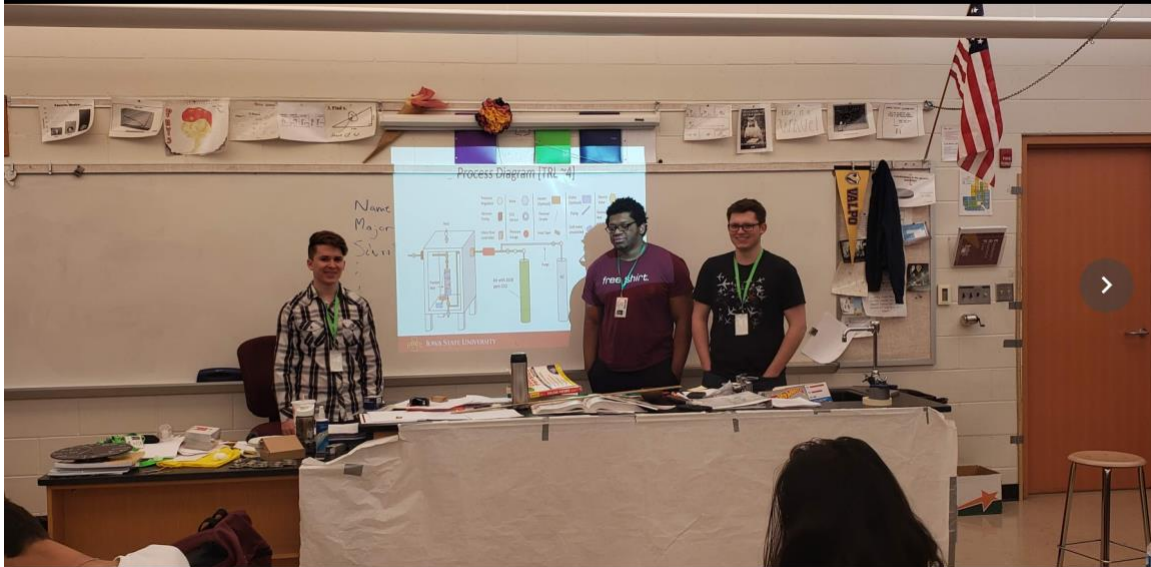

18 Documents

18.1 Applicable Documents

- [1] et al, *CO₂ Removal System Technological Assessment Requirements from NRA announcement*
- [2] NASA Headquarters Human Exploration & Operations Mission Directorate, *eXploration Systems and Habitation (X-Hab) Academic Innovation Challenge - FY19 Solicitation*

18.2 Reference Documents

- [3] Dina El Sherif, James C. Knox, *International Space Station Carbon Dioxide Removal Assembly (ISS CDRA) Concepts and Advancements*
- [4] Steven R. Hirshorn, et al. *NASA Systems Engineering Handbook*
- [5] Engineering Data Book. Gas Processors Suppliers Association, 1994.
- [6] "Design and Operation of Molecular Sieve Units."Shell Global, www.shell.com/business-customers/global-solutions/featured-stories/design-and-operation-of-molecular-sieve-units.html.
- [7] Thomas, H.C., 1944.Heterogeneous ion exchange in a flowing system. J. Am. Chem. Soc., 66: 1664-1666.
- [8] Zongbi Bao, Liang Yu, Qilong Ren, Xiuyang Lu, Shuguang Deng. *Journal of Colloid and Interface Science* 353 ,2011,549–55
- [9] Apurba Biswas, Min-Bum Kim, Seo-Yul Kim, Tae-Ung Yoon, Seung-Ik Kim, Youn-Sang Bae. *RSC Adv.*, 2016, 6, 81485

19 Appendices

A Acronyms

- BDST - Bed Depth Service Time
- BET – Brunauer-Emmett-Teller theory
- CAD – Computer-Aided Design
- CDRA - Carbon Dioxide Removal Assembly
- GUI - Graphical User Interface
- ISS - International Space Station
- MOF - Metal Organic Framework
- MSFC - Marshall Space Flight Center
- NASA - National Aeronautics and Space Administration
- ppm - parts per million
- PSA - Pressure Swing Adsorption
- PXRD – Powder X-Ray Diffraction
- TCS - Thermal Control System
- TGA - Thermogravimetric Analysis
- TRL - Test Readiness Level
- TPD - Temperature Programmed Desorption
- TPR - Temperature Programmed Reaction
- VPSA - Vacuum Pressure Swing Adsorption
- V&VP - Verification and Validation Plan
- X-Hab - eXploration Systems and Habitation