

Overview of Multi-Layer Metal Insulation Development for Small Stirling Convertors at NASA GRC



Daniel Goodell, Nicholas Schifer, Scott Wilson
Thermal Energy Conversion Branch (LET)

AIAA Propulsion And Energy Conference 8/19/2019 – 8/22/2019
J.W. Marriott Hotel, Downtown Indianapolis, Indiana
Session ECD-01: Stirling Energy Conversion Components and Analysis



Background – 1 Watt Stirling Converter Prototype

- Low Power – 1 Watt electrical output
- Radioisotope Power Source
- Two orders of magnitude less power than state-of-the-art convertors.
- Mass and size not a constraint for the development prototype

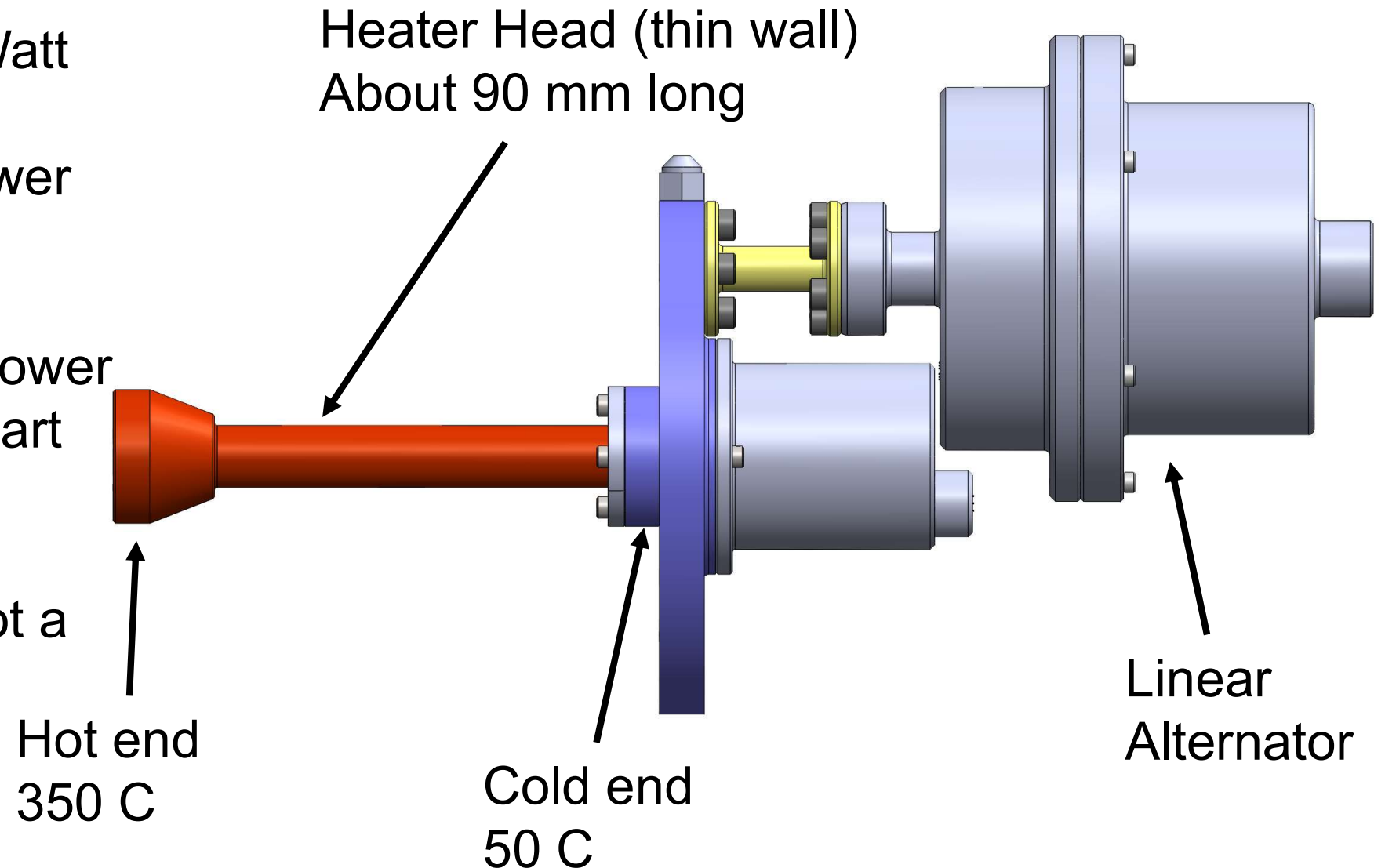

Background – Radioisotope Heat Sources

General-Purpose Heat Source (GPHS)

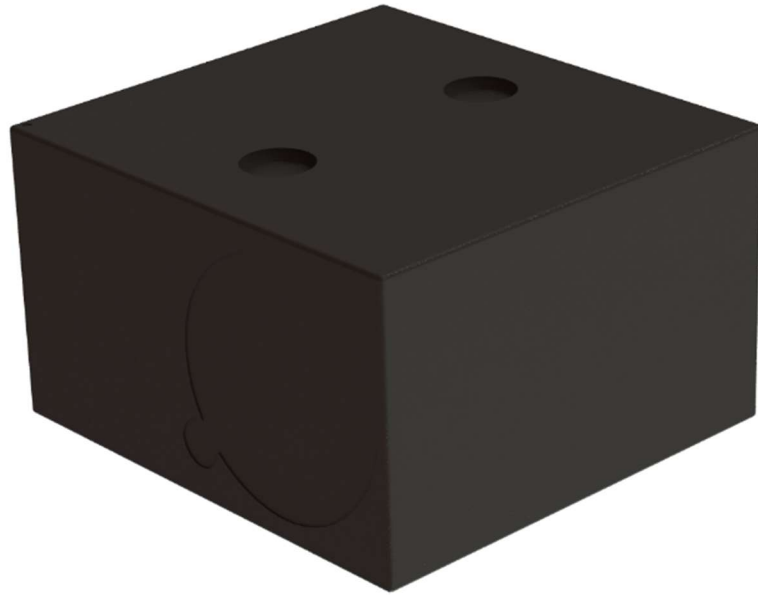

Heat Output: 250 W
Mass: 1770 g
Dimensions: 5.8x9.3x10 cm
Power Density: 0.46 W / cm³
Power / Surface Area: 6000 W / m²

Light-Weight Radioisotope Heater Unit (LWRHU)



Heat Output 1 W
Mass: 40 g
Dimensions: h=3.2 cm, ø=2.6 cm
Power Density: 0.059 W / cm³
Power / Surface Area: 272 W / m²

LWRHU has much lower power quality than the GPHS

Problems

1. Microtherm HT $\sim 0.02 \text{ W / m} \cdot \text{K}$ – not good enough
Need much better insulation for the engine to function.

2. Thin heater head cannot support the mass of a large heat source – Wall thickness is only 100 micron (0.004")

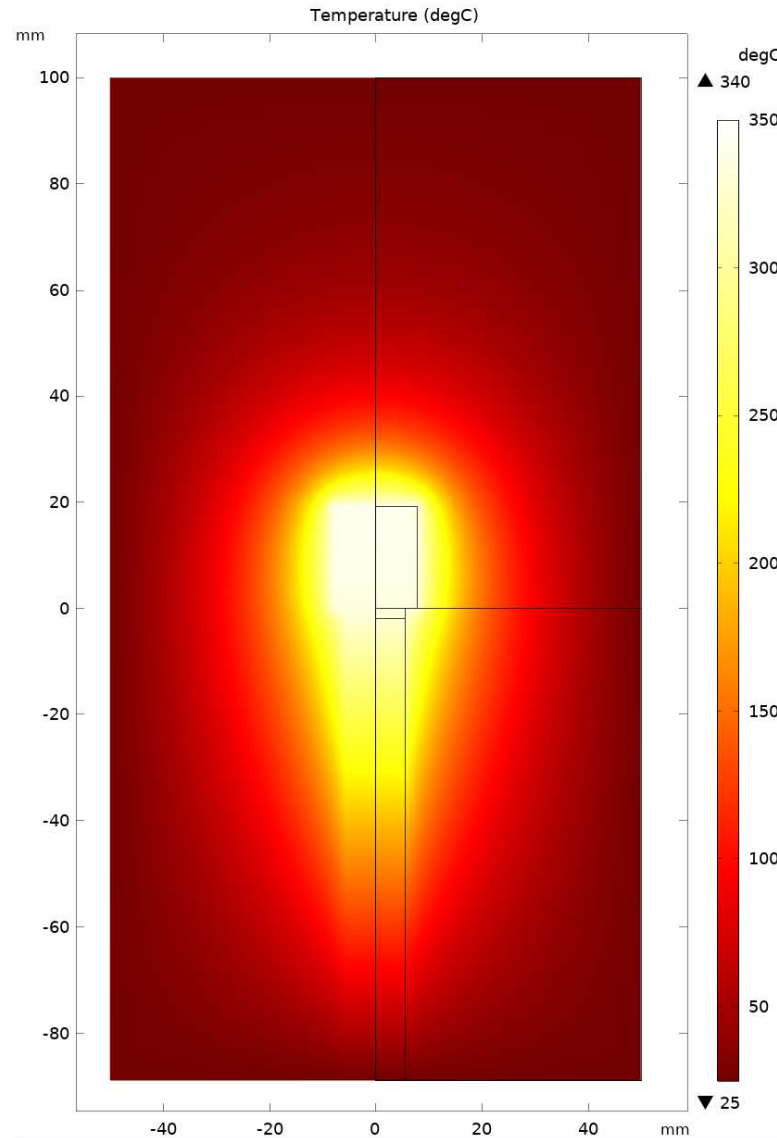

Lost through insulation:

1.5 W

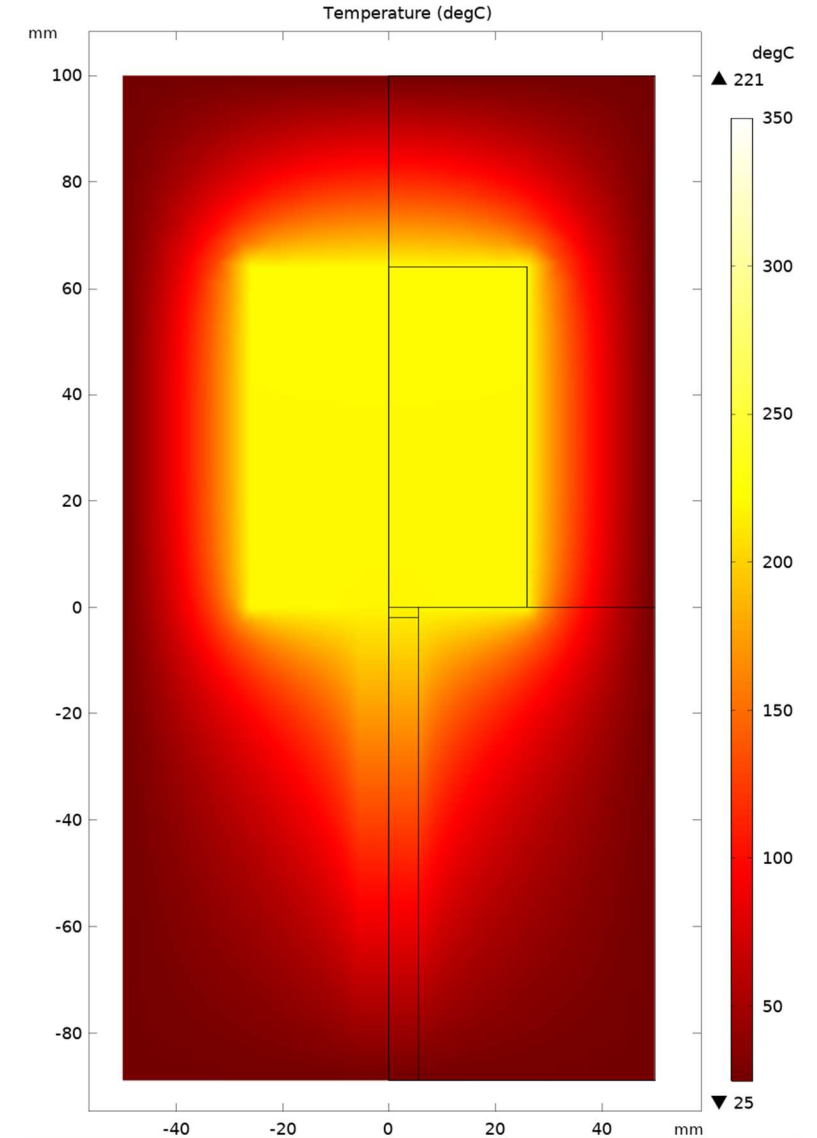

3.9 W

Solutions

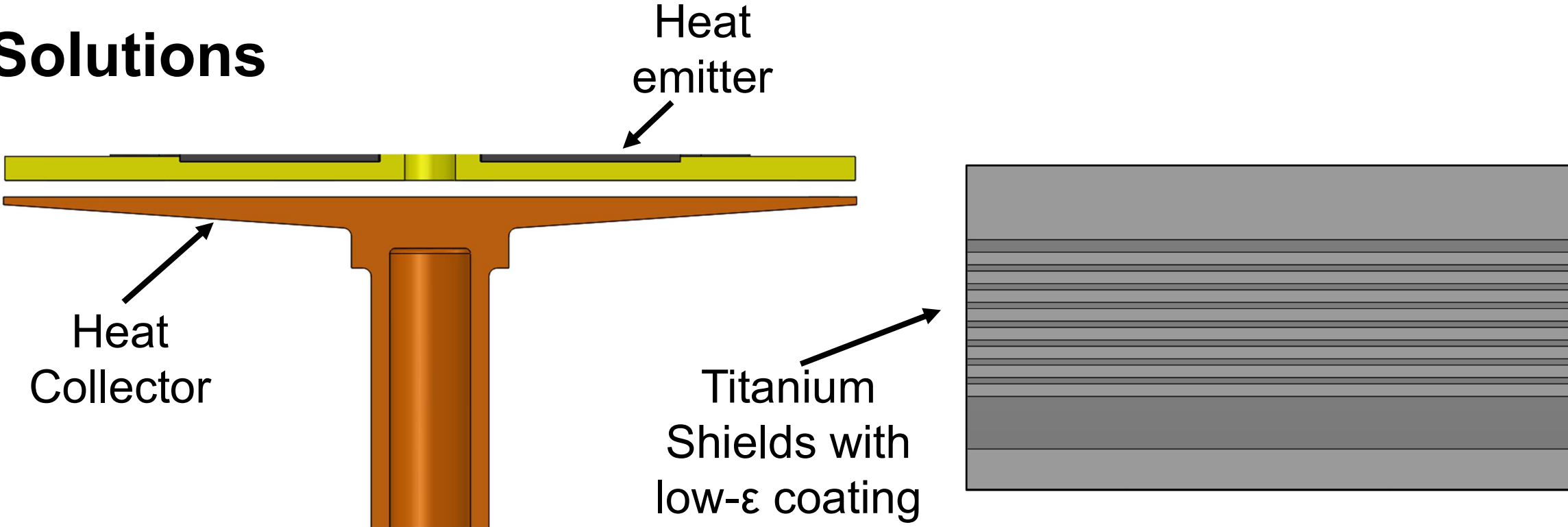

Radiative Coupling using large area heat collector.

Multi-layer Metal Insulation (vacuum)

Radiative Heat Transfer equation:

$$P = e\sigma A(T^4 - T_C^4)$$

Prototype Development

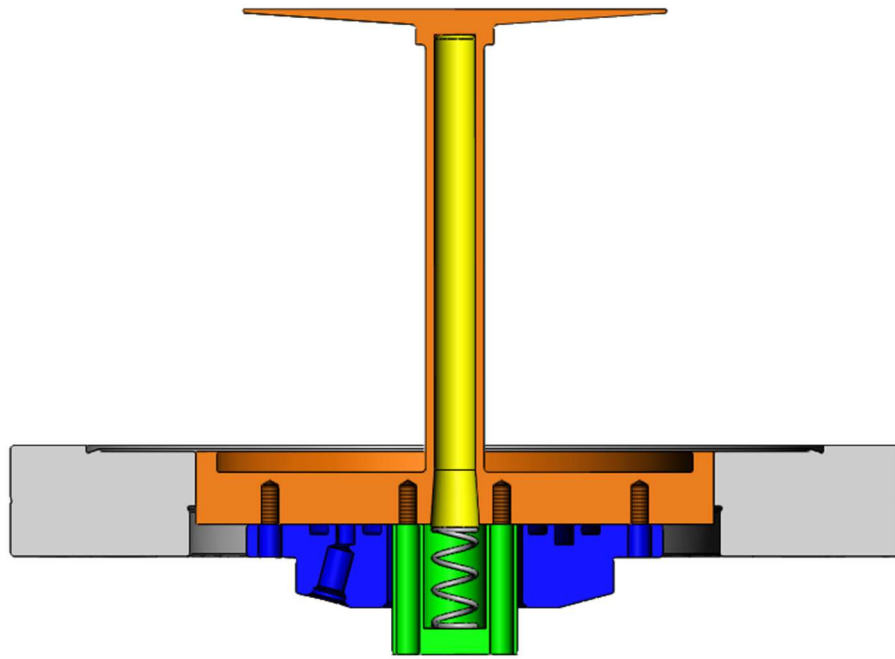

Thermal Simulator Assembly
simulates 1 W Stirling
convertor at full power



Electrical Heat Source
simulates 8 x LWRHU

Complete Insulation Prototype

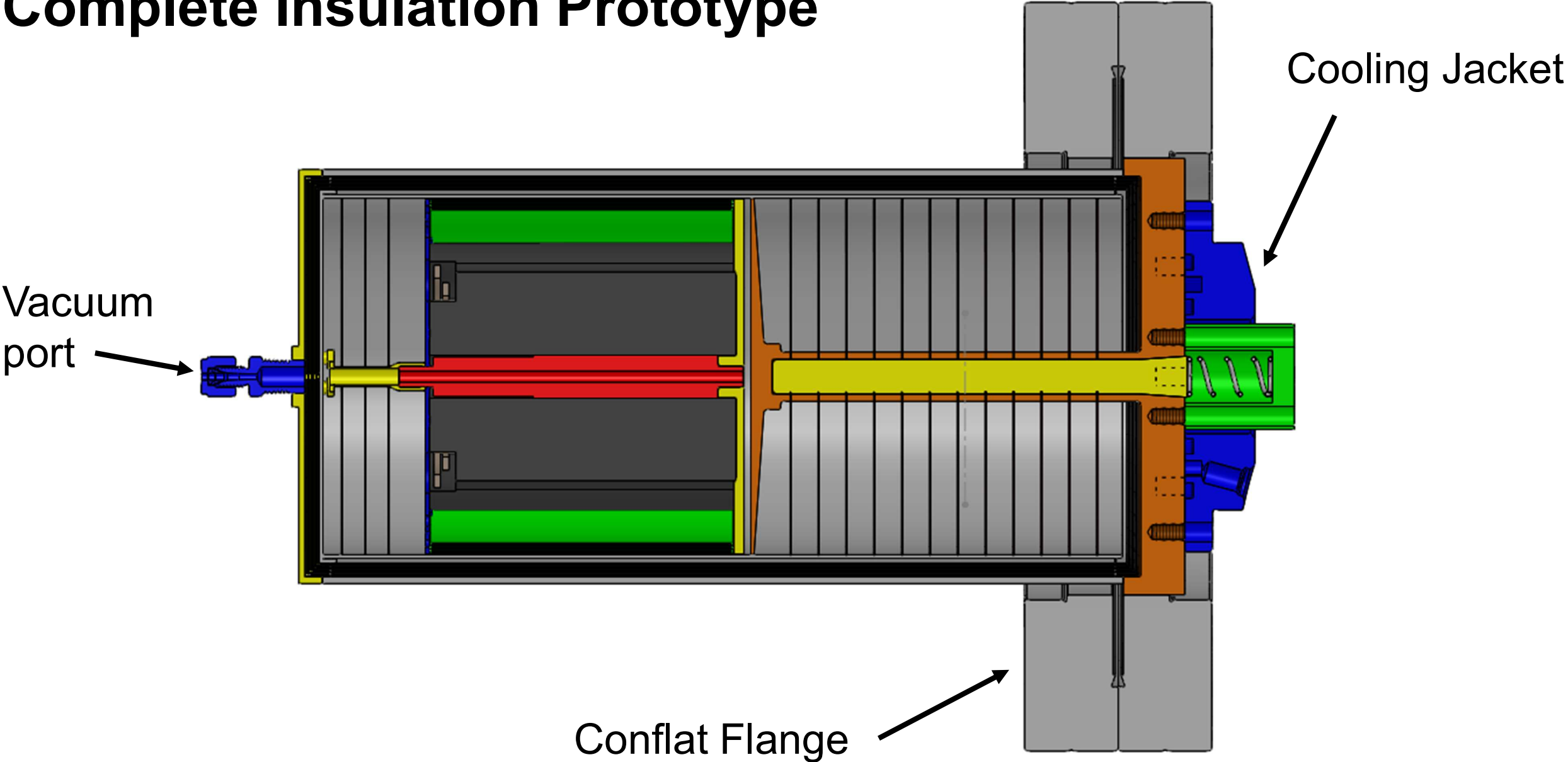

Thermal Analysis of the Prototype

- Comsol model based on the design of the insulation package but does not include any conduction paths between the heat source and the outer case.
- Results show that this design can meet the design requirements if conduction losses are low and the foil emissivities are low.
- 18 cases run with different ambient conditions, and material properties.
- The largest unknown is the conduction losses. A comparison between the thermal model and test results will help to resolve this.

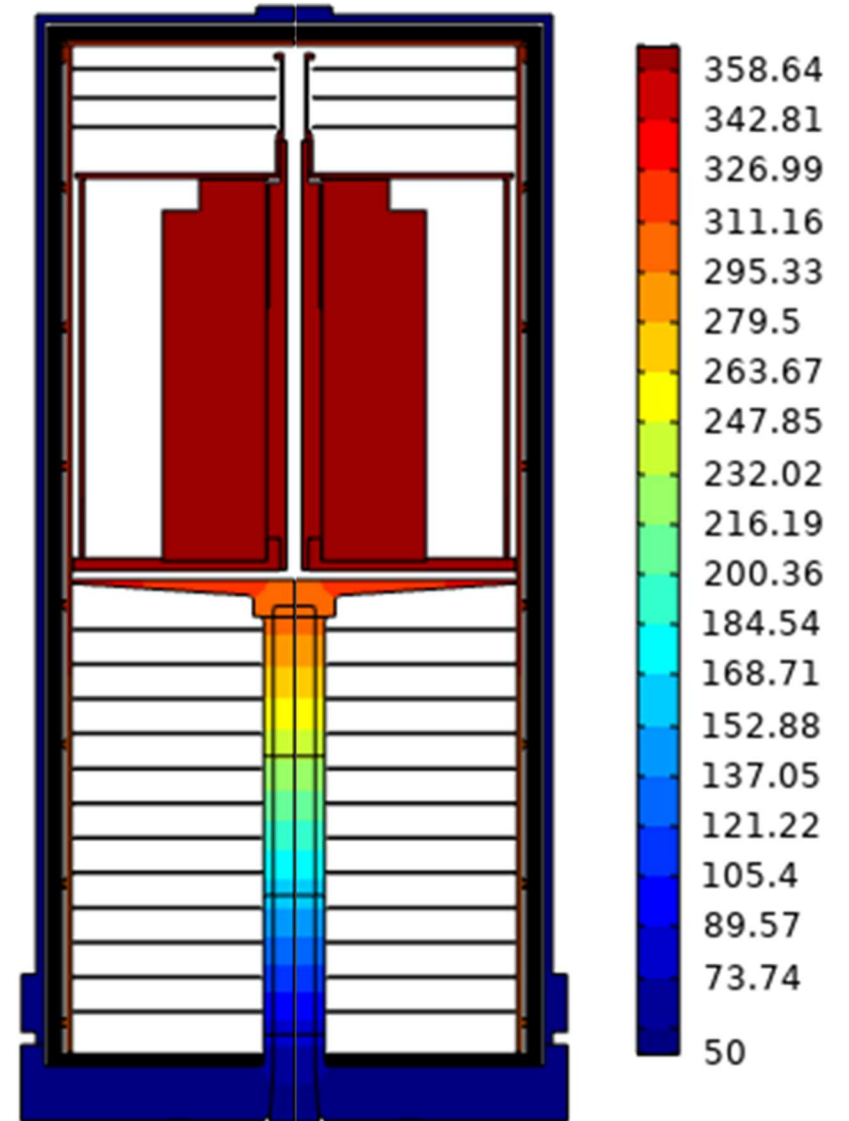

Testing

Test Setup:

- PID controlled heater
- Circulated chiller
- 13 thermocouples
- LabVIEW data collection
- High-vacuum, oil-free pumping station

Test Matrix:

- rod_1_tc :100-300 C
- 25 & 50 C circulator setpoints

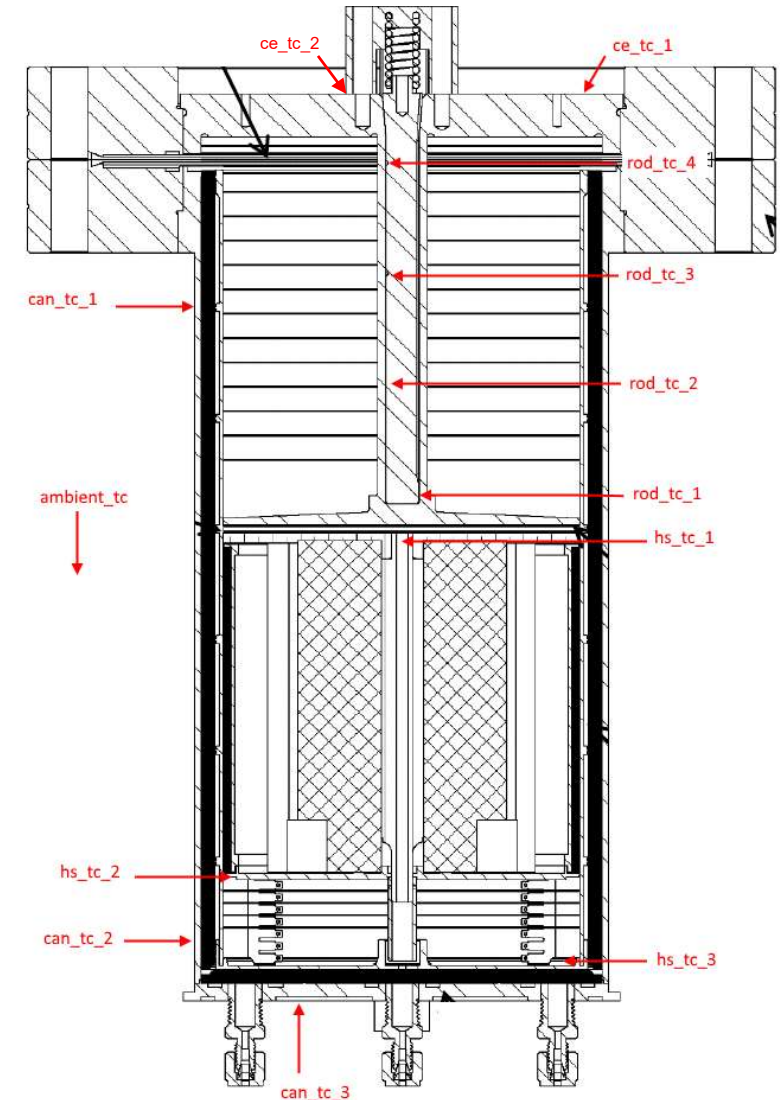

Test Results

| | | 100 C | 150C | 200 C | 250 C | 300 C |
|-----------------------|---|------------|-------------|-------------|-------------|-------------|
| Rod 1 TC | C | 99.3 | 150.8 | 200.7 | 251.4 | 300.3 |
| Rod 2 TC | C | 81.2 | 120.8 | 159.6 | 199.3 | 237.1 |
| Rod 3 TC | C | 61.4 | 87.5 | 113.3 | 140.3 | 166.1 |
| Rod 4 TC | C | 39.6 | 50.3 | 61.1 | 72.6 | 84.0 |
| Heat Source TC | C | 182.1 | 250.2 | 314.9 | 363.4 | 407.5 |
| Cold End TC | C | 25.1 | 26.9 | 27.9 | 29.2 | 30.8 |
| Outer Case 1 TC | C | 33.7 | 42.0 | 51.2 | 66.3 | 90.6 |
| Outer Case 2 TC | C | 31.6 | 38.8 | 47.3 | 62.1 | 86.8 |
| Outer Case 3 TC | C | 28.6 | 33.8 | 40.1 | 52.1 | 73.0 |
| Electrical Heat Input | W | 5.8 | 10.6 | 16.2 | 25.5 | 40.6 |
| TS Heat Flow Calc. | W | 1.5 | 2.5 | 3.4 | 4.4 | 5.3 |
| Ins Heat Loss Calc. | W | 4.3 | 8.1 | 12.7 | 21.1 | 35.3 |
| % Through Insulation | % | 74.5 | 76.6 | 78.8 | 82.9 | 87.0 |

Goal: ≤ 1.5 W insulation loss at 350 C
 Prototype: 35 W insulation loss at 300 C

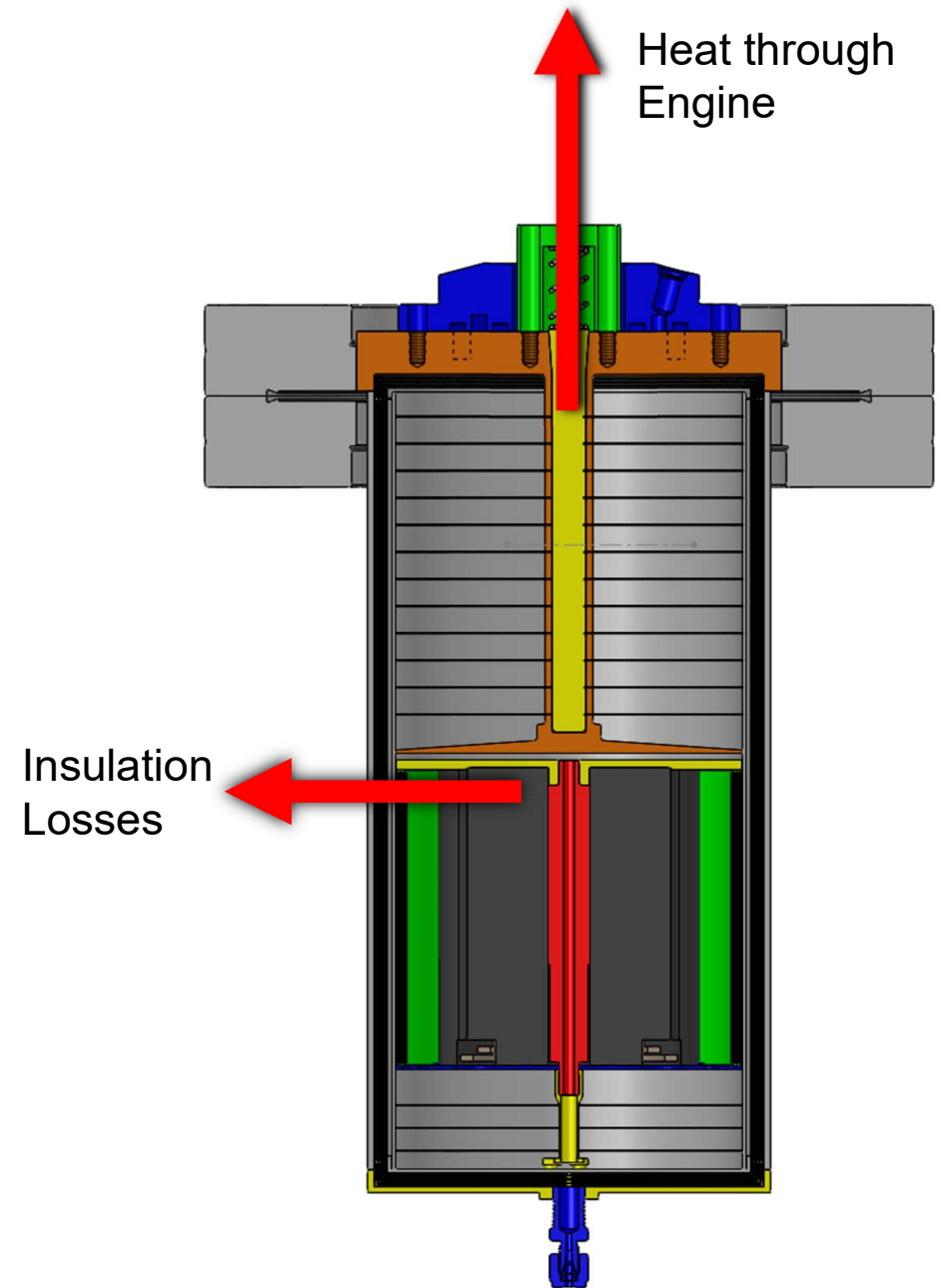

Comparison With Model

The model only includes radiation losses from the heat source, the conduction is not modeled.

The model was adjusted to match a test point. The difference in heat inputs is the conductive insulation loss.

Conduction losses are much larger than expected. This suggests that either the insulation has much more conduction than expected or it is not well evacuated.

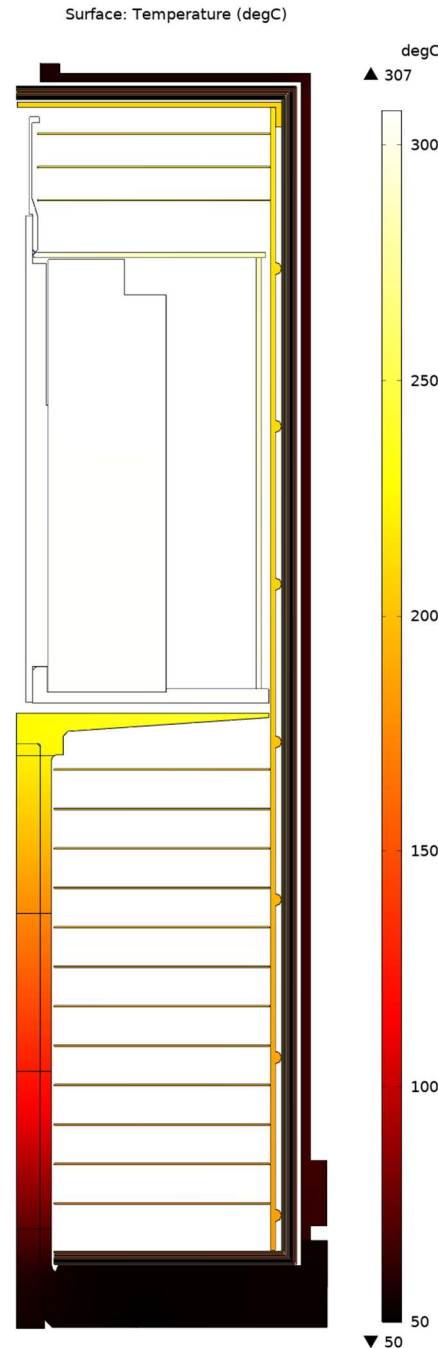

| | | Model | Test |
|-----------------------|---|-------|------|
| Heat Source TC | C | 306 | 308 |
| Outer Case 1 TC | C | 65.0 | 66.9 |
| Outer Case 2 TC | C | 57.0 | 57.5 |
| Rod 1 TC | C | 221 | 223 |
| Rod 2 TC | C | 175 | 181 |
| Rod 3 TC | C | 126 | 135 |
| Rod 4 TC | C | 73.0 | 82.5 |
| Cold end TC | C | 52.0 | 49.7 |
| Electrical Heat Input | W | 10.2 | 22.2 |
| Heat Through Engine | W | 3.64 | 3.67 |
| Insulation Loss | W | 6.6 | 18.6 |
| % Insulation Loss | % | 64.3 | 83.5 |

Estimated conduction losses
 $18.6 - 6.6 = 12 \text{ W}$

Problem - Underperformance

1. Long pump down times due to small port. 0.022" (0.56mm) inner diameter

$$\text{pumping rate} \propto \frac{d^3}{l}$$

2. Unknown vacuum level inside the insulation package.

3. Cylindrical shield emissivities higher than the expected 0.1. Actual value estimated to be 0.6 based on assembly images.

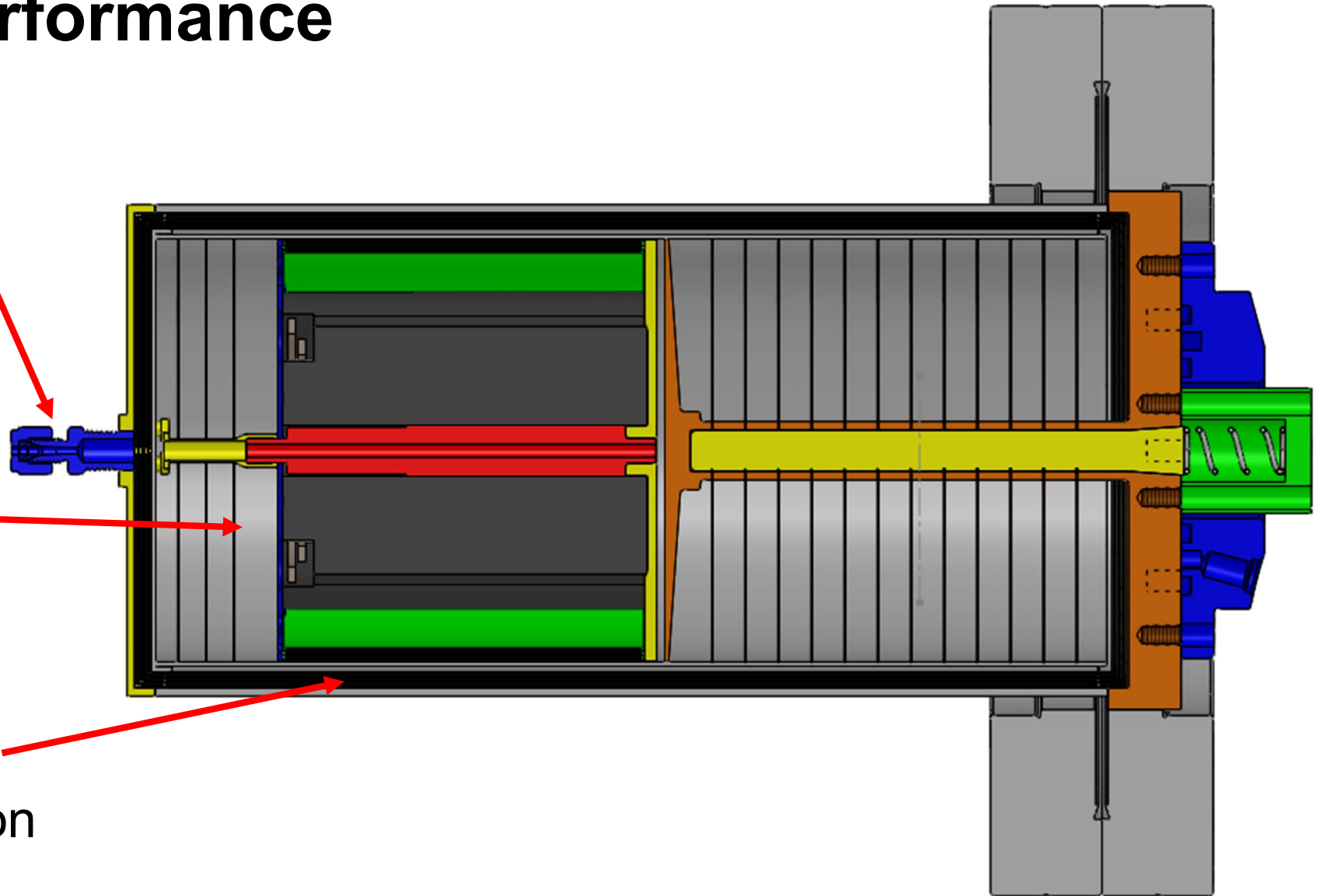

Next Steps

- Larger vacuum port & direct vacuum level measurement
- Disassemble package, understand the actual emissivities of the materials and update model with this info to increase accuracy.
- Modify the insulation prototype to improve some material properties, such as improving shield emissivity.
- Once we fully understand the performance of our prototype we will design and manufacture a more accurate prototype.