

Optical system design and integration of the Global Ecosystem Dynamics Investigation Lidar

Shane Wake*^a, Luis Ramos-Izquierdo ^a, Bente Eegholm^a, Peter Dogoda^b, Zachary Denny^c, Michael Hersh^a, Michael Mulloney^d, W. Joe Thomes^a, Melanie N. Ott^a, Hali Jakeman^a, Demetrios Poullos^f, Peter Mule^a, Erich de Leon^a, J. Bryan Blair^a

^aNASA/Goddard Space Flight Center, Greenbelt, MD USA 20771; ^bSigma Space Corporation, Lanham, MD USA 20706; ^cScience Systems and Applications Incorporated, Lanham, MD USA 20706; ^dStinger Ghaffarian Technologies Incorporated, Greenbelt, MD USA 20770; ^fThe American University Department of Physics, Washington, DC USA 20016

ABSTRACT

The Global Ecosystem Dynamics Investigation (GEDI) instrument was designed, built, and tested in-house at NASA's Goddard Space Flight Center and launched to the International Space Station (ISS) on December 5, 2018. GEDI is a multi-beam waveform LiDAR (light detection and ranging) designed to measure the Earth's global tree height and canopy density using 8 laser beam ground tracks separated by roughly 600 meters. Given the ground coverage required and the 2 year mission duration, a unique optical design solution was developed. GEDI generates 8 ground sampling tracks from 3 transmitter systems viewed by a single receiver telescope, all while maximizing system optical efficiency and transmitter to receiver boresight alignment margin. The GEDI optical design, key optical components, and system level integration and testing are presented here. GEDI began 2 years of science operations in March 2019 and so far, it is meeting all of its key optical performance requirements and is returning outstanding science.

Keywords: GEDI, LiDAR, waveform, multi-beam, optical design, fiber optics, altimeter, laser

1. INTRODUCTION

The GEDI LiDAR instrument¹ is a multi-beam waveform LiDAR developed under a NASA Earth Venture Class Proposal Opportunity. GEDI is installed aboard the International Space Station's (ISS) Japanese Experiment Module (JEM) Exposed Facility (EF) from which it receives power, coolant, and communications. The mission science objective is for GEDI measurements to provide knowledge on CO₂ atmospheric concentrations from deforestation and predicted future forest absorption of carbon. In addition, GEDI observes how habitat disruption affects biodiversity through observations of deforestation. The GEDI LiDAR instrument is able to achieve its objectives through measuring the Earth's forests (canopy height and vertical structure) and surface topography by laser ranging from the ISS predicted nominal orbit altitude of 419 km. GEDI provides nominal 1 m vertical resolution canopy heights with 22±3 m footprint beams. Design and development of the GEDI Optical System took place over a period of 3.5 years. The GEDI Optics Team consisted of individuals with previous experience building NASA GSFC LiDAR systems for both space and aircraft applications. This experience and knowledge drove the optical design, integration techniques, alignment methods, and optical testing.

2. INSTRUMENT DESCRIPTION

GEDI has a mass of 519 kg, fits in a static volume of roughly 2 m by 1 m by 1.5 m, and has a 400 W average operational power. The heart of the optical system is the Optical Bench which holds all the alignment sensitive transmitter and receiver components. The Optical Bench is mounted within a Box Structure that includes the fiber-coupled detector modules, all electronics, and the interface to the ISS JEM-EF. A cover mechanism protects GEDI from debris and possible solar impingement at specific ISS orientations. GEDI can rotate ±5.6 degrees relative to the ISS for desired ground track pointing. Figure 1a shows a CAD model of the Optical Bench and Figure 1b shows a picture following its integration to the Box Structure.

*shane.w.wake@nasa.gov; phone 1 301 614-6299; fax 1 301 286-0204; nasa.gov

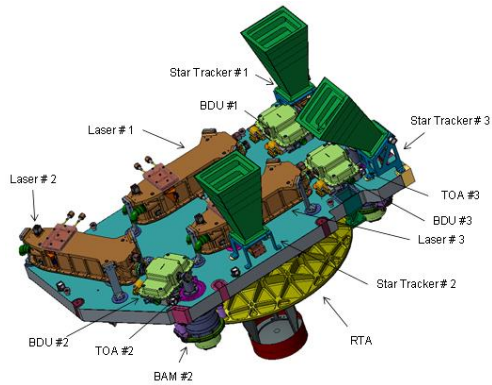

Figure 1a: Layout Model of Optical System

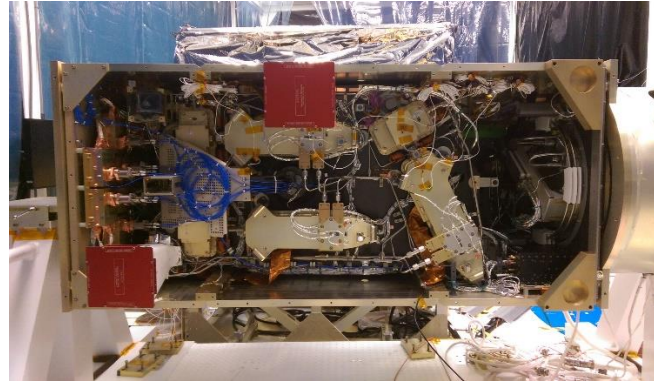

Figure 1b: Fully integrated Optical Bench to Box Structure

Two Transmitter Systems provide two 10.5 mJ dithered beams each to penetrate 98% of the Earth's dense tree canopies while a third Transmitter System provides four 4.2 mJ dithered beams for increased coverage while penetrating 95% of the Earth's dense tree canopies. Each Transmitter System consists of a ND:YAG pulsed laser @242 Hz², a Beam Dithering Unit (BDU) to dither the ground location of the transmitted beam of every other laser pulse, a Fold Mirror for nadir pointing, a Beam Expander for correct ground sampling size, and a Boresight Alignment Mechanism (BAM) that utilizes a Risley prism pair for boresight correction. To increase coverage, one of the Transmitter Systems utilizes a Diffractive Optical Element (DOE) to multiply its transmitted beams. Each of the eight transmitted beams are aligned to the eight Receiver Telescope Assemblies (RTA) Instantaneous Field Of Views (IFOV). The RTA is fiber optic coupled and each Receiver Fiber Optic Assembly, located at the RTA's focal plane, creates a unique IFOV and delivers the return pulses to multiple Detector Modules (DM). Each DM has a subassembly known as a Detector Optical Assembly (DOA) that contains a bandpass filter for solar background noise suppression. The DOAs have the capability to deliver four fiber inputs to a single detector element. The DOAs also receive corresponding laser start pulses via Start Pulse Fiber Optic Assemblies. Section 4 presents the development of key optical subsystems.

Originally, GEDI was to range to ten equally spaced ground tracks, but this was de-scoped to eight tracks during instrument integration and testing. The optical system design presented in the following sections depict the original ten channel design. Since the system design is modular, two Receiver Fiber Optic Assemblies were removed and one Transmitter System was re-configured to have two beam paths instead of four.

3. OPTICAL SYSTEM DESIGN

3.1 Receiver Optics

The GEDI Receiver Optical System is comprised of three subsystems: the RTA, six DOA's, and the ten Receiver Fiber Optic Assemblies that define the GEDI receiver FOV and connect the RTA to the DOA's/DM's. There are more Receiver Fiber Optic Assemblies than Detector Modules (DM) because some DMs receive two receiver inputs, which does not impact operations since the three GEDI lasers fire sequentially and only one ground return signal is present on each detector at any one time. The RTA is a 0.8 m diameter, Ritchey-Chretien, beryllium telescope manufactured by General Dynamics with custom refractive aft-optics manufactured by Optimax to yield diffraction-limited imaging performance in the VIS/NIR over a 1 degree diameter FOV. The GEDI RTA is the flight-spare RTA developed for the Advanced Topographic Laser Altimeter System (ATLAS)³ instrument currently operating on the Ice, Cloud, land Elevation Satellite-II (ICESat-II) mission. The ATLAS flight spare RTA was modified for using in GEDI in three ways: we replaced the refractive aft-optics with lenses anti-reflection (AR) coated for both the ATLAS 532 nm and the GEDI 1064 nm wavelengths, we added small field lenses located in front of each Receiver Fiber Optic Assembly to decrease the telescope focal length and increase the receiver IFOV, and we installed a new focal plane assembly that locates the ten GEDI Receiver Fiber Optic Assemblies at their intended off-axis positions to achieve ten equally spaced ground tracks.

Figures 2a-c show the GEDI RTA optical layout. The telescope is made of I-220-H beryllium and uses a fast f/0.7, light-weighted primary to minimize the telescope length and mass. The fused silica, all spherical triplet lens assembly (Aft Optics Assembly) located right behind the primary mirror corrects for the Ritchey-Chretien telescope residual off-axis astigmatism and yields a curved focal plane; there is no need to flatten the field since the individual Receiver Fiber Optic

Assemblies defining the IFOVs can be independently focused. Finally, a set of small N-BK7 field lenses, near the telescope focal plane, reduces the telescope Effective Focal Length (EFL) from 3.6 m to 2.0 m. This is done in order to achieve a 300 μ rad diameter IFOV on each of the ten 600 μ dia., 0.22 numerical aperture (NA) multi-mode fused silica Receiver Fiber Optic Assemblies that are the receiver field stops. The position of each field lens was optimized to achieve the same IFOV on each channel using two slightly different field lens designs. The RTA optical design is telecentric and illuminates the Receiver Fiber Optic Assemblies normal to the fiber face at $f/2.5$, which provides angular alignment margin over the fiber-optic $f/2.3$ acceptance angle.

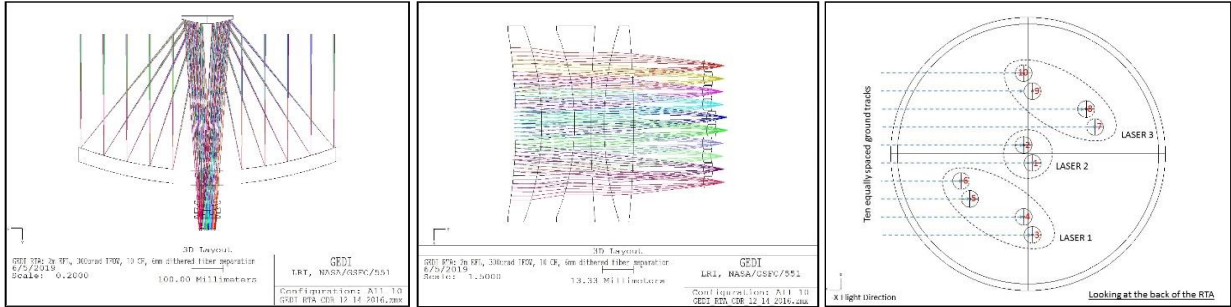

Figure 2a: RTA Optical Layout

Figure 2b: Aft-Optics Detail

Figure 2c: Focal Plane Arrangement

The Receiver Fiber Optic Assemblies, described in more detail in section 4.5, were manufactured in-house and use Diamond AVIM™ adapters and connectors (on the DM end of the fiber assembly), since they are space-qualified, have extensive heritage, and provide the tight opto-mechanical tolerances required to allow for fiber replacement without the need to re-align the system. The RTA focal plane includes ten independent custom fiber adapters that allow for a small amount of de-space (via shimming) and de-center adjustment in order to optimize focus and instrument-level boresight alignment; the fiber adapters are liquid pinned after final adjustment. There is no need to re-focus the RTA fiber adapters for vacuum operation since most of the RTA optical power is reflective. The RTA design is also athermal over a 20 ± 20 C bulk temperature operating environment, but we have to maintain the beryllium telescope axial and primary radial gradients to <2 C axial and <1 C radial given the 11.4 ppm/C coefficient of thermal expansion (CTE) of beryllium and the 46X longitudinal magnification of the Ritchey-Chretien telescope design.

The optical design for the GEDI DOA is based on previous designs flown on the Mercury Laser Altimeter (MLA)⁴ that also required multiple fiber optics imaged to a single 0.7 mm diameter Silicon Avalanche Photodiode (Si APD) detectors manufactured by Excelitas. In the case of GEDI, some DOA's have two Receiver Fiber Optic Assemblies, a Start Pulse Fiber Optic Assembly (to start the instrument clock that measure's time-of-flight to the ground and back), and a Ground Support Equipment (GSE) Fiber Optic Assembly for ground testing using simulated terrain return laser pulse shapes. The DOA optical design needs to accommodate four input fiber optics of different sizes and NA's, all of which need to be collimated, spectrally filtered to reject solar background on the receiver channels, and re-imaged onto a common detector with a 0.53mm diameter high-responsivity area. In addition, the DOAs start pulse channel, which samples some of the outgoing laser light, needs to allow for several orders of magnitude attenuation using neutral density (ND) filters to prevent detector saturation. Figures 3a&b shows two cross sections of the DOA optical layout including the detector element.

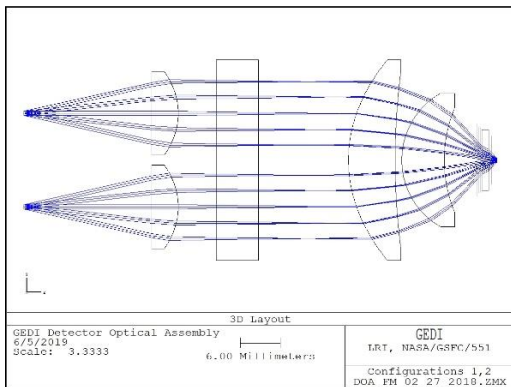

Figure 3a: DOA Optical Layout (receiver channels)

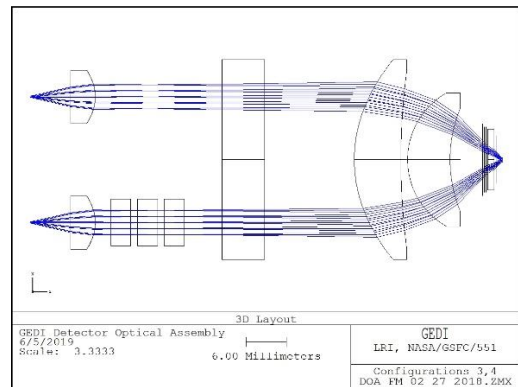

Figure 3b: DOA Optical Layout (GSE and start pulse channels)

The collimating lenses are commercial off-the-shelf (COTS) plano-convex aspheric lenses from Asphericon, while the focusing doublet consists of a modified Asphericon aspheric lens (the back has a concave radius as opposed to being flat) and a custom designed, high index, spherical meniscus lens. All four input fibers are imaged to a 0.4 mm dia. area at the detector center at a final marginal ray illumination speed of $f/0.7$. The 30 mm diameter bandpass filter was manufactured by Alluxa and has a 1064.2 nm center wavelength, a 0.7 nm FWHM, and blocking $> 10E5$ average over the detector spectral response range of 300 to 1200nm. One part of the DOA development that proved particularly complicated, was screening the bandpass filters for uniformity across their aperture since the four channels illuminate different filter aperture areas (see section 4.6 for testing). Although this is a fast refractive design, the end-to-end performance is insensitive to pressure given that the lenses have a high-index of refraction and that we are imaging an extended source. With the optics mounted in a titanium lens barrel, the system imaging performance is also insensitive to its operating temperature range of 10-40 C. The filter center wavelength thermal sensitivity is very small (4.2 pm/C) and negligible.

Figures 4a&b shows the DOA opto-mechanical design and its modularity to allow for ease of integration and test. The Alignment of the Collimating Lens Assembly and the Detector Lens Assembly occurred independently prior to mating the two units and the verification of end-to-end alignment. For the Collimating Lens Assembly, the fiber adapters are shimmed to collimate all four beams and the adapters were de-centered to make all four beams normal to the sub-assembly interface flange (tolerance was tightly controlled to the filter internal mounting lip such that the filter and sub-assembly interface flange are very nearly parallel). Then we used the same alignment telescope set at focus infinity for 1064nm and aligned perpendicular to the Detector Lens Assembly interface flange in order to focus (by shimming) and de-center the detector such that its image is focused at infinity (i.e. collimated) and centered on the alignment telescope reticle (which is viewed by a camera). When the two DOA sub-assemblies are mated, we would expect that all four fiber images would be centered and well-focused on the detector. We confirmed this alignment at the DOA to DM assembly level by illuminating one installed GSE test fiber at a time and viewed the detector illumination through the other three fiber adapter ports as described and shown in section 4.6. The final part of the DOA development was to set the start pulse attenuation filters. This was done in conjunction with the laser subassemblies by measuring the start pulse output power, calculating a nominal set of ND filters, integrating and measuring the detector response, and then adjusting the attenuation level to achieve the desired response. The DOA opto-mechanical design allows for the removal of the ND filter stack without losing the previously set alignment between the Start Pulse Fiber Assembly and the detector for final attenuation adjustment during final optical system integration.

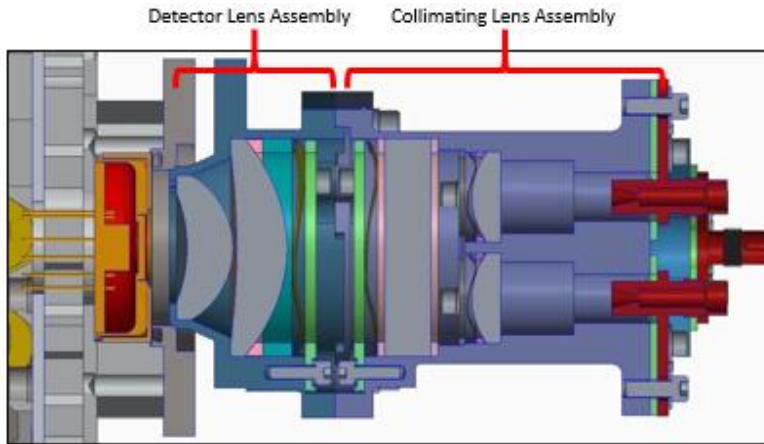

Figure 4a: DOA Assembly Opto-Mechanical Design

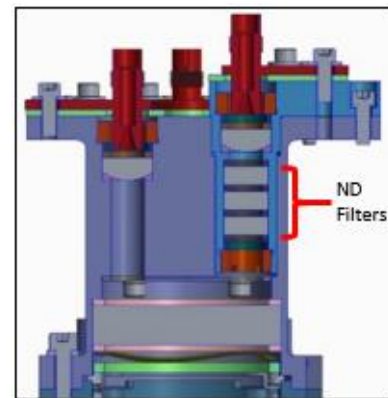

Figure 4b: Start Pulse ND Filter Subassembly

3.2 Transmitter Systems Optics

As mentioned before, each of the three GEDI Transmitter Systems includes the following optical components (see Figure 5): Laser, BDU, Fold Mirror, Beam Expander, DOE (originally part of two transmitter systems designs), and a BAM. The clocking angle of the BDU crystal, the Fold Mirror position and tip/tilt angle, the Beam Expander pointing angle, and the DOE clocking angle are unique to each transmitter path in order to generate ten equally spaced tracks on the ground that map to the ten laser footprints to the ten RTA IFOV's. All of these transmitter component alignment parameters work together to generate the required laser beam field angles as summarized in Figures 6a.

For all three Transmitter Systems, the beam converging angle between the S-pol. and P-pol. laser beam paths of the BDU crystal is 18.85 mrad. The Fold Mirror is used to align the axis that defines the center of the BDU output beam path parallel to the Beam Expander optical axis. The Beam Expander input lens is located where the two BDU beams overlap and the Beam Expander is tilted (for pointing to their corresponding off-axis RTA IFOVs) with respect to nadir except for the Transmitter System aligned to the on-axis RTA IFOV pair. Two of the Beam Expanders have the capability to include a DOE with a given diffraction angle and clocking angle to generate the four final outgoing beams. The DOE⁵, manufactured by Jenoptik, is an elegant, efficient, and alignment insensitive way to split an input laser beam into multiple copies propagating at specific angles/patterns. The final set of optics in the transmitter paths are the BAM Risley prisms, which provide a group Line-Of-Sight (LOS) adjustment of $\pm 2\text{mrad}$ for ground and on-orbit boresight alignment optimization. Note that the RTA IFOV channel numbers (Figure 2c) are flipped up/down and left/right compared to the laser channel numbers (Figure 6b) because the RTA flips the ground image.

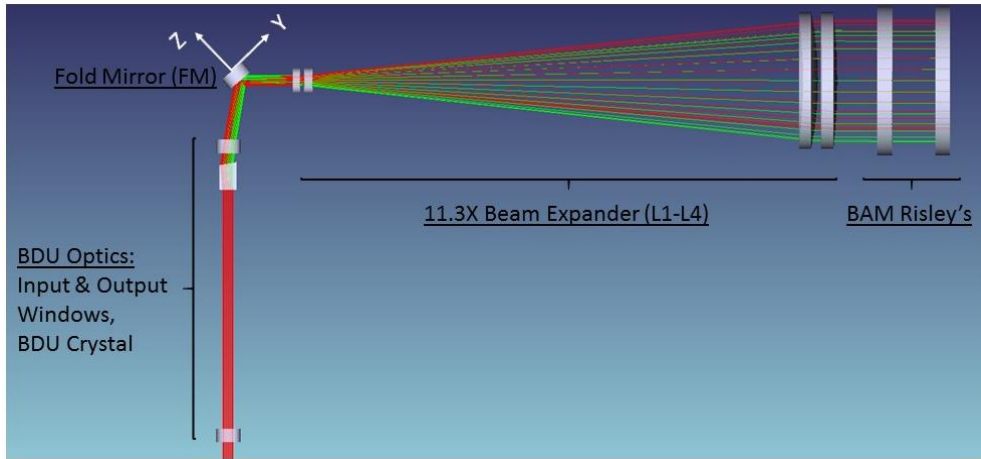

Figure 5: Transmitter Path Optical Components

Laser #	BDU Pol.	DOE Order	GEDI/Zemax	Zemax Field Angles (mrad)			Crosstrack Spacing	
				X-Axis	Y-axis	Radial	ΔX (mrad)	ΔX (m)
2	E-Ray		1	0.36501	0.74838	0.8326		
	O-Ray		2	-0.36501	-0.74838	0.8326	1.497	621.2
1	E-Ray	-1	3	0.36501	6.73542	6.7453	1.497	621.2
	O-Ray	-1	4	-0.36501	5.23866	5.2514	1.497	621.2
3	E-Ray	+1	5	-4.81799	3.74190	6.1004	1.497	621.2
	O-Ray	+1	6	-5.54801	2.24514	5.9851	1.497	621.2
3	E-Ray	-1	7	5.54801	-2.24514	5.9851	1.497	621.2
	O-Ray	-1	8	4.81799	-3.74190	6.1004	1.497	621.2
3	E-Ray	+1	9	0.36501	-5.23866	5.2514	1.497	621.2
	O-Ray	+1	10	-0.36501	-6.73542	6.7453	1.497	621.2

Figure 6a: GEDI Transmitter Field Angles

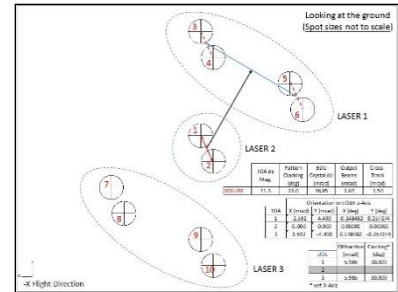

Figure 6b: Transmitter FOV and Element Vectors

The GEDI Transmitter System Beam Expanders provide the 11.3X afocal magnification to achieve the required outgoing laser beam divergence diameter of $50\text{-}60\mu\text{rad } 1/e^2$. The Beam Expander is a Galilean design based on the one flown on the Lunar Orbiter Laser Altimeter (LOLA)⁶, but modified with an additional element in the negative group to correct for coma since the beam expander is used slightly off-axis by the two beams from the BDU. Figure 7 shows a layout of the Beam Expander. Part of the design effort included making sure that ghosting from the Beam Expander lenses did not re-focus on any optic in the transmitter optical train. The Beam Expander optics are integrated in a titanium tube to minimize thermal sensitivity, but the Beam Expanders do need to be re-focused (via a shim change) for vacuum operation. Two of the three Beam Expanders were designed to have DOE's at their output, but in the end, we flew only one DOE when we de-scoped from ten to eight beams. Removing the DOE also required repointing the Beam Expander with respect to the Optical Bench (via a custom wedged shim) to aim that one Transmitter Systems beams at the two selected RTA IFOV's within that original corresponding group.

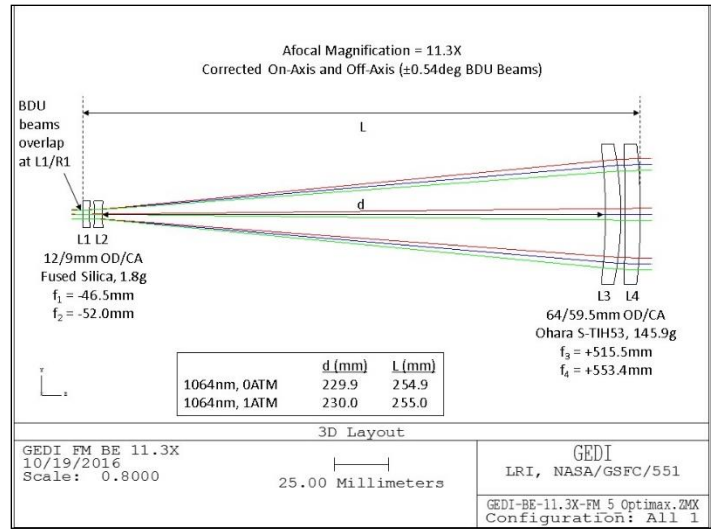

Figure 7: Laser Beam Expander Optical Layout (DOE not shown)

3.3 System Level Model

Given the complexity of GEDI, we generated a system level optical model that matched the instrument mechanical configuration and included all relevant optics from the Transmitter and Receiver Systems (Figure 8). A raytrace of each laser source verified that all the transmitter optics alignment parameters specified were correct and led to each transmitter channel illuminating its corresponding receiver channel at the RTA focal plane. To simulate the ground return, we folded the transmitter back into the receiver using three ideal Lateral Transfer Retroreflectors (LTR's). This is the scheme we used on previous space-based laser altimeters to verify system level boresight alignment during instrument level Thermal Vacuum (TVAC) testing as well as on GEDI TVAC testing. The system level optical modeling effort was well worth it because we discovered that our preliminary design for the RTA focal plane was a mirror image of what it needed to be!

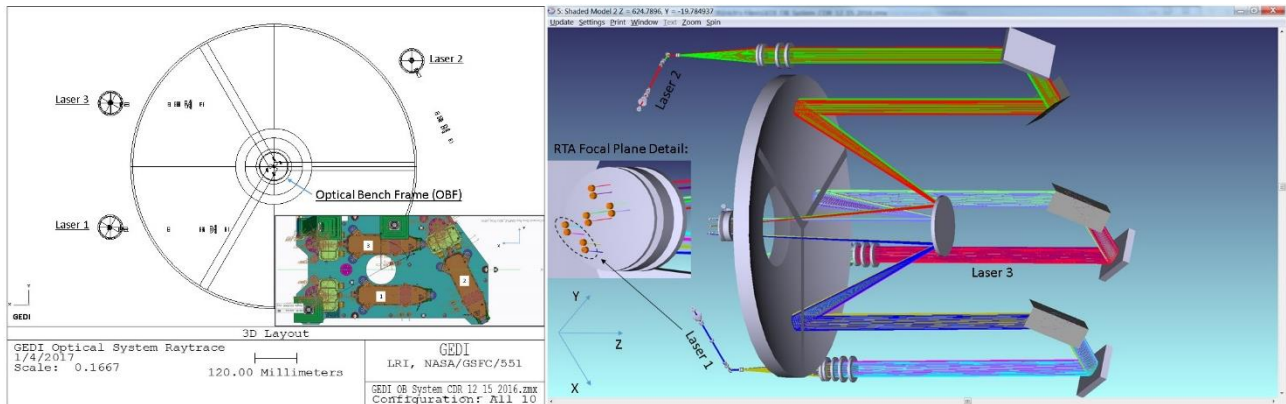

Figure 8: GEDI System Level Optical Model

4. SUBSYSTEM DEVELOPMENT

4.1 Beam Dithering Unit

The Beam Dithering Unit (BDU) is an electro-optical beam steering unit that alters the pointing of the laser beam without relying on mechanical motion. The lack of an internal mechanism results in a highly reliable unit with very stable output beams. The BDU is a sealed and pressurized enclosure with all necessary optical components and an electrical driver board inside. The optical components are mounted on a small optical bench inside the enclosure to maintain alignment and assist with assembly. Optical components include a pair of Pockels cells, a waveplate, and a birefringent crystal. Polarized laser light enters the unit through a window on the enclosure. The polarization is altered by applying voltage on the Pockels

cells, which changes the angle of the light inside the birefringent crystal. Changing the angle of the transmitted laser pulse as it enters the GEDI beam expander results in a translation of the spots in the far field. Synchronizing the timing of the laser and BDU allows generation of distinct ground tracks on the earth. The BDU was conceived, developed and flight qualified at GSFC.

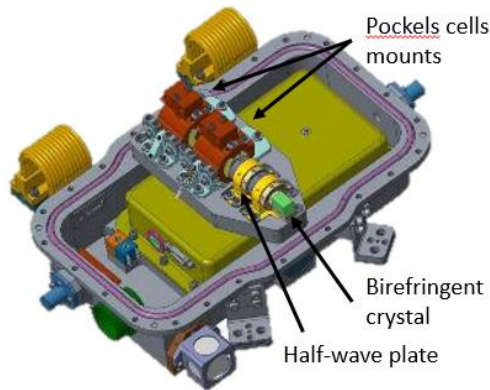

Figure 9a: Lid off BDU Model

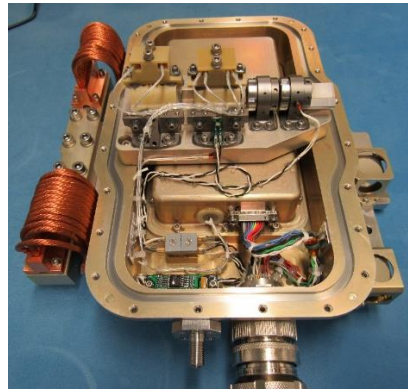

Figure 9b: Lid off Flight BDU



Figure 9c: Flight BDU

4.2 Transmitter Beam Expander Assemblies

Spacing between negative and positive lens groups in each Beam Expander is critical to achieve desired output beam diameter and divergence. The calculated nominal air lens spacing was verified by measuring beam diameter and divergence of the far-field output from each assembled Beam Expander using a 2.5 m focal length parabolic mirror and a beam-profiling camera. Figure 10a shows part of the test setup. This same test methodology was used to verify beam diameter and divergence for the smaller beam expanders installed inside the GEDI laser assemblies. In addition, angular magnification was measured for each assembled Beam Expander using theodolites as shown in Figure 10b.

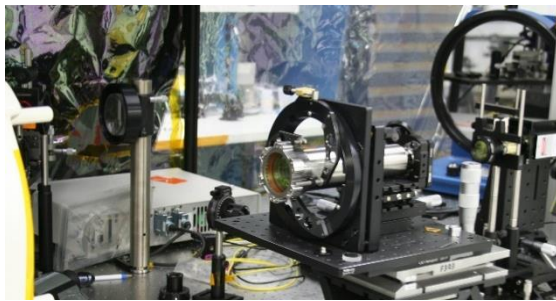

Figure 10a: Far-Field Testing of the Beam Expander

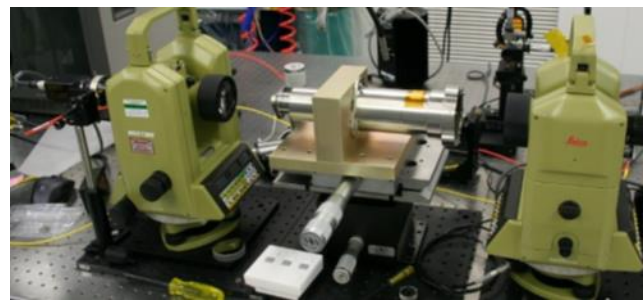

Figure 10b: Beam Expander Angular Magnification Measurement

After corroborating analytical air spacing with measured results, a lens spacing adjustment was installed on each beam expander to account for optimal vacuum alignment. Output beam diameter and divergence were measured under vacuum to verify the 11.3X magnification and 50-60 μrad 1/e² divergence requirement. Angular measurements were taken using theodolites, autocollimators, and reference flats to correlate the optical axis of each beam expander to its own mounting fixture. The first lenses plano surface of the Beam Expander was used as its optical axis reference surface. These angular reference measurements were taken before and after vibration and thermal testing to monitor for physical changes in each Beam Expander.

4.3 Optical Fiber Hermetic Laser Feedthrough Assembly

Each laser has a custom fiber optic (600 μm core diameter with 0.22 NA) hermetic feedthrough to allow pickoff of the laser pulse for start-pulse timing determination. The feedthroughs and all GEDI fiber optic assemblies were designed, manufactured, and tested by the NASA Goddard's 562 Photonics Group who specialize in production of high reliability custom optical fiber components⁷. The start pulse system utilized the small amount of leakage light from the laser cavity to reflect off a diffuse surface into the fiber feedthrough. This resulted in a very rugged (alignment insensitive) method of generating the optical start pulses. The custom feedthrough allowed adjustment of the fiber end-face position during the flight build, to provide a coarse setting of the optical intensity transmitted from the laser to the detectors. Fine-tuning of

the optical start pulse intensity was done at the DOA, as described previously, with ND filters. The lasers are enclosed in a pressurized housing, which meant that the start pulse fiber feedthroughs had to meet the leak rate requirements, survive all environmental requirements, while not stressing the optical fibers and altering the transmitted light. We utilized multiple sealing methods in various portions of the feedthrough to ensure a hermetic seal over the relevant spaceflight environments without stressing the fibers and resulting in a reduction in reliability.

4.4 Start Pulse Fiber Optic Assemblies

Optical pulses from the laser feedthrough assembly were then coupled to a custom triple optical fiber bundle array inside of a custom Diamond AVIM™ connector as shown in Figure 11. These Start Pulse Fiber Optic Assemblies were fabricated with Polymicro/Molex (200 μm core diameter with 0.22 NA) optical fiber and upjacketed with W.L.Gore FlexLite™ cable. The triple array fans out to three individual assemblies each terminated with a Diamond AVIM connector. The fan-out side routed the start pulses to the DOA's and the Bench Checkout Equipment (BCE) test system. All assemblies were fabricated using space flight practices; 100% inspection of piece parts, testing/ preconditioning of all non-metallic materials to comply with contamination requirements and to maintain packaging integrity. The packaging design was validated using thermal cycle testing and in situ transmission monitoring.

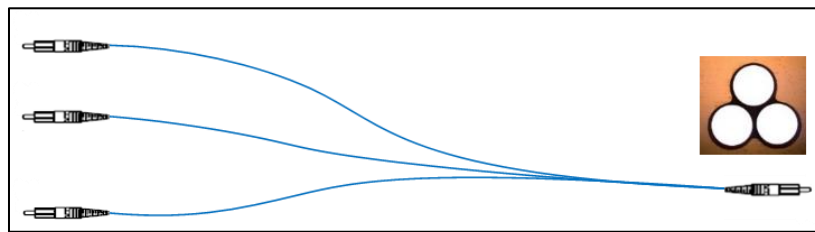

Figure 11: Start Pulse Fiber Optic Assembly

4.5 Receiver Fiber Optic Assemblies and Custom RTA Interface

The Receiver Fiber Optic Assemblies were fabricated with Polymicro/Molex (600 μm core diameter with 0.22 NA) optical fiber and upjacketed with W.L.Gore FlexLite™. These assemblies required greater than 97% transmission at 1064 nm and were anti-reflection (AR) coated. Standard space flight practices were applied to fabricate these assemblies including 100% concentricity inspection of all connector ferrules. Absolute optical transmission for each assembly was verified using the same source injection conditions as the RTA. The expected radiation end of life attenuation was extrapolated from the LOLA optical fiber radiation test data⁸. The expected loss was calculated as less than 0.04% at the end of a 2 year mission lifetime with a 3 Krad/year dose rate.

The Receiver Fiber Optic Assemblies were terminated with Diamond AVIM™ connector at the DOA interface end. The other end was custom to interface with the RTA as can be seen in Figure 12a. This interface required close placement between pairs of the receiver fiber optics at the RTA focal plane and could not accommodate a typical off-the-shelf connector as shown in 12b. The design was based on a James Webb Space Telescope (JWST) GSE design⁹ and it underwent a flight qualification program with environmental testing. These fiber optic assemblies are the largest (by core diameter) known flown in space by NASA. The large diameter core restricted tightness of bend radius and therefore, the routing scheme. The routing required a custom tray to guide and retain these fibers. Figure 12c shows the routing and installation of these fibers along with the Start Pulse Fiber Optic Assemblies.



Figure 12a: Fibers installed to RTA

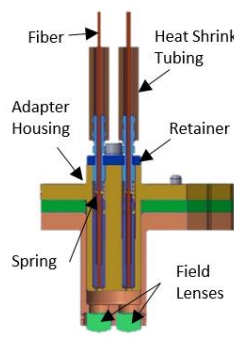

Figure 12b: Fiber Interface Assembly



Figure 12c: Fiber Integration

4.6 Detector Optical Assemblies

A critical alignment parameter for the detector assembly is the lateral and focus positioning of each input fiber. Correct fiber to the first lens spacing collimates light and lateral positioning of fiber ensures normal incidence on the dielectric bandpass filter. Utilizing a GSE test fiber, the adapter was adjusted until light output from each test fiber was in focus and aligned to bandpass filter angular return on an autocollimator as shown in Figure 13a. The shim spacing between the Detector Optical Assembly (DOA) and the detector is also important. Each off-axis channel shares the same focal plane and 0.4 mm image size at the detector. The shim spacing was adjusted and the image plane was observed with a microscope through each open fiber channel. 1064 nm laser light was sent through the GSE test fiber and it illuminated the SiAPD detector through each fiber channel while viewed with microscope. The shim spacing was correct when each fiber channel was centered and under-filled the 0.7 mm diameter SiAPD detector as shown in Figure 13b. These alignment images were captured before and after vibration and thermal testing to monitor for any physical changes.

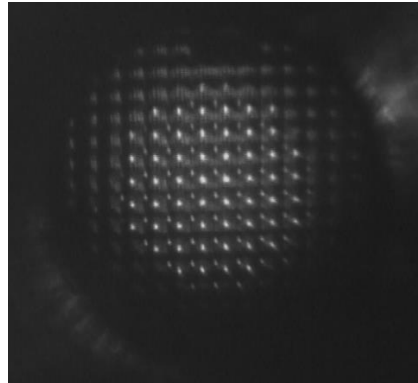
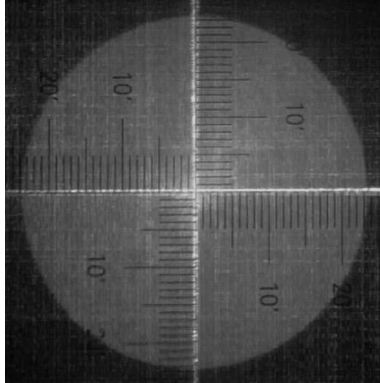

Figure 13a: Fiber channel output aligned to angular filter return

Figure 13b: Fiber channel output focused & centered on detector

The dielectric bandpass filter is the only spectral filtering element in the GEDI Receiver System and therefore, required extensive measurements to verify transmission, spectral bandwidth, center wavelength of bandwidth, and performance uniformity across the filter. To measure these parameters, collimated output from a temperature-tuned narrow linewidth Distributed Feedback (DFB) laser diode was used as a test source allowing for picometer level adjustment of source wavelength. The source was angularly aligned to the surface of the filter using an autocollimator to ensure normal incidence. A wavemeter measured output wavelength with sub-picometer accuracy while a silicon test detector measured transmission as shown in the testbed in Figure 14a. Transmission was measured as a function of wavelength at various positions across the aperture of each filter. Figure 14b shows an example of this data for one position on a filter.

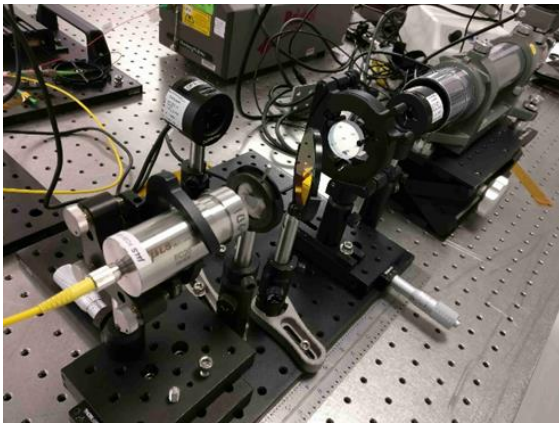

Figure 14a: Filter transmission vs wavelength test setup

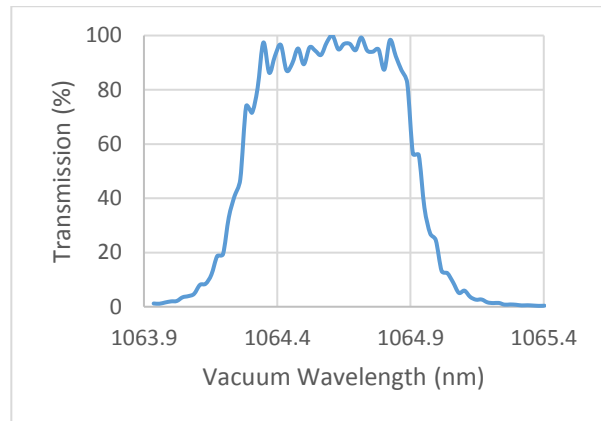

Figure 14b: Filter transmission vs wavelength results

5. OPTICAL INTEGRATION, ALIGNMENT, AND TESTING

All GEDI transmitter and receiver subsystem components, except the DMs, were installed and aligned on the Optical Bench (OB) in the GEDI cleanroom facility. The fiber coupled DMs were installed directly into the GEDI Box Structure, and no system level optical alignment is required. An overview of the Optical Integration, alignment, and testing is presented here as a more detailed process is presented in another paper¹⁰.

The GEDI OB was fabricated at GSFC and consists of an aluminum core with composite panels epoxied to the core. This structural panel was machined to accommodate titanium fittings that allow integration of the instrument components on the OB. The primary datum that defines the GEDI coordinate system is the RTA interface plane defined by the three pads and pins that the RTA interfaces to on the OB. The GEDI OB coordinate system was established during Coordinate Measuring Machine (CMM) characterization at GSFC using the RTA interface datum normal to establish the Z axis. Before delivery, every subsystem to be installed on the OB underwent metrology that provided information about the position of the optical beam centroid exiting the subsystem, as well as the pointing of the beam. Laser Tracker metrology and CAD model information provided the beam position in OB coordinate system.

The first component to be installed on the OB was the RTA via three inserts with pins. The origin of the OB Mechanical Reference Frame is defined as the center of the RTA pins circle, through which the optical axis (Z) of the telescope passes. The raised bosses on the three RTA OB inserts define the XY plane. As the RTA is used in defining the coordinate system, all other components are aligned to this, such that the RTA does not need to be repositioned once installed. The three lasers on the GEDI Instrument are installed on the $-Z$ side of the OB, as previously shown in Figure 1. To optimize integration and test flow, the lasers were delivered and aligned one at a time after they completed environmental testing¹¹. Each of the individual subsystems that make up the Transmitter System, were delivered to OB integration after their individual ambient and environmental testing was complete. Alignment of each Transmitter System began with inter-alignment of the laser and BDU components in order to optimize polarization dependent performance. Subsequently, the Fold Mirror then the Beam Expander were installed and aligned using the collimator.

A 1-m diameter collimator was used as the key element in the GEDI transmitter to receiver alignment. A 5 m EFL on-axis parabola was located (optical axis horizontal) at the end of the GEDI cleanroom facility. A flat fold mirror was positioned about 4 m in front of the parabolic mirror and angled at 45 degrees in order to fold the collimators focus position out of the optical path between the collimator and GEDI. At the collimator focus, a Basler camera resided on an optical table, which was referred to as the collimator camera. The camera has a FOV that allowed one pair of field points to be viewed at a time. See figure 15 for this test setup.



Figure 15: GEDI collimator setup with the GEDI Optical Bench on a white GSE dolly

By back illuminating the RTA via injecting light into the GEDI Receiver Fiber Optic Assemblies, collimated beams were transmitted out through the telescope towards the large parabolic primary collimator mirror. This back-illumination projected the 300 μrad diameter IFOVs onto the collimator camera. In order to align the transmitter to the receiver, the transmitted beams from each Transmitter System were sent into the collimator as well, and the transmitter beams were displayed by the same camera at the collimators focus. Attenuation of the transmitter beams was achieved by a using a slab beamsplitter to send the majority of the light into a power meter and using ND filters to set the intensity of the passed beam. The angular deviation of the beamsplitter and ND filters were tightly controlled in order not to bias the pointing of the transmitted beams by more than 20 μrad . The collimator camera had a FOV of about 2100 μrad x 2100 μrad , and once the transmitter beams were located onto the camera with the back-illuminated receiver IFOVs, the work to actively co-

center the beam image pairs occurred. This was achieved by manually adjusting the positions of the IFOVs (via adjusting the Fiber Interface Assemblies) at the RTA focal plane. Manual adjustment of the DOE was required for the Transmitter System with the DOE. The collimator camera provided excellent visual feedback during alignment, with the images easily distinguishable, due to the differences in size and brightness of the transmitted beams (small, bright) versus the back-illuminated receiver images (large, dimmer). Figure 16 shows an example of a pair of beams aligned and imaged with the collimator camera.

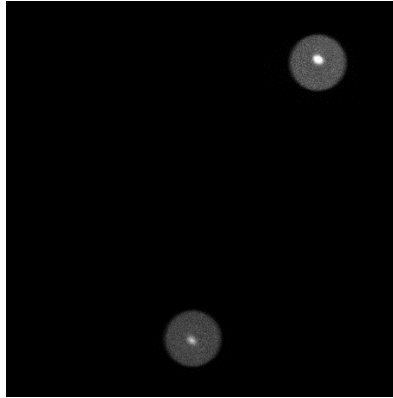

Figure 16: Smaller, bright transmitter beam pair aligned to the center of the large, dim, back-illuminated receiver IFOV pair

The goal was to minimize the amount of boresight adjustment to be implemented via the BAMs Risley prisms. 1 mrad of the total 2 mrad provided by the GEDI BAM, was allocated to the optical boresight alignment, however, the philosophy was that the optical boresight alignment would be performed to the best alignment possible before the BAM range was used. This provided more range for on-orbit correction, if needed. The installation and adjustment of the BAMs, and subsequent full end-to-end test in the collimator of all transmitter to receiver alignment, concluded the optical flight hardware installation and initial alignment. The GEDI instrument then underwent an environmental test campaign with alignment re-measured before and after every test. During the TVAC test, a custom designed target assembly monitored the health of the laser, the transmitter beam divergence and power, and aided in the transmitter to receiver boresight alignment. This target assembly is known as the Bench Checkout Equipment (BCE).

Table 1 shows the shifts measured over environmental testing and after launch during the initial commissioning activities aboard the ISS. The environmental testing changes were performed with aid from the BCE and the launch changes were performed on orbit. The launch changes listed in the table include gravity release effects. These values were determined by monitoring detector response as the BAMs moved the transmitted beams in and out of alignment at a known distance and then calculating the center of the response in two axes.

Table 1: Table of Boresight Shifts

Path	Environmental Testing Change	Launch Change
TX 1	80 μ rad	100 μ rad
TX 2	70 μ rad	110 μ rad
TX 3	75 μ rad	95 μ rad

Figure 17 shows an example plot generated from on orbit alignment data of a single transmitted beam to its corresponding receiver IFOV. The noise visible is from data being collected on orbit with real surface returns of varying properties. The goal is to collect the data over uniform targets, but real world conditions (clouds for example) limit uniformity of targets returned intensity, and thus accuracy ($\sim 30 \mu$ rad). When possible, the measurements are repeated for statistical noise reduction and increased confidence in knowledge of transmitter to receiver relative alignment. System modeling predicted realignment would rarely be required and this has been confirmed with on orbit performance. Since commissioning alignment concluded (over 4 months prior to writing this paper) no realignment has been required.

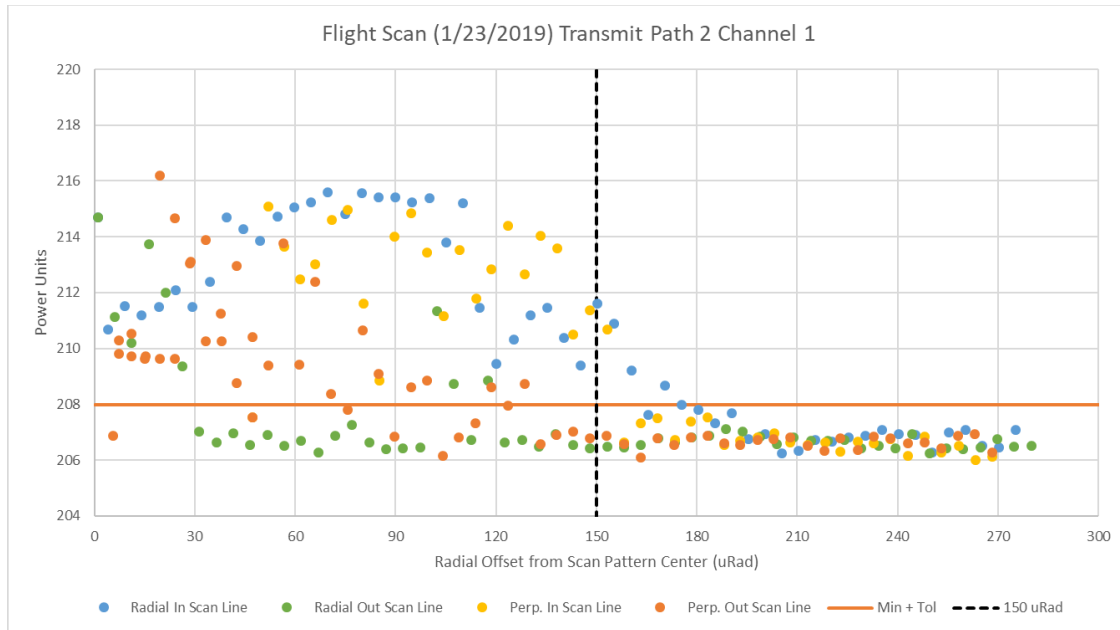

Figure 17: Example of Detector Response vs. Position

6. CONCLUSION

This paper presented the optical system design, subsystems utilized, and an overview of the optical alignment and integration of GEDI, a multi-beam waveform LiDAR instrument built at NASA's GSFC. From an optical systems perspective, GEDI is one of the most complex NASA LiDAR systems successfully flown in space due to multiple transmitters co-aligned to a single receiver with multiple sampling channels. GEDI was an aggressive, fixed budget development effort with optical bench alignment and integration completed in April 2018. Instrument environmental testing concluded in September 2018 and GEDI launched to the ISS on December 5, 2018.

Figure 18a shows GEDI prior to Thermal Vacuum testing and Figure 18b shows GEDI installed on the ISS. Science operations began March 2019. As of writing this paper, GEDI has collected over a billion science quality measurements, reaching the missions measurement quantity baseline science requirement.

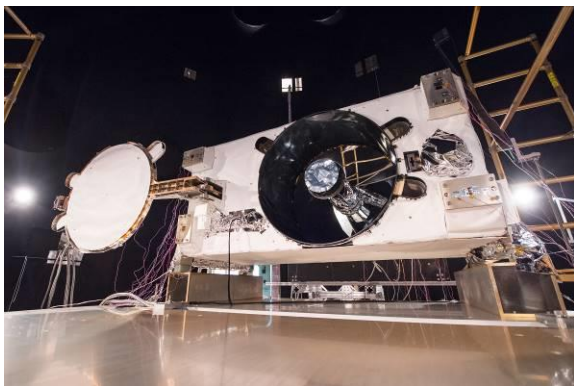

Figure 18a: GEDI ready for TVAC testing

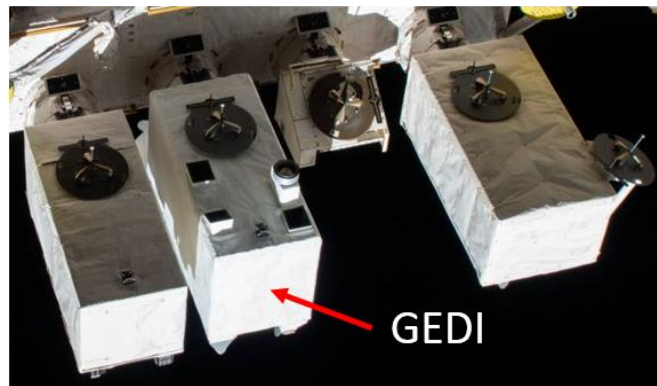

Figure 18b: GEDI installed on ISS JEM-EF

Many NASA GSFC individuals contributed greatly to the success of GEDI. Without their dedication, none of this work presented would have been possible. In particular, we would like to thank Dr. Ralph Dubayah (GEDI PI), James Pontius (GEDI PM), Keith Walyus, Cheryl Salerno, Taylor Hale, Miles Smith, Alexia Harper, Brian Simpson, Robert Chalmers, Kevin Hughes, Brian Simpson, Alexander Schaeffer, Eric Norris, Richard Gore, Christina Ross, Michael Kang, Ichung Weng, Haiping Song, Patrick Thompson, Dennis Skelton, and Jordan Thompson, Eleanya Onuma, and Rick Chuska.

REFERENCES

- [1] Dubayah, R., “Global Ecosystem Dynamics Investigation,” University of Maryland, <https://gedi.umd.edu>.
- [2] Coyle, D. B., Stysley, P. R., Poullos, D., Frese, E. A., Chirag, F. L., “The Global Ecosystem Dynamics Investigation (GEDI) LiDAR laser transmitter,” Proc, SPIE 11128, Infrared Remote Sensing and Instrumentation XXVII (2019).
- [3] Hagopian, J., Bolcar, M., Chambers, V. J., Crane, A., Eegholm, B., Evans, T., Hetherington, S., Mentzel, E., Thompson, P., Ramos-Izquierdo, L., Vaughnn, D., “Advanced Topographic Laser Altimeter (ATLAS) Receiver Telescope Assembly (RTA) and Transmitter Alignment and Test”, Proc. of SPIE 9972, Earth Observing Systems XXI, 997207 (2016).
- [4] Ramos-Izquierdo, L., Scott III, V. S., Schmidt, S., Britt, J., Mamakos, W., Trunzo, R., Cavanaugh, J., Miller, R., “Optical System Design and Integration of the Mercury Laser Altimeter”, Applied Optics, Vol. 44 No. 9, (2005).
- [5] Smith, J.G., Ramos-Izquierdo, L., Stockham, A., Scott III, V. S., “Diffractive Optics for Moon Topography Mapping”, Proc. of SPIE, Vol. 6871, 622304 (2006).
- [6] Ramos-Izquierdo, L., Scott III, V. S., Connelly, J., Schmidt, S., Mamakos, W., Guzek, J., Peters, C., Liiva, P., Rodriguez, M., Cavanaugh, J., Riris, H., “Optical System Design and Integration of the Lunar Orbiter Laser Altimeter”, Applied Optics, Vol. 48 No. 16, (2009).
- [7] Ott, M., “Photonics Group,” NASA GSFC, <https://photonics.gsfc.nasa.gov>.
- [8] Jin, X., Ott, M. N., LaRocca, F. V., Chuska, R. F., Schmidt, S. M., Matzuseski, A. J., Macmurphy, S. L., Thomes., W. J., Switzer, R. C., “Space Flight Qualification on a Novel Five-fiber Array Assembly for the Lunar Orbiter Laser Altimeter (LOLA) at NASA Goddard Space Flight Center,” Proc, SPIE 6713, Nanophotonics and Macrophotonics for Space Environments, 67130S (2007).
- [9] Thomes, W. J., Ott, M. N., Chuska, R. F., Switzer, R. C., Onuma, E., Blair, D., Frese, E., Matyseck, M., “Cryogenic fiber optic assemblies for spaceflight environments: design, manufacturing, testing, and integration”, Proc, SPIE 9981, Planetary Defense and Space Environment Applications, 99810F (2016).
- [10] Eegholm, B. H., Wake, S. W., Denny, Z. H., Dogoda, P., Poullos, D., Coyle, D. B., Mule, P., Hagopian, J. G., Ramos-Izquierdo, L., Blair, J. B., “Global Ecosystem Dynamics Investigation (GEDI) instrument alignment and test,” Proc, SPIC 11103, Optical Modeling and System Alignment, (2019).
- [11] Stysley, P. R., Coyle, D. B., Chiragh, F., Frese, E., Hersh, M., Smith, K., Blalock, G., Morey, P., Lander, J., Kay, R. B., Poullos, D., Clarke, G. B., Washington, K., Kirchner, C., Mule, P., “Qualification of the solid state laser systems for the GEDI altimeter mission,” Proc, SPIE 10636, Laser Radar Technology and Applications XXIII, 106360U (2018).