

# Plant Water Management (PWM) Experiment



Joint CSA/ESA/JAXA/NASA  
Increments 61 and 62  
Science Symposium

17-18 September 2019

Tyler Hatch  
Deputy Project Scientist  
NASA Glenn Research Center

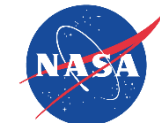

# PWM Team Contacts

## SCIENCE

Name	Role	Affiliation	Email
Dr. Mark Weislogel	Principal Investigator	Portland State University	<a href="mailto:mmw@cecs.pdx.edu">mmw@cecs.pdx.edu</a>
John McQuillen	SLSPRA Fluid Physics Discipline Lead	NASA	<a href="mailto:john.b.mcquillen@nasa.gov">john.b.mcquillen@nasa.gov</a>
Dr. David Chao	Project Scientist	NASA	<a href="mailto:david.f.chao@nasa.gov">david.f.chao@nasa.gov</a>
Tyler Hatch	Deputy Project Scientist	NASA	<a href="mailto:tyler.r.hatch@nasa.gov">tyler.r.hatch@nasa.gov</a>

## MANAGEMENT

Name	Role	Affiliation	Email
Kelly Bailey	Project Manager	NASA	<a href="mailto:kelly.a.bailey@nasa.gov">kelly.a.bailey@nasa.gov</a>
Bradford Martin	Project Manager	Zin Technologies, Inc.	<a href="mailto:martinb@zin-tech.com">martinb@zin-tech.com</a>



# PWM Project Team

## ***SCIENCE AND MANAGEMENT***

---

Kelly Bailey – NASA GRC PM  
Bradford Martin – Project Manager, ZIN  
Mark Weislogel – PI, PSU  
Rihana Mungin, Graduate Student, PSU

John McQuillen – Fluids Discipline Lead, NASA  
David Chao – Project Scientist, NASA  
Tyler Hatch – Deputy Project Scientist, NASA

## ***ENGINEERING***

---

Emily Griffin – Systems/Operations, ZIN  
CY Wo – Mechanical Engineer, ZIN  
Aaron Coe – Design Engineer, ZIN  
Brandon Wagner – Systems/Integration, ZIN

Al Linne – NASA Chief Engineer's Office  
David Fuller – NASA Systems Engineering

## ***SAFETY AND MISSION ASSURANCE***

---

Dave Bittner – NASA Safety, Reliability and QA  
Brian Loucks – Quality Oversight, Leidos  
Chris Bodzioney – Safety Engineer, ZIN

Nechelle Grant - Risk Management, Bastion  
Debra Lyden - Safety and Quality Manager, ZIN  
Dan Williston – Quality Assurance, ZIN



# Science Background

## **NASA's Plant Water Management Challenges**

- Plant watering complicated by the absence of gravity: aeration (gas/fluid interactions), diffusion of nutrient solution, and root growth.
- The specific needs at any point in time can vary based on the life cycle of the plant, from germination through harvest.
- Prior experiments have seen unexpected water migration due to surface tension forces, and poor aeration of the soil.
- Looking for simple, robust methods for advanced systems.

# Significance of Fluids Management

***Virtually all major systems involve fluids management  
(or mis-management)***

- Physical sciences research on ISS provides the knowledge base for designing systems, ISS provides a platform to validate technologies for inclusion in flagship missions.

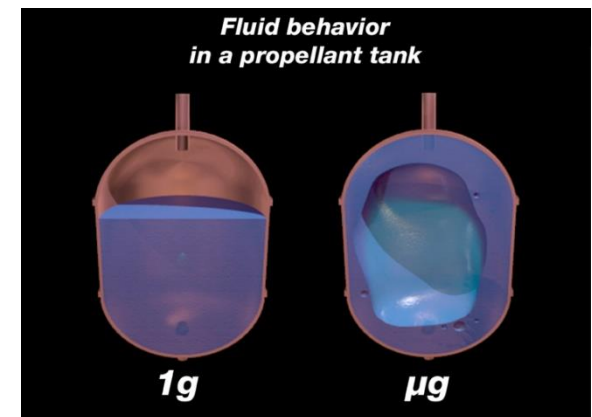
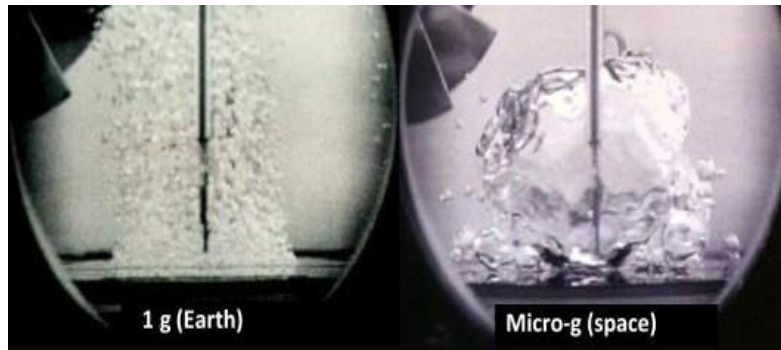



# PWM Science Objectives

- Demonstrate ability to provide hydration and aeration to plant root zone throughout the plant life cycle from germination through harvest
- Demonstrate ability to provide hydration and aeration to plant root zone for single plant chambers or multiple plant production chambers
- Demonstrate ability to control liquid inventory via capillary forces within either in an open container and/or a container with semi-permeable covers
- Demonstrate an ability to provide sufficient hydration commensurate with plant growth and evapotranspiration rates
- Demonstrate ability to provide hydration and aeration to plant root zone in a geometry that can be utilized in both a normal and microgravity environment
- Demonstrate routine priming, startup, shutdown, steady and transient operation

**PWM is a *Technology Demonstration* of recent advances in micro-g capillary fluidics research applied to plant growth systems**



# PWM Approach

## Watering Schemes and Factors:

1. Soil
2. Hydroponics
3. Root Accommodation Zone
4. Parallel Hydroponic Trays
5. Capillary Based Degassing and Liquid Aeration
6. Humidified Root Zone

## Test Facility:

- Maintenance Work Area (MWA) on ISS
- Crew Involvement
  - Setup
  - Priming
  - Adjusting Flow Rates
  - Dispose of hardware after use
- Data Analysis based on Downlinked Images

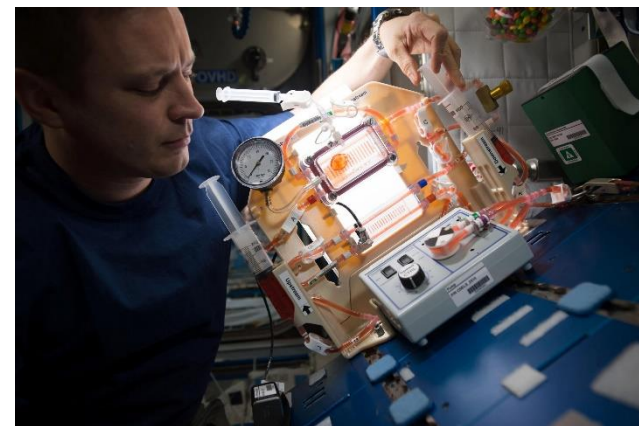



# PWM 1 (Soil)

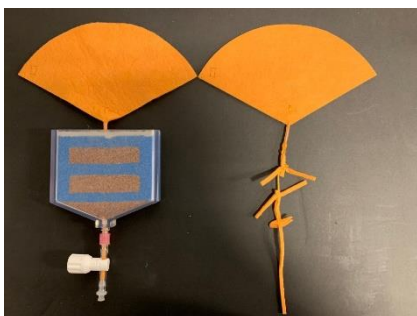

# PWM 2 (Hydroponics)

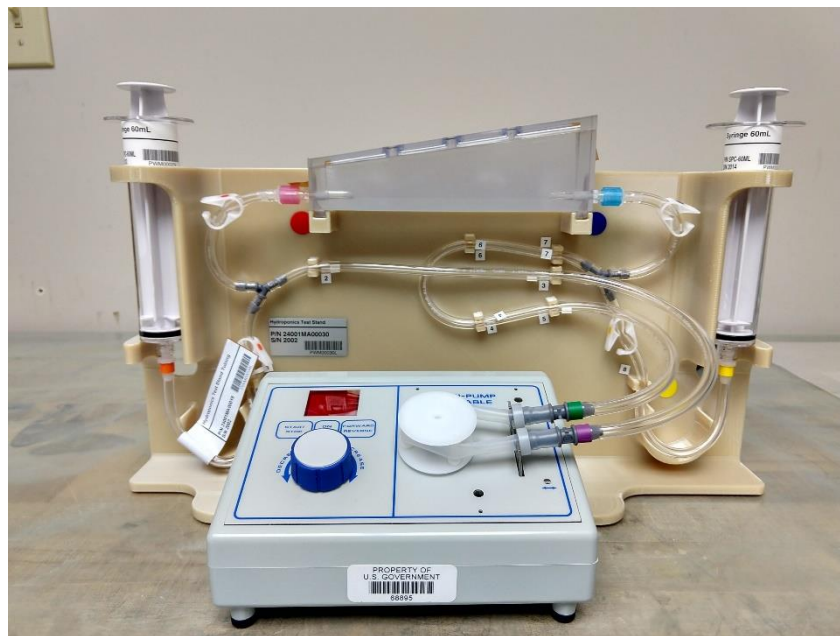



# PWM Soil

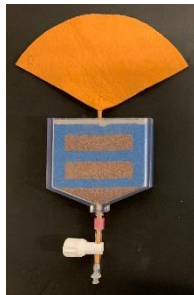
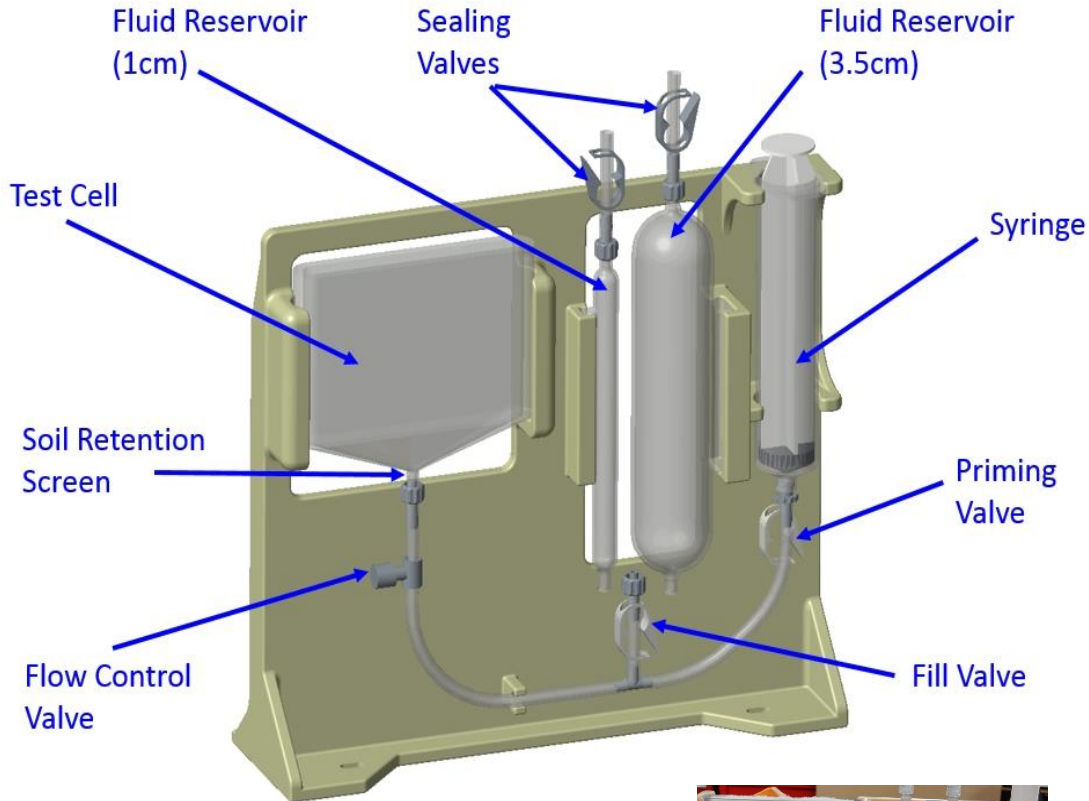

Component	Material
Test Stand	Ultem (3D Printed SLA)
Test Cell	Accura 60 (3D Printed SLA)
Test Fluid	ISS potable water mixed with Kool Aid® Tropical Punch (from the ISS On-orbit food pantry)
Plant Simulant	Rayon Felt/Nylon String Composite
Soil Simulant	Arcilite / Magic Sand
Soil Retention Screen	Rayon Felt Plug
Fluid Reservoirs	Accura 60 (3D Printed SLA)
Syringe	COTS Plastic, Luer
Fluid Lines	COTS Tygon
Fittings and Valves	COTS Plastic, Noncontact Pinch Style, Luer

# PWM Hydroponics

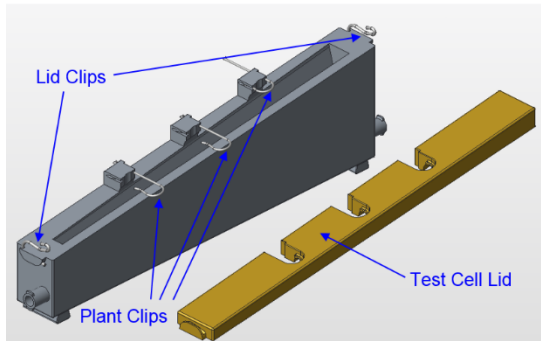
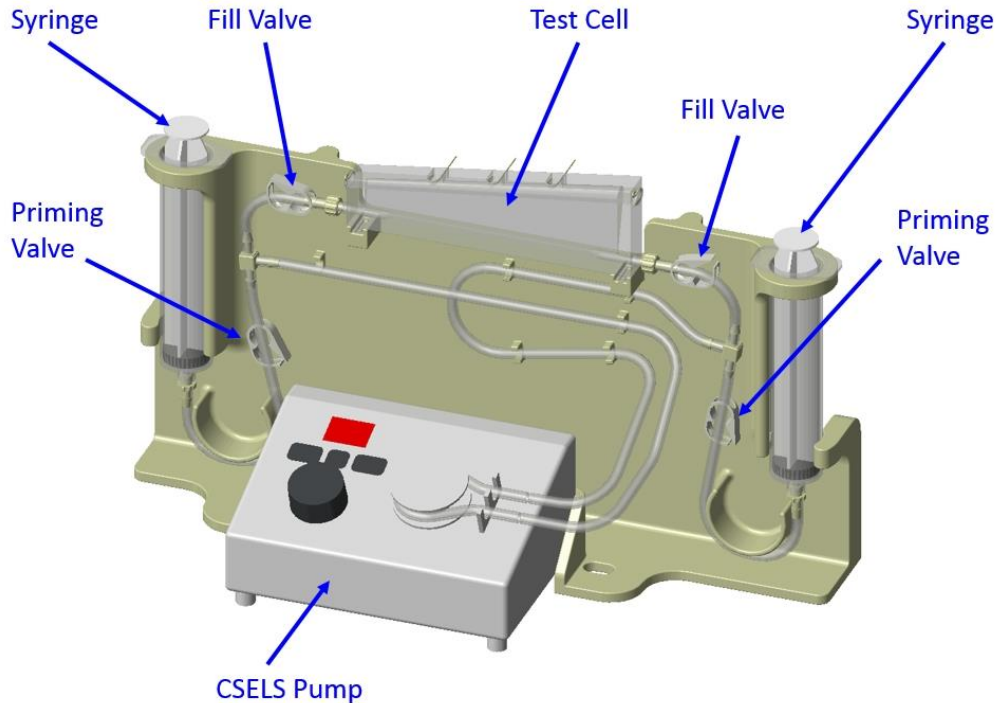

Component	Material
Test Stand	Ultem (3D Printed SLA)
Test Cell and Lid	Accura 60 (3D Printed SLA)
Lid Clips	Stainless Steel
Plant Clips	Stainless Steel
Test Fluid	ISS potable water mixed with Kool Aid® Tropical Punch (from the ISS On-orbit food pantry)
Plant Simulants	Rayon Felt / Nylon String Composite
Pump	Peristaltic, Positive Displacement, from CSELS Experiment
Syringes	COTS Plastic, Luer
Fluid Lines	COTS Tygon
Fittings and Valves	COTS Plastic, Noncontact Pinch Style, Luer

# PWM Plant Simulants

## Simulated taproot plant

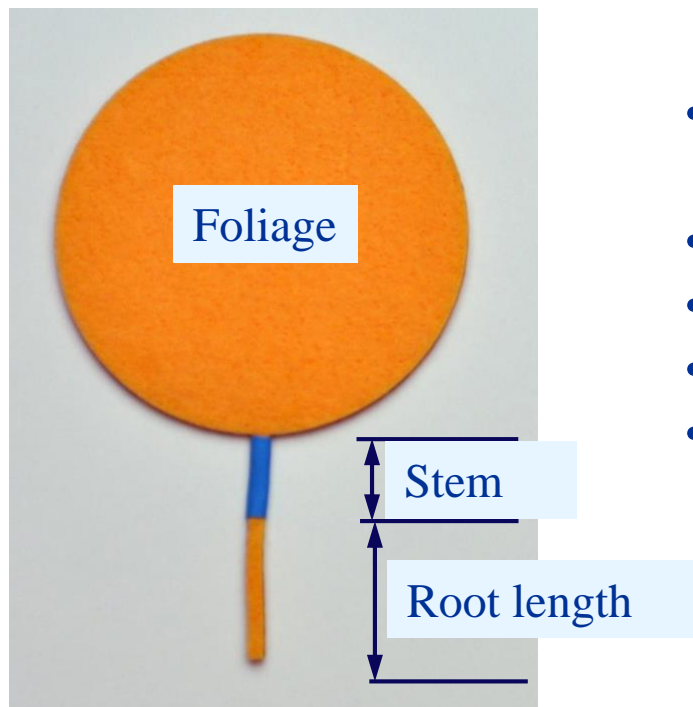

Simulated fibrous root plant

- 4mm thick, uncompressed & washed rayon felt foliage, stem, and taproot
- Uncompressed nylon string as secondary wick for fibrous roots and germination stage
- Max “plant” volume (foliage/stem/roots): 53mL
- Infill wicking rate: 7.7 mL/hr – 155mL/hr
- Evaporation Rate 2 mL/hr – 7.7 mL/hr
- Characteristics based on a typical potato plant from germination to harvest

Simulated “germination” plant with throttled uptake

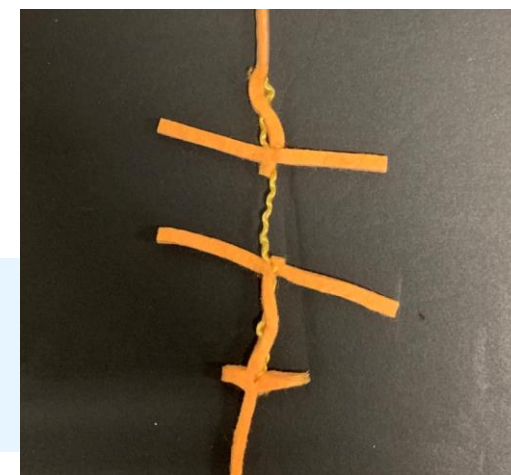



# PWM Operational Overview

1. Collect hardware (including PWM kit, ISS-provided lighting, cameras, potable water, drink mix, and CSELS pump)
2. Assemble hardware on MWA. Start video recording.
3. Slowly prime the system with the test fluid and start the pump (hydroponics only).
4. Take images of the pump rate, shape of fluid in the test cell, and motion of plant roots, porous wicking gradient, saturation gradient, and bubble formation/occlusion at variable flow rates.
5. Drain the system and dispose of the hardware.
6. Downlink videos and still images for analysis.

*Approximately 3 hours of crew time per experiment (3 soil, 1 hydroponics).*

*Soil demonstrations can be left overnight (untended) due to slower wicking rate.*

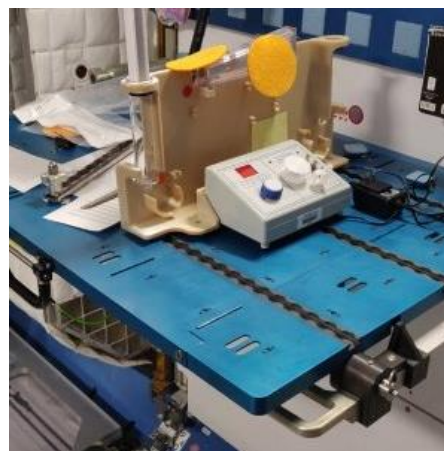
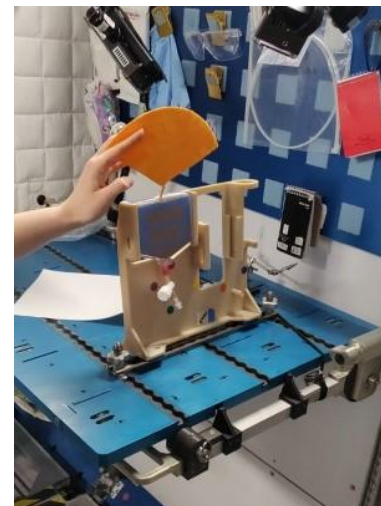

# Importance and Reason for ISS

## Duration of microgravity test conditions:

- System prime and steady-state stability in complex micro-g geometry
- Allows establishment of steady pumped flow with evaporation on timescales that cannot be achieved in drop towers or aircraft.
- Crew tended experiment
  - Extra science potential for g-jitter stability response, bubble formation/occlusion/recovery

CSELS Experiment example of long-duration evaporation rate testing

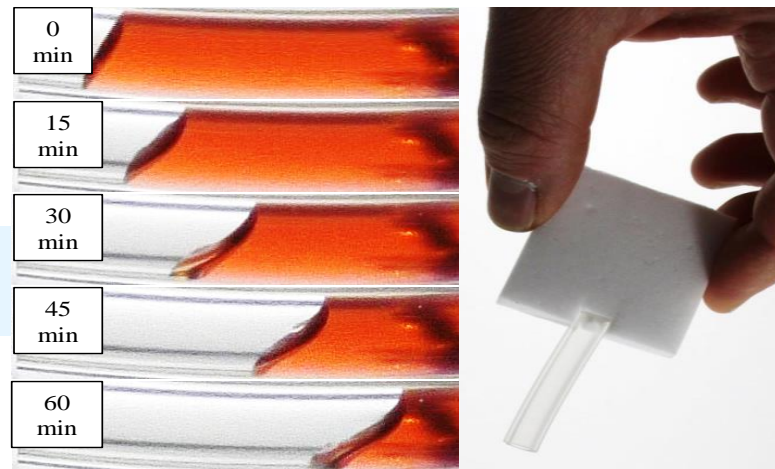



# Key Questions and Impact on Advancing the Field

- Where are the **operational limits** for 1g vs low-g stability regimes for poorly wetting liquids such as contaminated/sugary water?

Hydroponics system regime map with a single taproot in 1g lab testing

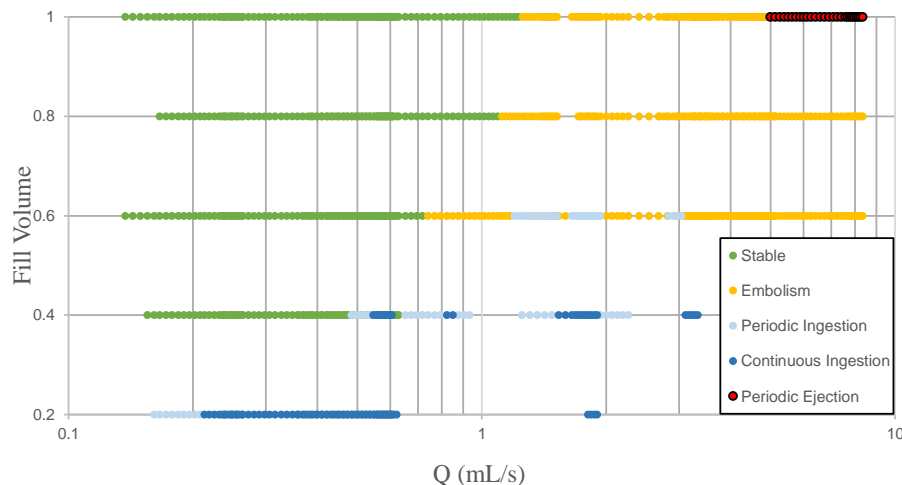

**Need:** Providing plants with ready access to both air and water remains a significant issue. The lack of convective mixing has implications for the movement of water, oxygen and solutes through the root zone. Most plants returned from microgravity have experienced some degree of hypoxia stress or root zone solute stress.

**Application:** Long-term food production systems for missions to the Moon and Mars, as well as the immediate need for ISS food supplements to the crew diet. PWM will demonstrate the low-gravity role of surface tension, wetting, and system geometry to effectively replace the role of gravity in certain terrestrial plant growth systems.

# Issues

- **Fast-to-flight**
  - During development, seemingly small issues can have a major impact on schedule
  - 3D printed model crack during assembly
  - However, quick turnaround from ATP to FHA (13 months) provides huge science payoff (increased TRL in relevant environment)
  - Lessons learned and downlinked data will inform PWM 3 & 4 designs, scheduled to launch to ISS on similarly quick schedule



# Requirement Rationale

- PWM is conceptually similar to Capillary Flow Experiments (CFE) and CSELS (Capillary Structures for Exploration Life Support), both led by the same PI
- PWM is a further demonstration of capillary methods for applied fluid control, potential path forward is known
- Reutilizing similar or identical hardware, flight-cert. COTS, task listable, same players from original experiments
- Both of these experiments yielded dozens of hours of extra crew time for extended science due to their simple nature

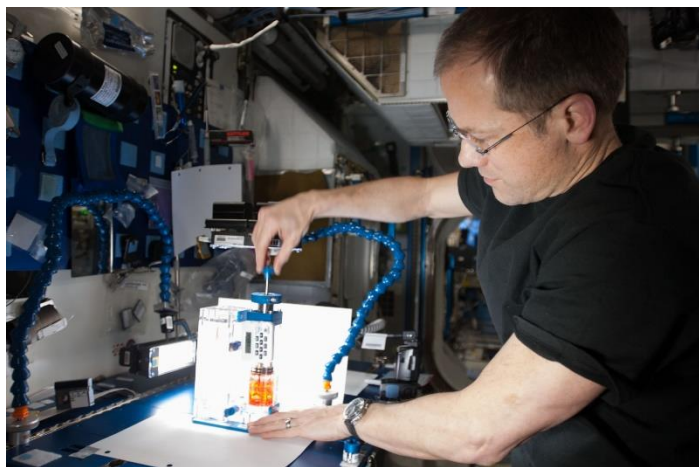





# Benefits/Spin-off Applications

- Space:
  - Increased confidence for capillarity as a method of containment (PWM is in open cabin air with removable lid)
  - Increased knowledge of flow regime maps for poorly wetting liquids, and ISS environment's influence on evaporation rates
  - Potential to influence next generation of space food production systems for ISS, Moon, and Mars
- Earth Benefit
  - Scale models can easily be manufactured to demonstrate low-g fluid behavior in 1g environment
  - Optimization of water uptake, thermal balance, etc. has direct application to terrestrial plant growth systems



# Backup Charts

# PWM Flow Loops

PWM Soil

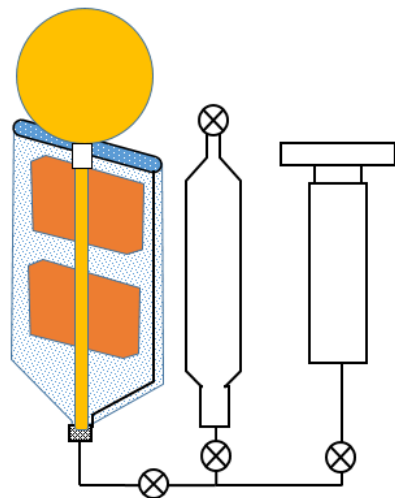

PWM Hydroponics

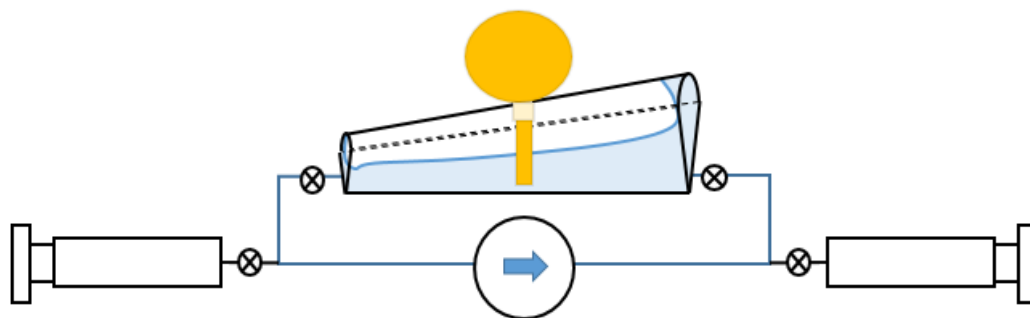

# Hydroponics Test Section

- Governing Equations based on ISS Capillary Corner Flow Experiment (~2013)
- Use Concus-Finn critical contact angle to control liquid position

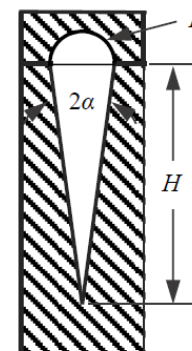
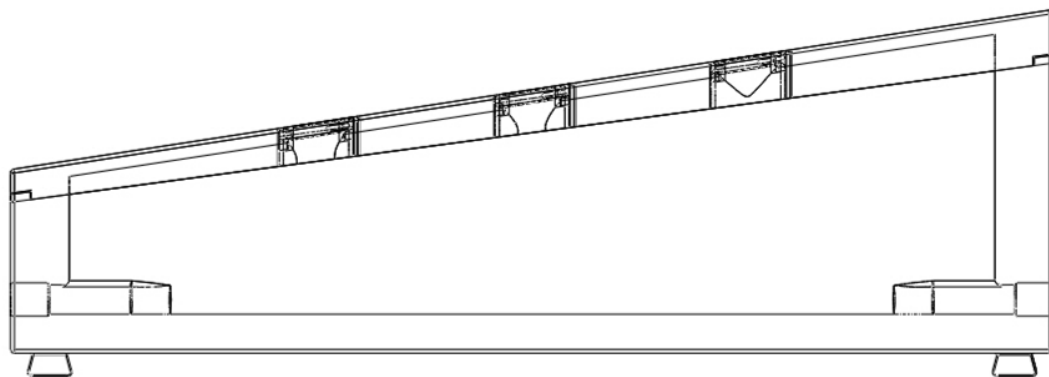
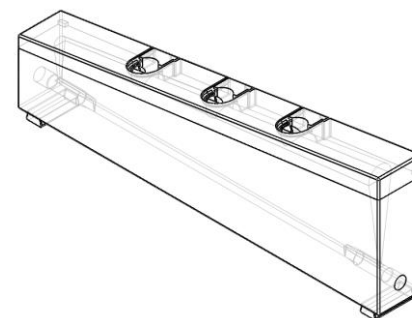

# Hydroponics Test Section

- Liquid Interface Position

$$h = H_i \left( 1 - \left( 1 - \left( \frac{H_o}{H_i} \right)^3 \right) \frac{z}{L} \right)^{1/3}$$

- Flow Rate

$$Q = \frac{\sigma F_A H_i^3}{\mu} \frac{F_i (\sin \alpha)^2}{3L f} \left( 1 - \left( \frac{H_o}{H_i} \right)^3 \right)$$

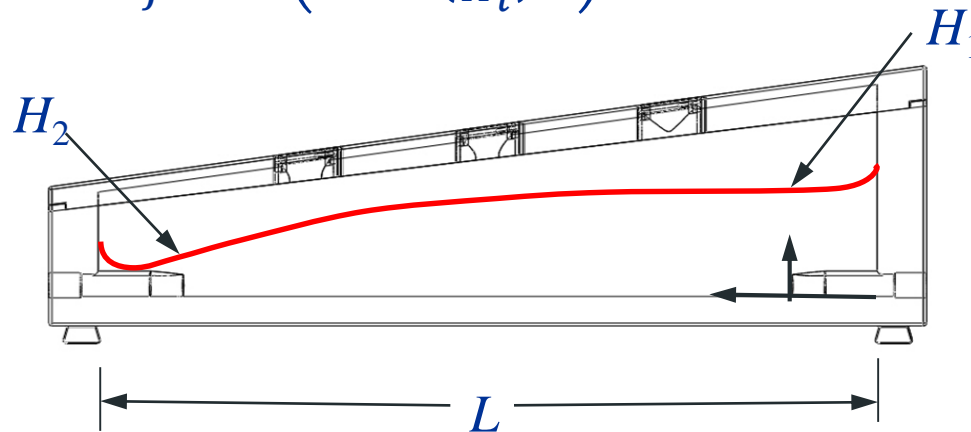



# PWM Test Matrices

- Soil (3 modules)

Plant	Test Loc Setup	Test Setup incl gather + video	Fill + still (Crew Time)	Beginning of Foliage Sat (hr) (no extra Crew Time)	Top Up Task List? (Crew Time)	Refill (Crew Time)	Battery Change (Crew Time)	Teardown + Stow (Crew Time)	Approx Fluid Volume Total 48 hr (mL)
Fast	0.5	1.5 hr	1	1.5	0.5	0.5	0.25	1 hr	325/350
Medium	0.5	1.5 hr	1	3	n/a	n/a	0.25	1 hr	126 mL
Slow	0.5	1.5 hr	1	7	n/a	n/a	0.25	1 hr	126 mL

- Hydroponics (1 module with several plant types over 2 days)

Plant Type	Number of Plants	Plant Position	Time (hr)	Note	Approx Max Fluid Volume Total per day (cut foliage) (mL)	Approx Max Fluid Volume Total per day (uncut foliage) (mL)
n/a	0	n/a	1	stable	120	250
PWM-H-C	1	2	1	Stable	120	250
PWM-H-C	2	1, 2	1	stable	120	250
PWM-H-C	2	1, 2	0.5	Ingestion	120	250
PWM-H-F	1	2	1	Stable	120	250
PWM-H-F	2	1, 2	1	Stable	120	250
PWM-H-F	3	1, 2, 3	1	Stable	120	250
PWM-H-F	3	1, 2, 3	0.5	ingestion	120	250



# Fluid/Soil Properties

- PWM Soil & Hydroponics Test Fluid
  - Water mixed with “Tropical Punch” red drink mix from ISS pantry
  - Sucralose sweetener included in drink mix
  - Kinematic viscosity: 1 CS
  - Benefits:
    - Flow visualization
    - Poorly wetting fluid (water)
    - Mixed sweetened solution similar to nutrient mix
    - Tox 0 – Approved by JSC toxicology and MSFC ECLSS groups
  
- PWM Soil Media
  - Arcillite
    - Commonly used as soil basis for prior NASA plant growth systems such as VEGGIE, PONDS, APH, etc.
    - Calcinated clay particles, highly wetting when dry, clumps when saturated
  - Magic Sand
    - Nonwetting hydrophobic media
    - Breathable soil in contrast to the arcillite



# PWM Microgravity Requirements

- Design is stable for disturbances up to  $10^{-2}$  g, most common perturbations are  $10^{-4}$  g
- Stability: water will remain in *open container* test cell due to surface tension forces
- Numerical interface stability work is still underway
- Upscaling design is dependent on the g environment
- ISS cabin relative humidity and air temperature will be obtained post-experiment