



Background credit: NASA, STScI

# Infrared telescopes: an invaluable resource to unravel the mysteries of the universe

**Giuseppe Cataldo**

**NASA Goddard Space Flight Center**

ISAE-SUPAERO, Toulouse, France

25 September 2019

**NASA unclassified. Approved for public release.**

# How it all started



2004-2008

BS  
Aerospace  
Engineering  
(Milan)

2 MS  
Aeronautical &  
Aerospace  
Engineering  
(Milan + Turin)

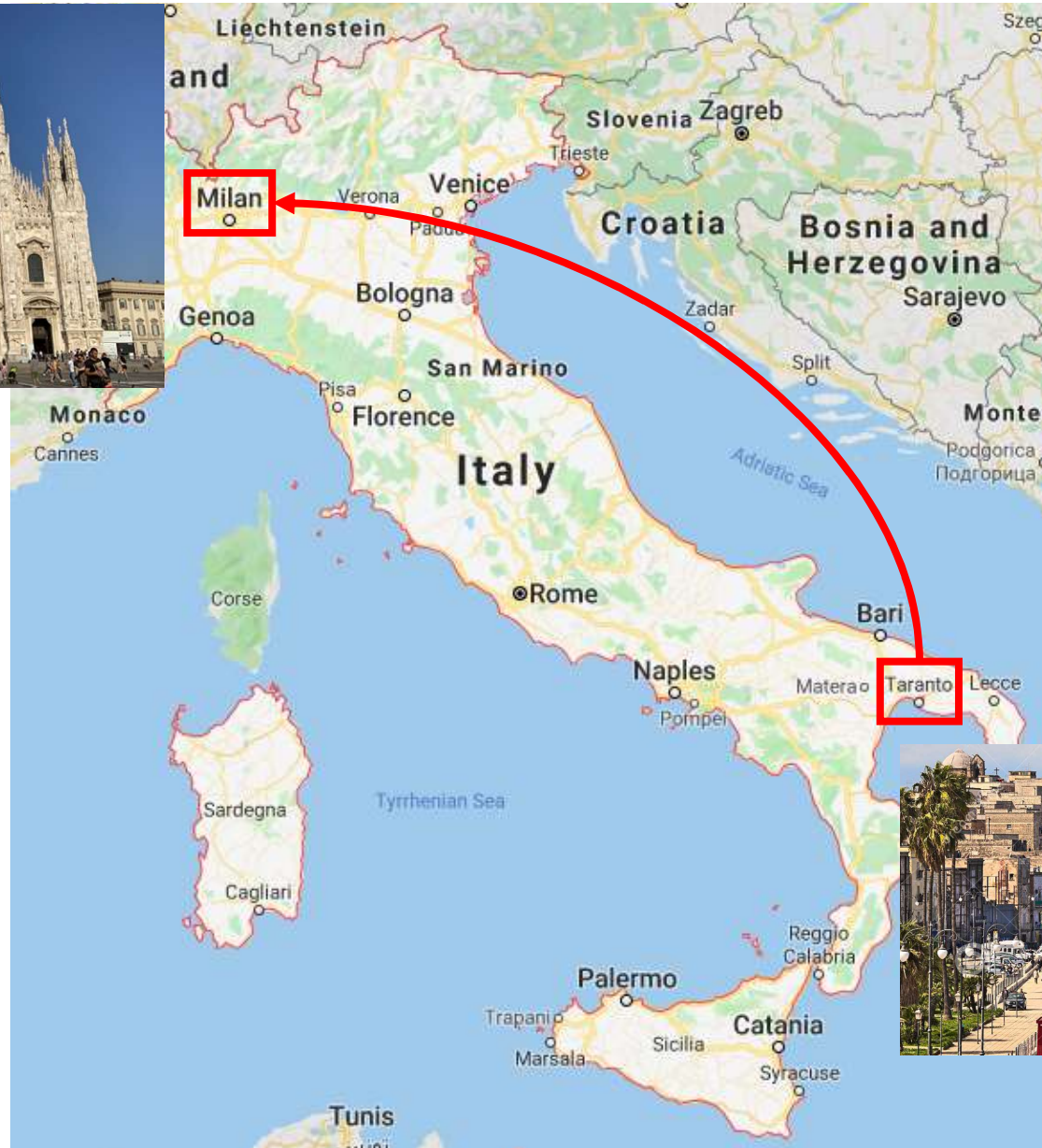

# Wandering around Europe



2008-2010

Diplôme d'Ingénieur  
within the  
TIME (Top Industrial  
Managers for Europe)  
double-degree  
program

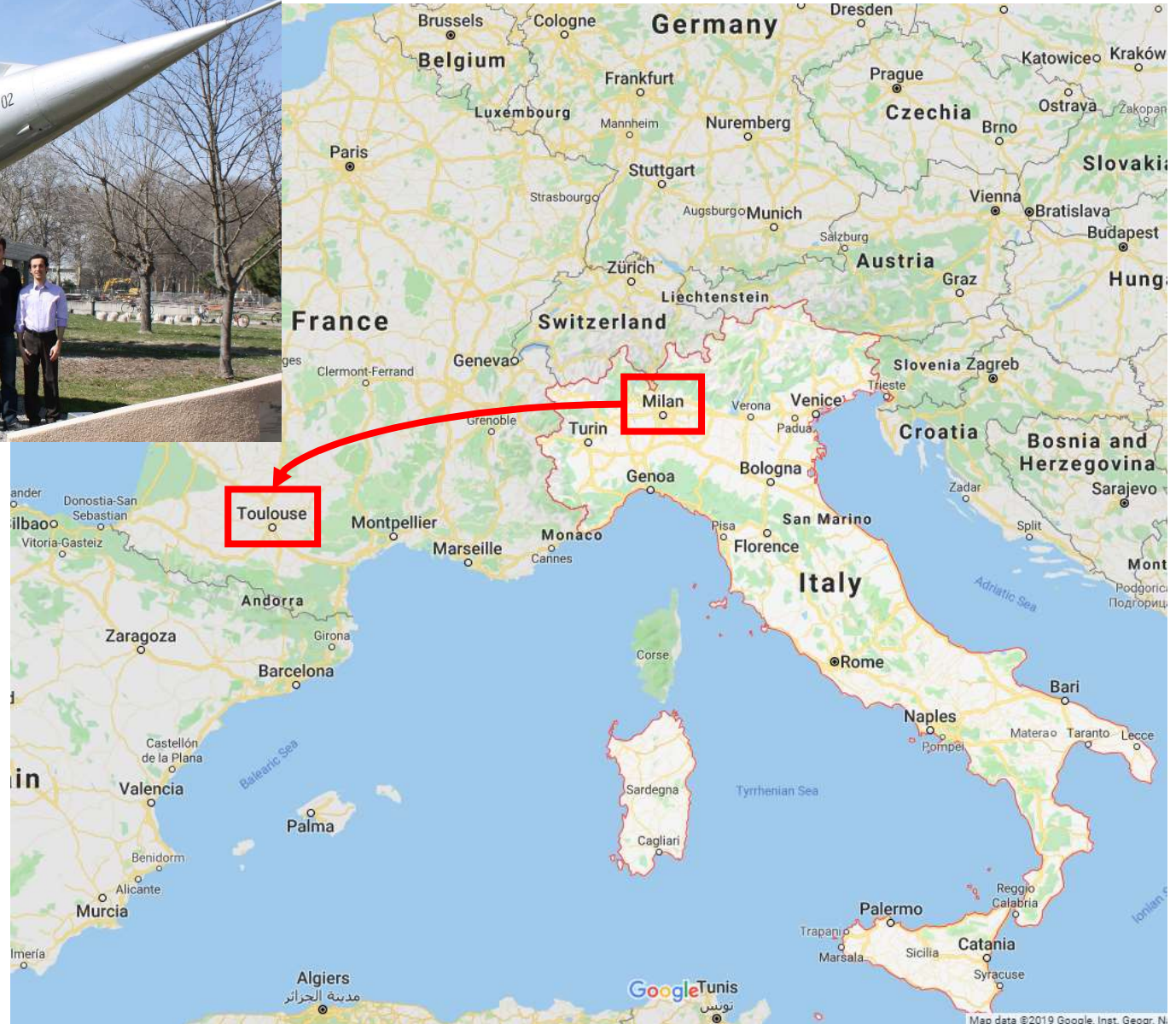

# Across the Atlantic

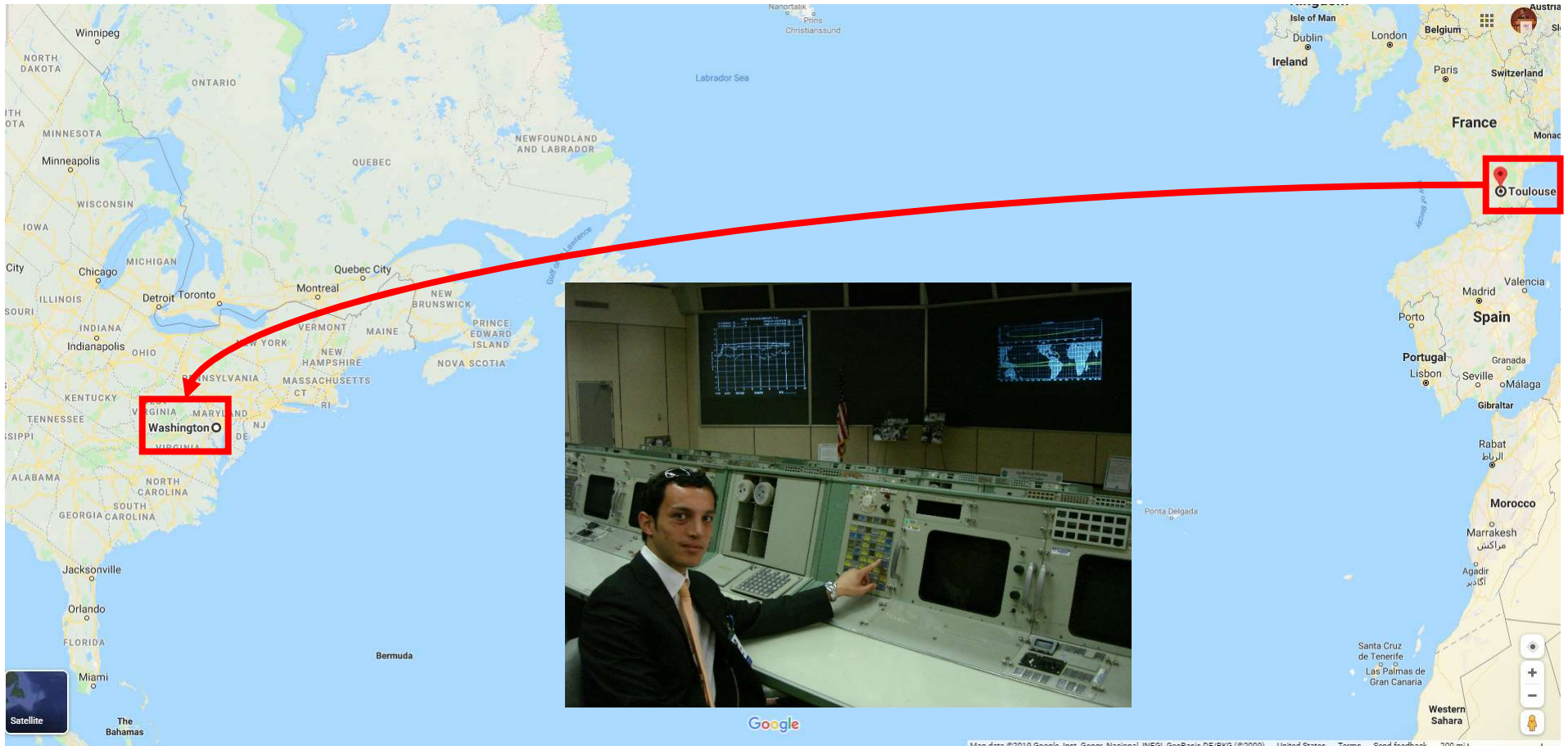

**NASA Academy 2009**  
(NASA Goddard Space Flight Center)

Sponsored by ESA with another European student +  
1 other SUPAERO sponsored by CNES + 17 US students

PIR (Summer 2009)  
PFE (2010)  
Graduation (2010)  
Aerospace Engineer (2010-2012)

# I thought I was done with school...



2012-2015

PhD  
MIT AeroAstro

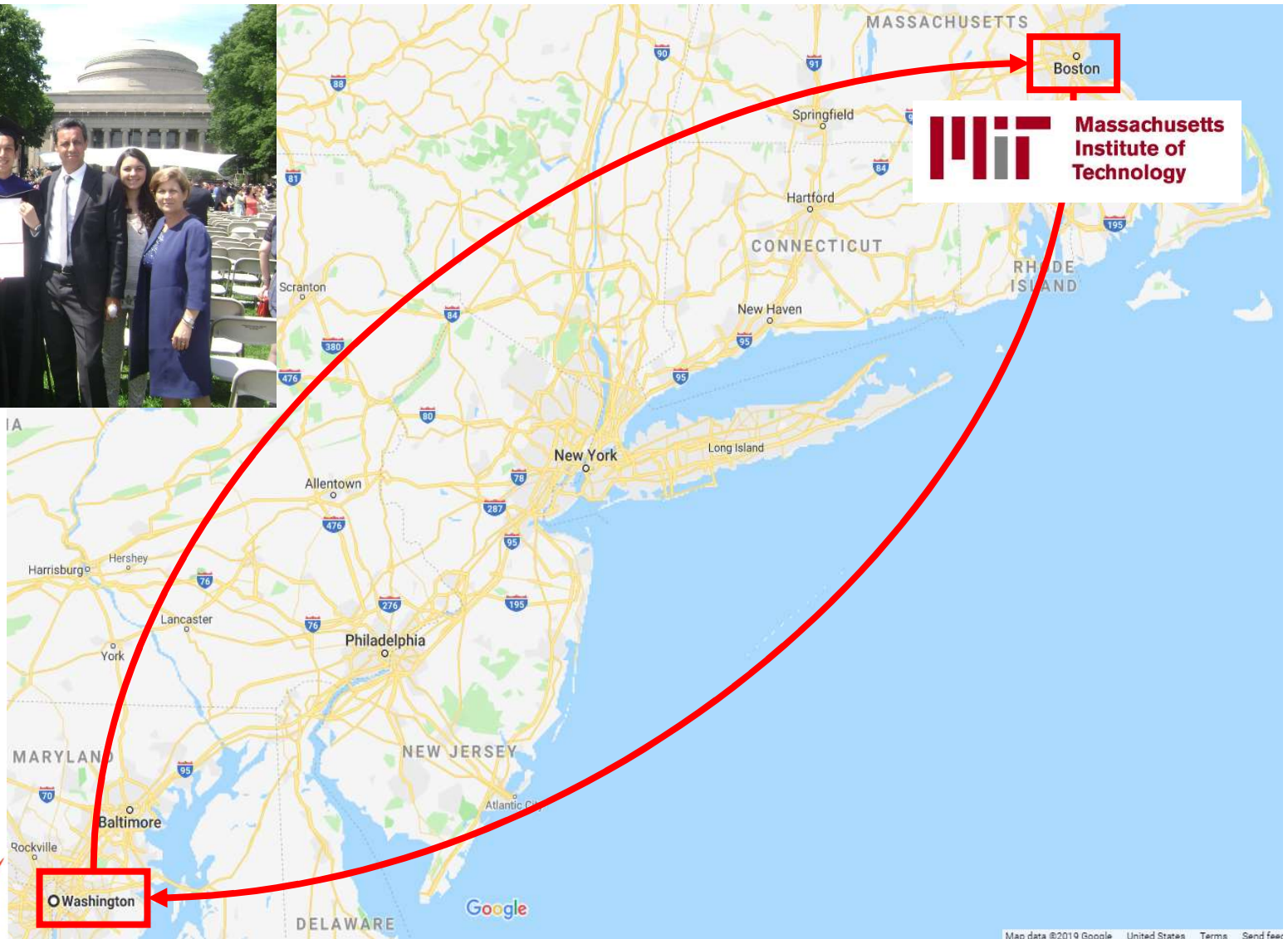

# What about now?

- Development of infrared technology
- Systems modeling
- Multidisciplinary design optimization
- Uncertainty quantification
- Project and mission management

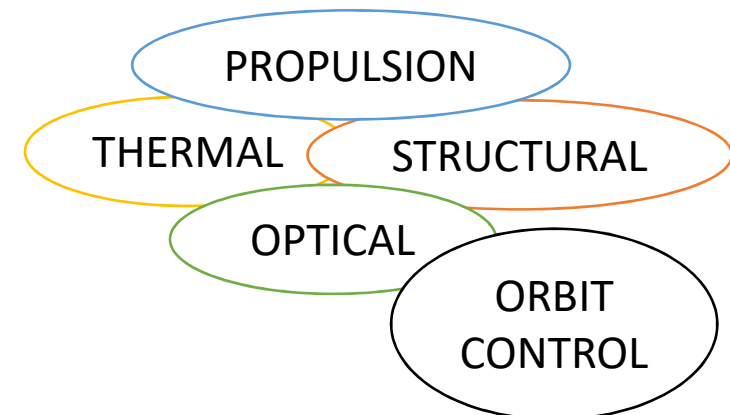
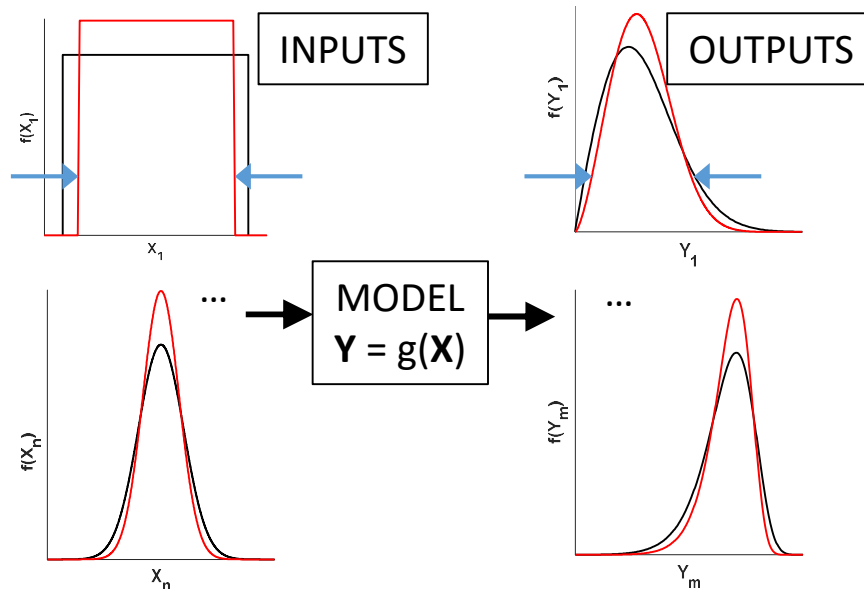
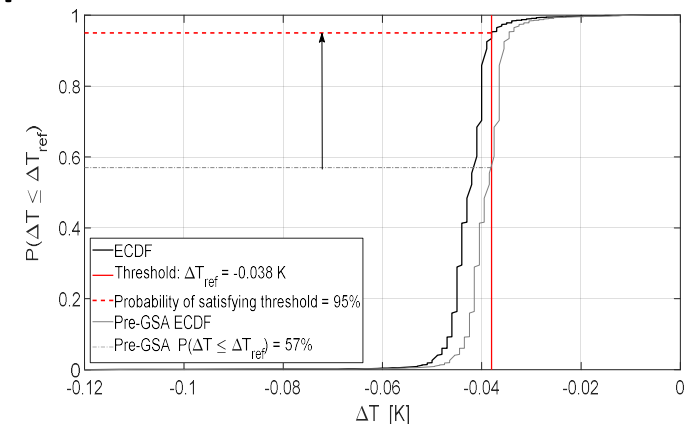
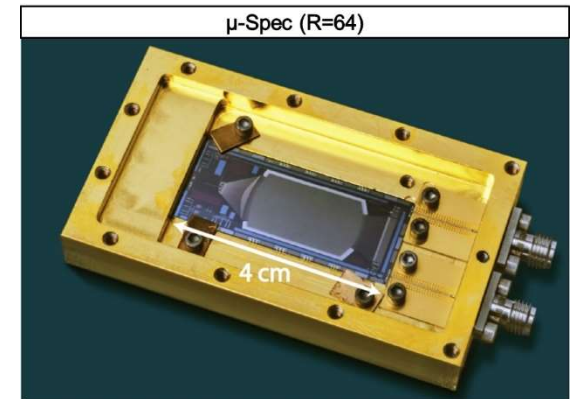

# Where can the energy be found in the Universe?

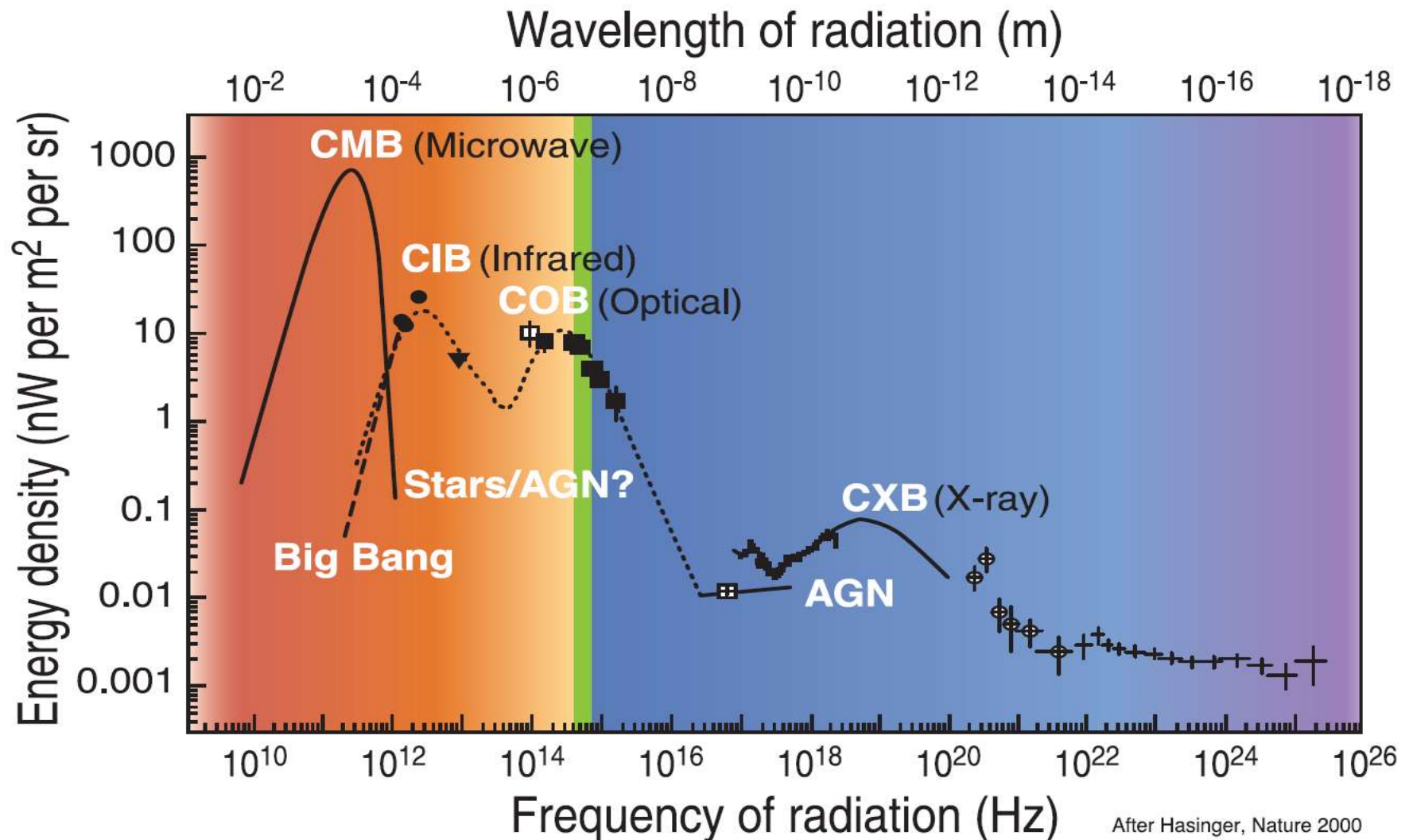

Because of the universe expansion, much of the visible and ultraviolet light released billions of years ago has been stretched into the **far-infrared** and **microwave** region of the electromagnetic spectrum.

# The history of the universe through the infrared

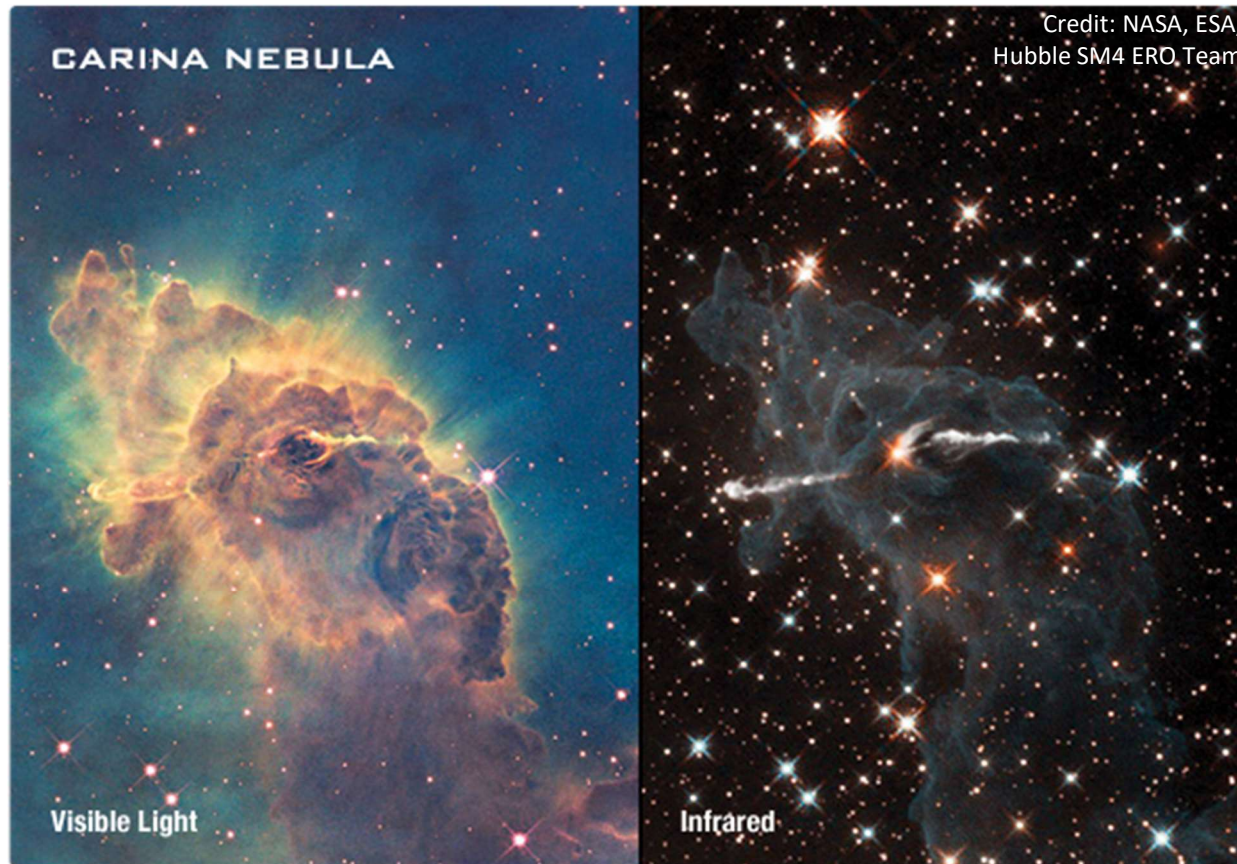

- Half of the remnant electromagnetic light from stars and galaxies is in the far-IR.
- Most of the energy from star formation and accretion activity emerges in the far-IR.
- The mechanisms driving these processes are inaccessible in the optical/NIR.

Stars forming in the Carina nebula can be seen in the infrared behind the pillar of gas and dust that appears in the visible-light image.



# The limiting effects of Earth's atmosphere

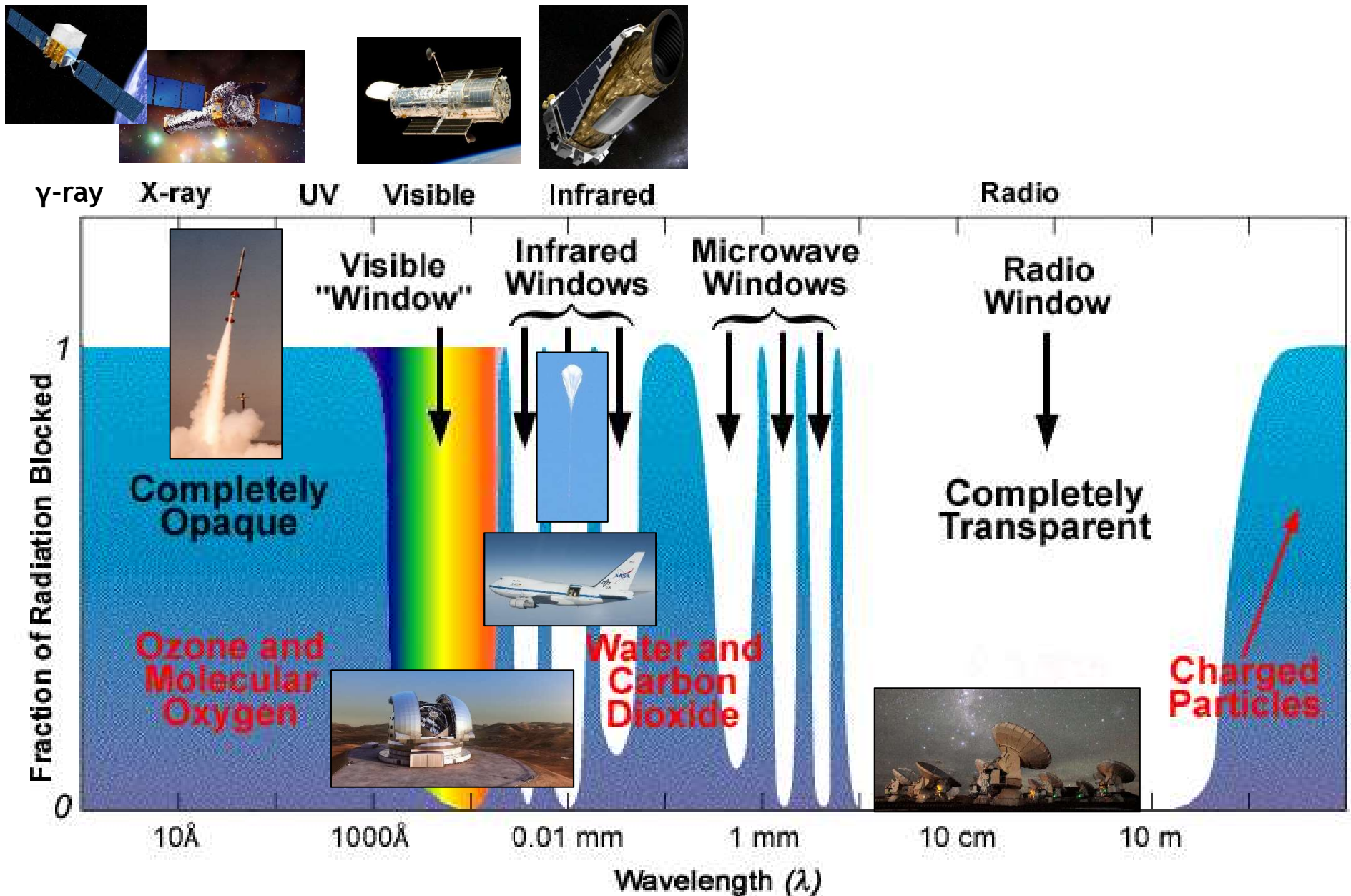

# IR space-borne telescopes and balloons are the new frontier

**SOFIA** (current)



**JWST** (2021)



**EXCLAIM** (2022)

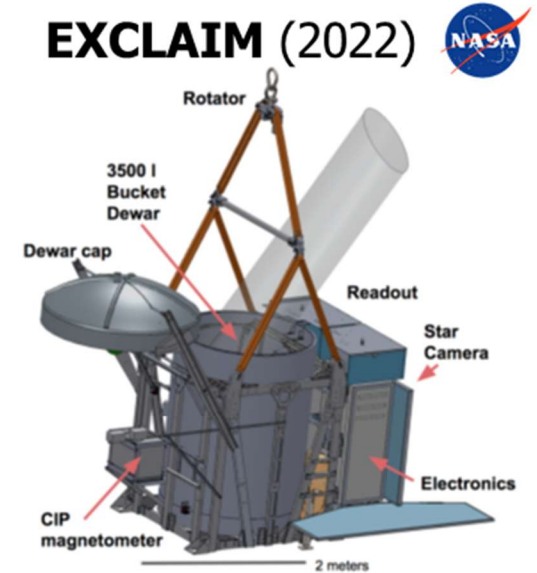

**WFIRST** (~2025)



**SPICA** (~2032)

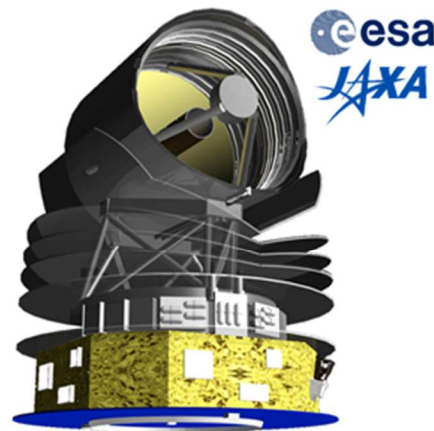

**OST?** (~2035)

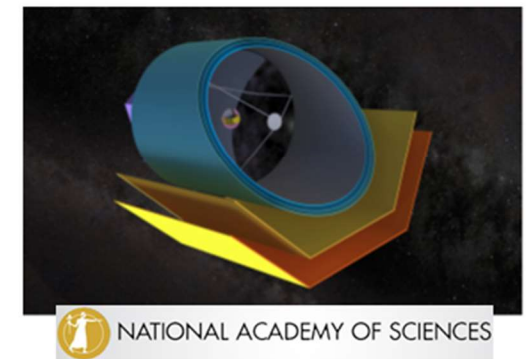

# The Prime-focus Infrared Microlensing Experiment (PRIME)

Diameter: 1.8 m

FOV: 1.56 deg<sup>2</sup> (6 full Moons)



Collaboration between:

- Osaka University (PI)
- NASA Goddard
- JAXA
- University of Maryland
- SAAO
- + others

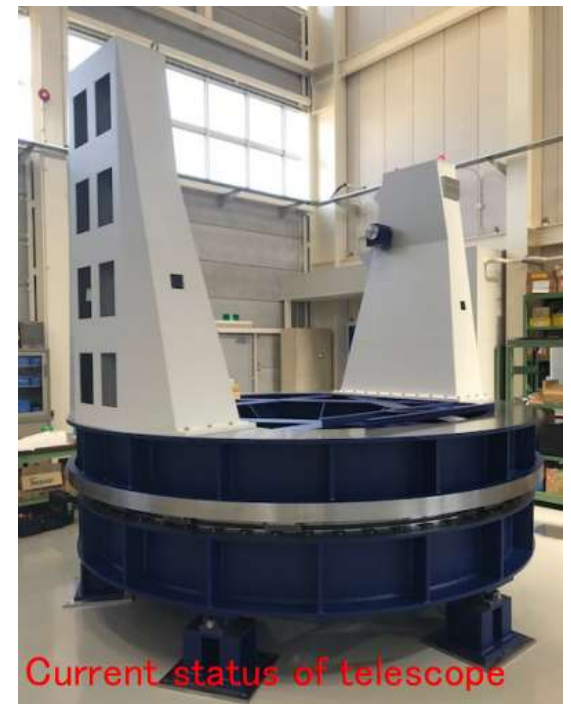

# The Prime-focus Infrared Microlensing Experiment (PRIME)

Near-infrared camera with four H4RG-10 detectors and cryocoolers

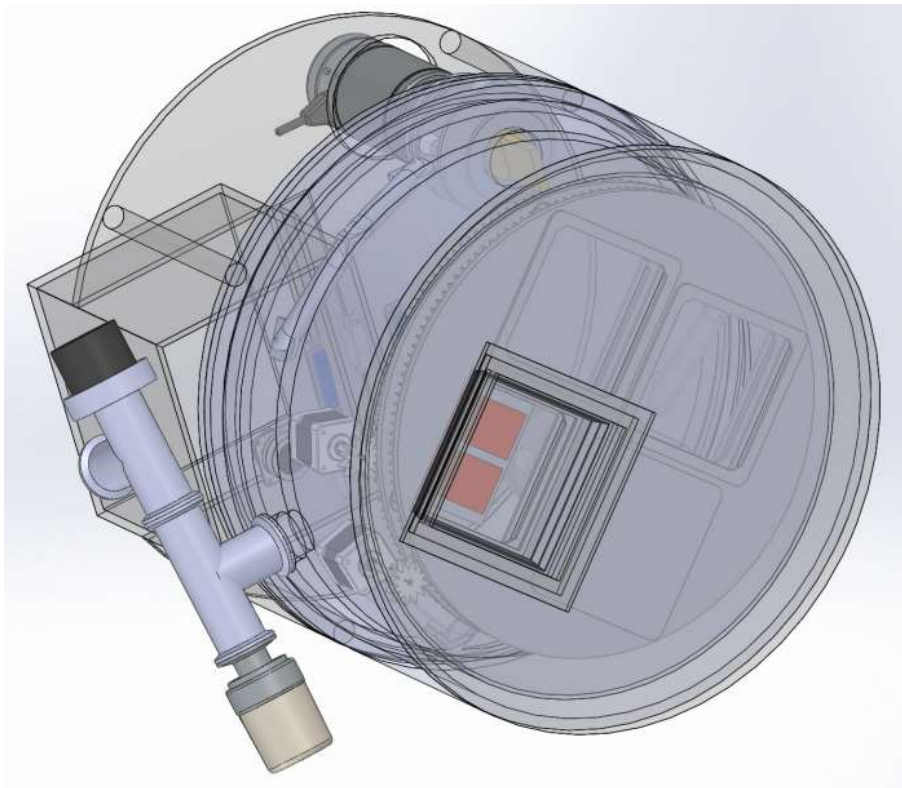

Science objectives:

1. Microlensing Exoplanets
  - Study low-mass planets outside of snowline
  - WFIRST microlensing survey field optimization
  - Concurrent observations with WFIRST
2. Other sciences
  - IR astrophysics
  - Transients: GW, GRB, SNe, etc.

# The EXperiment for Cryogenic Large-Aperture Intensity Mapping (EXCLAIM)

- Infrared balloon-borne telescope ( $\sim 550\text{-}710\ \mu\text{m}$ )
- $\sim 1\text{-m}$  primary mirror
- Will map the emission of redshifted CO and singly-ionized carbon lines over a redshift range  $0 < z < 3.5$ 
  - **Intensity mapping**: measure the statistics of brightness fluctuations, instead of detecting individual galaxies, in cross-correlation with a rich spectroscopic galaxy catalog, such as BOSS
- 6 Micro-Spec spectrometers

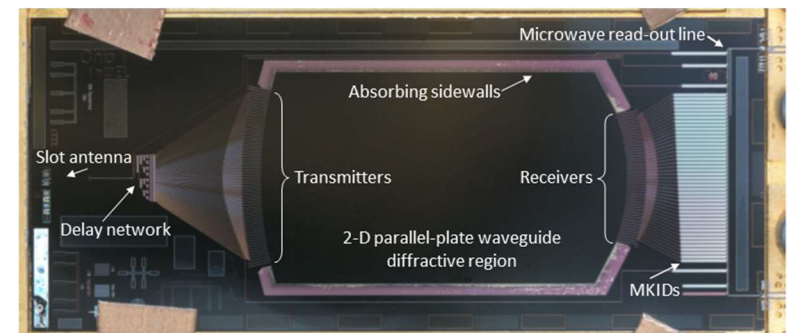
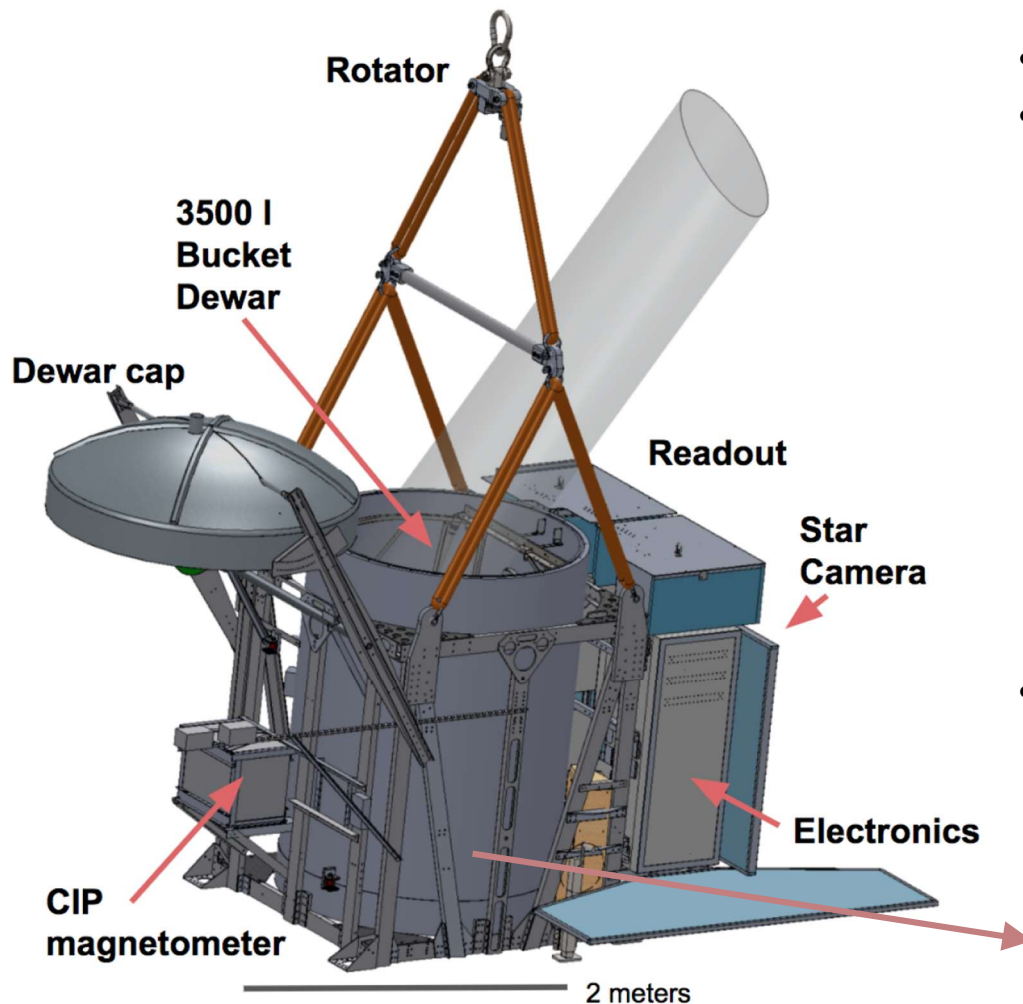

# Ballooning!

NASA PIPER mission  
at Ft. Sumner, NM  
(2017 field work)

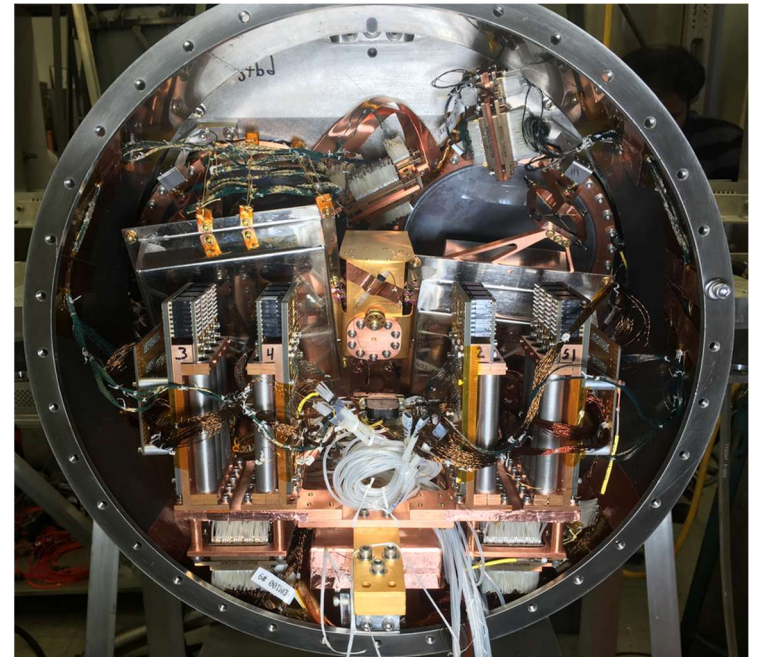

# JWST: the future of astrophysics

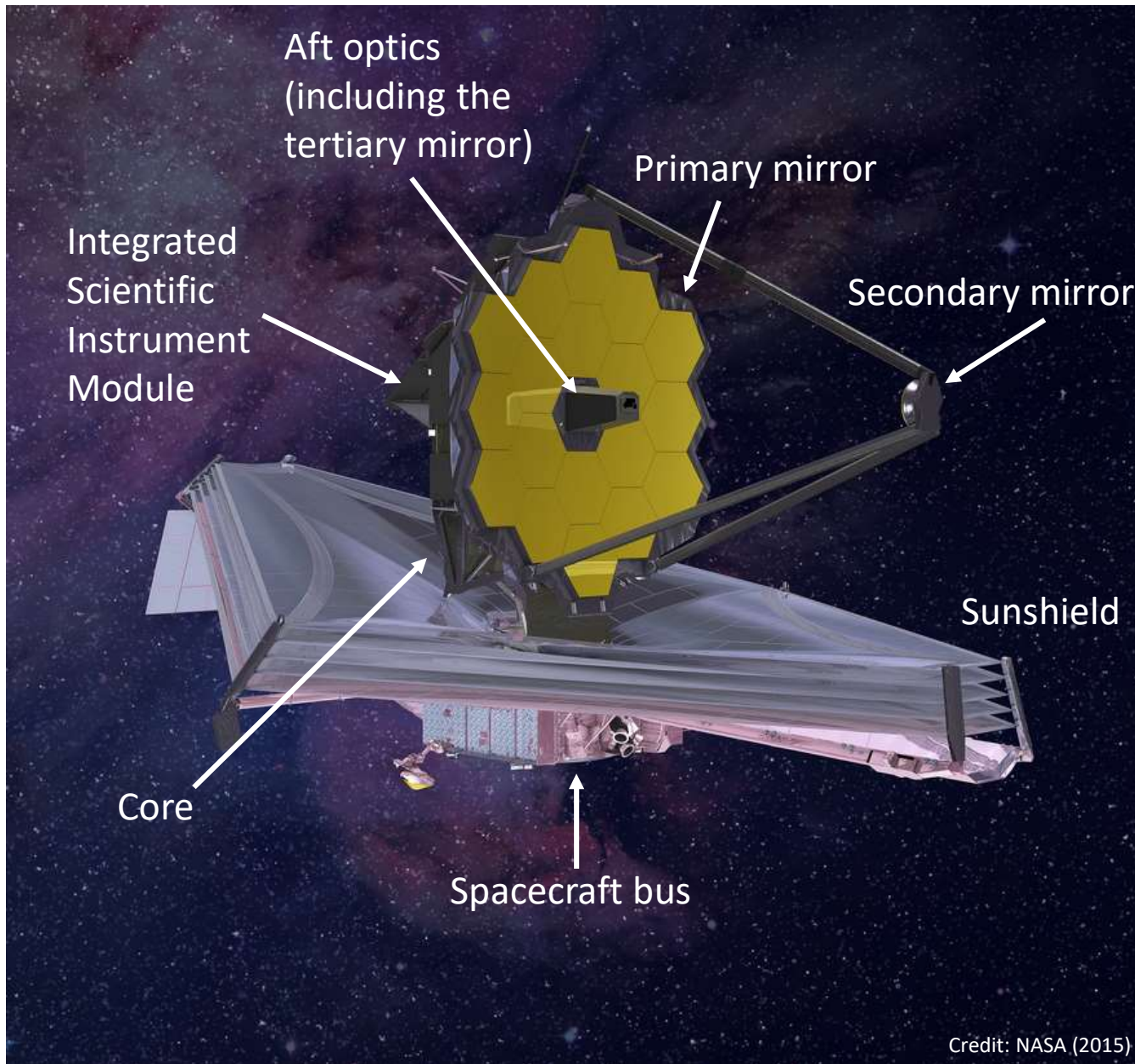

- Infrared telescope
- Successor to the Hubble Space Telescope
- To be launched no earlier than March 2021
- International effort of NASA, ESA and CSA
- Current status: Phase D – Integration and Testing

# Who was James Webb?



Credit: NASA

- Second NASA Administrator
  - From 1961 to 1968
  - Succeeded Keith Glennan
- Oversaw the Mercury, Gemini and Apollo programs
- He inspired NASA's successful science programs
- Not a scientist or engineer!
- 75 space science missions to study the as-yet unknown environment of space



# Who's bigger and stronger?

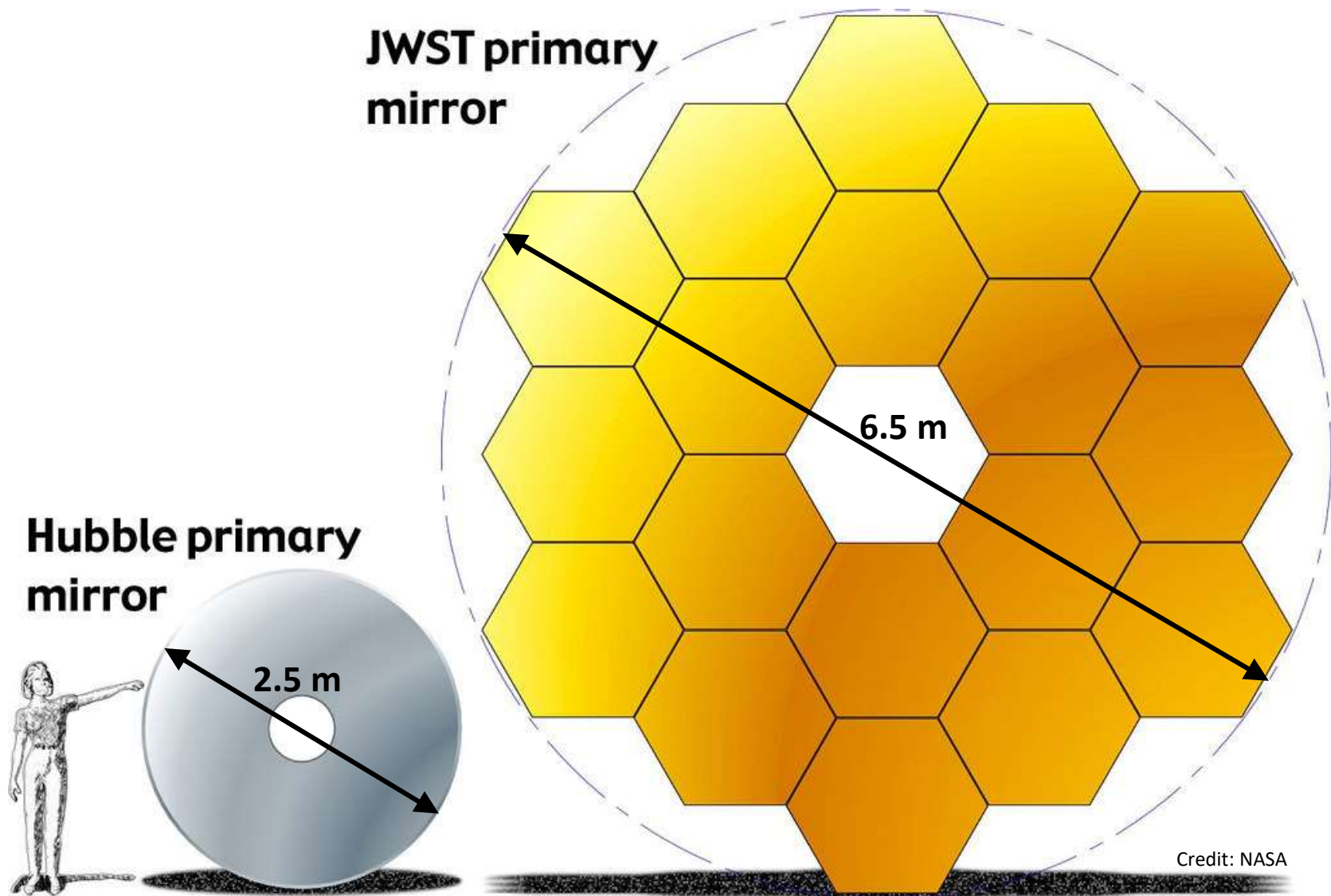

# The mirrors – or the eye

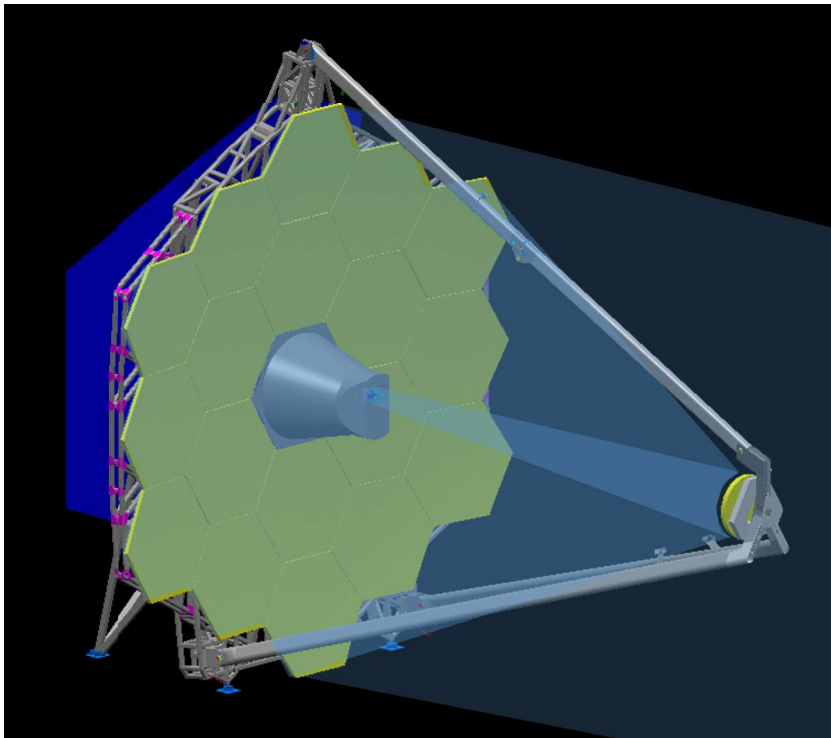

- 18 primary mirror segments
- 6 degrees of freedom + radius of curvature correction
- Made out of **beryllium**
  - 6X stiffer than steel
  - 3X lighter than aluminum
    - 20 kg final weight (each)
  - Thermal stability
- Gold coated
- 40-K operation
- Cryo-polishing required

**FUN FACT:** If JWST were on the surface of the Earth looking at the Moon and a candle were lit on the shaded side of the Moon, JWST would detect it.

**JWST will see 1,000 times better than the human eye!**

[Mirror alignment](#)

# The primary mirror

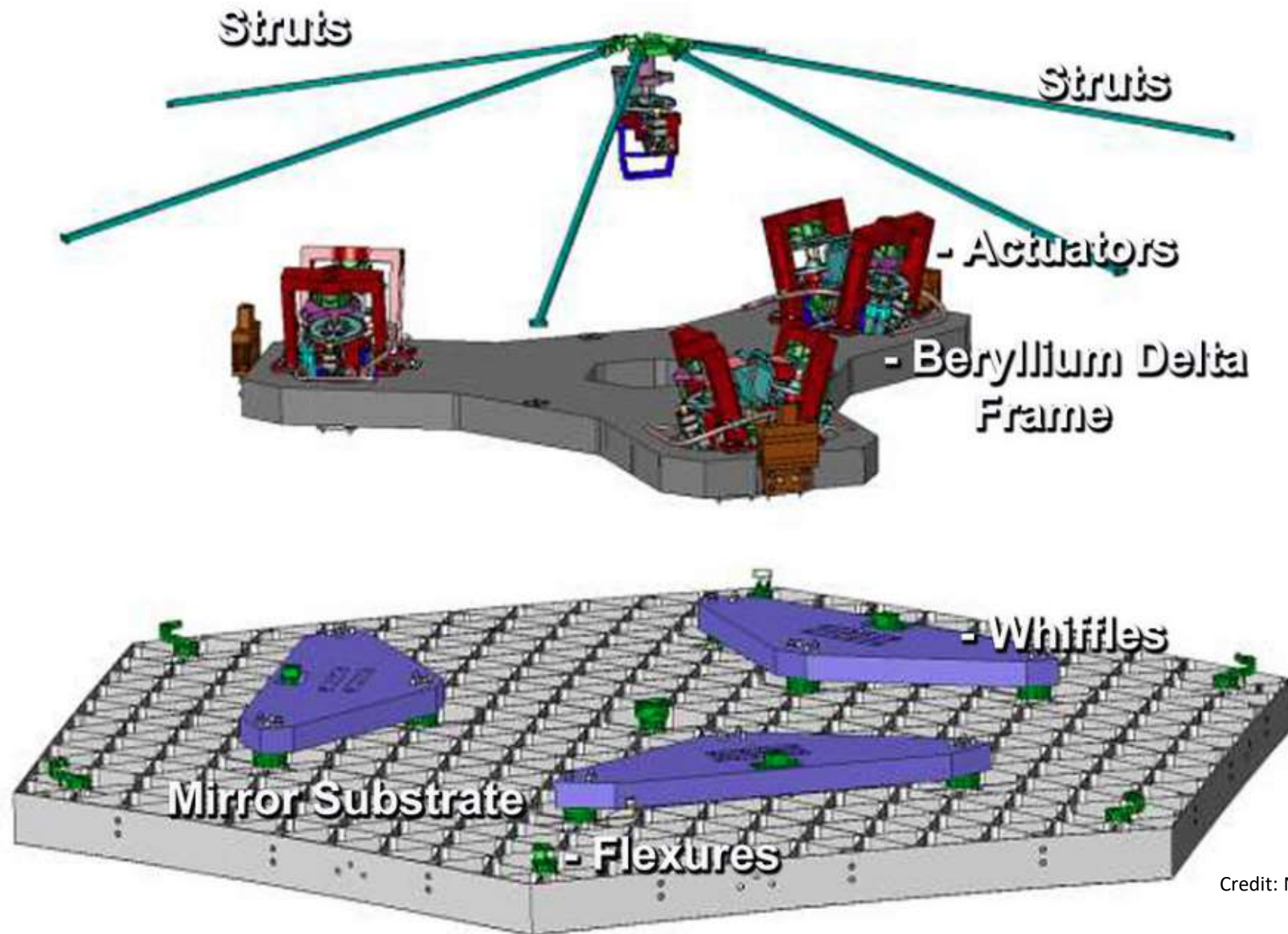

Credit: NASA

# The instruments – or the brain

FGS/  
NIRISS

NIRCam

MIRI

NIRSpec

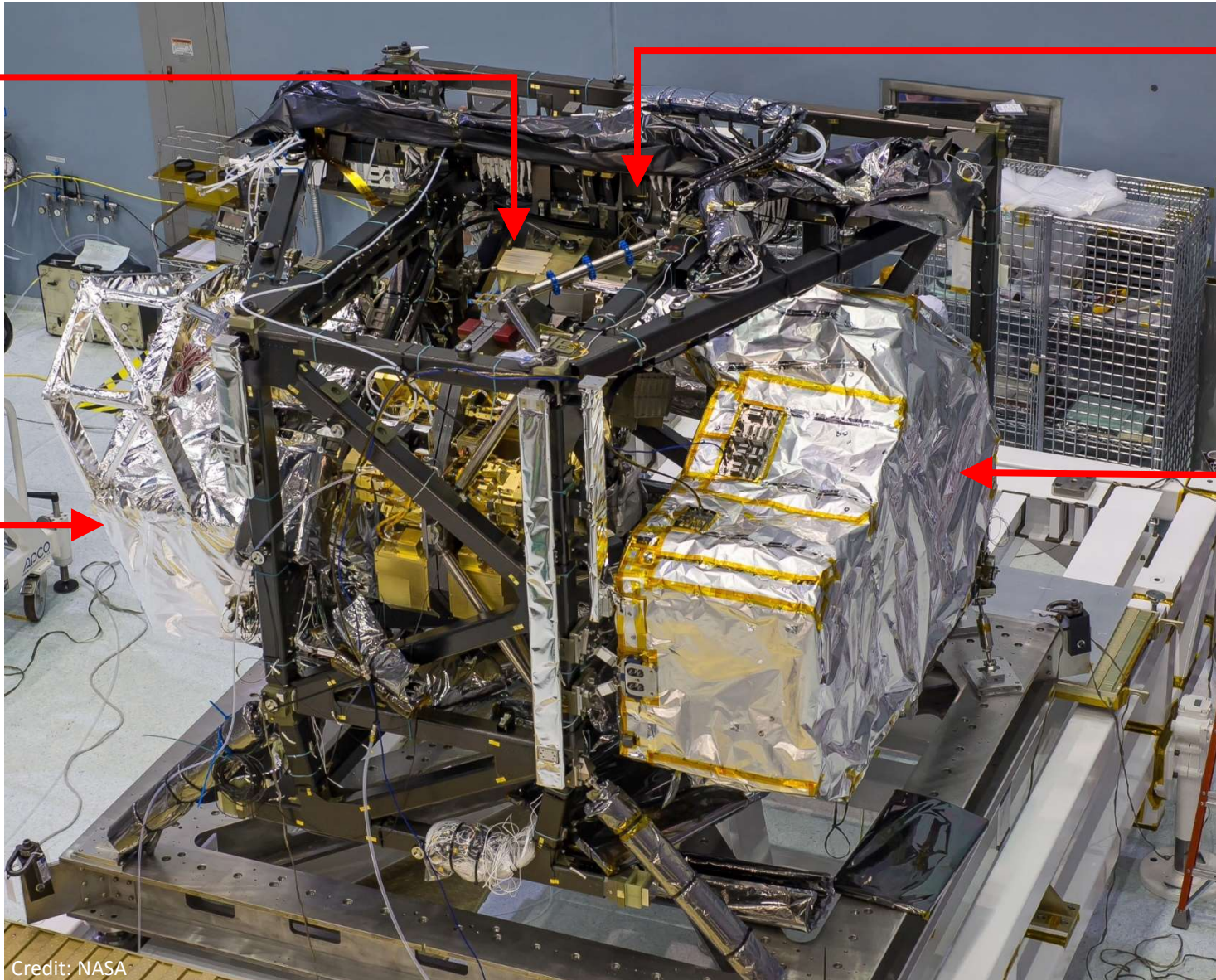

Credit: NASA

# The microshutters: multiple eyes open

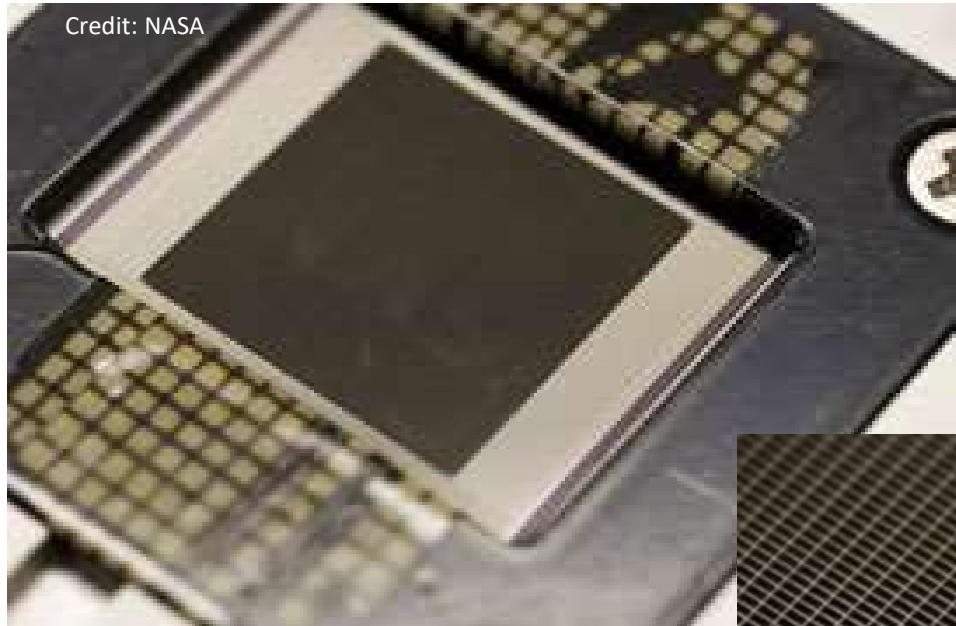

The entire microshutter device consists of more than 62,000 individual windows with shutters arrayed in a waffle-like grid

One of four array quadrants of the microshutter device (shown above) is about the size of a postage stamp

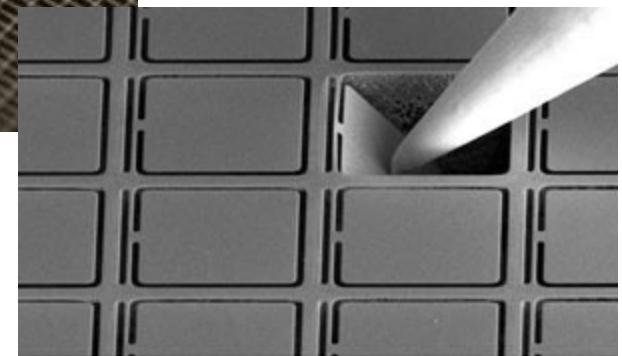
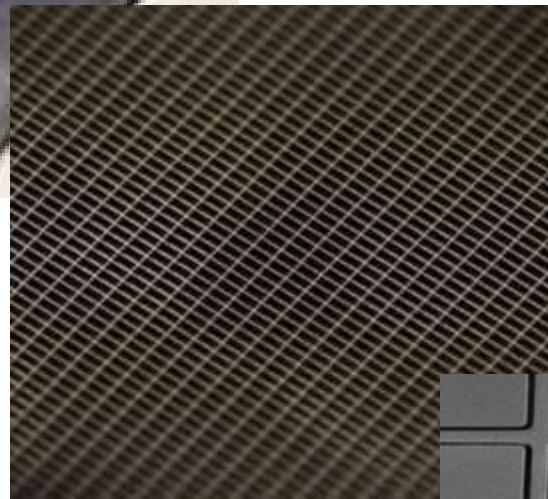

**Multi-object spectroscopy with up to 100 targets**

# Where is JWST going to live?

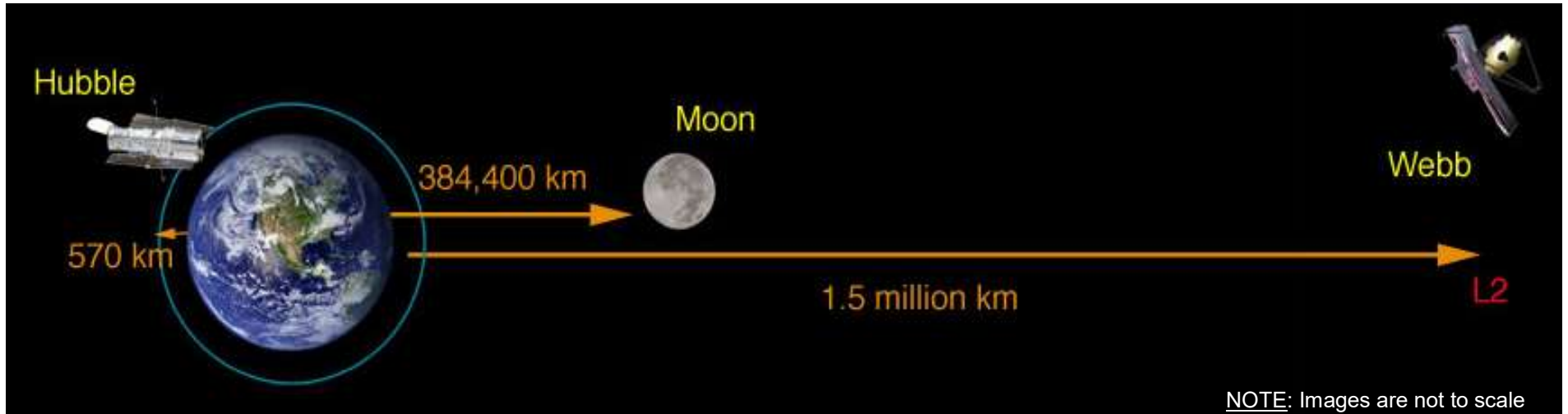

# What is special about its orbit?

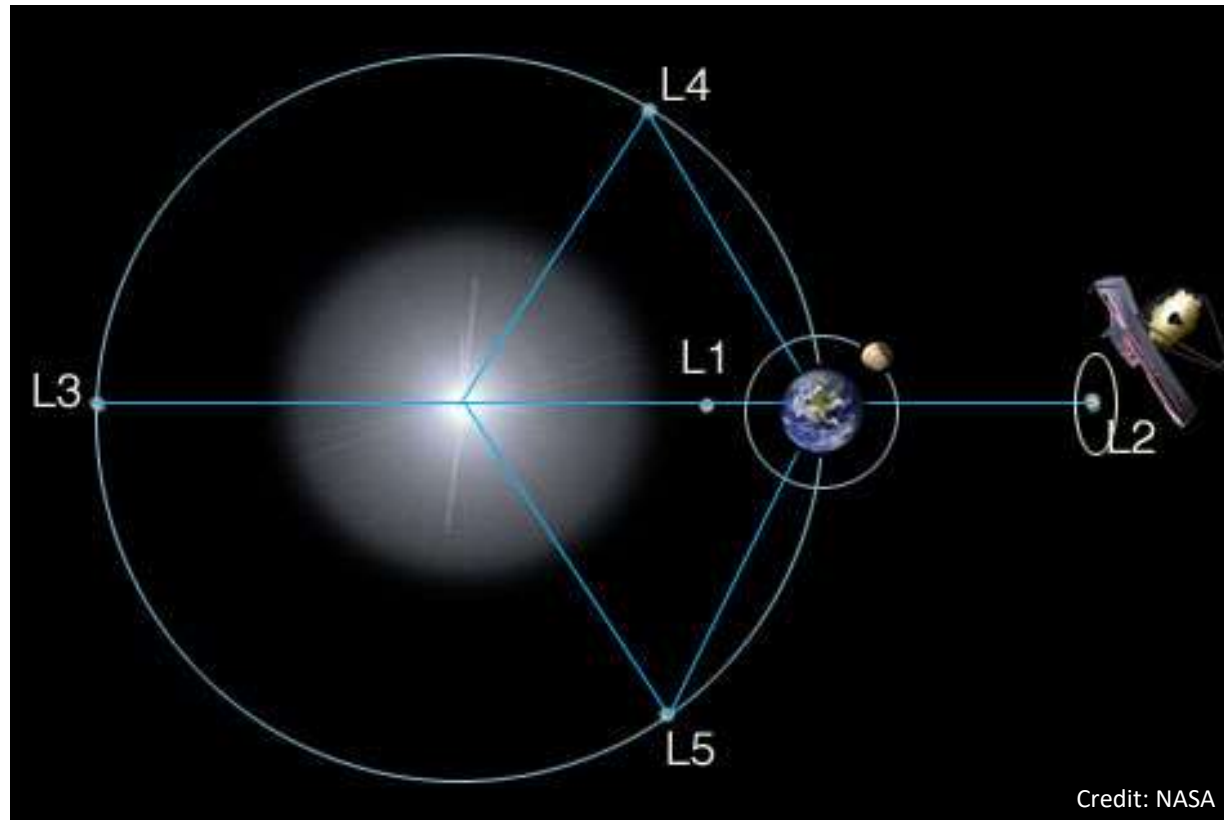

- Effective **cooling**
- **Constant distance** enables data rate to be maintained with the same large ground antennas (DSN)
- Astronomical targets are visible for long periods of time once/twice a year
- L2 is an unstable equilibrium point: **no debris!**

# Where will it be launched from?

- Launch vehicle will be an **Ariane 5** rocket, supplied by ESA
- Launch site will be the Arianespace ELA-3 launch complex near Kourou, French Guiana (more momentum + orbit inclination)





# Primary mirror segment assembly

Credit: NASA/Chris Gunn



# Primary mirror segment assembly

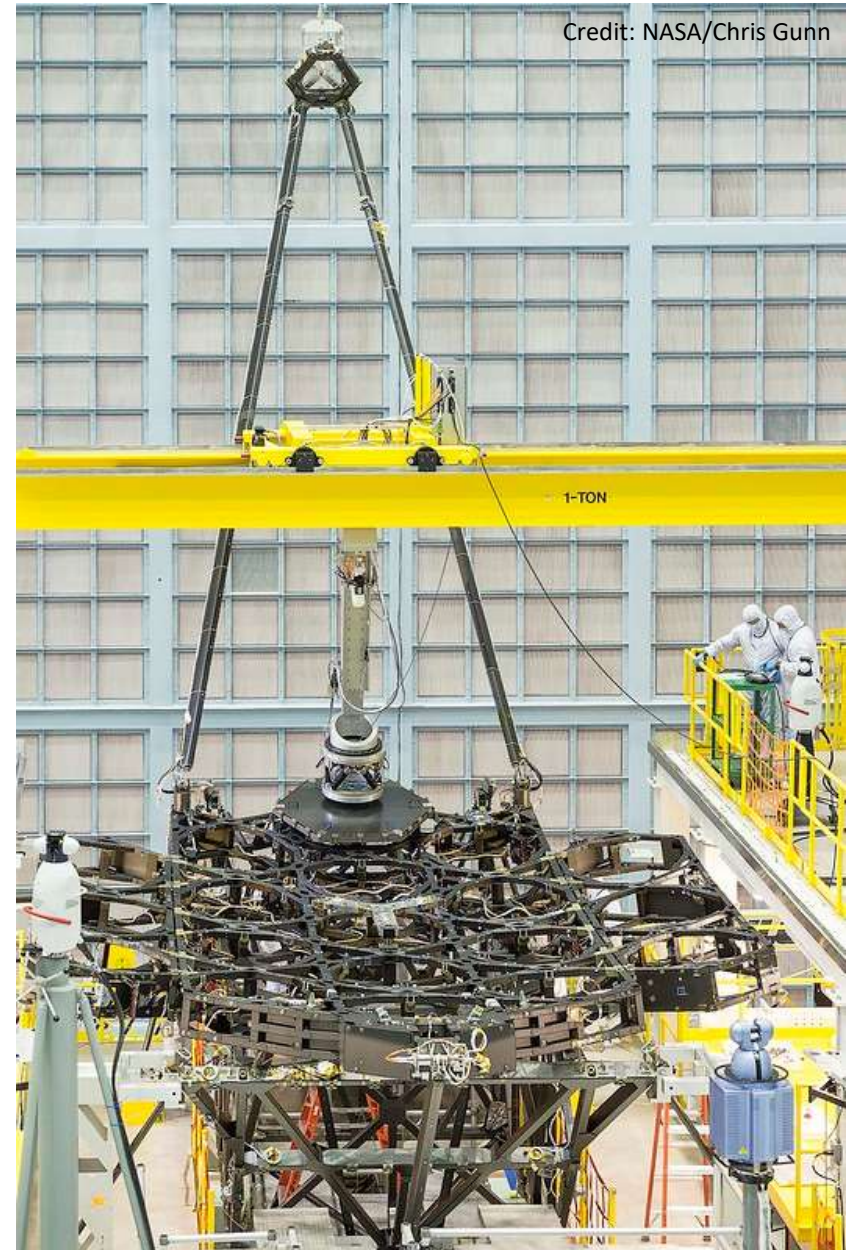

# Primary mirror completed!

Credit: NASA/Chris Gunn

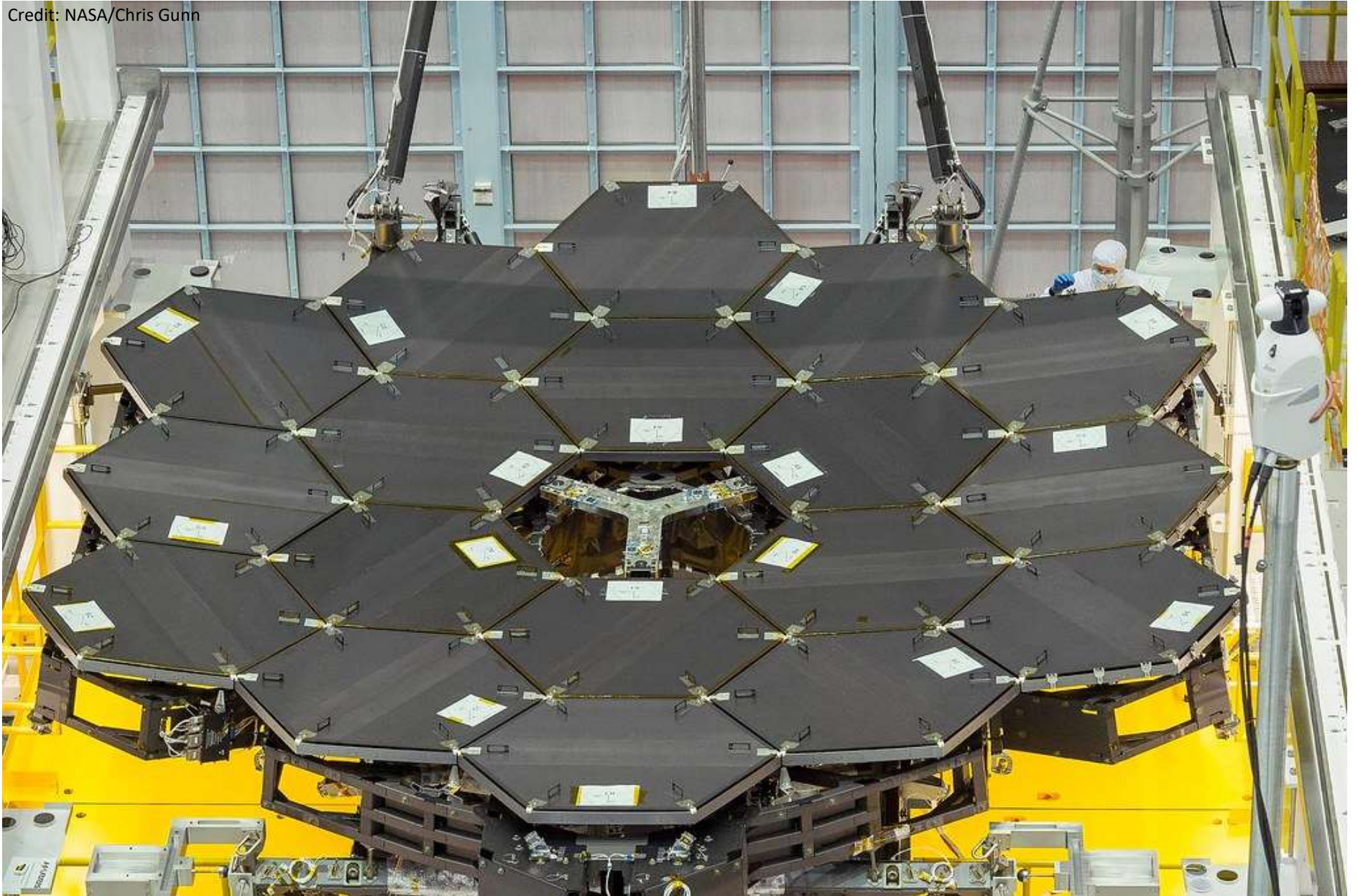

# Primary mirror completed!

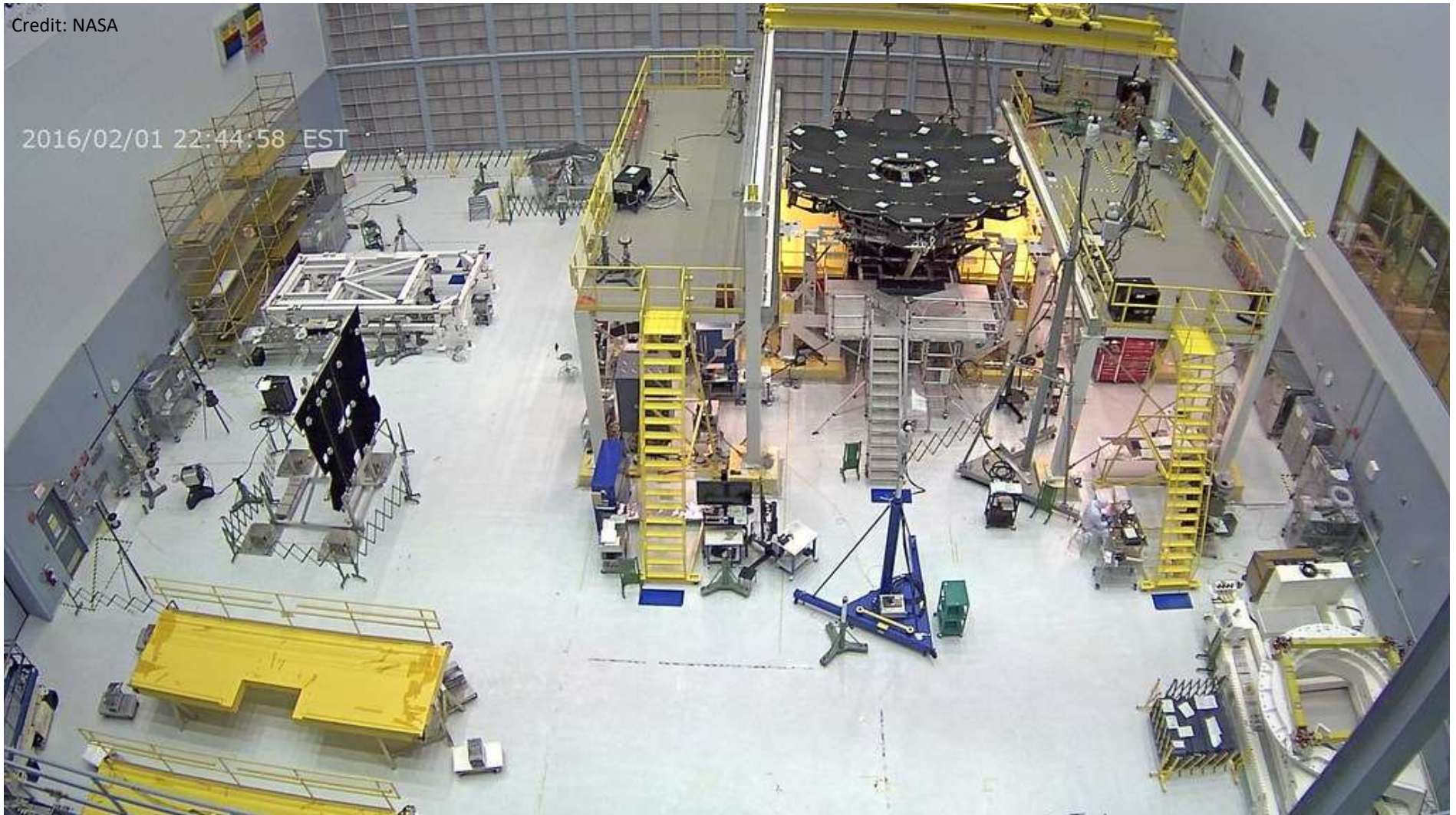

Now, let's uncover them



Credit: NASA/Chris Gunn

Here it is!

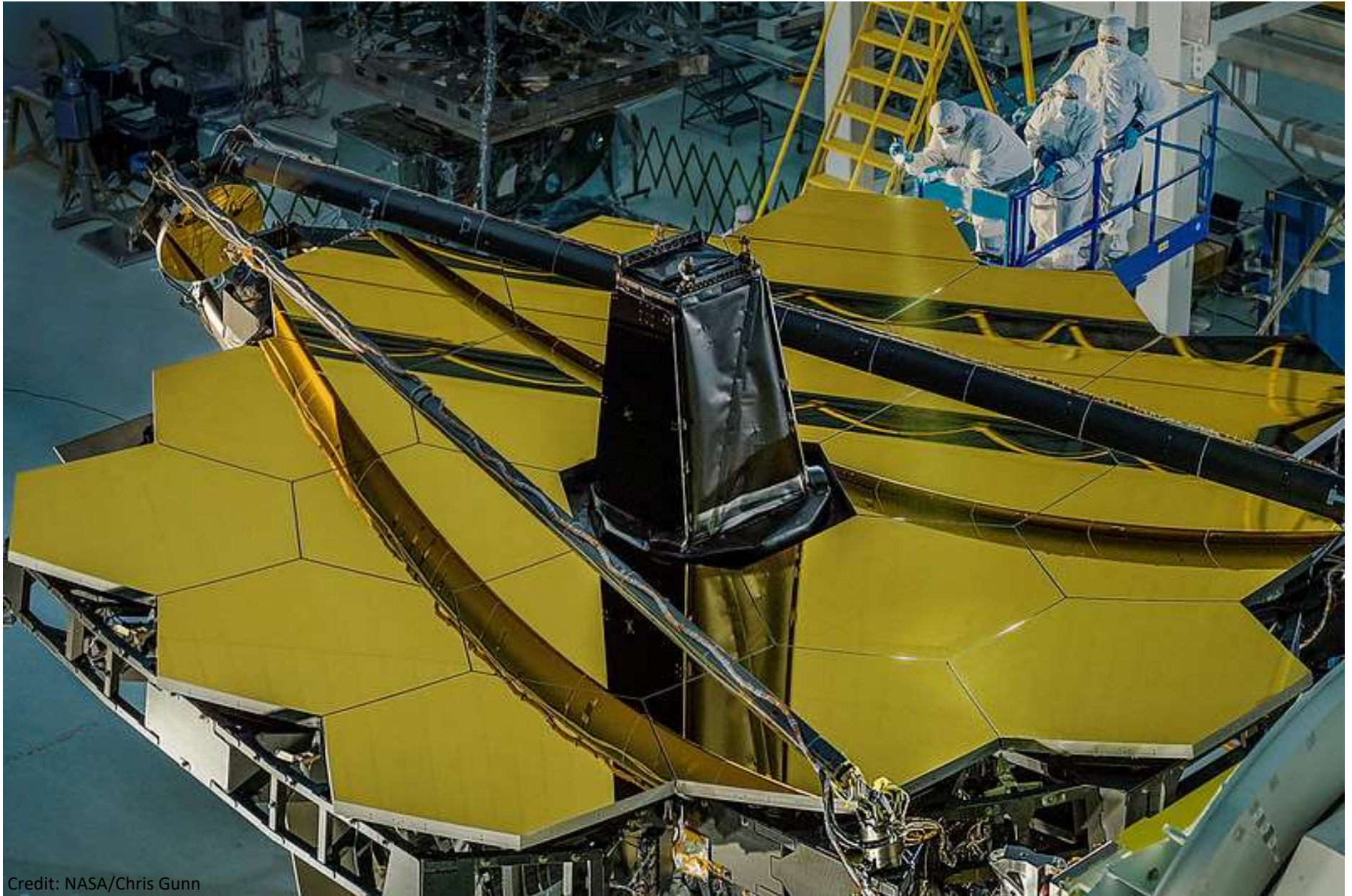

Credit: NASA/Chris Gunn

# Never give up on your dreams



# Vibration testing (2017)





Time to say goodbye...



Destination: HOUSTON  
(Hopefully we won't have  
any problems!)

# Following in Apollo's footsteps

Credit: NASA/Desiree Stover



# JWST and its test challenges

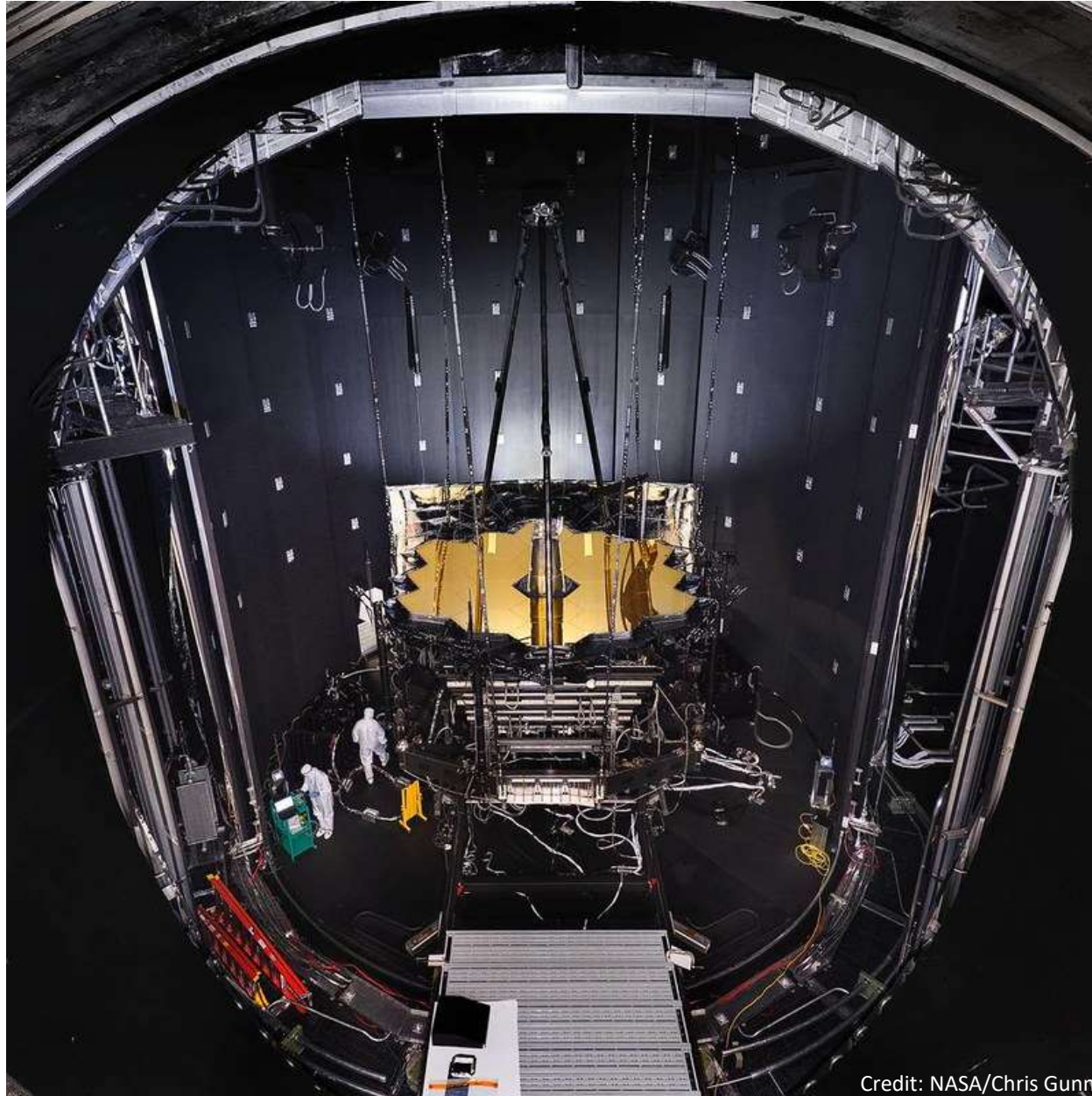

# How to address these challenges?

By developing engineering performance models and validating them by comparing test measurement data with model predictions.

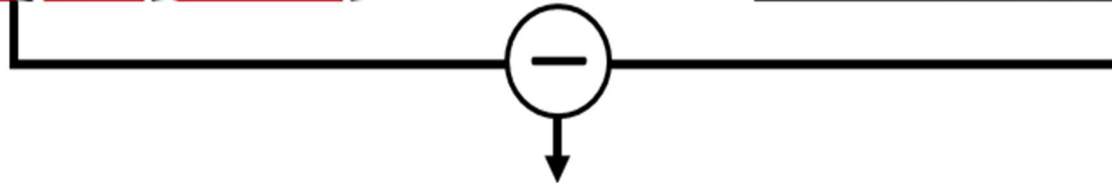
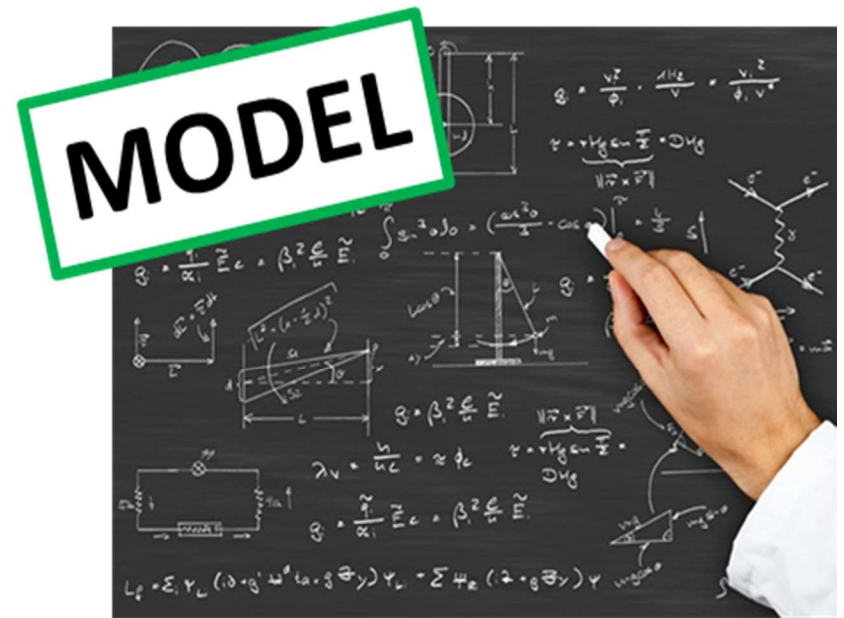

Minimize  $\Delta T = \text{Measured test data} - \text{Model predictions}$



# Model must be validated

- Model **validation** is the process of confirming a model is an adequate representation of the physical system and is capable of predicting the system's behavior accurately with respect to the requirements within the domain of the intended application of the model [1].

- Different approaches:

## Model parameter **fine-tuning** ("Trial and error")

- Based on engineering **expertise** and **intuition**.
- In many government and industrial settings, this is accomplished **manually**.
- **Time-consuming**, with no guarantee of having minimized the error.

## Model parameter **optimization** (Cataldo et al., 2017)

- **Best parameters** and **model predictions** found based on mathematical grounds.
- Computationally **efficient** and **fast**.
- Model parameters are calibrated to match the **experimental data** instead of capturing the true physics of the real system.

- Model **inadequacy** and **uncertainty** are not captured.
- **Margins** are applied downstream of the model to the worst-case predictions.
- Result: **systems can be overdesigned and project resources misused!**

# Uncertainty must be incorporated upstream

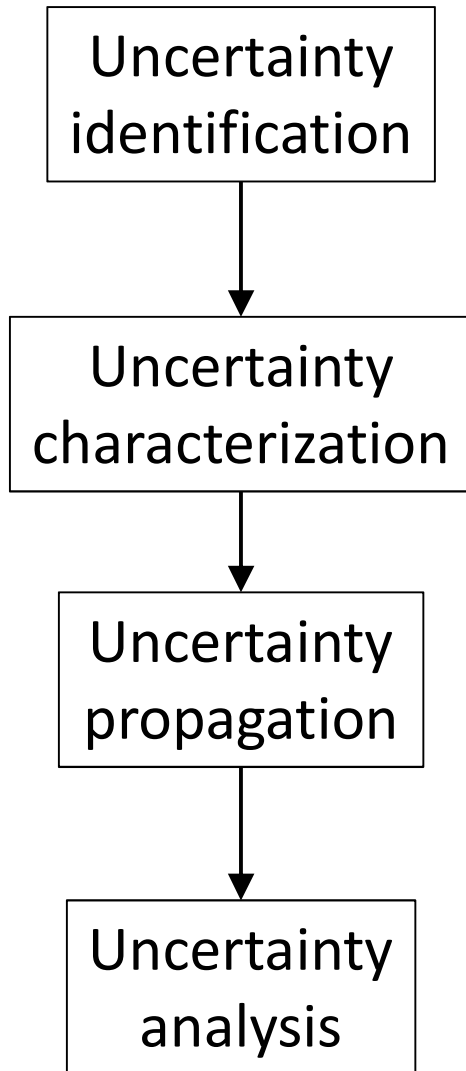

- Parameter uncertainty, model inadequacy
- Observation error
- Code uncertainty
- Aleatory/epistemic uncertainty
  
- Gather data from the literature or actual measurements
- Subject matter experts
- Assign uncertainty distributions to all model parameters, including model inadequacy
  
- (Quasi) Monte Carlo simulations
- Adopt a multi-fidelity approach for speed-up
  
- Global sensitivity analysis (work of J. Auclair, 2019)
- Bayesian inference (S. Bouriat, 2019)
- Model inadequacy (S. Bouriat, 2019)
- Optimization under uncertainty

# Variance-based Sensitivity Analysis

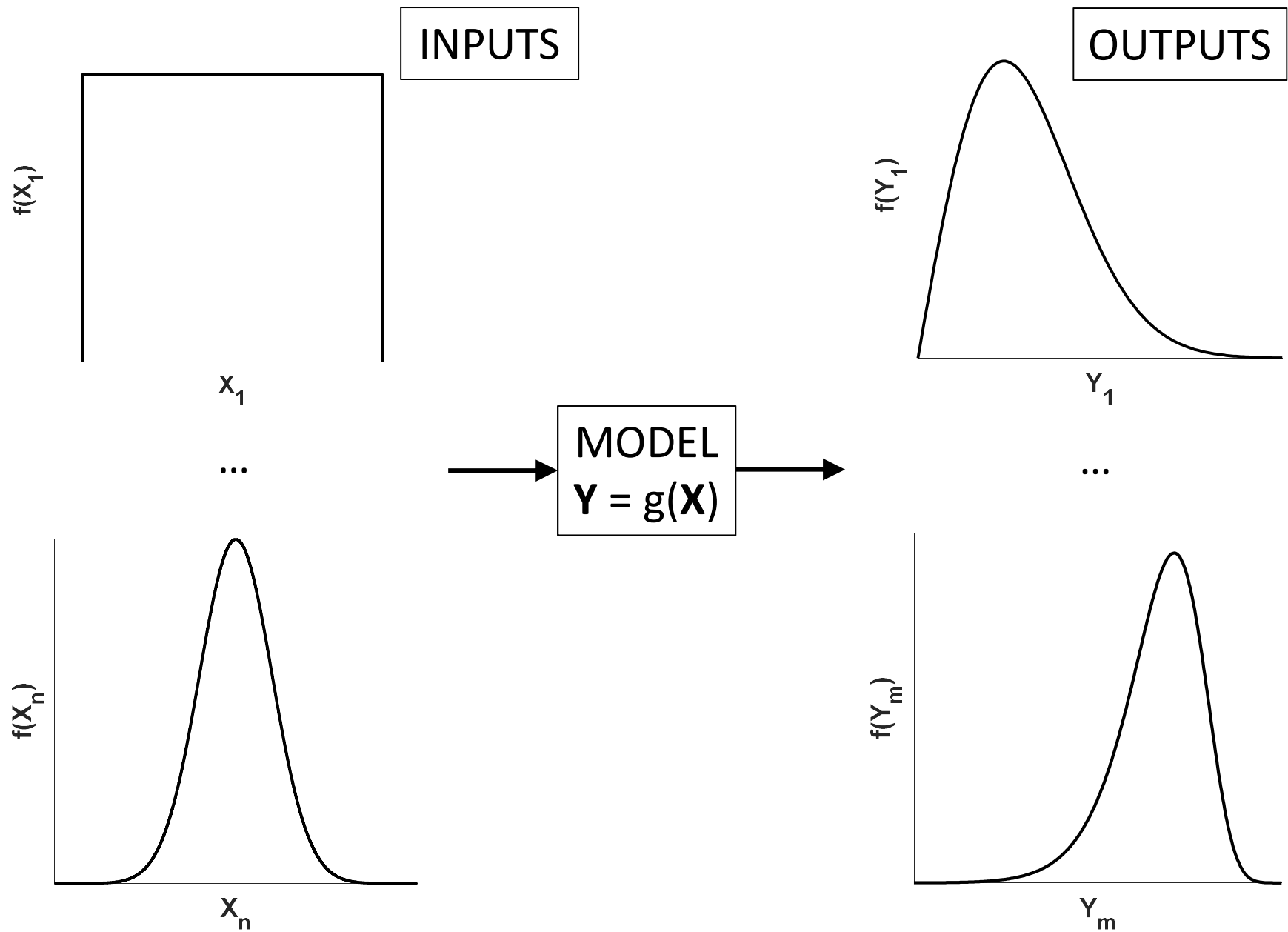

# Variance-based Sensitivity Analysis

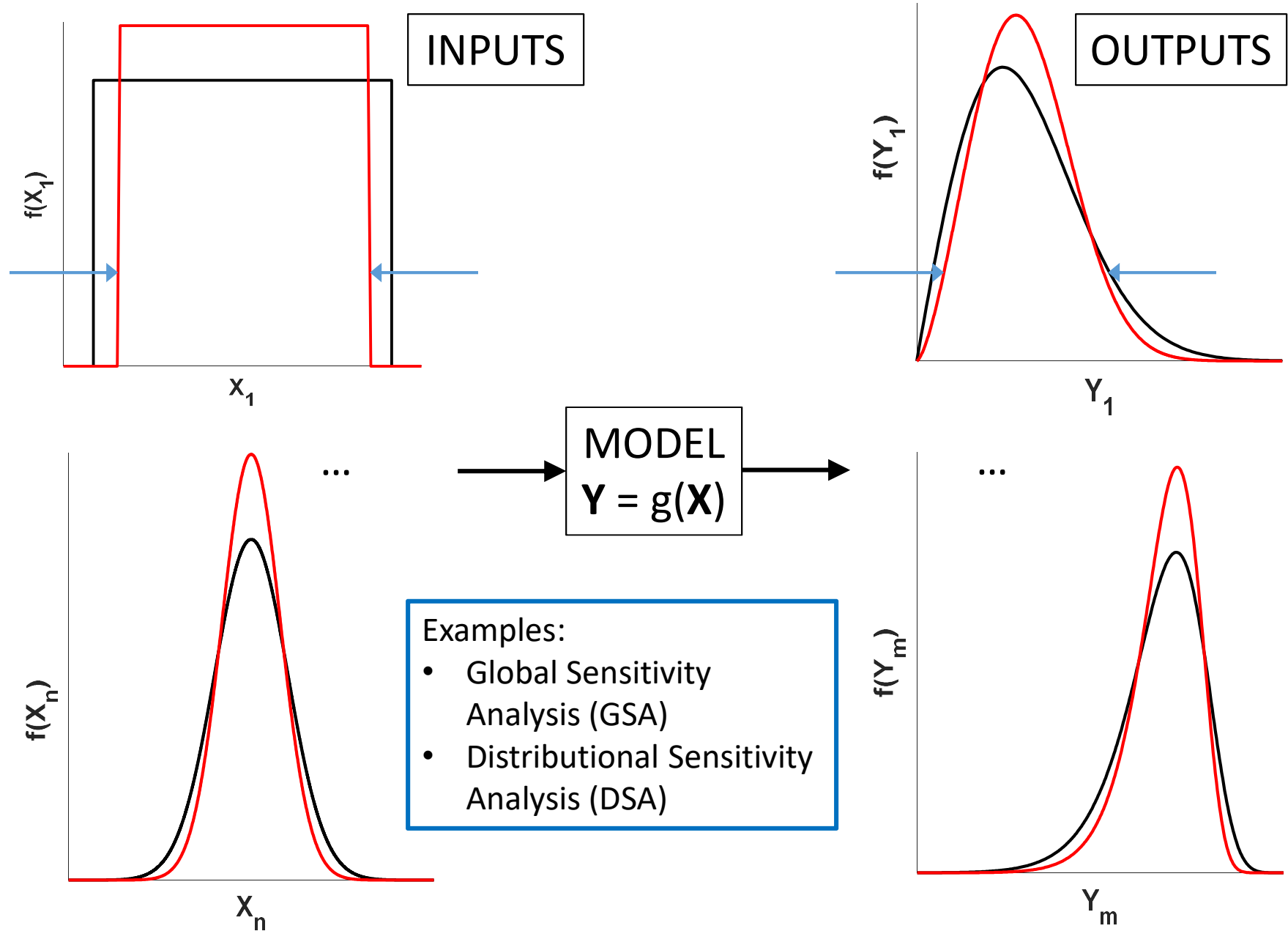



# GSA can help reduce output variance

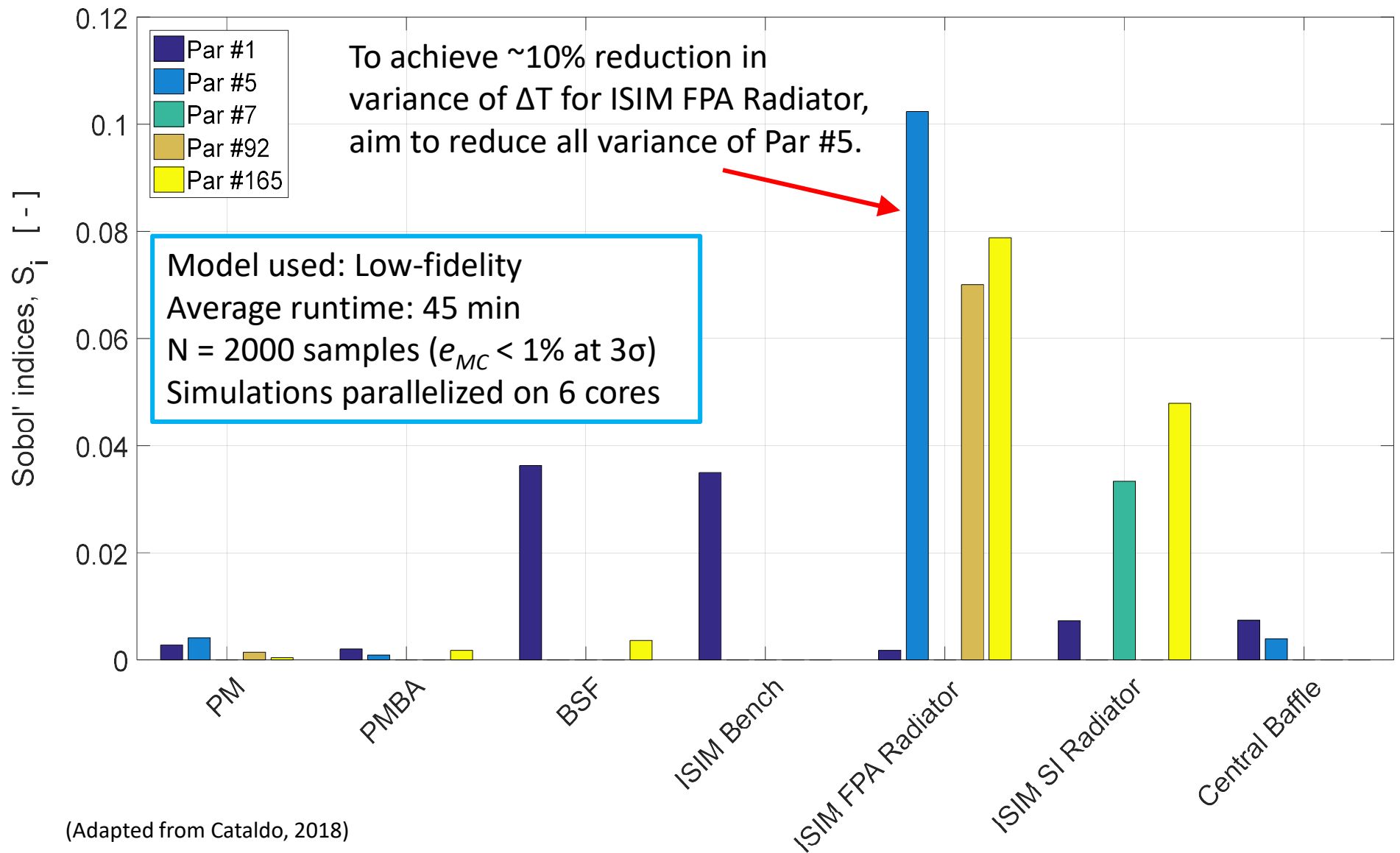

(Adapted from Cataldo, 2018)

# Design of Experiments and Bayesian Inference

- Focus on parameters with greatest variance to design parameter inference experiments in order to **reduce their variance**.
- Perform experiment (e.g., optimal, optimal-Bayesian).
- Update priors with Bayes' theorem to get the **posterior** distributions, i.e., the uncertainty distribution that has been updated based on new information (e.g., experimental data).
- Iterate the entire process with updated information.

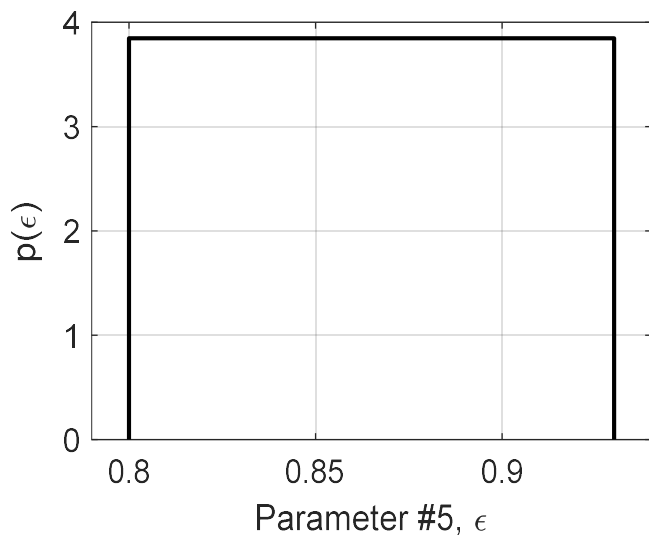

BAYES'  
THEOREM

→

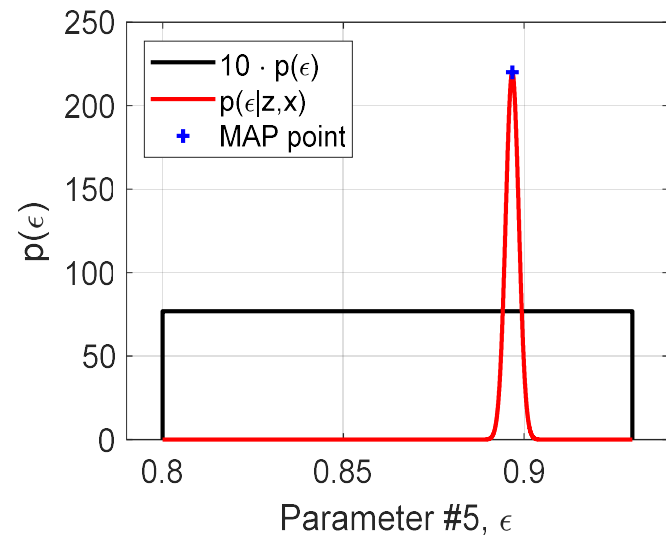

# Multi-fidelity: speed up and stay accurate

## High-fidelity model

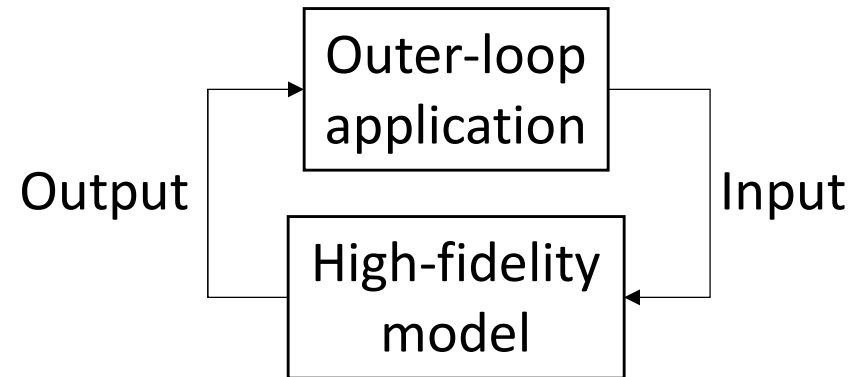
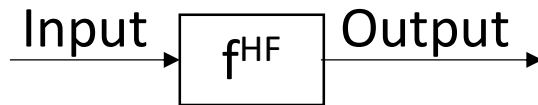

## Low-fidelity models

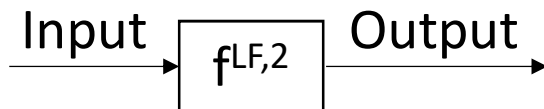
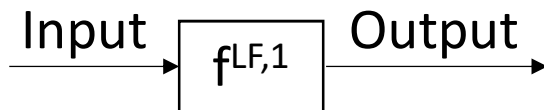

⋮

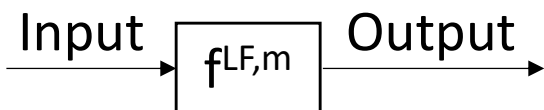

- Invoke multiple models to **reduce computational cost**
- Maintain **accuracy guarantees** on outer-loop results

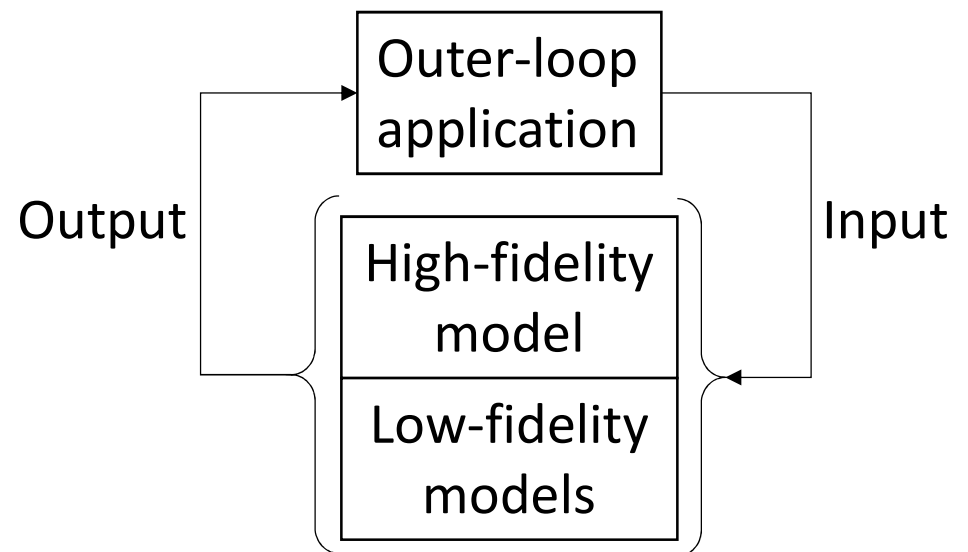

# Ongoing and future work

A **multi-fidelity** approach that leverages several types of low-fidelity models to speed up UQ tasks, while having recourse to the high-fidelity model to guarantee accuracy.

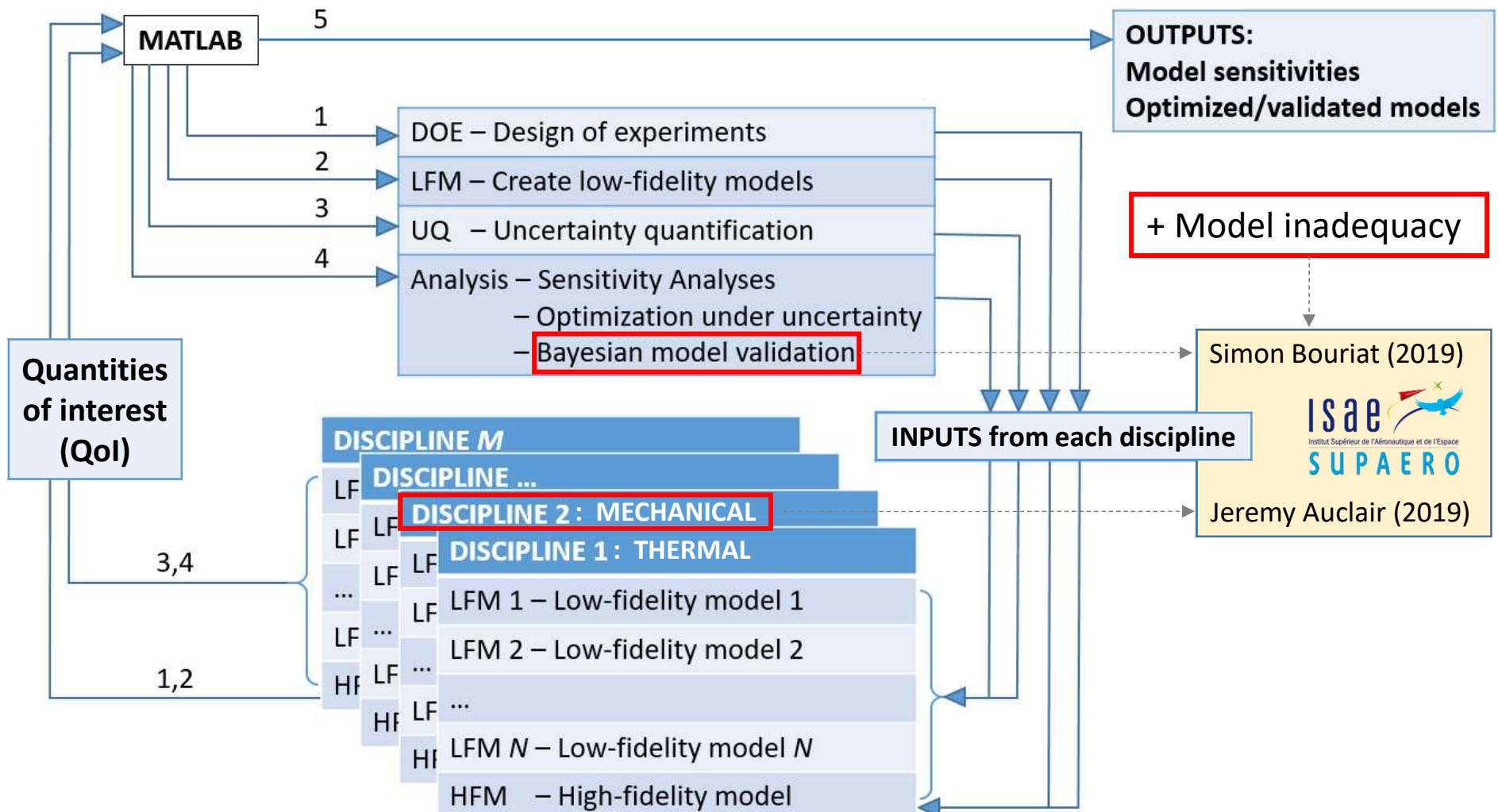

# In the meantime, in California...

Credit: Northrop Grumman



# Secondary mirror deployment test

Credit: NASA/Chris Gunn



# Current status: final integration

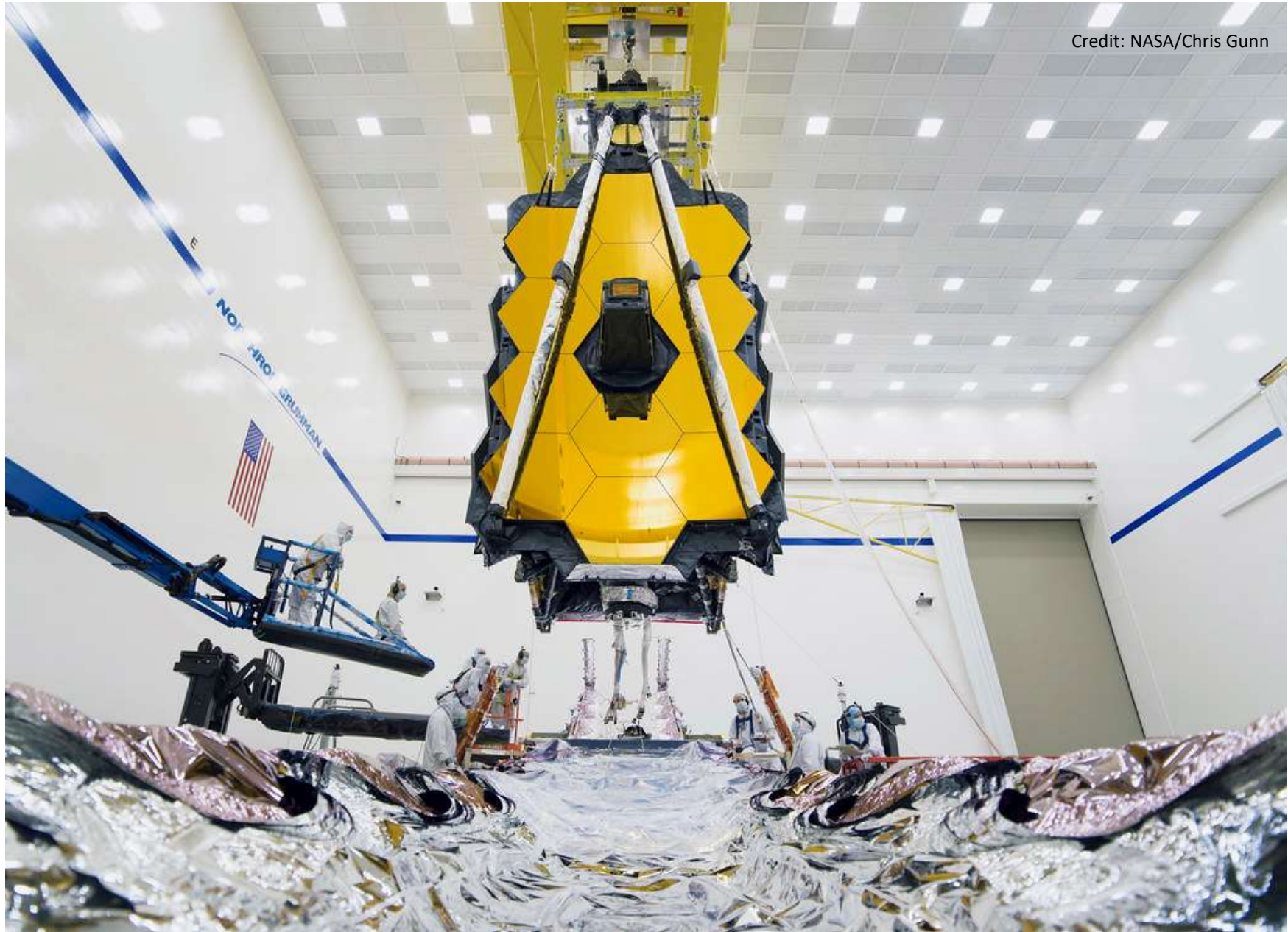

# Current status: final integration





# Next steps

- Electrical integration
- Environmental testing
- Deployment testing
  - Sunshield
- More testing
- Pre-ship
- Ship to French Guyana
- Launch

# “Heritage” spin-offs



A program in development (Webb) invented a technology for a program well into the operations phase (Hubble).

- ASICs are small, specialized integrated circuits that enable an entire circuit board's worth of electronics to be condensed into a very small package
- Webb's investments into this technology allowed the ASICs to be programmable, which was important in the repair of Hubble's Advanced Camera for Surveys that has produced stunning views of our universe

# Technological spin-offs

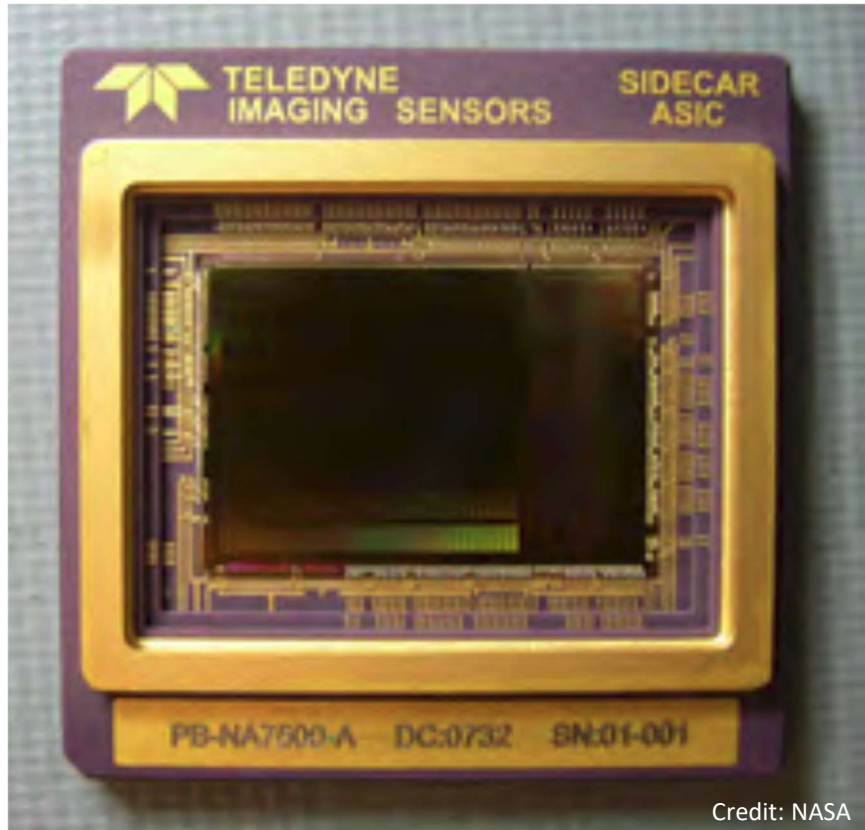

- Infrared sensors based on the technology developed for JWST are now the **universal choice for astronomical observations**, both from space and the ground
- This technology is also being used for **Earth science and national security missions**

# Commercial spin-offs

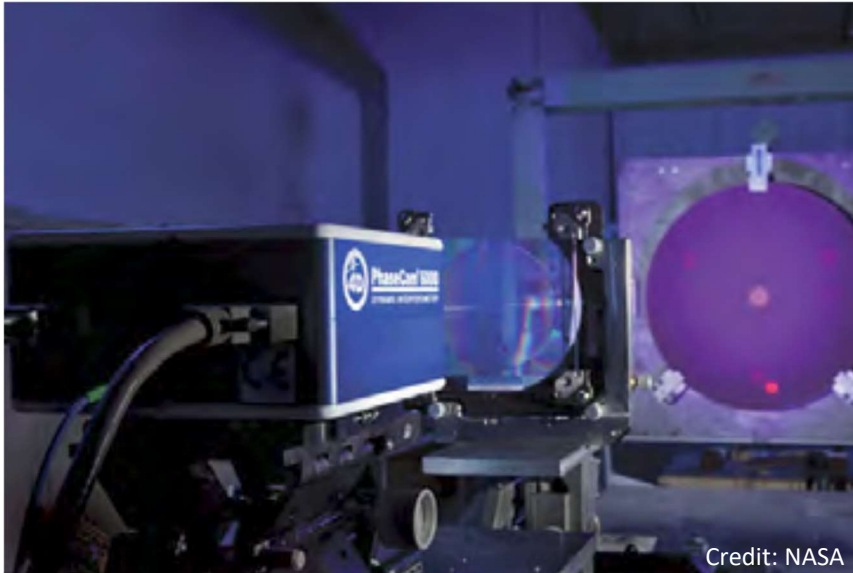

According to 4D Technology CEO James Millerd, “The JWST program has been a tremendous benefit to **creation of new technology and jobs beyond its direct funding**... 4D has gone on to generate over \$30 million in revenue from a wide range of applications within the **astronomy, aerospace, semiconductor and medical industries** based on the technologies developed for JWST.”

- One of the toughest challenges was to find a way to test mirrors and composite structures at the incredibly cold  $-450^{\circ}\text{F}$  temperature they will operate in space
- With desired precisions of nanometers, vibration is a constant problem. To solve that problem, several new types of **high-speed test devices** were developed that utilize pulsed lasers that essentially “**freeze out**” **the effects of vibration**

# Medical spin-offs

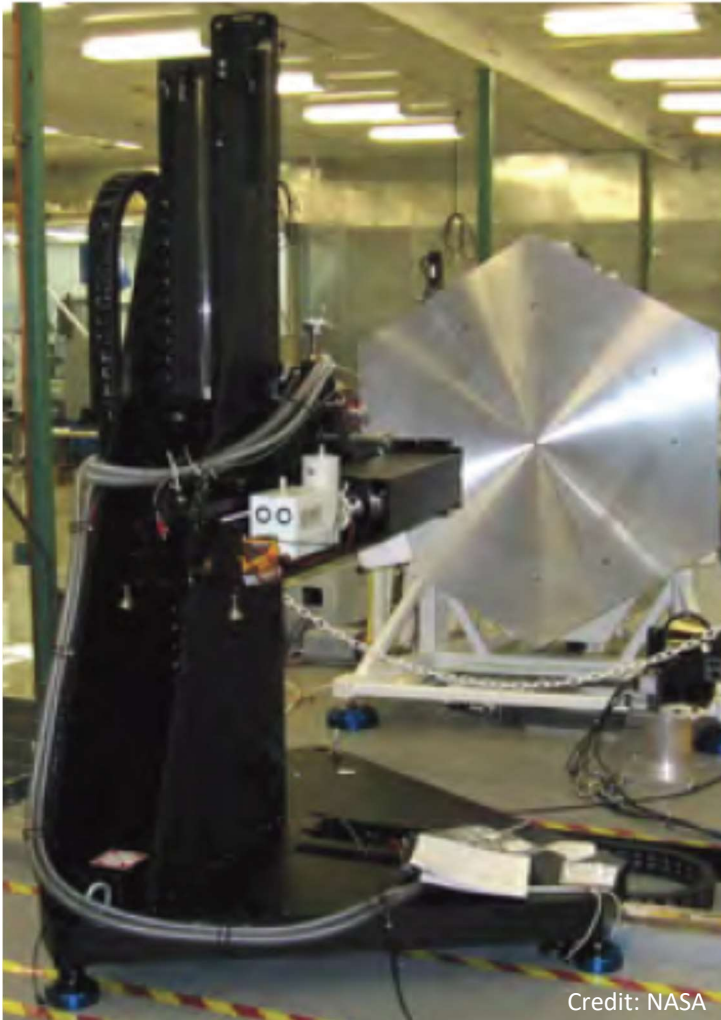

- A number of improvements in technology used for measurement of human eyes, **diagnosis of ocular diseases** and potentially **improved surgery**
- Enabled eye doctors to get much more detailed information about the **shape of your eye** in seconds rather than hours
- Four patents have been issued as a result of innovations driven by the JWST program

<http://www.jwst.nasa.gov/>  
[@NASAWebb](#)

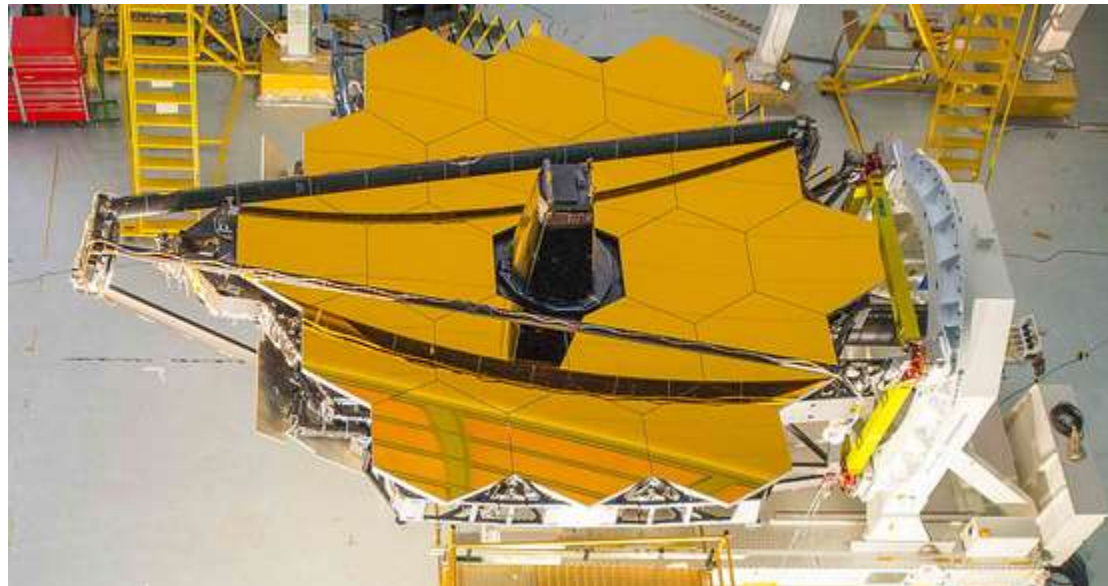

For further information:  
[Giuseppe.Cataldo@NASA.gov](mailto:Giuseppe.Cataldo@NASA.gov)