

# Textile Antennas for Space Environment

NASA Johnson Space Center

Presenter: Ami Yang

10/16/2019



Trade names and trademarks are used in this report for identification only. Their usage does not constitute an official endorsement, either expressed or implied, by the National Aeronautics and Space Administration.



# Agenda

- Overview
  - NASA motivation for e-textile antennas
  - Development and history
- eXploration Extravehicular Mobility Unit (xEMU) project
  - xEMU antenna and current EMU antenna comparison
  - Challenges of e-textile antenna in extreme space environment
- Prototype design, test results and lessons learned
- Design Verification Test Unit (DVTU)
- Textile antenna for sensing application
- Forward work
- Conclusion



# Motivation for E-Textile Antennas

- Antennas represent low-hanging fruit for e-textile circuits
  - Core physics link antenna aperture area to performance
- MIMO communications
  - Low encumbrance for spacesuits
- Wearable antennas
  - Wireless sensor tags and interrogators
- Wireless, no-battery sensors
  - Mass reduction for spacecraft
  - Eliminates power and data wires
- Structure-integrated antennas
  - Inflatable habitats



40 ft inflatable toroidal habitat

CIF IRAD Project Management:  
• Raymond Wagner / EV8  
• raymond.s.wagner@nasa.gov, x42428

Ultra Long-Lived, Self-Surveying Autonomous Air Quality Sensing  
Year: 3 of 3

Supplemental Page 3

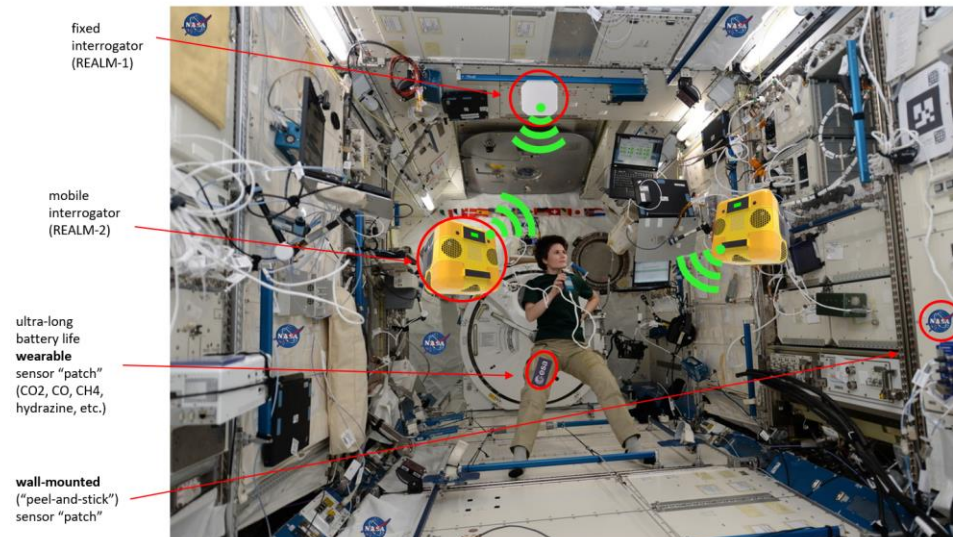



# E-Textile Development Overview



Nora/Nora Dell (Shieldex)



Fabric equiangular spiral antenna

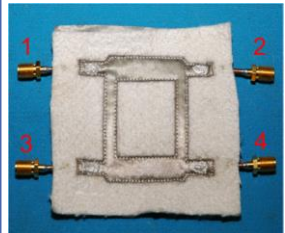

Fabric hybrid coupler

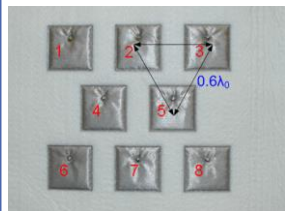

fabric array antenna



Epilog laser engraving and cutting machines are used to remove excess conductive material



MELCO embroidery machines used to attach conductive fabric to dielectric material

World class Softgood's Lab



Computational Electromagnetics (CEM) Tool for Optimal Antenna Placement

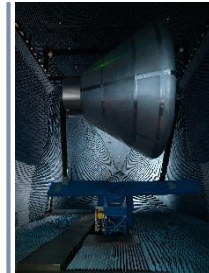
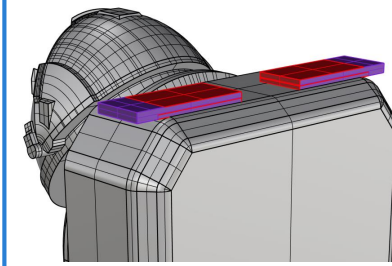
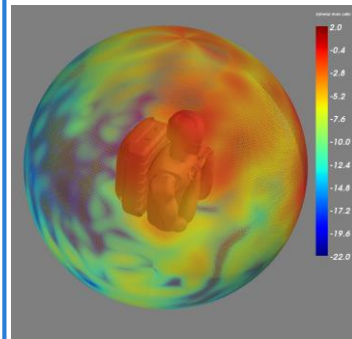
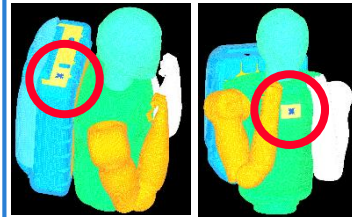

Antenna Test Facility



Vacuum Test



Thermal Test



Robonaut 2 IVA: 2011



REALM 2 IVA: 2019



xEMU EVA: 2023 Lunar Surface: 2024



Research

Manufacturing process

Analysis

Testing

Flight Opportunities

10/1/2019



# xEMU Overview

- xEMU is broken into
  - xPLSS - Portable Life Support System
  - xPGS - Pressure Garment System
  - xINFO – Informatics
- xDEMO
  - One suit ready for delivery to International Space Station by 2023
- Lunar Surface
  - Two suits ready for delivery by 2024

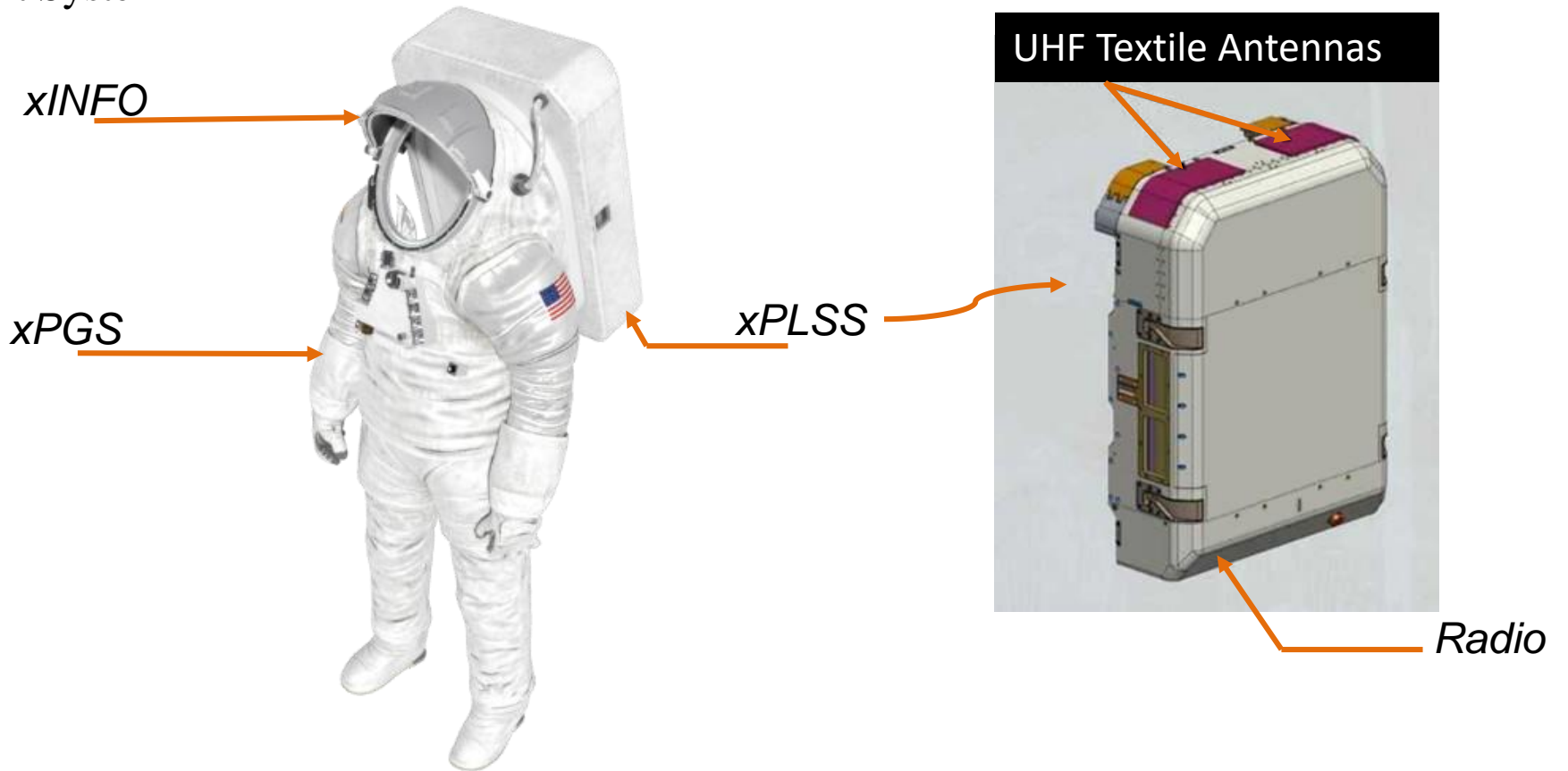



# Prototype Design Compared to EMU Antenna

- The motivation for the new antenna design is to reduce mass and volume while maintaining good antenna performance, satisfy EVA requirements, and increase redundancy of the system.

	EMU Antenna	xEMU Antenna
# of antenna	1	2
Frequencies	Prime: 414.2 MHz BU: 417.1 MHz	Prime: 414.2 MHz BU: 417.1 MHz
Volume	3.5" x 10.225" x 0.75"	3.5" x 8" x 0.65" per antenna
Mass	445 grams (1lb)	37 grams (.08lb) per antenna



EMU Antenna

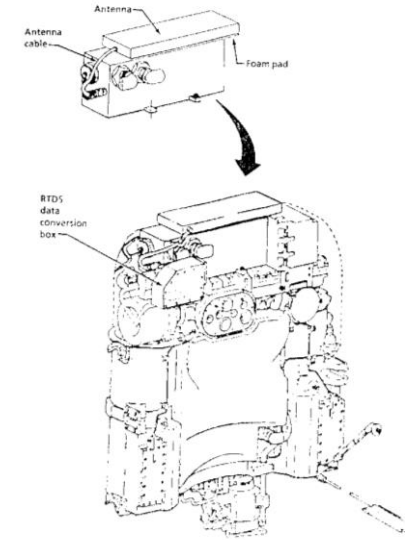

UHF Textile Antennas





# EVA Challenges for Textile Antenna

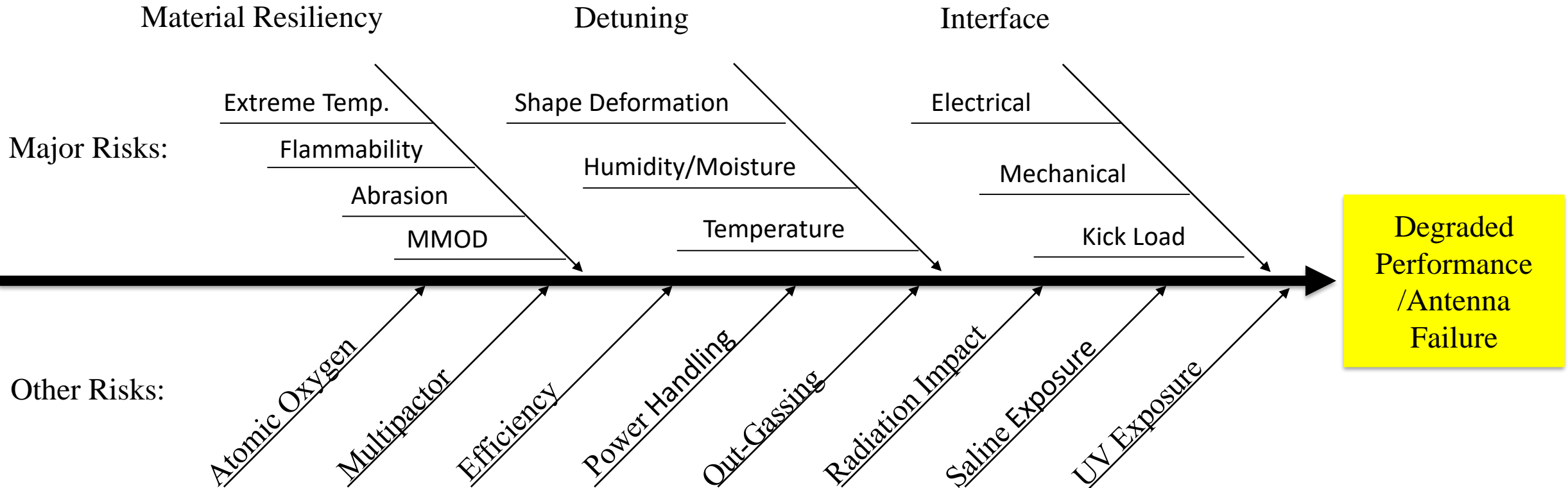



# Prototype Design

- Prototyping started in October, 2018
  - Stacked Quarter wave E-Textile Patch Antenna: dual resonance to minimize possibility of detuning
  - Bandwidth: 405MHz to 425MH
  - Probe Feed
    - Feed structure constructed using Rogers 6002 PCB material and secured by PEEK screws



Top Patch



Bottom Patch

10dB = ~ 90%  
power to antenna

### Return Loss Measurement

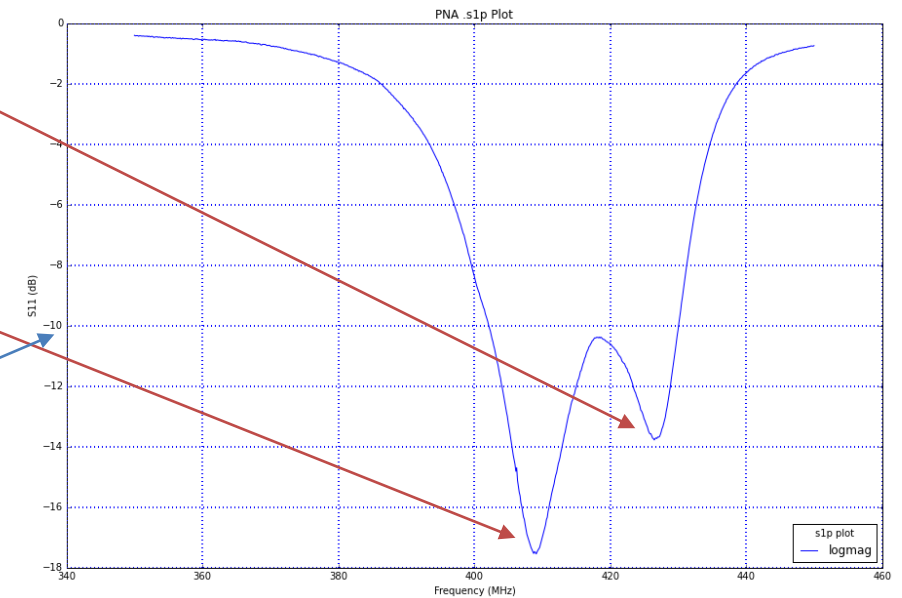





# Prototype Evaluation

- Material Evaluation
  - Conductivity (Measurement)
  - Abrasion (Measurement)
  - Thermal (Test)
- Antenna Evaluation
  - Thermal Test
    - Number of Cycles: 5
    - Low Extreme: -250F
    - High Extreme: +250F
  - Load Test
    - 125 lb kickload force over a 4 inch x 4 inch area
    - Dynamic load
  - Pattern Measurement
    - Antenna pattern over 4' x 4' ground plane
  - CEM Analysis
    - Verify antenna CAD model
    - Find optimal antenna placement
    - MMOD impact
  - Coverage Analysis
    - ISS External EVA

Test Item	Title	Description	Result
1	Material Evaluation	Select material best suited for E-Textile antenna	Nora/Nora Dell by Shieldex
2	Thermal Test	Antenna maintains good performance through thermal cycles	Minimum impact to performance, but more testing needed in bigger thermal vacuum chamber
3	Load Test	Antenna survive 125 lb. kickload force over a 4'' x 4'' area and a dynamic load	No major damage on antenna surfaces. However, SMA connector interface will need protection
4	Antenna Pattern Measurement	Antenna pattern satisfies the gain requirements	Antenna gain satisfied the gain requirements
5	CEM Analysis	Verify antenna CAD model accurately represent hardware	Simulated pattern and measured pattern show good agreement
		Select antenna mounting position	Two antennas must be mounted at least 5'' apart to obtain -10 dB isolation
		0.25'' MMOD holes were simulated at various locations on the antenna	No major distortion to antenna patterns
6	Coverage Analysis	Coverage Analysis	ISS EVA comm is expected to have positive margins in most of the translation paths and worksites



# Material Selection

- Materials
  - Pure copper polyester taffeta fabric
  - Nora
    - Rip Stop
    - Plain Weave
    - Nora Dell
  - Monel 400
  - 304 stainless steel mesh
- Surface resistivity measurement performed to compare the samples. Nora Dell was selected for having the lowest surface resistivity.
- Thermal cycle had minimal impact on material resistivity.



Nora@50x before thermal cycle

Nora@50x after thermal cycle



# Thermal Cycle Test

- Applied static and dynamic loads over antenna surface during thermal cycle.
  - Permanent deformations observed in the material, but no impact to antenna performance.
- Return loss measurement performed during thermal cycle to evaluate antenna detuning due to temperature changes.



No load applied during thermal cycle

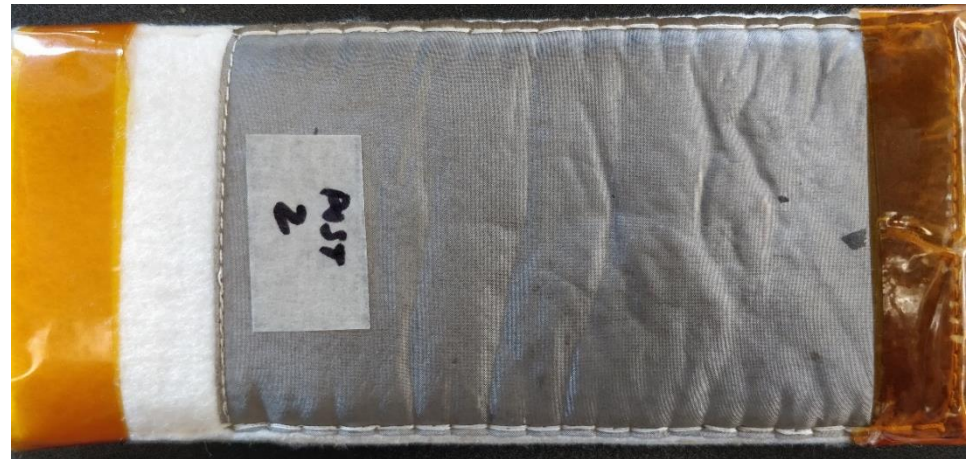

Dynamic and static load applied at -250F



# Prototype Lessons Learned

- As a result of preliminary load test, we learned that the connector interface needs additional protection when the antenna is mounted on top of a hard surface. In addition, connector datasheet recommended operating temperatures are  $-65\text{ }^{\circ}\text{C}$  to  $105\text{ }^{\circ}\text{C}$ .

Pre load test

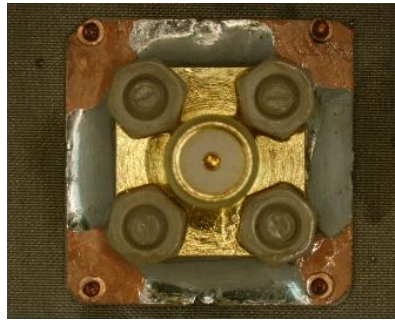

Post load test

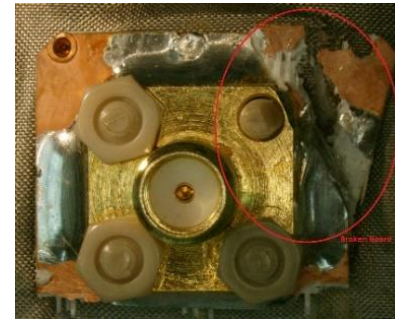

- The next revision (DVTU) we are looking at feeding the antenna with a stripline and moving the connector interface to inside of the PLSS Shell to reduce the risk of connector failure, and easy access for crew. Also looking at replacing SMA with MIL-DTL-38999 connectors.

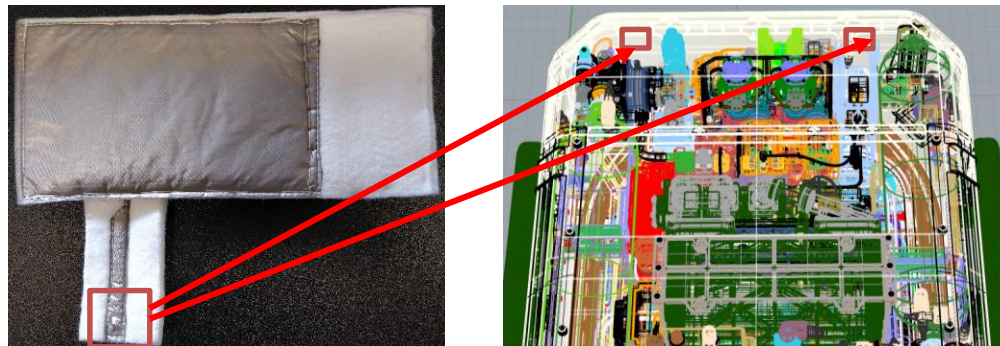



# Antenna Patterns (SSEER vs. SSER)

EMU Antenna Test Facility (ATF) measurement

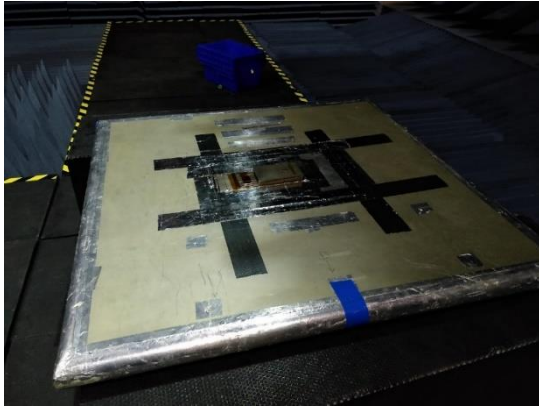

xEMU Antenna Test Facility measurement



1 lbs

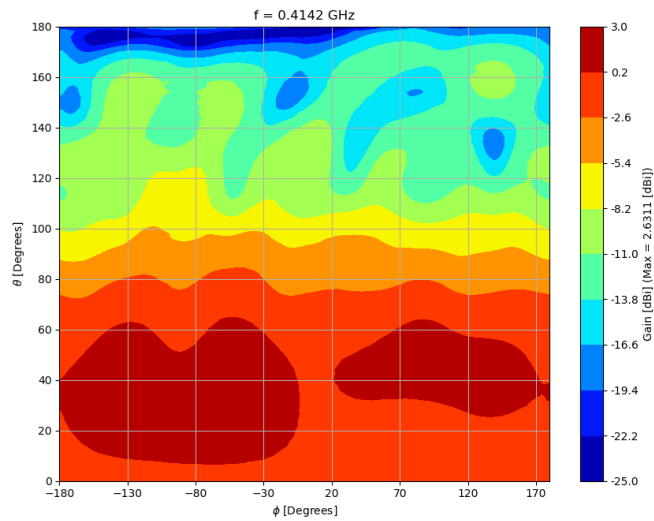

→  
~92% mass reduction



0.08 lbs

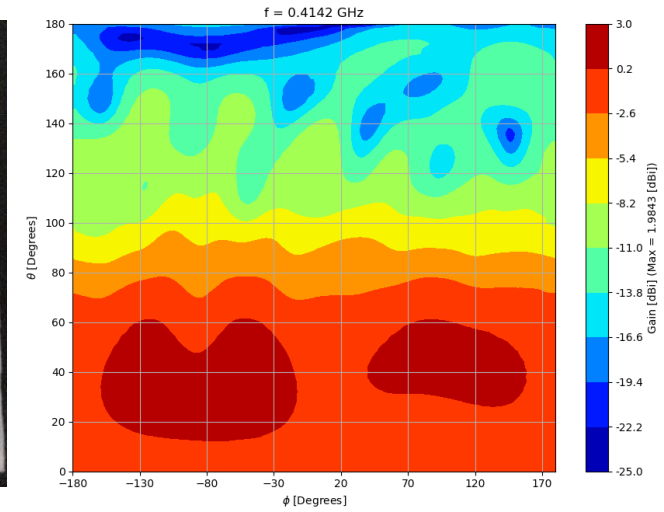



# Antenna Patterns on Space Suit Mock-up

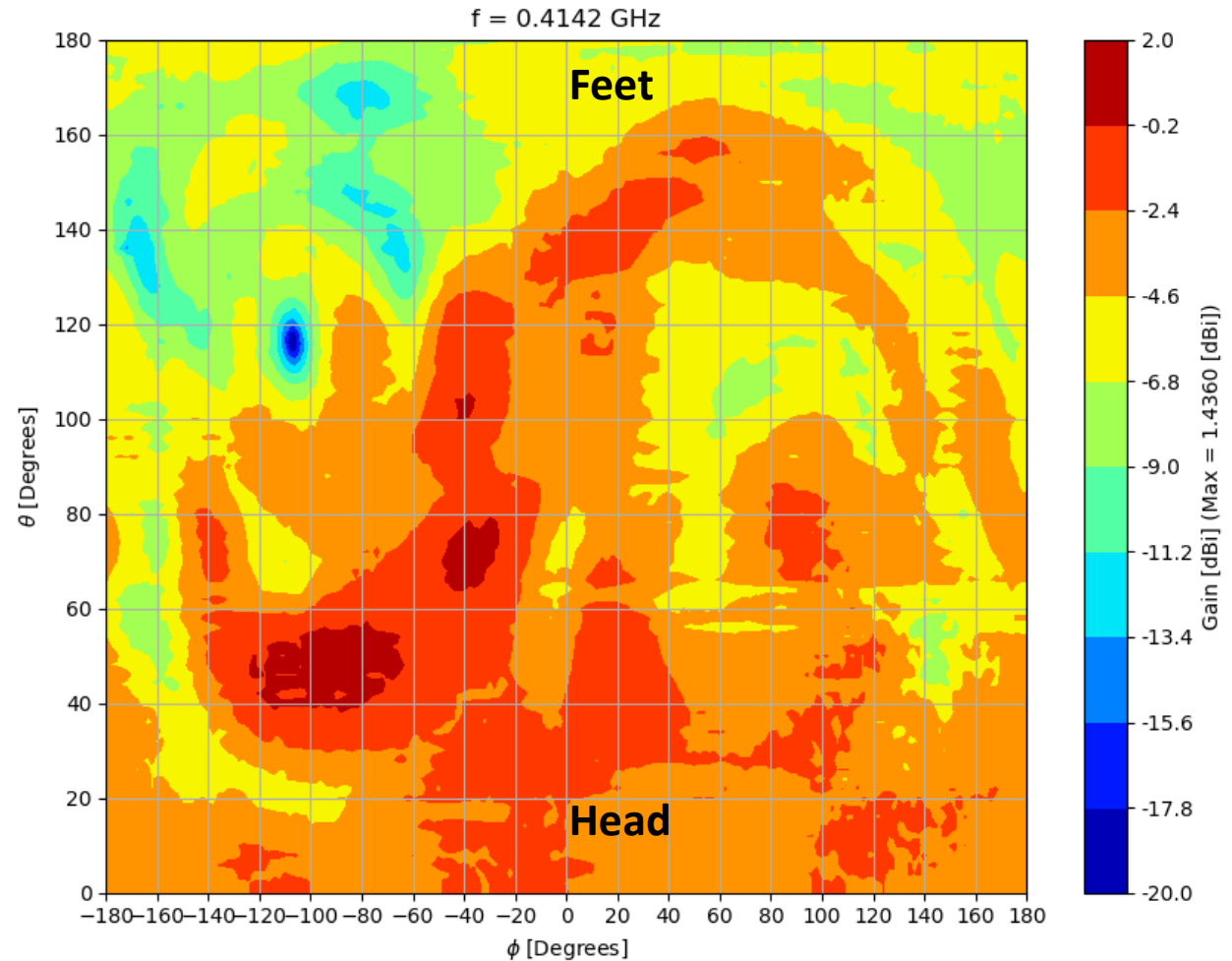



# Prototype Lessons Learned

- As a result of preliminary CEM analysis, we learned that by placing the two antennas next to each other on the top of the PLSS, while only one antenna is active, there is strong coupling between the 2 antennas and will cause distortions in the antenna pattern.

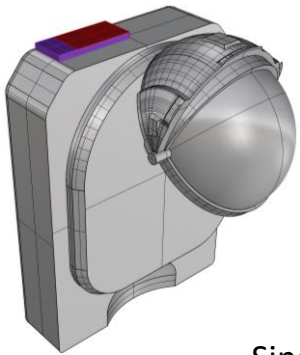

Single Antenna

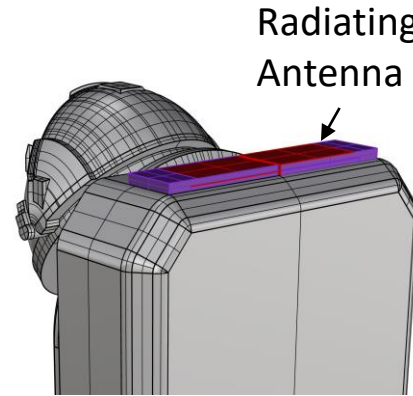
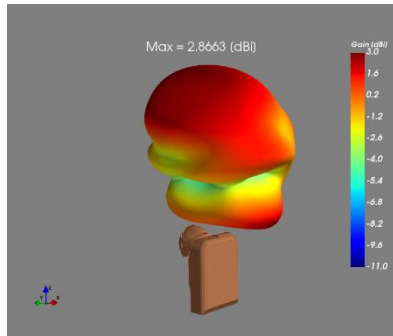

Active and Passive Antenna

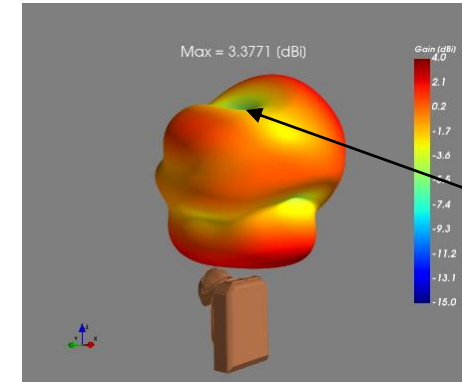

Deep null at boresight

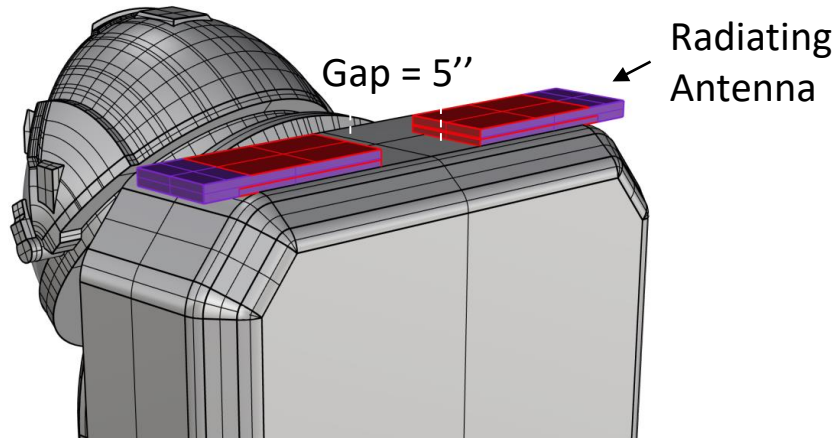

Gap = 5"

Radiating Antenna

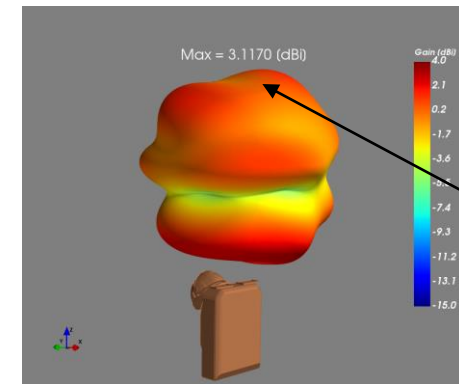

Better gain at boresight



# Coverage Analysis Comparison: EMU

- Comparison of EVA Link Performance: EMU and xEMU
  - during Extravehicular Activities (EVA)

EMU pattern based on measurements on mockup



EMU

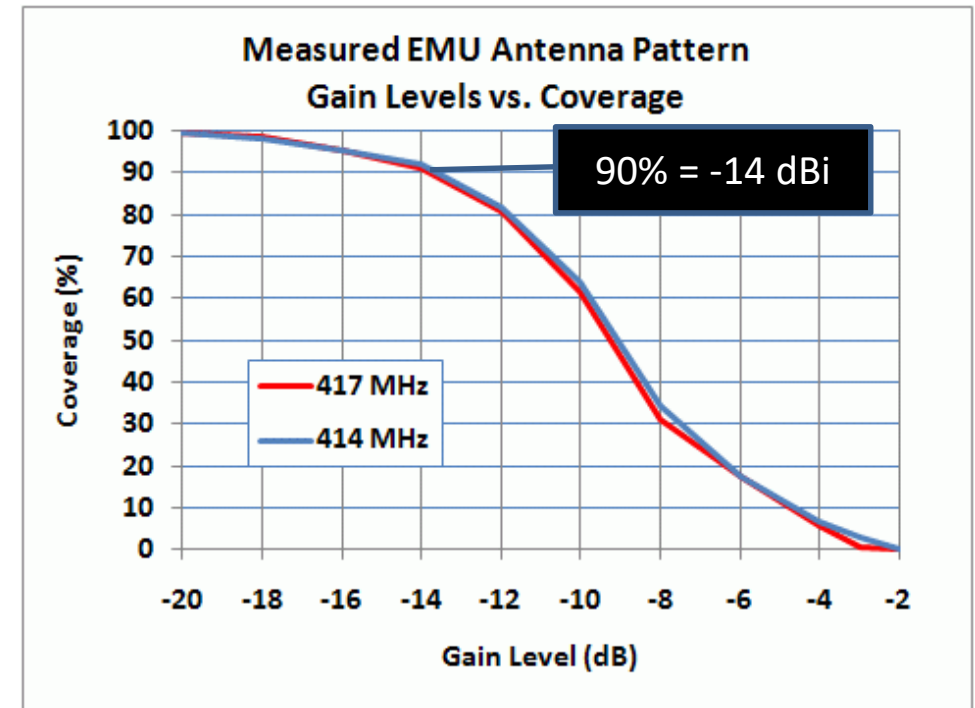





# Coverage Analysis Comparison: xEMU

xEMU pattern based on simulated antenna pattern with PLSS and helmet

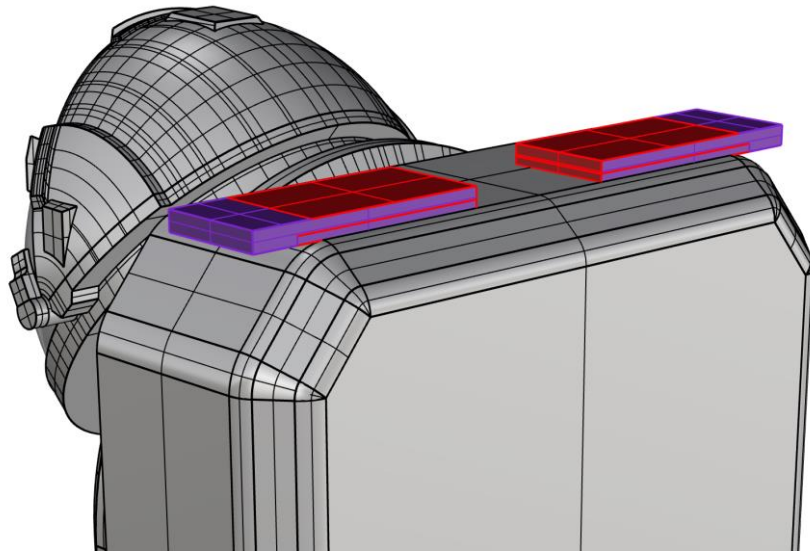

xEMU

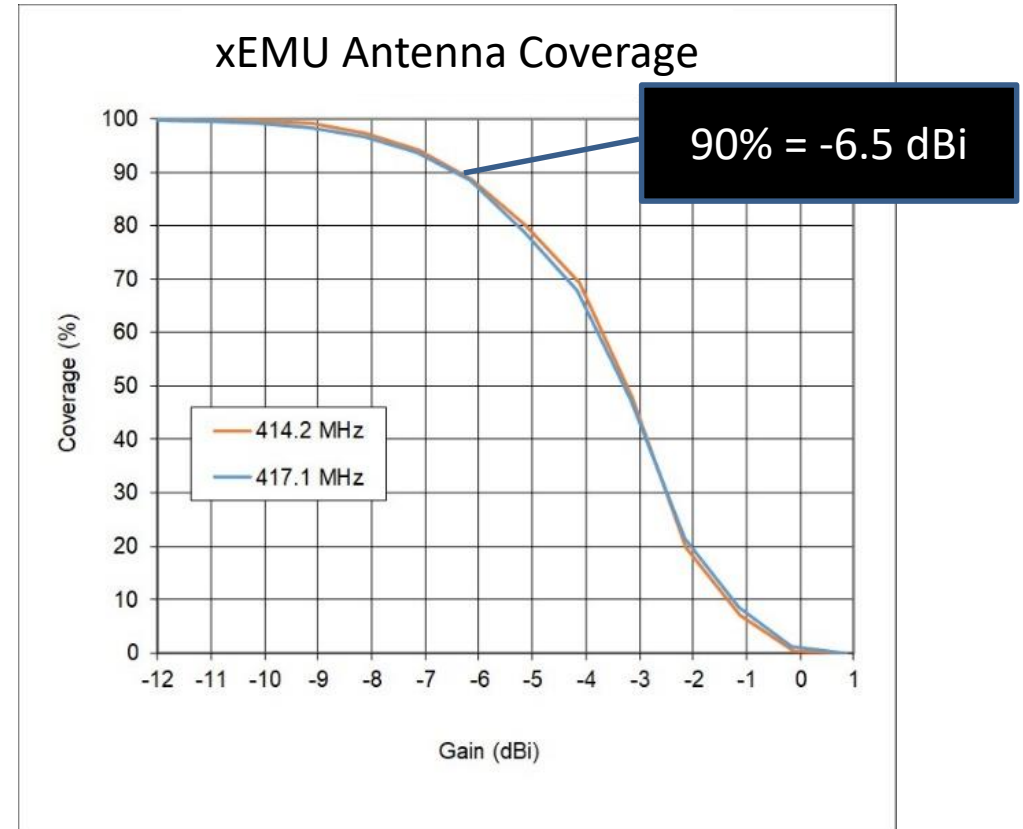



# Remaining Work

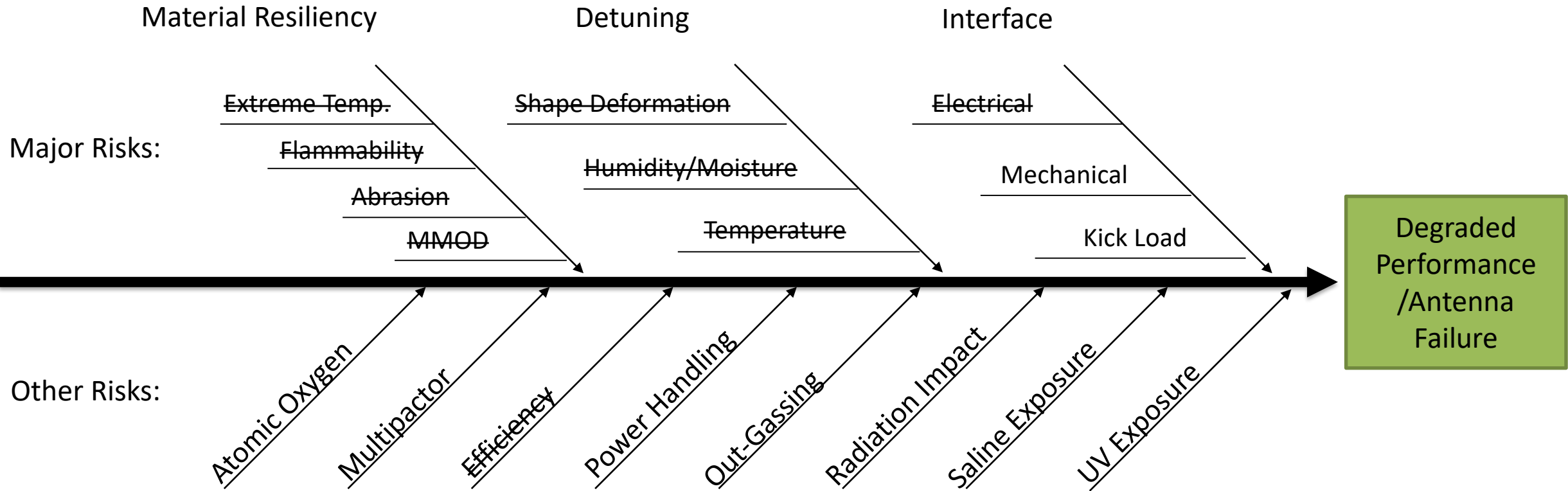



# Forward Work

- Redesign connector interface to using MIL-DTL-38999 standard connectors
- Antenna integration into the Environmental Protection Garment(EPG) and Portable Life Support System
- Design Verification Test Unit (DVTU), qualification unit, and flight unit environmental testing
- Lunar surface extensibility
  - Higher temperature extremes
  - Material degradation
  - Dust mitigation
  - Longer communication range



# Textile Antenna for Passive Sensing Application

fixed  
interrogator  
(REALM-1)

mobile  
interrogator  
(REALM-2)

ultra-long  
battery life  
**wearable**  
sensor "patch"  
(CO<sub>2</sub>, CO, CH<sub>4</sub>,  
hydrazine, etc.)

**wall-mounted**  
("peel-and-stick")  
sensor "patch"

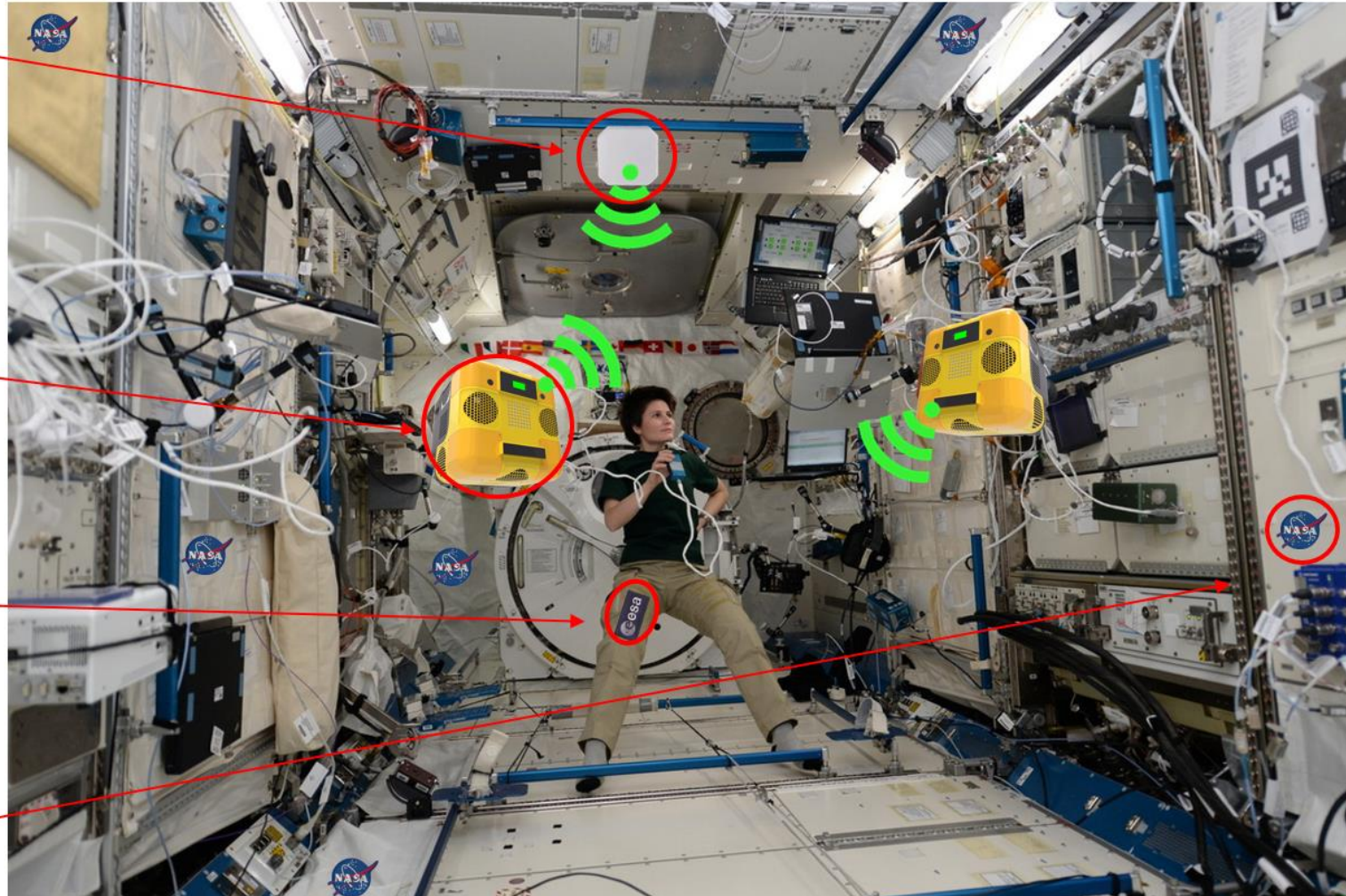



# Anechoic Chamber Tag Antenna Performance

- Laird RFID antenna is used as interrogator antenna
  - Tag antennas are placed 6 feet away from the interrogator antenna
- Textile antenna performance comparable to Alien Squiggle
  - Unlike the Squiggle, the textile antenna have minimal frequency detuning when the antenna is wore on human body



Quarterwave Patch 1  
3.5'' x 4'' x 0.375''

Receive Power (centi-dB)

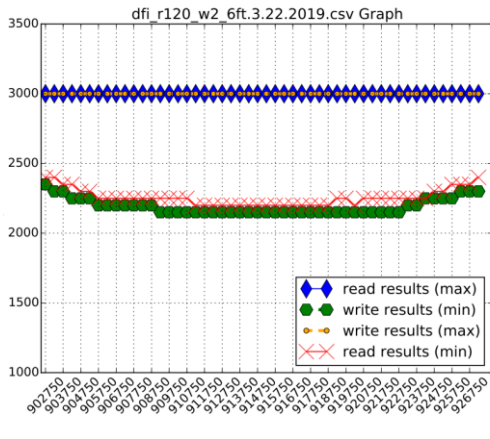

(not suitable on metal/liquid)



Alien Squiggle  
3.8'' x 0.5'' x 0.05''

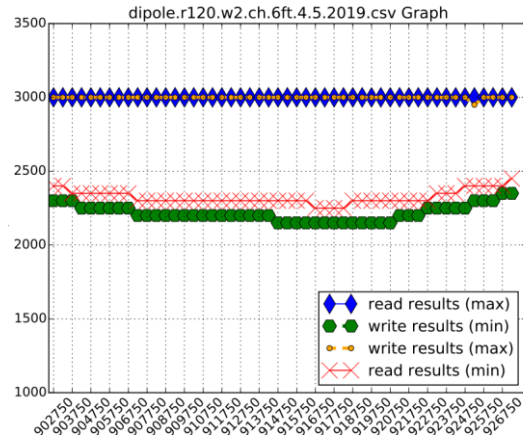

Quarterwave Patch 2  
3.5'' x 3'' x 0.125''

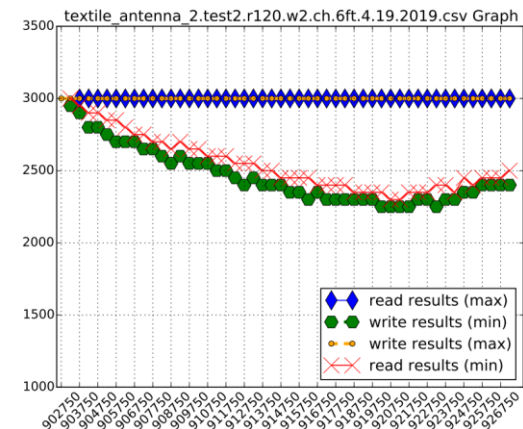

# Tests of Tags in Cylindrical Habitat (REALM Analog, JSC)

- Extreme multipath is encountered in most space vehicles
- Tests shown for (----tag under test----) lower wall only

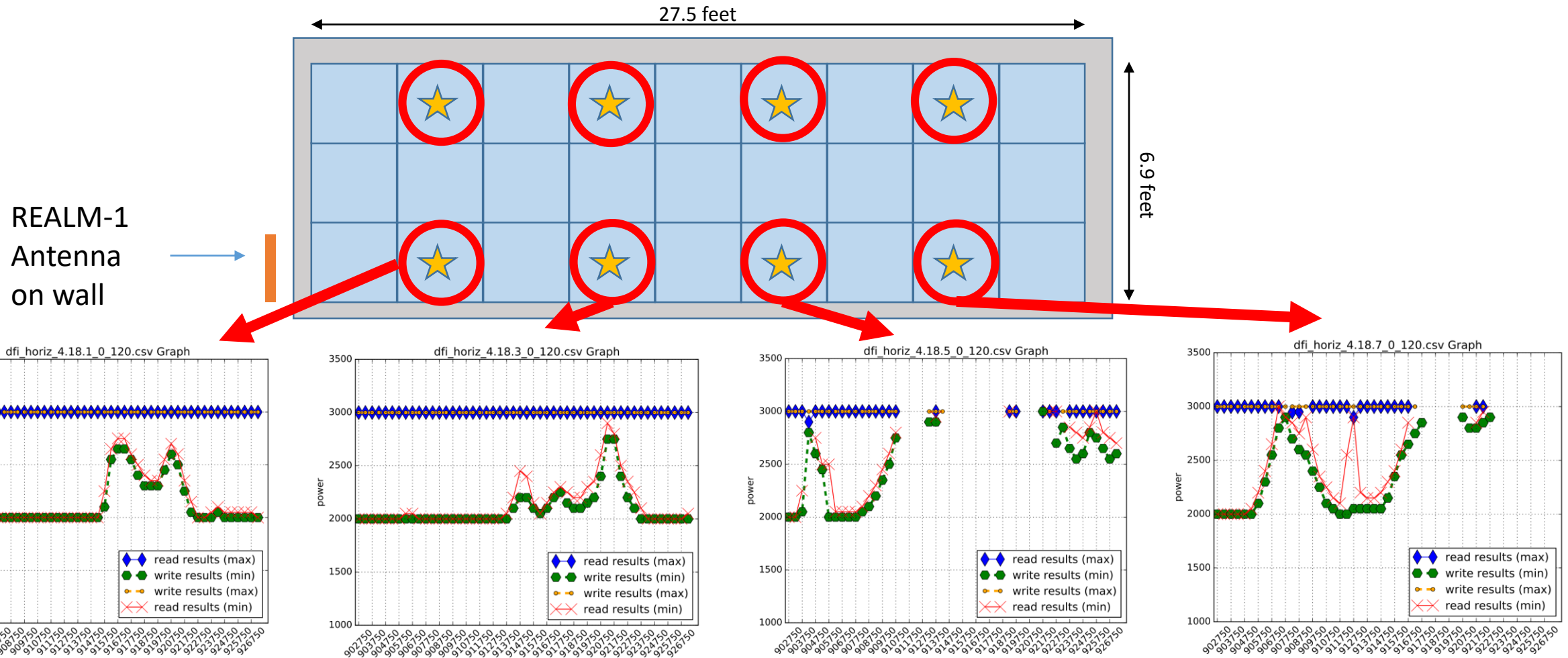

10/1/2019



# Conclusions

- Textile antenna looks highly promising for reduced mass EMU application
- Continued work required to assure reliability
- Lower mass facilitates greater redundancy through multiple units
- Integration between textile and rigid components is currently challenging
- Textile sensor antennas show promise, especially for wearable applications
- E-textiles allows antennas conformal to surfaces
  - e.g., on shoulders of EMU, on curved pressure vessels
- HF through S-band seems to be “sweet spot” for mass reduction through use of textile antennas
  - Higher frequencies are typically associated with smaller antennas (lower potential for mass reduction) and tighter fabrication tolerances difficult to achieve with textiles