

13kW ADVANCED ELECTRIC PROPULSION FLIGHT SYSTEM DEVELOPMENT AND QUALIFICATION



**Jerry Jackson, Scott Miller, Joseph Cassady
Erich Soendker, Ben Welander, Matthew Barber**
Aerojet Rocketdyne, Los Angeles, CA and Redmond, WA

Peter Peterson
NASA Glenn Research Center, Cleveland, Ohio, 44135

*Presented at the 36th International
Electric Propulsion Conference
Georgia Institute of Technology • Atlanta, Georgia • USA
October 8 – 12, 2017*

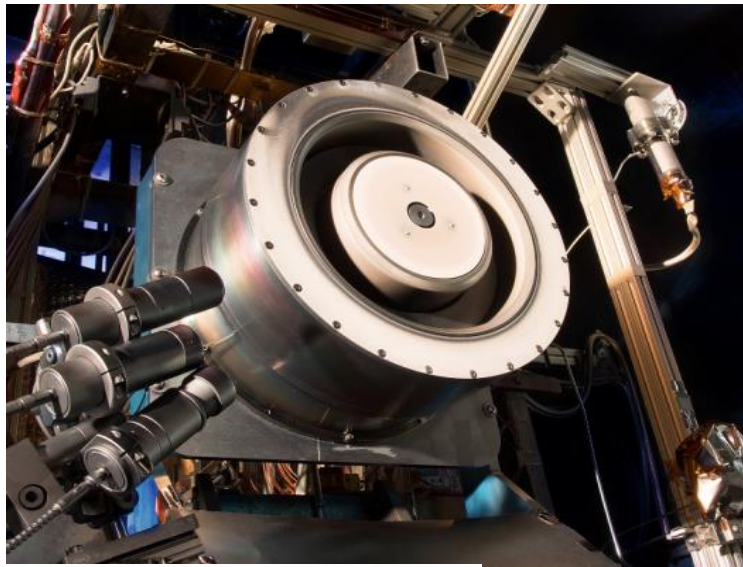

 **ZIN Technologies**

VACCO

OUTLINE



- Power and Propulsion Element
- Advanced Electric Propulsion System (AEPS) Program Summary
 - Requirements
- AEPS Component Development Progress
- AEPS Qualification
- Summary

PPE PROVIDES FOR A DEMONSTRATION OF AEPS

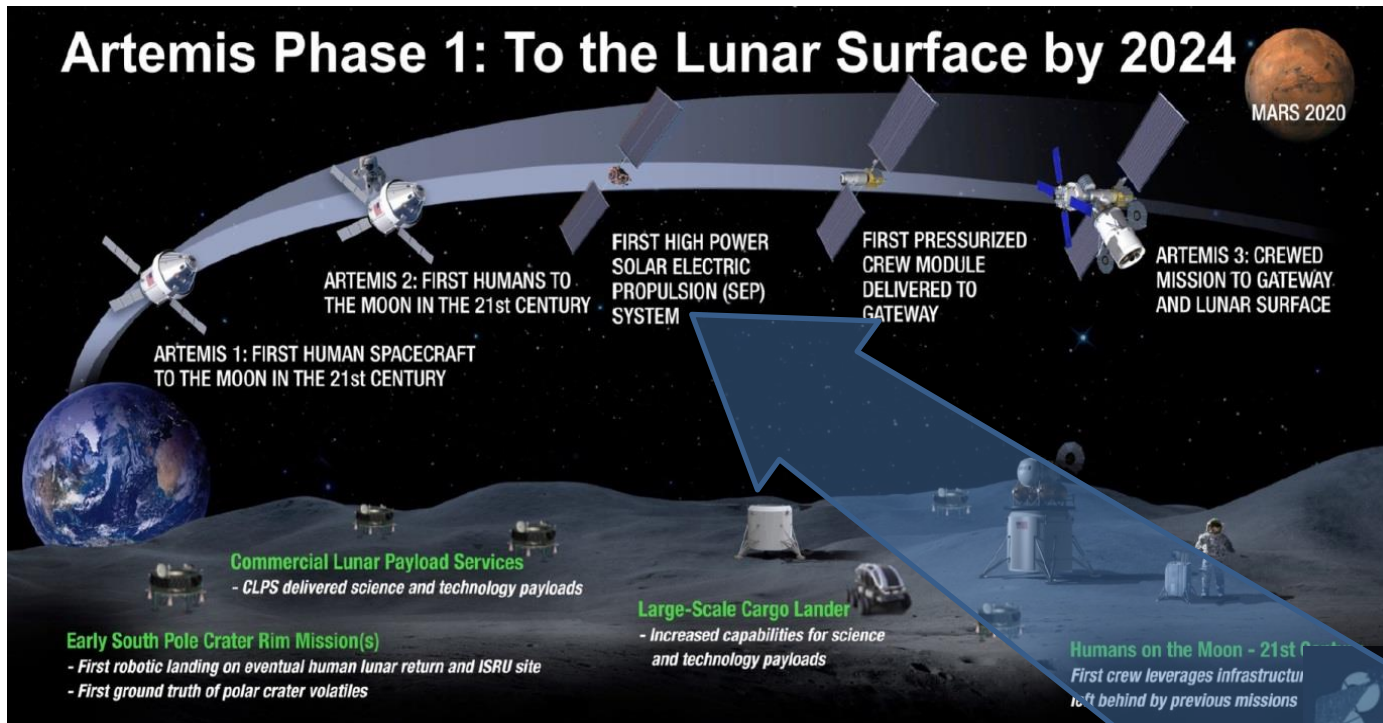

PPE is the first element of NASA's Gateway and is key to accomplishing the Artemis lunar exploration goals

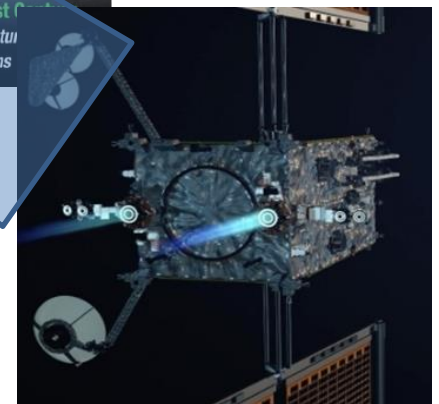

AEPS PROGRAM SUMMARY

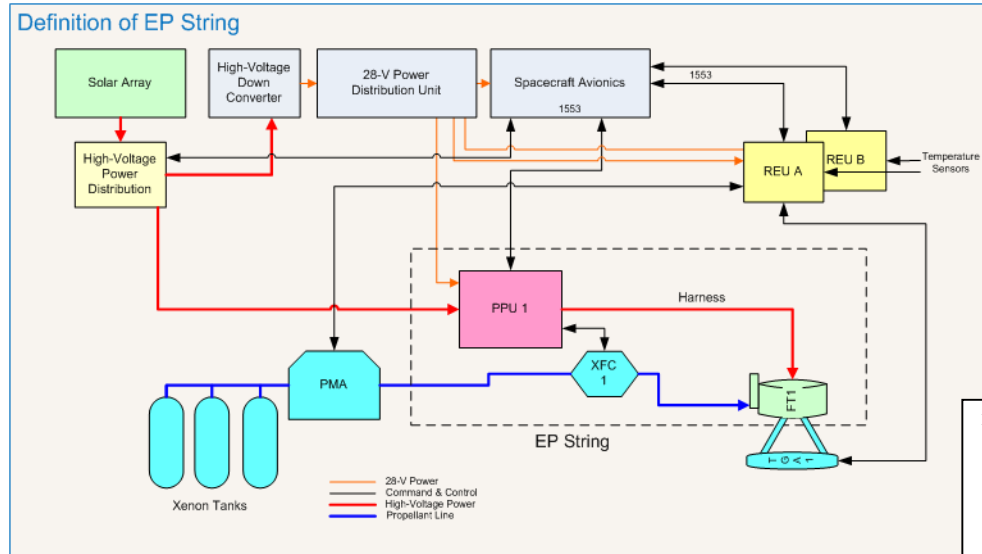

AEPS Thruster String Provides Multi-mode Operational Control

PROGRAM ELEMENTS

Current Activity

On-going development testing of the AEPS components (Thruster, PPU and XFC)

Future Activity

CDR

Qualification testing of the AEPS Components and EP String Wear testing

AEPS Goal is to Qualify a 12.5 kW Hall Thruster EP System

KEY REQUIREMENTS AND CAPABILITIES



Flexibility in Power and Discharge Voltage provide for a robust design

EP String Total Input Power	Discharge Voltage	Thrust	Specific Impulse	Total System Efficiency	System Mass [†]
13.5 kW	600 V	589 mN	2600 s	57%	123 kg †Excludes cable harnesses
11.3 kW	500 V	519 mN	2400 s	55%	
9.1 kW	400 V	462 mN	2200 s	54%	
7.0 kW	300 V	386 mN	1800 s	52%	

Performance Range Meets PPE Needs and Allows Mission Flexibility

PROGRESS ON AEPS DEVELOPMENT

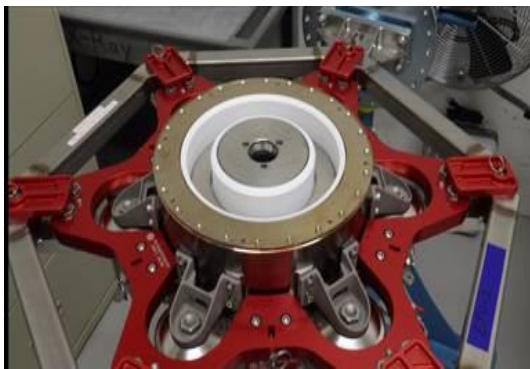

Engineering Test Unit Thruster

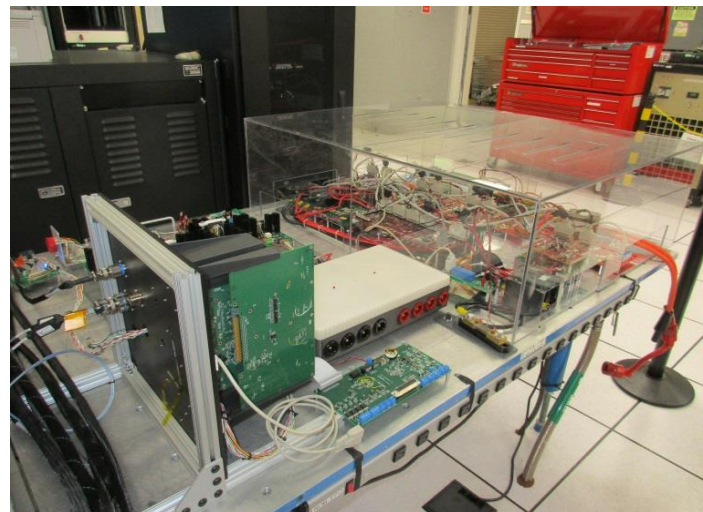
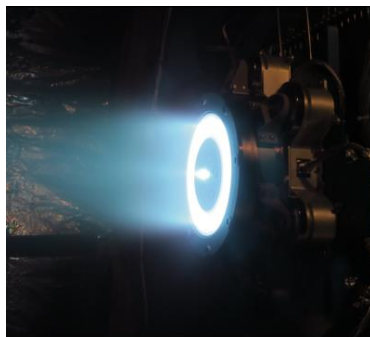

Breadboard PPU with STE

VACCO

Xenon
Flow
Controller

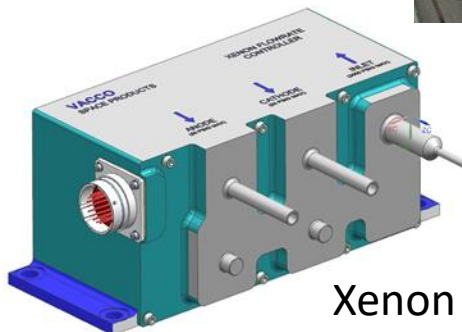
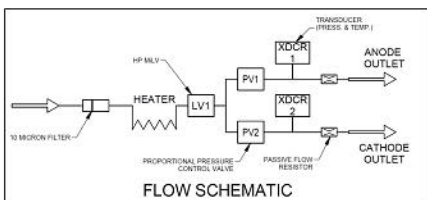

Xenon Flow Controller

Development Testing has begun on the AEPS EP String Components

AEPS QUALIFICATION TEST OBJECTIVES



Objectives

- Complete formal verification of component and system environmental and life requirements
 - PPU
 - HCT
 - XFC
 - System
- Determine if the system has any operational restrictions over life

Hardware/Process Maturity

- Flight production hardware built to formally released and configuration controlled drawings and work instructions
- Full material traceability
- Qualified processes
- Formal quality control during assembly and test

Test Scope

Environmental Testing: Qual String #1

- Flight production PPU, HCT, XFC subsystem acceptance tests
- Subsystem level qual vibe, shock
- Subsystem level TVAC/EMI/EMC
- System level hot fire test
- Thruster radiated emissions



Parallel Env &
Wear Testing
Yields Results
Prior to First
Launch

Wear Testing: Qual String #2

- Flight production PPU, HCT, XFC component acceptance test
- System level hot fire test
- System level wear test

Two Qual Units Allow Separation of Environmental and Life Testing

AEPS QUALIFICATION TEST LOGIC



Qual String #1 – Environmental

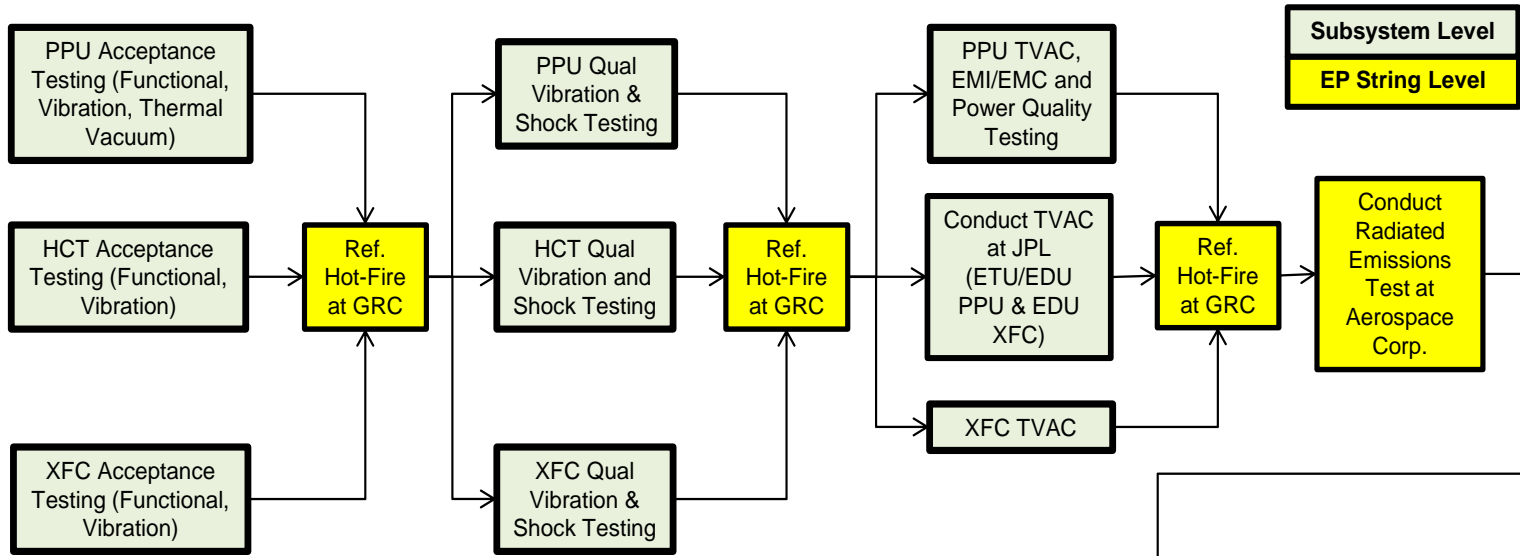

Qual String #2 – Hot Fire and Wear Testing

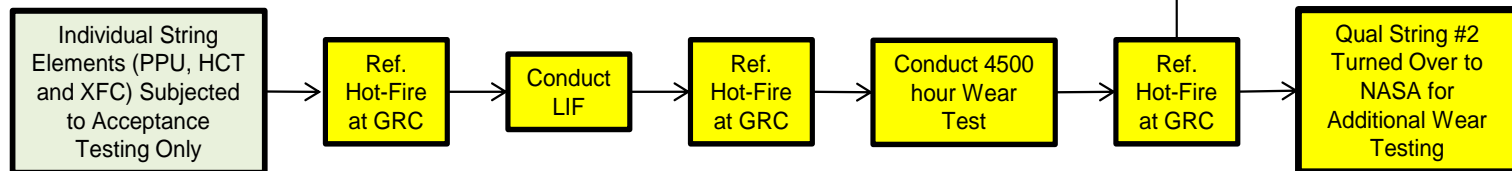

SUMMARY



- ETU hardware entering development testing
- CDR planned after development testing – Summer 2020
- Qualification testing begins in mid-2021
- AEPS slated for PPE flight in late 2022

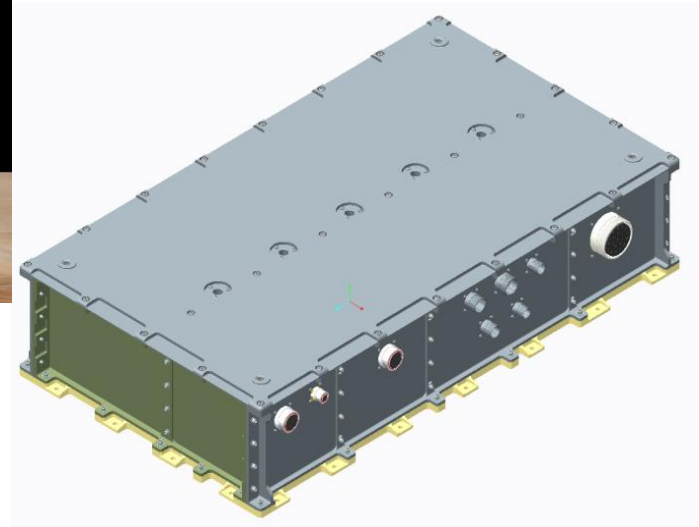
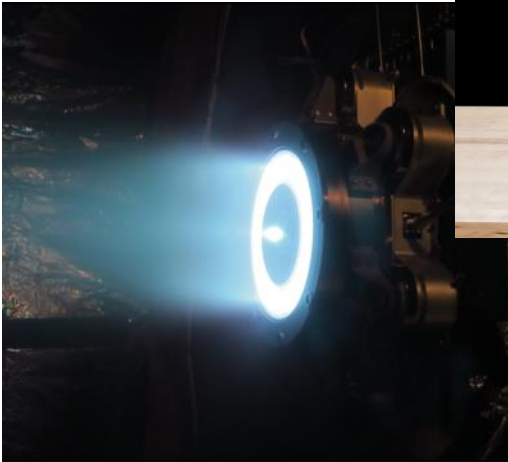

AEPS is an enabling technology for large-scale NASA & Commercial Missions

ACKNOWLEDGMENTS



The AEPS program team would like to thank the NASA Space Technology Mission Directorate for their continued support of the work discussed in this paper and all the AEPS reviewers, technical consultants and team members at Aerojet Rocketdyne and NASA who have contributed to the success of the program to date. Portions of the research described in this paper were carried out at the NASA Jet Propulsion Laboratory, under a contract with the National Aeronautics and Space Administration

