

IAC-19,D1,6,4,x52291

ASTROBEE FREE FLYERS: INTEGRATED AND TESTED. READY FOR LAUNCH!

Roberto Carlino¹, Jonathan Barlow¹, Jose Benavides², Maria Bualat², Aric Katterhagen³, Yunji Kim⁴, Ruben Garcia Ruiz⁵, Trey Smith², Andres Mora Vargas⁶

And the Astrobees Team

¹SGT/KBR, NASA Ames Research Center, USA, Roberto.carlino@nasa.gov, jonathan.s.barlow@nasa.gov.

²NASA Ames Research Center, USA, jose.v.benavides@nasa.gov, maria.bualat@nasa.gov, trey.smith@nasa.gov.

³The Bionetics Corporation, Inc, NASA Ames Research Center, USA, aric.j.katterhagen@nasa.gov.

⁴College of Software, Sungkyunkwan University (SKKU), Suwon, 440-746 Korea, oo0o8o@skku.edu.

⁵USRA, NASA Ames Research Center, USA, ruben.m.garcia.ruiz@nasa.gov.

⁶MEI, NASA Ames Research Center, USA, andres.moravargas@nasa.gov.

As of March 2019, four Astrobees free-flying robots have been integrated, tested and shipped to NASA's Johnson Space Center, Texas, ready to be launched to space.

Two of these Astrobees units (Honey and Bumble) will be launched to the International Space Station (ISS) on April 17, 2019, on the Cygnus NG-11 (Northrop Grumman) cargo resupply spacecraft from the Mid-Atlantic Regional Spaceport (MARS) launch facility, at NASA's Wallops Flight Facility, in Virginia, while the third unit (Queen) will be launched in mid-July 2019, with the cargo resupply mission Space-X 18, from Cape Canaveral, at NASA's Kennedy Space Center.

The primary purpose of the Astrobees system is to provide an autonomous and flexible platform for research on zero-g free-flying robotics, with the ability to accommodate guest researchers looking to utilize the unique capabilities of this platform in the microgravity of low earth orbit, and to advance the state of the art of guest science software and research payloads, which range from gecko-inspired adhesives for perching on smooth surfaces, to augmented reality interfaces to help astronauts and robots work together effectively, to RFID reader, performing inventory of RFID tagged items inside the ISS.

Astrobees will also serve utility functions, such as free-flying cameras to record video and provide assistance during astronaut activities, and as mobile sensor platforms to conduct surveys of the ISS.

In this paper we will give an overview of the status of the Astrobees system, which includes the docking station already launched and mounted in the JAXA JEM module of the ISS, the Astrobees robots, the Astrobees robotic arms, the ground data system (GDS) and the development of the several guest science payloads.

I. INTRODUCTION

In this paper we will describe the Astrobees research platform, divided in its four main elements; the three free-flying robots, the Docking station, the Ground Data System, and the Perching Arm.

An update on the status of the project and its systems, now launched to the ISS, will be given. Some of the future guest science payloads in development, and some of the lessons we learned during the realization of the project will also be reported.

The Astrobees free flyers will be working throughout the International Space Station (ISS) together with the astronauts, allowing research opportunities for scientists and researchers, and saving astronaut time by performing routine tasks. Astrobees will replace the Synchronize, Position, Hold, Reorient, Experimental Satellites (SPHERES), current free flyers on the ISS, and one of the most used payload facilities [Mohan et al., 2009]. Like SPHERES, Astrobees's primary goal is

to support guest science experiments, but it will be significantly more capable than SPHERES.

Fully autonomous and battery-powered, each one-foot cube is packed with sensors that will open up new areas of research. Guest scientists will have a microgravity research facility to test new ideas, and it will give ground control better situational awareness of the ISS, for example by monitoring radiation and air quality that will keep astronauts safe. [M. Bualat et al., 2018]

Astrobees was designed from the beginning to operate safely without astronaut supervision, incorporating safety controls such as collision mitigation and use of non-flammable materials. By using a vision-based navigation system, Astrobees does not require installing any new infrastructure in the ISS interior, enabling it to operate throughout the U.S. Orbital Segment of the ISS.

Astrobee will have a built-in robotic arm that occupies the top payload bay, but it can also be swapped with a guest scientist payload. The free flyers move around the ISS using 2 electric impellers, but as there is no gravity in space they are not limited by the lifting power.

Astrobee will also continue the Zero Robotics competition, started with SPHERES, giving the opportunity to high school and middle school students from different countries to develop code that will control the free flyers fly on the ISS. All three Astrobee free flyers have now launched to the ISS and are ready to go through on-orbit commissioning activities.

II. ASTROBEE SYSTEMS

The Astrobee research platform is mainly composed of 4 different systems:

1. Astrobee Free flyers
2. Dock Station
3. Ground Data System (GDS)
4. Perching Arm

Here we will describe each system in brief detail. Additional detail will be forthcoming in a more extended article focusing on Astrobee design.

II.I *Astrobee free flyers*

From a high-level perspective, the Astrobee free flyers can be described by three main sections: two propulsion modules located on the sides and one central module, containing all the processors and sensors, located in the center (Fig. 1).

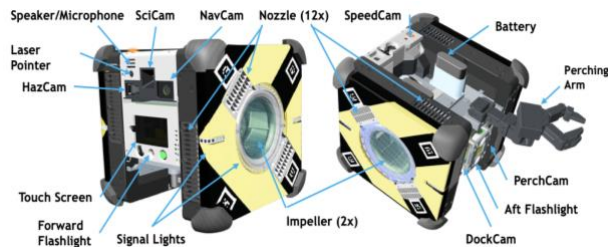

Fig. 1: Overview of Astrobee components.

Each of the two interchangeable propulsion modules have a plenum, pressurized by a single centrifugal impeller. The impeller pulls in air through a central intake and feeds six exhaust nozzles around the sides of the module. In order to cancel unwanted drag torque and gyroscopic moment disturbances, the two propulsion modules rotate in opposite directions and at the same speed.

Astrobee's central module has three main onboard processors: The Low-Level Processor (LLP), Mid-Level Processor (MLP), and the High-Level Processor (HLP).

These processors are Commercial Off-The-Shelf (COTS) devices based on ARM architecture in a

System-On-Module (SOM) format. The LLP is in charge of the propulsion system, and reliably runs the high-rate control software. The MLP software includes the compute-intensive machine vision and path planning algorithms. The HLP hosts guest science software as Android PacKages (APKs) and is also in charge of streaming HD video compression and touchscreen interaction. The LLP, MLP, and HLP communicate with each other and with the Dock station via Ethernet connection.

The Astrobee Robot Software (ARS) runs on the HLP, MLP, LLP, and Dock's processor. It is modular and distributed. It uses a service-oriented robotic architecture style and makes use of the Robot Operating System (ROS). The LLP and MLP run Ubuntu Linux 16.04, and the HLP runs Android (Nougat 7.1).

Each Astrobee uses six COTS external cameras (also shown in Figure 1):

1. NavCam – RGB camera for mapping and localization
2. DockCam – RGB camera for docking maneuvers.
3. PerchCam – LIDAR for perching operations
4. SciCam – RGB camera for HD videos and operators awareness
5. HazCam – LIDAR for obstacle detection.
6. SpeedCam – Greyscale, Rangefinder and Accelerometer for redundant velocity estimates.

Three of the six cameras point forward (NavCam, HazCam and SciCam), two point aft (DockCam and PerchCam) and one points up (SpeedCam).

In addition to the cameras, each Astrobee carries a 6-axis inertial measurement unit (IMU) mounted near its geometric center.

Astrobee is able to navigate inside the ISS thanks to its on-board mapping and localization algorithms.

Mapping is based on a sparse mapping pipeline, which localizes via detection and matching of visual features based on a tree database. More of these details are discussed in [P. Kim et al., 2017] and [B. Coltin et al., 2016].

Astrobee's navigation and control tasks are allocated between the MLP and LLP. The MLP hosts the navigation part of the software as ROS nodes, handling trajectory generation and modification, as well as vision-based tasks such as localization. The LLP hosts the Extended Kalman Filter (EKF) used for state estimation and the controller that calculates force and torque commands used to produce PWM outputs for each servo on the propulsion modules.

From a high-level perspective, Astrobee has an internal and an external type of communication. Internal communications are based on the ROS communication framework, e.g. messages (data distribution), services (simple instantaneous requests), and actions (complex longer requests).

External communications between Astrobees on the ISS and the Ground Control Center or other Astrobes make use of NASA's Robot API Delegate (RAPID) and the Data Distribution Service (DDS) middleware. Astrobees use DDS protocol to communicate commands, telemetry, and video through the ISS data network and the Ku-band satellite downlink.

II.II Dock Station

The Astrobees Dock station is a recharging and high-speed communication station, currently placed in the Japanese Kibo module of the ISS (Figure 2).

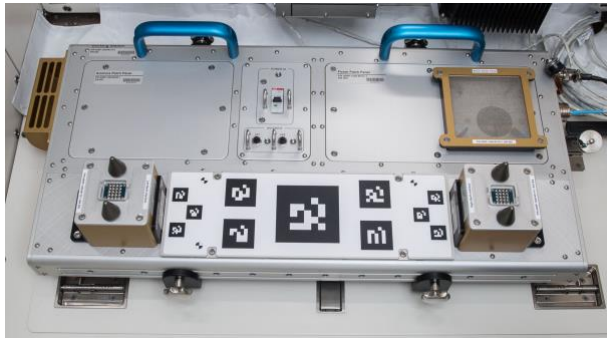

Fig. 2: Astrobees Dock Station installed in the Kibo module of the ISS.

It has two separate berths to which two Astrobes can be left attached at the same time and in a hibernate mode, the third Astrobee may be stored and powered off in a storage module.

The Dock berth interface to Astrobees enables docking with up to one centimeter error tolerance. Four magnets located to the corners of the interface hold Astrobees attached, and can be released further into the berth allowing undocking of Astrobees, the magnets automatically extend back again after a few seconds. The Dock Station has some AR target fiducials that are in view of the DockCam during docking approach, enabling more precise and robust localization.

Currently, the Dock is installed near the port-end of the Japanese Kibo module of the ISS. This location was selected to minimize interruption of astronaut activities; it is a low-traffic area near a dead-end and far from the docking ports that are used for visiting cargo vehicles.

In case the Dock needs to be moved later, its design includes several options for astronaut reconfiguration. Also, the berth posts can be tilted up or down in case the Dock is mounted in a confined space, allowing Astrobees to approach the Dock with a different path, avoiding possible close obstacles.

II.III Ground Data System (GDS)

The Astrobees Ground Data System (or also called the Astrobees Workbench) includes the Control Station,

a graphical application that monitors and controls the Astrobees free flyers, and ground servers that relay and archive data collected during on-orbit activities.

There are two types of the Control Station. The Engineering Control Station, which has the ability to send commands and view telemetry, and the Crew Control Station, designed to be used when a guest science experiment needs to be operated locally by an astronaut with minimum training.

GDS is based on Eclipse 4 Rich Client Platform (RCP), derived from the Visual Environment for Robot Virtual Exploration (VERVE) code base, which has been used in the past for space-analog testing with various robots [Lee et al., 2013]. It was also the basis of the Smart SPHERES Workbench previously used to control the SPHERES free flyers inside the ISS [Fong et al., 2013]. The Control Station has been ported to run both on Ubuntu Linux (mostly used internally by developers) and Windows (supported release for external users). The Control Station has several tabs, each of which displays a different set of controls. The Crew Control Station has four tabs (Overview, Run Plan, Teleoperate, and Guest Science), and the Engineering Control Station includes additional six tabs. Most tabs connect to one Astrobee at a time, except for the Overview tab and the Guest Science tabs, which can monitor and control up to all three Astrobes at the same time.

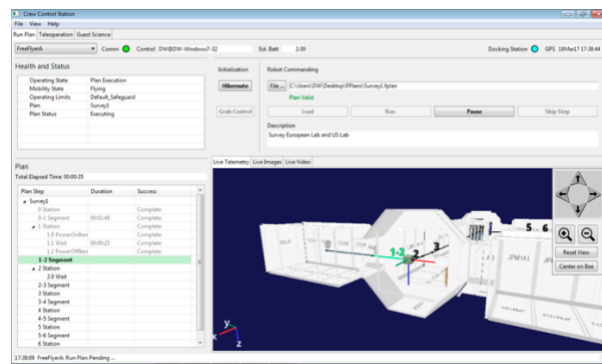

Fig. 3: Astrobees Ground Data System software

II.IV Perching Arm

Each Astrobee can carry an arm in its top aft payload bay (Fig. 4) [Park et al., 2017]. The arm's primary function is to enable autonomous perching onto ISS handrails. While perched, the arm acts as a pan/tilt unit for forward-facing cameras (like the SciCam). Perching onto handrails will also reduce the power consumption and interference with ISS operations.

Another function is to allow future guest science research on robotic manipulation. Each arm has three degrees of freedom: two for the arm pitch joints, and one for the gripper.

The arm length and joint arrangement are designed to maximize the range of pan/tilt motion when Astrobees is grasping a handrail, while also allowing the arm to stow fully inside the top aft payload bay, within the volume protected by the bumpers (Fig.4).

The gripper is sized for grasping a handrail, but the geometry is also optimized to successfully grasp a wide variety of object shapes [Ciocarlie et al., 2014].

The autonomous perching scenario consists of the following steps. First, the Astrobees navigates to a pre-selected perching approach point using general navigation. Once there it starts station keeping. Afterwards, it may switch to perching navigation mode. It can now deploy the arm and open the gripper. Astrobees will then fly straight toward the handrail until the gripper palm makes contact. The gripper now closes, and a test of the grasp is performed, by verifying that Astrobees does not move when propulsion thrust is applied. At this point, propulsion finally turns off.

In perching navigation mode, the Astrobees's position estimator uses the DepthMap localizer, which provides updates on the Astrobees's position relative to the handrail by extracting the geometry of the handrail and wall from 3D point clouds produced by the PerchCam [Lee et al., 2018]. The PerchCam position is optimized relative to the arm so that it has continuous viewing of the handrail throughout the perching phase. If needed for guest science, an astronaut can swap out the gripper module on-orbit.

The three arms launched to the ISS with SpaceX 18 cargo resupply mission in July 2019. Future guest scientists could also mount two perching arms in the top and bottom payload bays of a single Astrobees.



Fig. 4: Astrobees's Perching Arm in phase of deployment, mounted in the top payload bay.

III. GUEST SCIENCE PAYLOADS

Within the context of the Astrobees research platform, Guest Science is the work Guest Scientists do

using the Astrobees platform, which may involve a combination of hardware and software.

In [Mora et al., 2018], the Guest Science Program describes how Guest Scientists can develop Guest Science software for Astrobees.

III.I REALM

NASA's Johnson Space Center (JSC) REALM team is developing the Recon activity: a Radio Frequency Identification (RFID) reader payload to be installed in Astrobees's bottom forward payload bay. It aims to expand RFID coverage area and refine Astrobees localization estimates [SAWG0719, 2019]. The Astrobees Facility has supported REALM in various fronts: integration and testing at Ames Research Center's Granite Laboratory as well as Electromagnetic Interference (EMI) tests at JSC. It has also supported the development of a set of Astrobees "skins" incorporating RFID antennas which connect to REALM's payload, as shown in Fig. 5.

The REALM team has developed their own control center at JSC, which includes also a 3D operator interface focused on their payload that listen to the same telemetry as the baseline control station. Additionally, REALM can be operated in a variety of modes, e.g. RFID surveys and homing search.

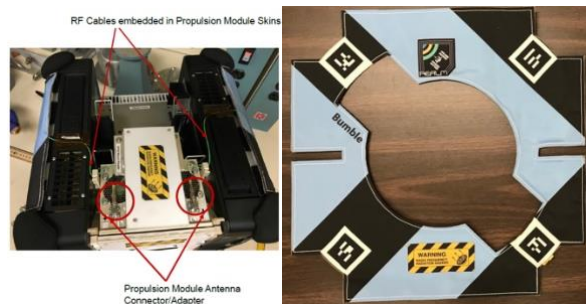

Fig. 5: REALM's Guest Science Payload. On the left, the integrated payload with Astrobees. On the right, REALM's customized Astrobees skin-antenna.

III.II SoundSee

Astrobotic and Bosch worked in the development of SoundSee, a payload targeting deep audio analytics for ISS operations. SoundSee will work with Astrobees on assessing noise levels and monitoring equipment health. SoundSee plans to accomplish this through the generation of spatiotemporal mapping of the ISS acoustic environment. The Astrobees Facility team has supported the development of tests at ARC and JSC. Similar to REALM, SoundSee experienced exceedances during EMI testing. These issues were solved by revising avionics and shielding of the payload walls as seen in Fig. 6. All the walls were covered in copper-

based adhesive substantially reducing its electromagnetic emissions.

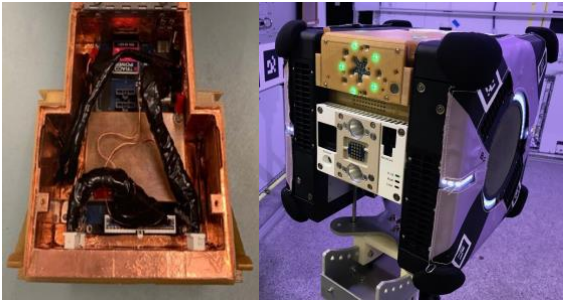

Fig. 6: SoundSee payload. On the left, SoundSee avionics shielding. On the right, SoundSee integration test at NASA ARC.

III.III Gecko

Stanford's Autonomous Systems Laboratory (ASL) has developed a flat-surface gecko-inspired adhesive gripper that can be integrated with Astrobee to test it on the ISS. ASL aims to demonstrate the capabilities of the gripper for manual and autonomous perching of the robot onto ISS walls and other flat surfaces. The Astrobee Facility has supported the software development and hardware integration and testing of the Gecko gripper, as well as their EMI testing at JSC and verification testing at ARC's Granite Lab. Gecko was launched on SpaceX-18 in July, 2019 and are waiting for on board checkout and operations.

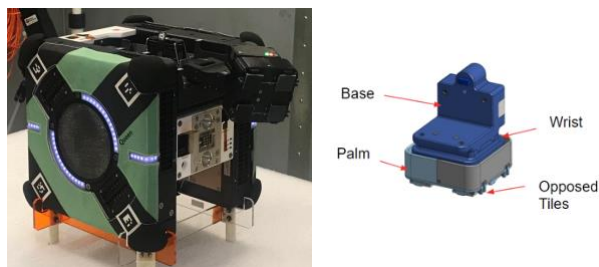

Fig. 7: Gecko gripper integrated with Astrobee (left), Gecko gripper overview (right).

III.IV RINGS

Florida Institute of Technology leads the RINGS project, aiming to demonstrate vision-based navigation for formation flight of free flyers on the ISS, using electromagnetic propulsion. RINGS is at an early stage of development where it has demonstrated autonomous alignment of two different free flyers.

A 3D view of the RINGS is shown in Fig. 8.

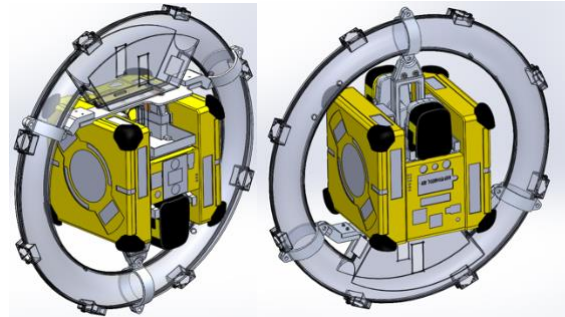

Fig. 8: Rendering of RINGS, attached to Astrobee on top view (left) and bottom view (right).

III.V Astrobotics

NPS aims to demonstrate that free flyers like Astrobee can perform manipulator based hopping maneuvers or "Astrobotics". This maneuver developed at NPS has already demonstrated initial hopping with its own manipulator arm. The Astrobee Facility has provided guidance on software development and further its support by providing the necessary avionics NPS will require to replicate Astrobee's perching arm. This tool will considerably accelerate NPS development and testing process.

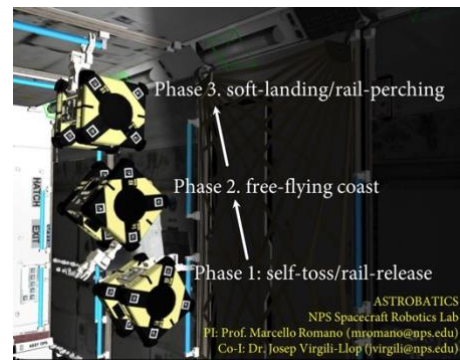

Fig. 9: Astrobee free flyer executing the three phases of a hopping manoeuvre on the ISS.

III.VI JAXA

The JEM Internal Ball Camera or Int-Ball is an experimental, autonomous, self-propelled, and maneuverable ball camera in the Japanese Kibo module of the ISS. It has been developed and deployed by JAXA since 2016 [Tanishima et al., 2018]. Since 2017, NASA ARC has been collaborating with JAXA's Int-Ball team to create a heterogeneous team of free-flying robotic activities using Int-Ball and Astrobee. The Int-Ball team has been introduced to the Astrobee Robot Software and has already run experiments using their developed HLP applications at ARC's Granite Lab.

III.VII Port Tester

The Astrobee Facility team has developed and deployed the Port Tester as part of the team's effort to further (1) facilitate the Guest Science development life cycle [Mora et. al, 2018], (2) provide a means to access Astrobee internal serial ports, (3) enable diagnosing and evaluating Astrobee expansion port functionality and (4) provide external USB access to future Guest Scientists. PortTester is shown in Fig. 10.

The Astrobee Facility team has developed an HLP Guest Science application and an MLP tool to interact with the Port Tester internal computer (Raspberry Pi Zero) and the external USB port through serial communication. In addition, the Port Tester is capable of measuring the electrical current at each payload bay by requesting up to 2.0 A from Astrobee. The Port tester is also used to monitor other electrical parameters like voltage, power and temperature.



Fig. 10: Port Tester flight unit 2 at NASA ARC.

IV. CONCEPT OF OPERATIONS

In preparation for Guest Science, the Astrobee Facility must first test and certify that the Astrobee hardware is functioning properly on the ISS and ready for future payload and software integration from guest researchers. The first critical step to introducing the Astrobee Facility to the ISS was the installation and checkout of the Astrobee Dock. The Astrobee Docking Station (measuring approximately 85 cm x 38 cm x 28 cm, not including mounting bracketry) has two berths, each providing an Ethernet interface and power to an Astrobee robot. Unless other ISS operations require the Astrobees to be stowed, the Free Flyers can remain deployed and docked, ready for operations on short notice pending required software updates. The Dock was successfully installed February 15, 2019.

Following the Dock installation, commissioning of the Free Flyers began. To commission each of the three Free Flyer Robots, mapping, calibration, localization, and mobility capabilities must be validated. To date, the first Astrobee unit, Bumble, is one step from completing its commissioning. The following table documents

completed commissioning sessions (black), and planned sessions (blue) for the calendar year. The Payload Installation and Payload Demonstration Activities will focus on installing and demonstrating functionality of all three Astrobee Perching Arms that arrived at the ISS on SpaceX-18 July 2019. Following the commissioning of two of the three Astrobee Free Flyers, the Astrobee Facility team plans to begin running Guest Science. The dates of remaining Commissioning Activities will be determined by ISS Crew Time. Although Astrobee is intended to be autonomous from crew time in the future, crew is required during the Commissioning Activities.

Activity	Robot	Date
Astrobee Checkout	Bumble	4/30/2019
Mapping/Calibration	Bumble	5/13/2019
Mapping 2	Bumble	5/23/2019
Localization/Mobility 1	Bumble	6/14/2019
Localization/Mobility 2	Bumble	7/12/2019
Localization/Mobility 3	Bumble	7/24/2019
Localization/Mobility 3b	Bumble	8/28/2019
Astrobee Checkout/Calibration	Honey	2019 TBD
Localization/Mobility 4	Bumble	2019 TBD
Ops Demo	Bumble/Honey	2019 TBD
Localization/Mobility 1	Honey	2019 TBD
Payload Installation	Bumble/Honey	2019 TBD
Payload Demo	Bumble/Honey	2019 TBD
SPHERES/Astrobee Hand-off	Bumble/Honey	2019 TBD

Table 1: List of Astrobee's on-orbit activities in 2019.

During the commissioning phase, many lessons have been learned that will help the Astrobee Team efficiently guide Guest Scientists. Lesson learned in performing commanding, preparing crew procedures and other planning products, troubleshooting network issues, and critical lessons involving imagery considerations will be critical in optimizing guest science. Astrobee's capacity to operate as a mobile camera platform introduces new and exciting capabilities that also come with challenges. The Astrobee Operations and Engineering teams will help Guest Scientists navigate these challenges to better enhance science.

In addition to assisting in the preparation of necessary flight products (crew procedures, planning products, etc.), the Astrobee Operations Team will also help Guest Scientists in real-time operations of their

science. Details of these operations will be outlined and are unique to each Guest Science Team. Regarding controlling the Free Flyers, each Astrobee accepts commands from only one Control Station at a time. However, additional Control Stations may monitor telemetry from multiple Astrobees and take control of them if necessary. This capability promotes safety if multiple Astrobee activities are occurring simultaneously. For example, a guest scientist may use one Control Station to conduct a payload experiment with one Astrobee, while a flight controller uses another Control Station to command a different Astrobee to search for a tool. Both the guest scientist and the flight controller can observe the motions of the other free flyer, in addition to their own free flyer, and watch for interference.



Fig. 11: Checkout activity with Astronaut Anne McClain

V. LESSONS LEARNED

A list of important lessons we learned after the completion of Astrobee and Guest Science Payloads is presented in this section.

ElectroMagnetic Interference (EMI) testing at NASA's Johnson Space Center on some Guest Science Payloads detected some exceedances, which caused a late redesign of the avionics and required additional shielding of the payloads to comply with the acceptable ISS operational levels. We learned that EMI tests of early Guest Science prototypes could have been able to avoid that.

During the development of Astrobee, we realized that complex features or systems can have an important impact on the total lifecycle of the project. The addition of nice-to-have components on Astrobee (e.g. flashlights, laser pointer, microphone) should have not been included in the baseline Astrobee hardware, and maybe being added as future payloads.

Performing plenty risk reductions tests as early as possible is something else we learned during the integration and testing of Astrobee. For example, we found a design flaw that caused one of Astrobee's

processors to be damaged during a vibration test. A better definition of the test objectives might have helped to find this flaw earlier in the development, causing less delay and redesign of some of the components.

The use of 3D printing components was very useful for some reasons, but we also learned that it is important to incorporate increased tolerances due to 3D printing variability and complement with post-print machining when tighter tolerances are needed.

Using Commercial Off-The-Shelf components (COTS) was definitely a good advantage for the development of Astrobee. However, as the development of spaceflight projects is usually much longer than that for consumer electronics devices, some of the COTS Astrobee was supposed to integrate in its design, became unavailable before all the necessary parts were shipped. That caused some rework and redesign to integrate the new alternative part.

VI. FUTURE WORK

After the success of SPHERES being operated on the ISS for 13 years, we also look forward to the success of Astrobee during its operation on the ISS. Intra-vehicular robotics (IVR) will play a key role in the future missions of NASA's Exploration program. The future Lunar Gateway is expected to be attended by astronauts for only 10-15% of the time [Crusan et al., 2018]. NASA projects such as Integrated System for Autonomous and Adaptive Caretaking (ISAAC) [NASA ISAAC] are studying possible robotic caretaking use cases during uncrewed periods, including fault recovery, transferring cargo around the Gateway, and others.

Astrobee is expected to complete the commissioning phase of two of the three free flyers by December 2019. Afterwards, two or more guest science payloads should be ready on the ISS to be used for their experiments. There is definitely a lot on Astrobee's plate for the years to come. As of September 2019, more than 40 projects that have expressed interest in using Astrobee.

Multi-robot student competitions with JAXA's Int-ball free flyer are currently under discussion. Sensor survey applications, automating repetitive tasks like collecting video surveys of the ISS interior sensors already being developed for ISS use, including acoustic noise, CO₂ concentration, radiation, and WiFi signal strength [Bualat et al., 2018].

To support future multi-robot operations, there is an existing effort to implement robot-to-robot communication using DDS just like ground-to-robot communication is currently performed. This implementation is called Astrobee-Astrobee bridge. It is based on a modified DDS-ROS bridge connecting a free flyer with GDS. This communication is vital to avoid collisions between robots and their environment. Each

robot publishes its own EKF topic and subscribes to other robots to obtain their pose and location. This process is currently being implemented only in simulation and we aim to publicly release it as part of the Astrobeer Robot Software (ARS) [Github, 2019]. A screen capture from this implementation is shown in Fig. 12.

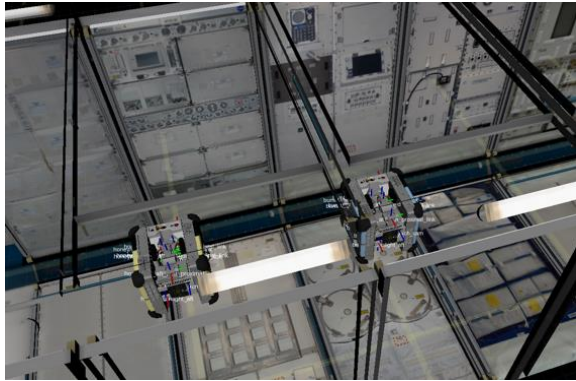

Fig. 12: Two Astrobeer robots moving together inside the ARS simulated ISS.

We expect that 2020 will be a crucial year for Astrobeer, proving its great potential for radically maturing Intra-Vehicular Robotic (IVR) technology and utilization on future NASA spacecraft.

ACKNOWLEDGMENTS

We would like to thank the ISS Research Integration Office, all the Guest Scientists, the NASA Advanced Exploration Systems program, and the ISS SPHERES team for their collaboration. The NASA Game Changing Development Program (Space Technology Mission Directorate), ISS SPHERES Facility and Astrobeer Facility (both funded by NASA's Advanced Exploration Systems) and the Intelligent Robotics Group (IRG) at NASA Ames Research Center, Moffett Field. This paper would not be possible without your outstanding work.

VII. REFERENCES

[Mohan et al., 2009]. Mohan S, Saenz-Otero A, Nolet S, Miller DW, Sell S. SPHERES Flight Operations Testing and Execution. 58th International Astronautical Congress, Hyderabad, India. 2007 IAC-07-A2.6.03DOI: [10.1016/j.actaastro.2009.03.039](https://doi.org/10.1016/j.actaastro.2009.03.039).

Also Mohan, Swati, Alvar Saenz-Otero, Simon Nolet, David W. Miller, and Steven Sell, 'SPHERES Flight Operations Testing and Execution', Acta Astronautica, 65 (2009), 1121–32 <http://dx.doi.org/10.1016/j.actaastro.2009.03.039>. DOI: [10.1016/j.actaastro.2009.03.039](https://doi.org/10.1016/j.actaastro.2009.03.039)

[M. Bualat et al., 2018] M. Bualat, T. Smith, T. Fong, "Astrobeer: A New Tool for ISS Operations" in *International Conference on Space Operations*, Marseille, France, 2018.

[P. Kim et al., 2017] P. Kim, B. Coltin, O. Alexandrov and H. J. Kim, "Robot Visual Localization in Changing Lighting Conditions," in *IEEE International Conference on Robotics and Automation (ICRA)*, 2017.

[B. Coltin et al., 2016] B. Coltin, J. Fusco, Z. Moratto, O. Alexandrov and R. Nakamura, "Localization from visual landmarks on a free-flying robot," in *IEEE/RSJ International Conference on Intelligent Robots and Systems (IROS)*, Daejeon, Korea, 2016.

[Park et al., 2017] Park, I.-W., Smith, T., Wong, S. W., Piacenza, P., and Ciocarlie, M. (2017). Developing a 3-DOF compliant perching arm for a free-flying robot on the International Space Station. In Proc. IEEE Int. Conf. Adv. Int. Mech. (AIM).

[Lee et al., 2013] Lee, S. Y., Lees, D., Cohen, T., Allan, M., Deans, M., Morse, T., Park, E., and Smith, T. (2013). Reusable science tools for analog exploration missions: xGDS web tools, VERVE, and Gigapan Voyage. Acta Astronaut., 90(2):268–288.

[Fong et al., 2013] Fong, T., Micire, M., Morse, T., Park, E., Provencher, C., To, V., and Wheeler, D. (2013). Smart SPHERES: A telerobotic freeflyer for intravehicular activities in space. In Proc. AIAA Space.

[Ciocarlie et al., 2014] Ciocarlie, M., Hicks, F. M., Holmberg, R., Hawke, J., Schlicht, M., Gee, J., Stanford, S., and Bahadur, R. (2014). The Velo gripper: A versatile single-actuator design for enveloping, parallel and fingertip grasps. Int. J. Rob. Research, 33(5):753–767.

[Lee et al., 2018] Lee, D.-H., Coltin, B., Morse, T., Park, I.-W., Fluckiger, L., and Smith, T. (2018). Handrail detection and pose estimation for a freeflying robot. Int. J. Adv. Robot. Syst., 15(1).

[Astrobeer Guest Science Guide, 2017] Astrobeer Guest Science Guide, 2017: <https://www.nasa.gov/sites/default/files/atoms/files/irg-ff029-astrobee-guest-science-guide.pdf>

[A. Mora et al., 2018] A. Mora, R. Garcia Ruiz, P. Wofford, V. Kumar, B. Van Ross, A. Kattahagen, J. Barlow, L. Fluckiger, J. Benavides, T. Smith, M.

Bualat. Astrobe: Current Status and Future Use As An International Research Platform.

[Tanishima et al., 2018] Tanishima, N., Mitani, S., Shigeto, S., Matsumoto, Y., Arai, Y., Goto, M., and Suzuki, S. (2018). Effective and accurate method for ground and on-orbit verification of control systems for free-flying robot with low thrust force. In Proc. Int. Symp. on Artificial Intelligence, Robotics and Automation in Space (i-SAIRAS)

[Crusan et al., 2018] Crusan, J. C., Smith, R. M., Craig, D. A., Caram, J. M., Guidi, J., Gates, M., Krezel, J. M., and Herrmann, N. B. (2018). Deep Space Gateway concept: Extending human presence into cislunar space. In Proc. IEEE Aerospace.

[NASA ISAAC]
https://ntrs.nasa.gov/search.jsp?R=20190029054&hterm_s=ISAAC&q_s=N%3D0%26Ntk%3DAI%26Ntt%3DISAAC%26Ntx%3Dmode%2520matchallpartial] &
[https://gameon.nasa.gov/gcd/files/2019/04/ISAAC_FS_FINAL-4-26-19.pdf]

[Bualat et al., 2018] Bualat, M. G., Smith, T., Smith, E. E., Fong, T., Wheeler, D., and the Astrobe Team (2018). Astrobe: A new tool for ISS operations. In Proc. SpaceOps (AIAA 2018-2517).

[SAWG0719, 2019] Taken from <https://www.nasa.gov/sites/default/files/atoms/files/2019-07-sawg-1.zip>, on 01 October 2019.