

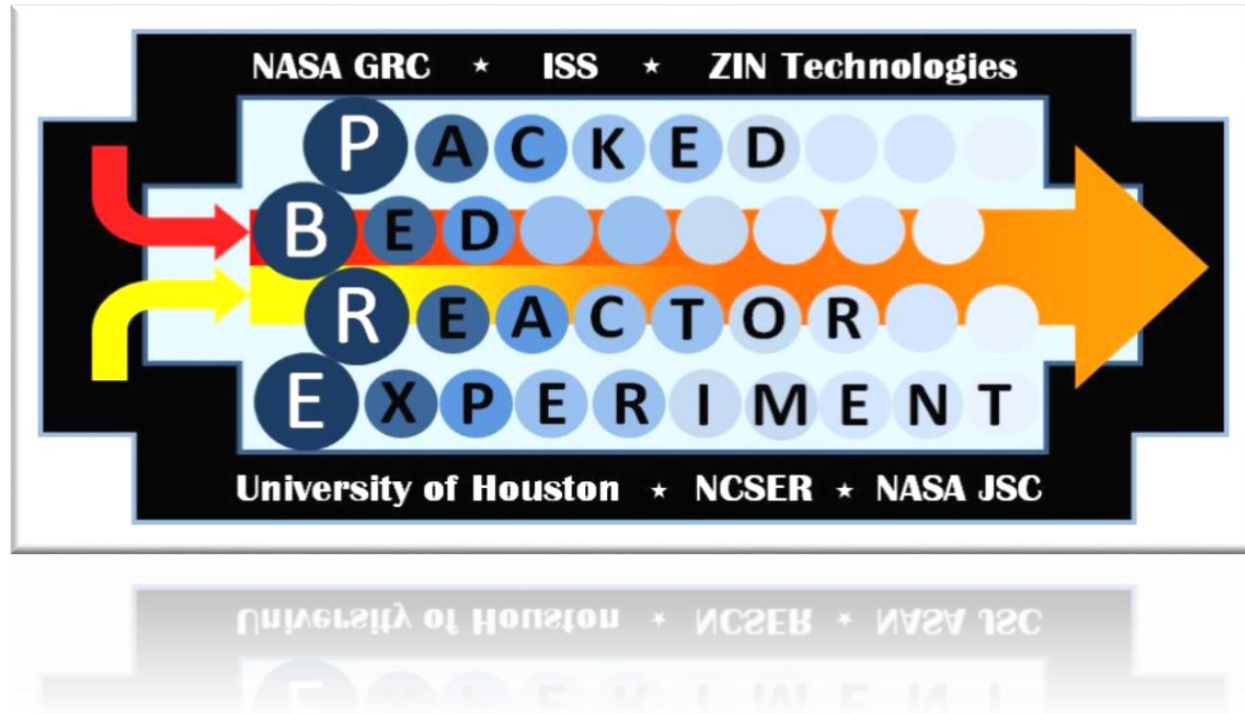

Packed Bed Reactor Experiment Capabilities



Brian Motil, *NASA Glenn Research Center*



PBRE - 1

- Developed by ZIN Technologies – launched December 6, 2015
- System Resources:
 - total mass: 147 kg
 - max power: 400 watts
 - data storage: 8 TB
- Major hardware components
 - Avionics Module
 - Data Acquisition Module
 - Water Control Module
 - Gas Control Module
 - Test Module 1 – glass beads
 - Test Module 2 – Teflon beads



Cygnus CRS OA-4



PBRE - 1

Objectives:

- Investigate the role and effects of gravity on gas-liquid flow through porous media.
- Develop/validate scaling laws and design tools for future fixed packed bed reactors in 0-g and partial-g environments, including start up and transient operations.
- Identify strategies to recover single phase beds from undesired gas bubbles.
- **Provide test fixture for future two-phase flow components.**
- Develop and validate gas holdup models such as B. Guo, D.W. Holder & L. Carter, Physics of Fluids (2004)
- By removing the influence of gravity, study the effects of other important forces in flow through porous media (inertial, viscous and surface tension).

Approach:

- Full range of gas (nitrogen) and liquid (water) flows anticipated in thermal and life support systems. Testing spans two orders of magnitude of Liquid and Gas Re.
- Critical diagnostics and data collection. Capability to add/upgrade diagnostics.
- Interchangeable beds (up to 24 inches long by 5 inches in diameter).
- 3 mm packing – 2 types of packing (wetting and non-wetting).





PBRE-1 Operations*

More than 1800 test points collected over four successive operations

Ops 1: 6/1/16 – 6/24/16

- Glass Beads
- 226 test points
- Completed full test matrix (SS, Transient, Bubble Generation)

Ops 2: 12/1/16 – 12/21/16

- Glass Beads
- 356 test points
- Completed refined test points based on transitions observed in Ops 1

Ops 3: 12/28/16 – 1/31/17

- Teflon Beads
- 954 test points
- Completed full test matrix (SS, Transient, Bubble Generation)
- Plus additional refined test points similar to Ops 2

Ops 4: 2/1/17 – 2/10/17

- Glass Beads
- 288 test points
- Original test matrix with increased magnification



Tim Kopra



Peggy Whitson

* *Results discussed in separate presentation*



Requirements for Fluids/Flow Control

Fluid Properties

- Water and ISS supplied nitrogen gas (mechanically separated after test section)
 - Water is recirculated
 - Gas is vented to cabin (no restrictions other than it must be free of droplets)
- Biocide added to water, but surface tension must remain constant (0.065 to 0.072 dyne/cm)
- No foaming or frothing

Flow rates:

- Liquid flow controllable between 0 - 150 liters/hr
- Gas flow controllable between 0 - 1.1 kg/hr (max limited by ISS)

Test Section

- On orbit replaceable within cylindrical envelope of 5 inches diameter x 24 inches long
 - Packed beds
 - Filters
 - Particulate filter
 - Pleated filter
 - Flow restrictors
 - Flex hoses
- Pressure drop up to 50 psi across test section



Flow Controls and Measurements

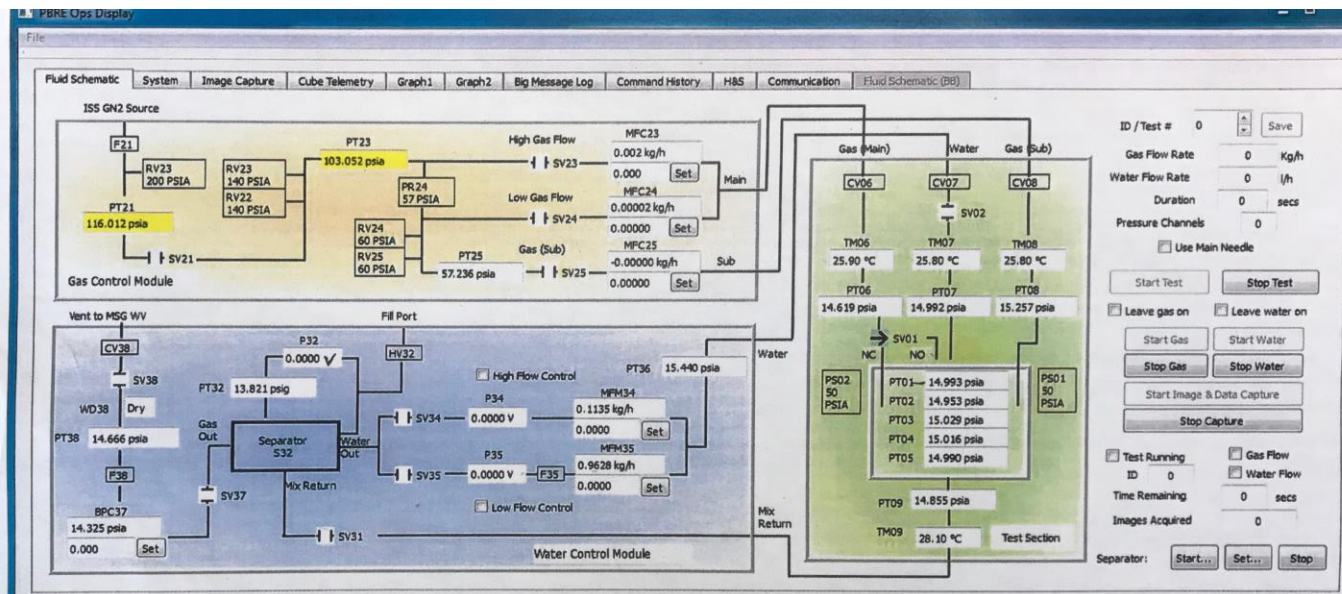

Fluid	Min Flow Rate	Max Flow Rate	Range	Increment between set points	Control
Gas (kg/hr)	0	1.1	G < 0.01 0.01 < G < 0.1 G > 0.1	0.0005 0.01 0.1	+/- 0.0002 +/- 0.005 +/- 0.05
Liquid (kg/hr)	0	150	L < 20 L > 20	1 5	+/- 0.5 +/- 1

Accuracy of Measurements

Gas flow rates: +/-1% of actual flow for G > 0.01 kg/hr; and +/-2% of actual flow for G < 0.01 kg/hr

Liquid flow rates: +/-1% of actual flow.

Packed Bed Reactor Experiment



Requirements for Diagnostics

- Gas and Liquid flow rates:
 - +/- 1% actual flow at 10 Hz.
- Absolute Pressure:
 - +/- 0.1 psi at 10 Hz.
- Temperature:
 - +/- 0.5 deg C at 1 catalyst bed.
- Differential Pressure:
 - +/- 0.1 psi at 200 Hz (5 locations) .
- Video
 - Two orthogonal pairs of views.
 - Resolution: 1000 pixels in direction of flow with 6x optical zoom.
 - Selectable rates: 100, 50, 30, 5, and 2 frames per second.

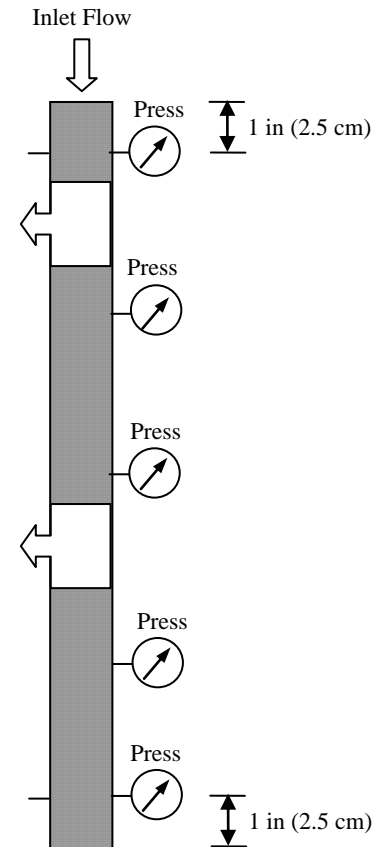



PBRE Modules

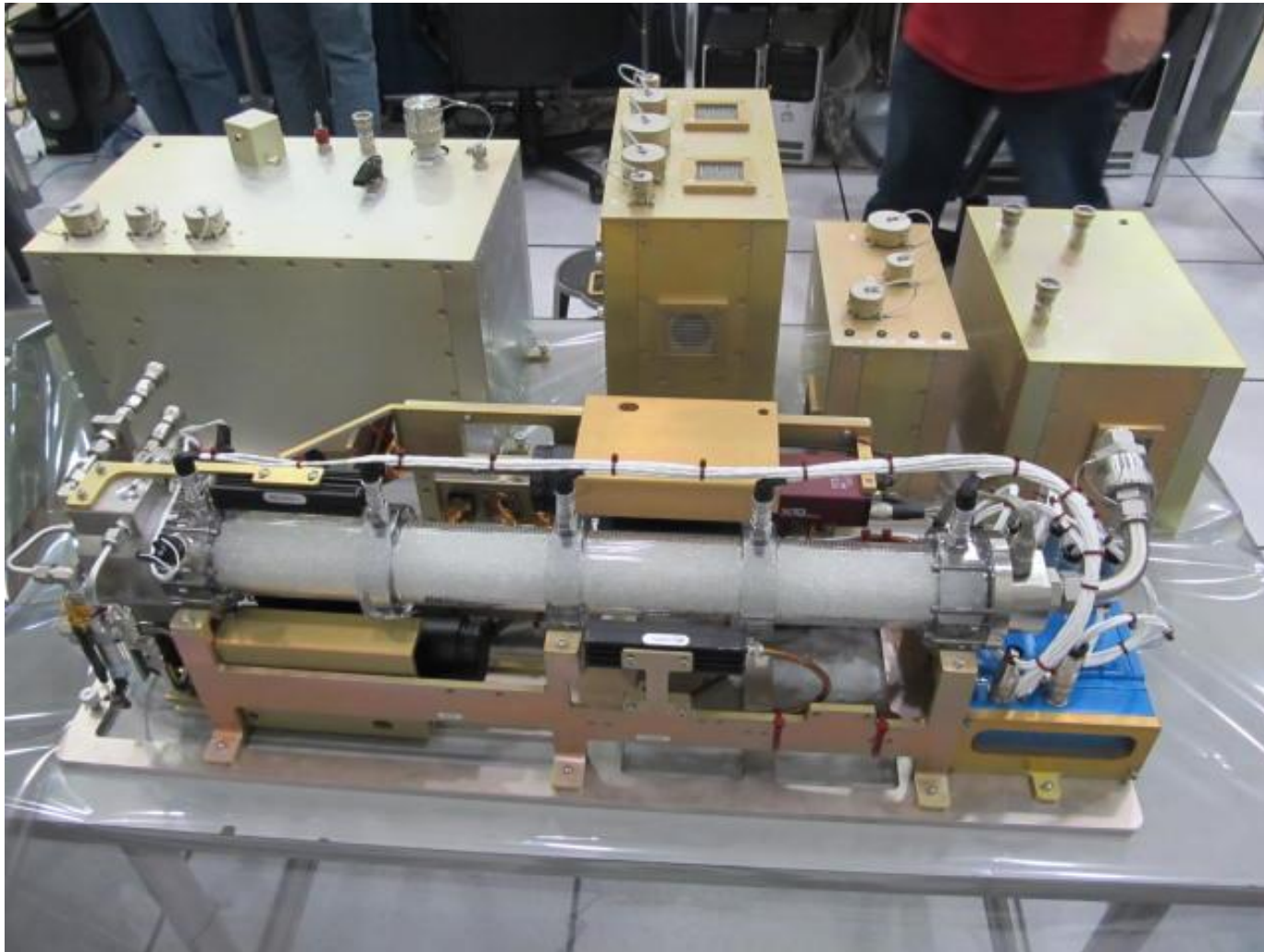

Packed Bed Reactor Experiment



PBRE as Integrated into the MSG

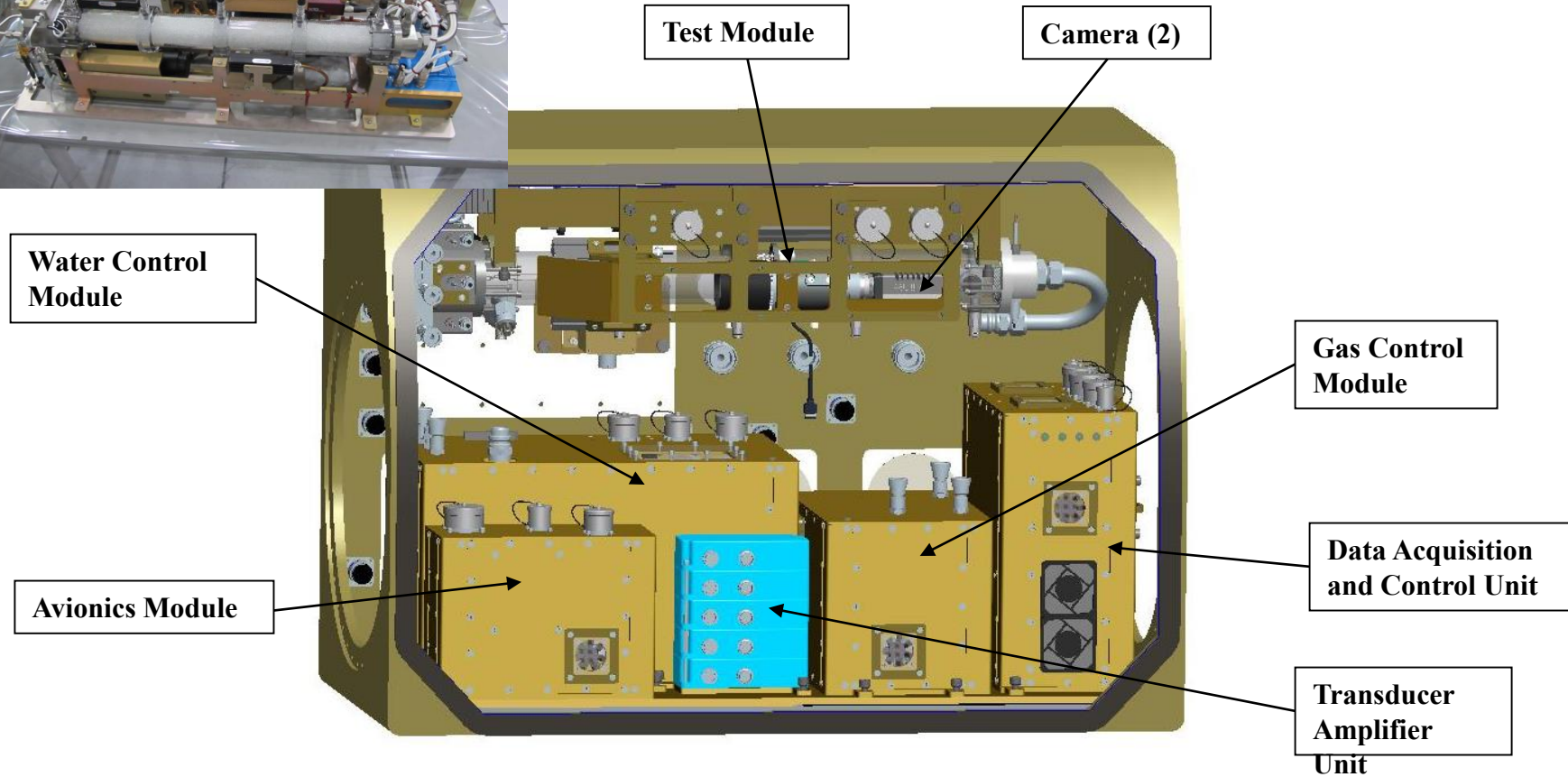
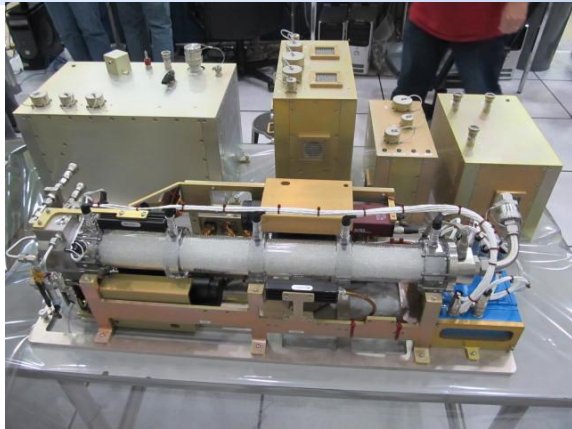

Packed Bed Reactor Experiment



Fluid Diagram with Fluid Interfaces

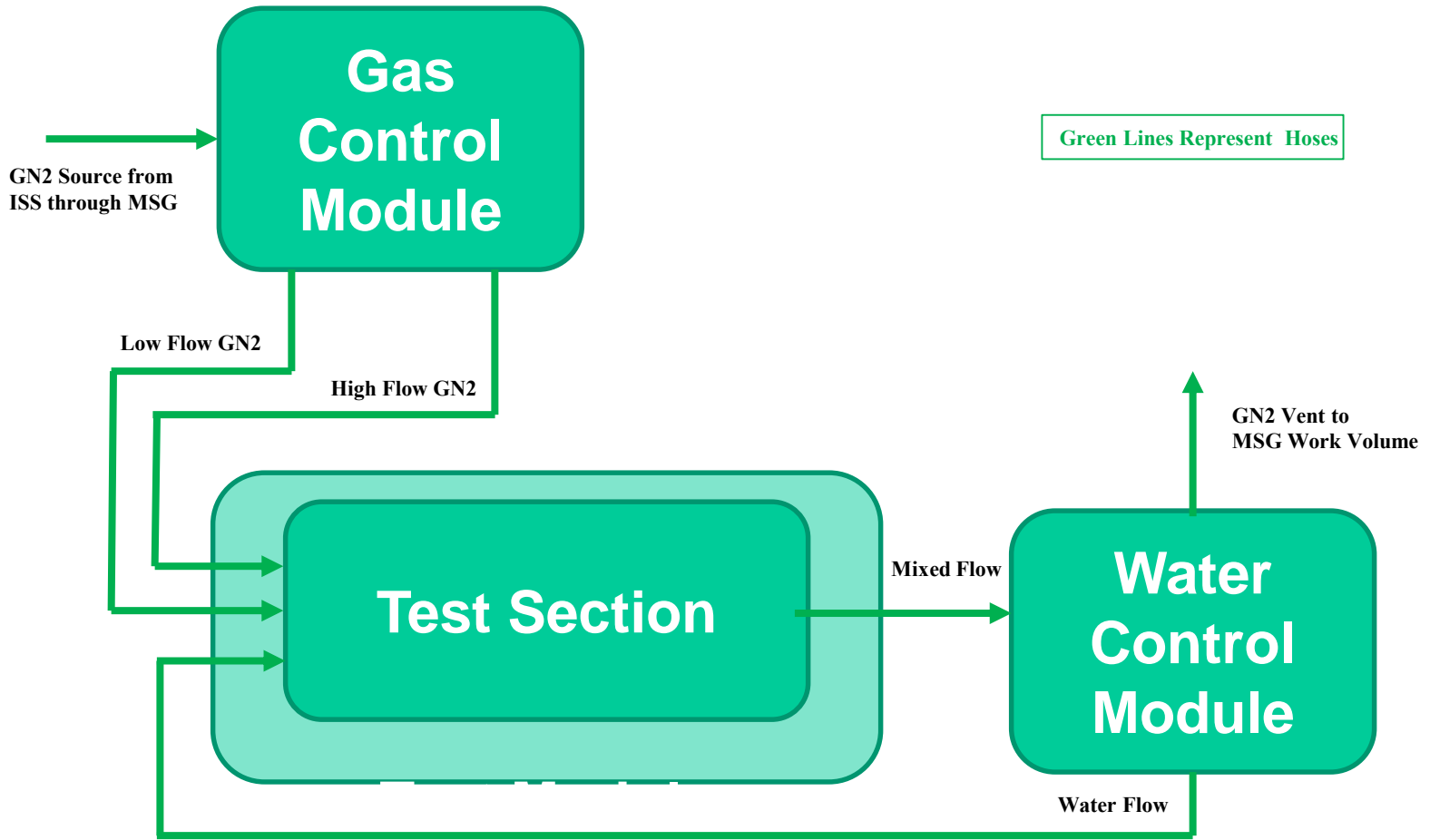

Packed Bed Reactor Experiment



Test Module with Test Sections

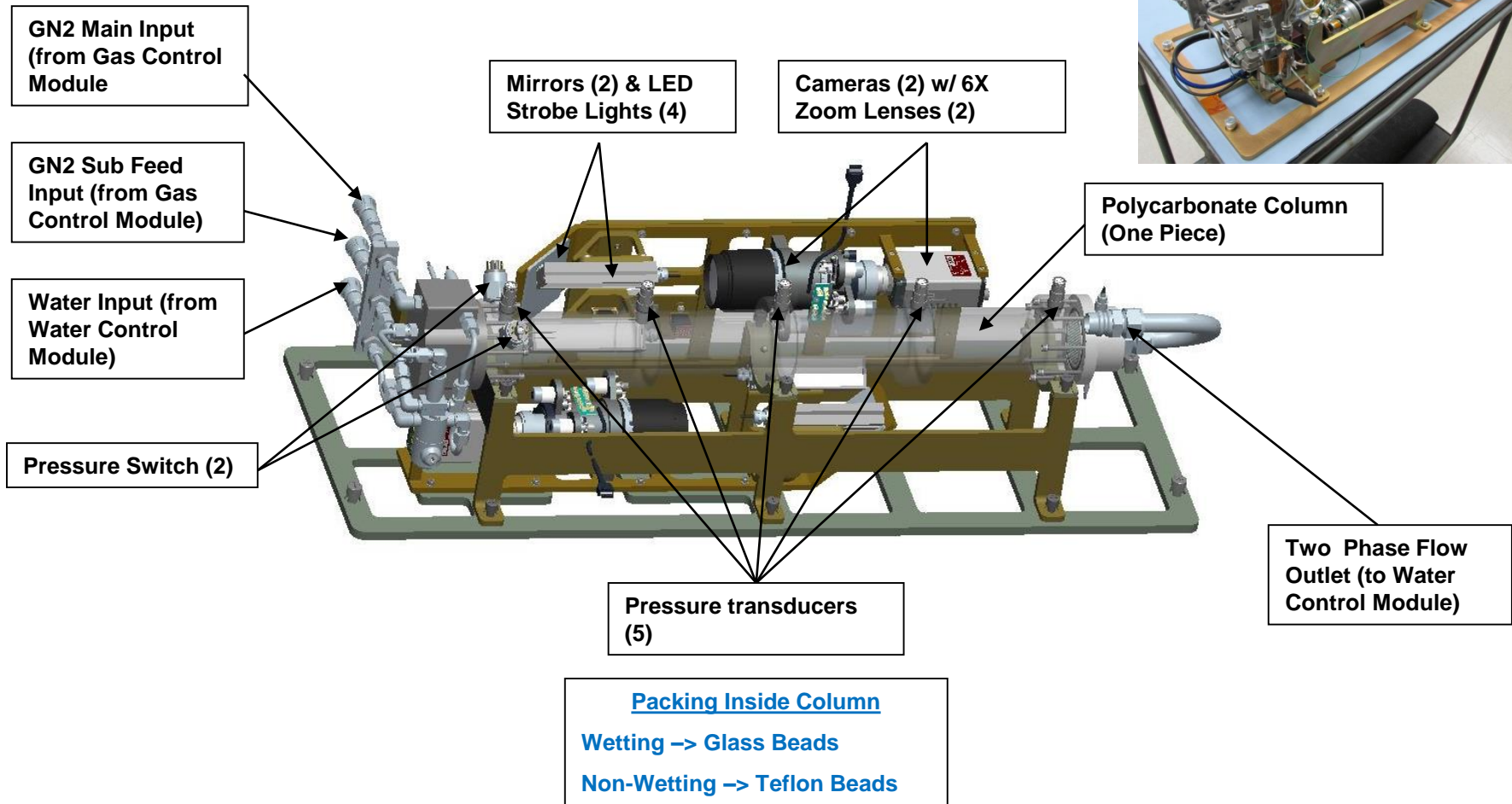

Packed Bed Reactor Experiment



Water Control Module

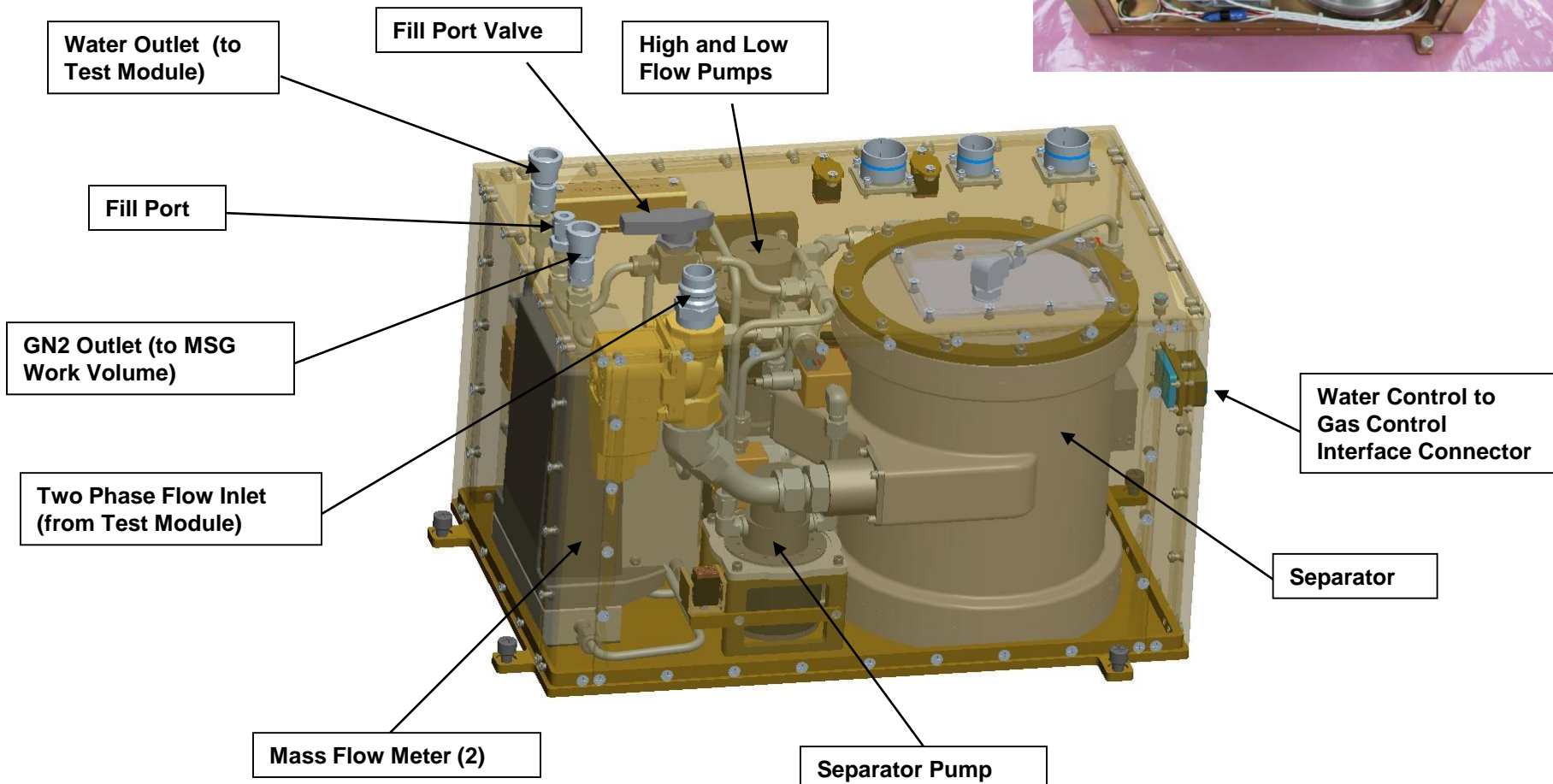

Packed Bed Reactor Experiment



Gas Control Module

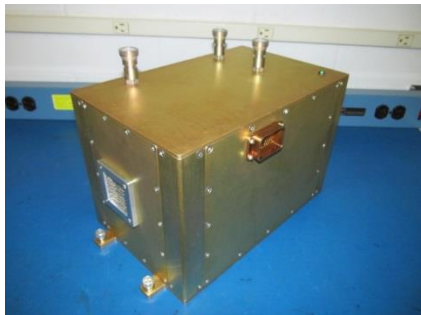
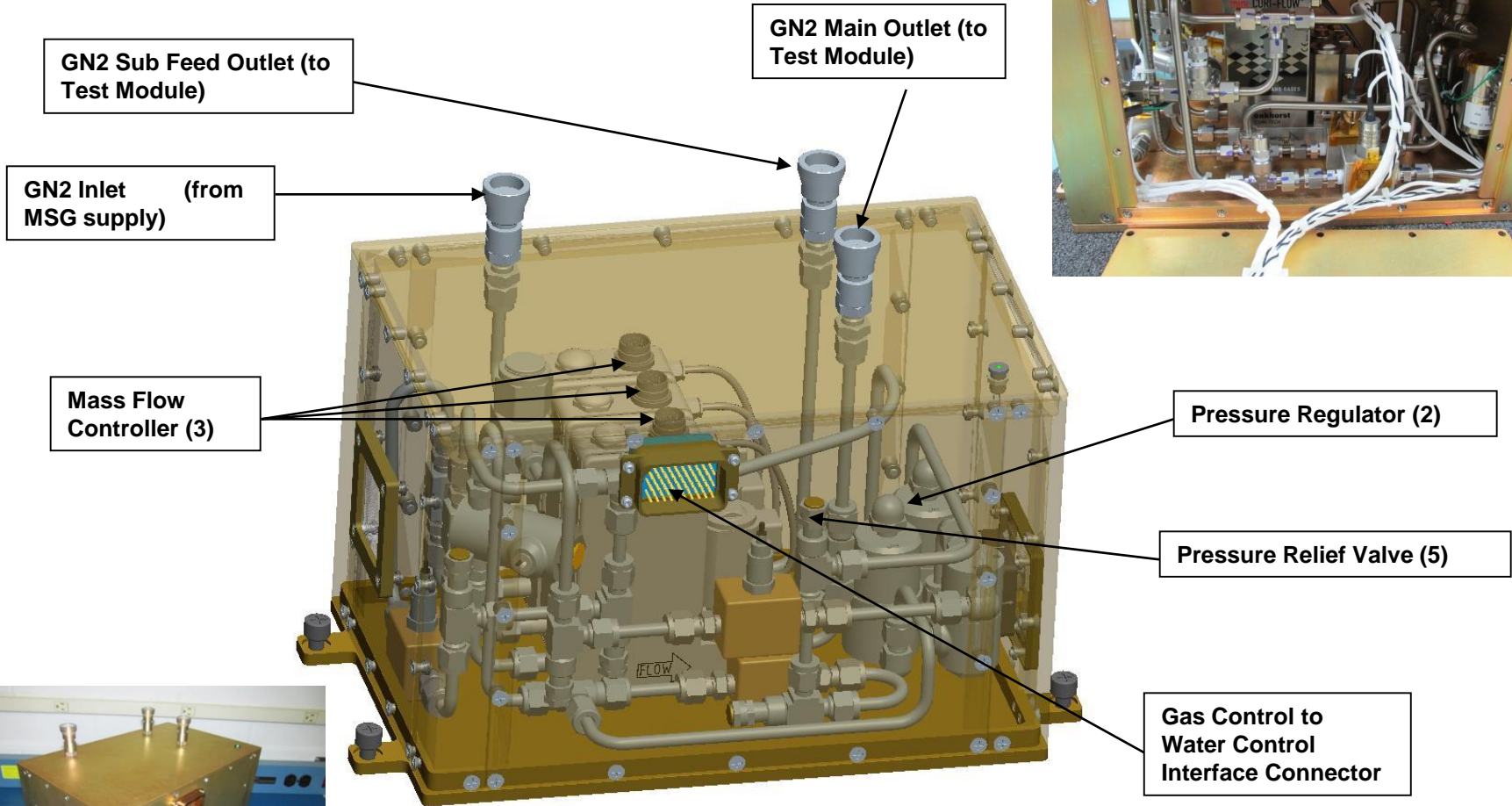

Packed Bed Reactor Experiment



Camera Specifications and Capabilities

PBRE Camera

- Camera Native Resolution → 1024 x 1024
- Camera Area-of-Interest (AOI) Readout → 1024 x 512
- Camera Framing Rate → Variable up to 170fps (at AOI 1024 x 512)
- Measured Horizontal Field-of-View → 74.4 mm at 1x, 12.5mm at 6x
- SRD specified Field-of-View → 75 mm at 1x, 12.5 mm at 6x
- Lens Remote Control → Motorized by ZIN to provide Zoom, Focus and Iris control via software
- Lens Parfocality → Focus is maintained throughout zoom range
- Lens Zoom Range → 18mm – 108mm focal length (6x Zoom)
- Strobe Flash Rate – Inline controller limits flash rate to 150pps.

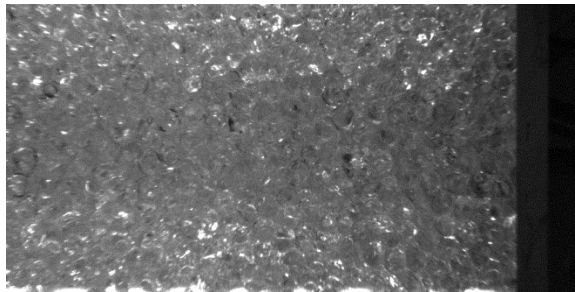

Lens Zoom - 1x

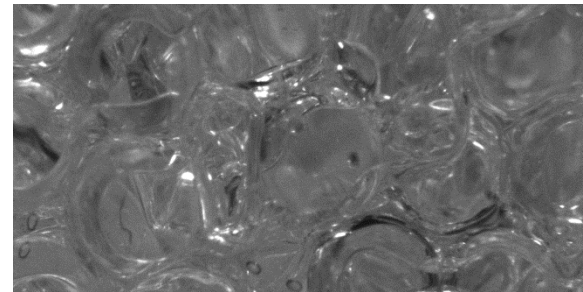

Lens Zoom - 6x

Next up...

- Increment 61 & 62 will provide the opportunity to re-fly the PBRE experiment within the Microgravity Science Glovebox.
- PBRE-1 completed ops in MSG (2/2017).
 - Included glass and Teflon packing.
 - Some hardware issues reduced some of the original science (mainly with high speed video) – has been resolved for re-flight.
- PBRE-2 will extend test matrix to different size packing.
- PBRE-WR will extend test matrix to different type of packing (alumina).
- Developing “replaceable cradle” concept to remove test sections on orbit to increase utilization.

