



# Results of NASA's Magnetic Gear Program to Date

**Thomas Zachary Justin**  
**Tallerico Cameron Scheidler**

**NASA Glenn Research Center**  
Materials and Structures Division  
Rotating and Drive Systems Branch

# Outline

---

- Background and Motivation
  - Concentric Magnetic Gears
- Results
  - Efficiency
  - Thermal
  - Mass
- Future Work
  - Magnetically Geared Motors
- Conclusions

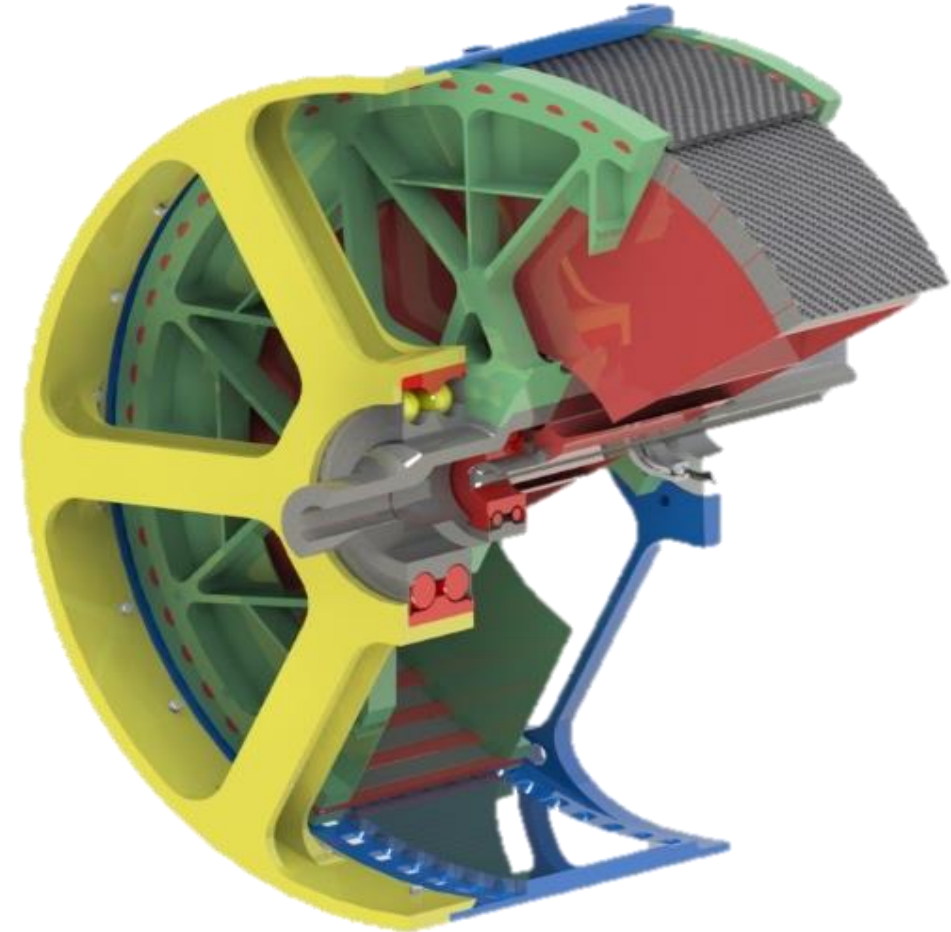

# Background & Motivation

- Electric motor driven fans used to enable electrified aircrafts
- Geared electric motor drives are lighter and/or more efficient than direct drive
- Direct drive common in concept vehicles:
  - Easier to design
  - Potentially more reliable



## Direct drive

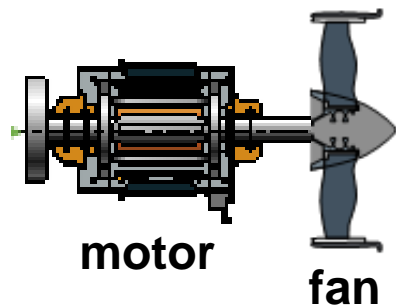

- + Simpler
- Non-optimal motor and/or fan

## Geared drive

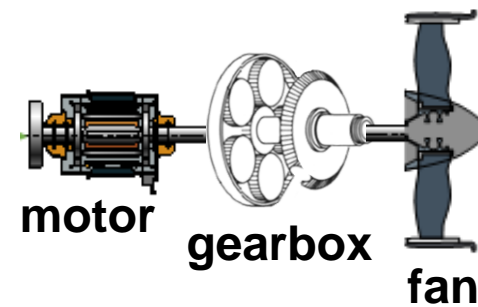

- + Optimized motor & fan
- More complex
- Potentially less reliable

# Mechanical vs Magnetic Gears

## Mechanical gearing

### Pros

- + High / very high torque/mass (**specific torque**)
- + High / very high efficiency
- + Mature technology

### Cons

- Contact-related wear & failure
  - Requires lubrication system(s)
  - Routine & costly maintenance
- Strong tonal vibration & cabin noise

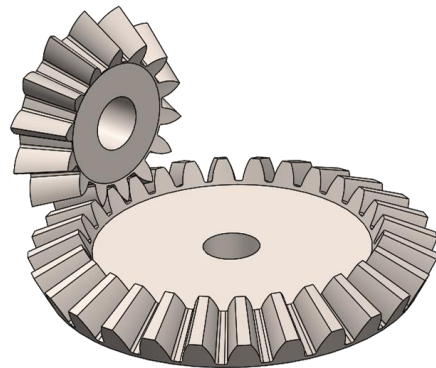
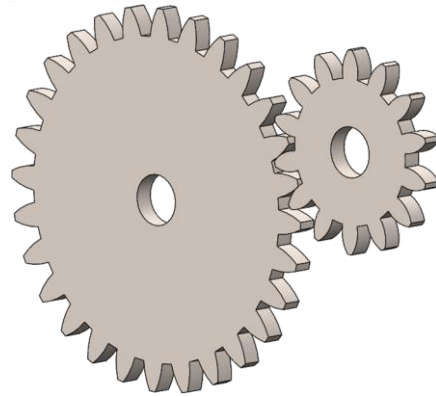

## Magnetic gearing

### Pros

- + Non-contact
  - + No lubrication
  - + Low maintenance
- + Easily integrated in electric machines
- + Potentially low vibration

### Cons

- Unknown limits on specific torque & efficiency
- Magnet temperature limit
- Individual magnet interaction weaker than 1 gear tooth pair

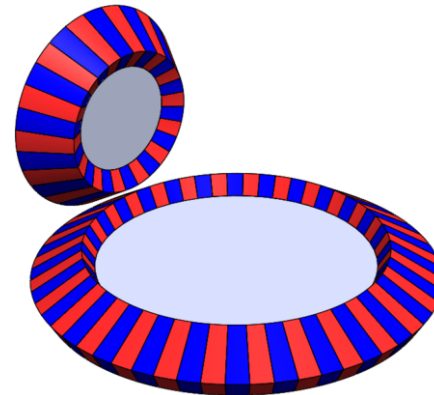
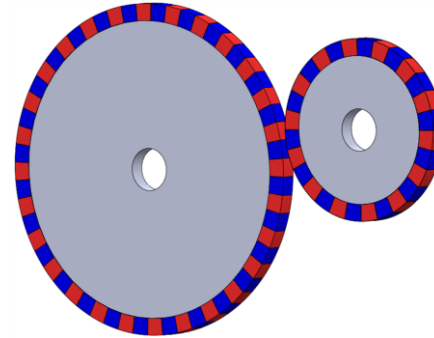

# NASA's Magnetic Gear Program

## Phase I

2017

- How do they work? (PT-1)
- Can they be lightweight? (PT-2)

## Phase II

2018-2019

- Can they be efficient? (PT-3)
- Can they be efficient and light weight? (PT-4)

## Phase III

2019-2020

- How to pair them with motors?
- Can they be reliable?

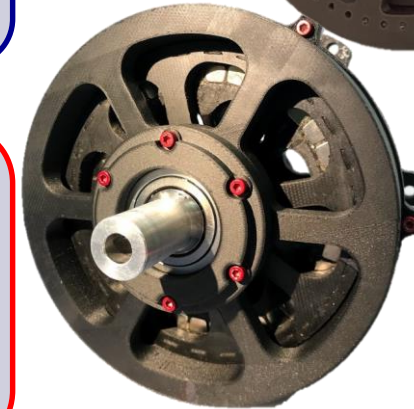

PT-2  
45 Nm/kg

PT-3 >97%  
Efficient

PT-4

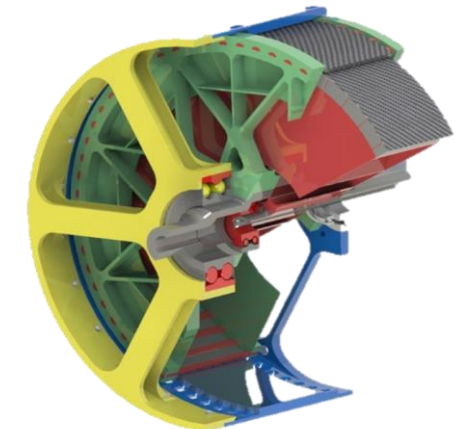

# Concentric Magnetic Gears

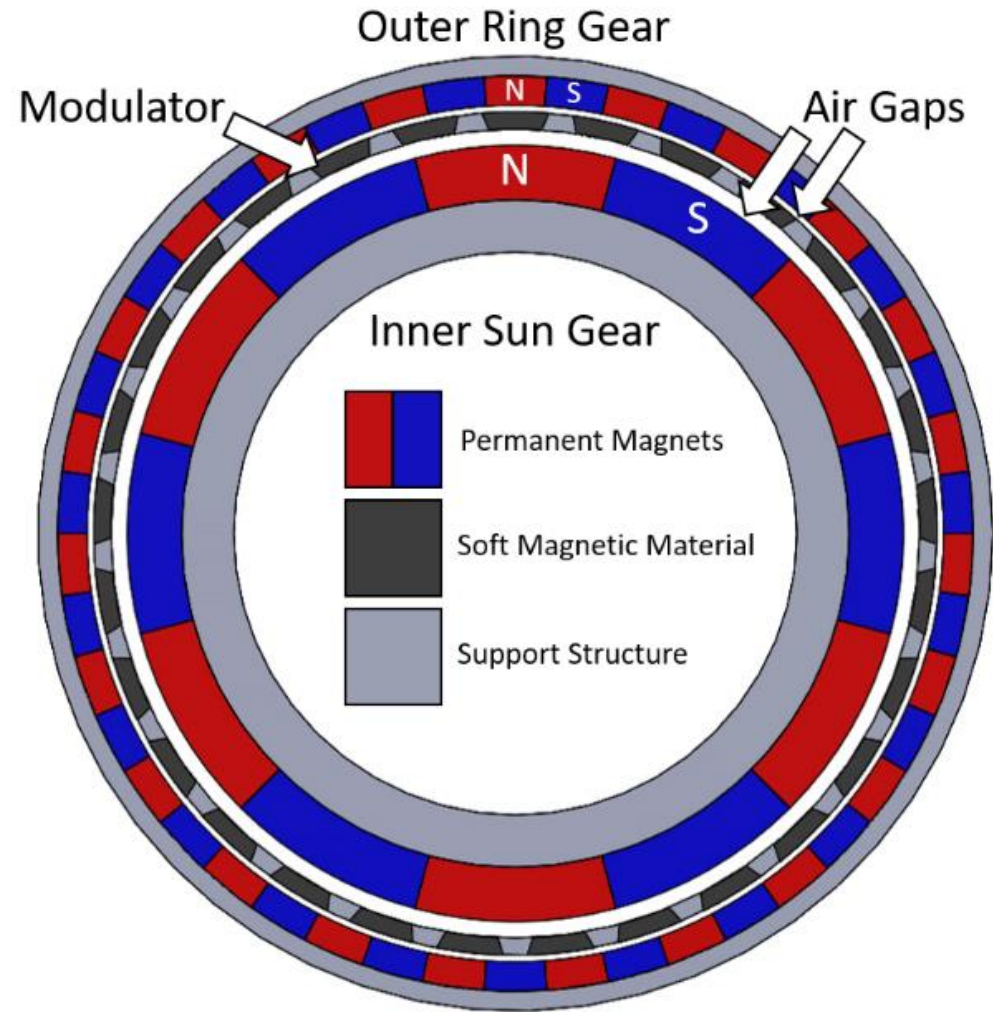

# Continuous Torque Transmission

**Mechanical Gears Require  
Matching Tooth Pitch**

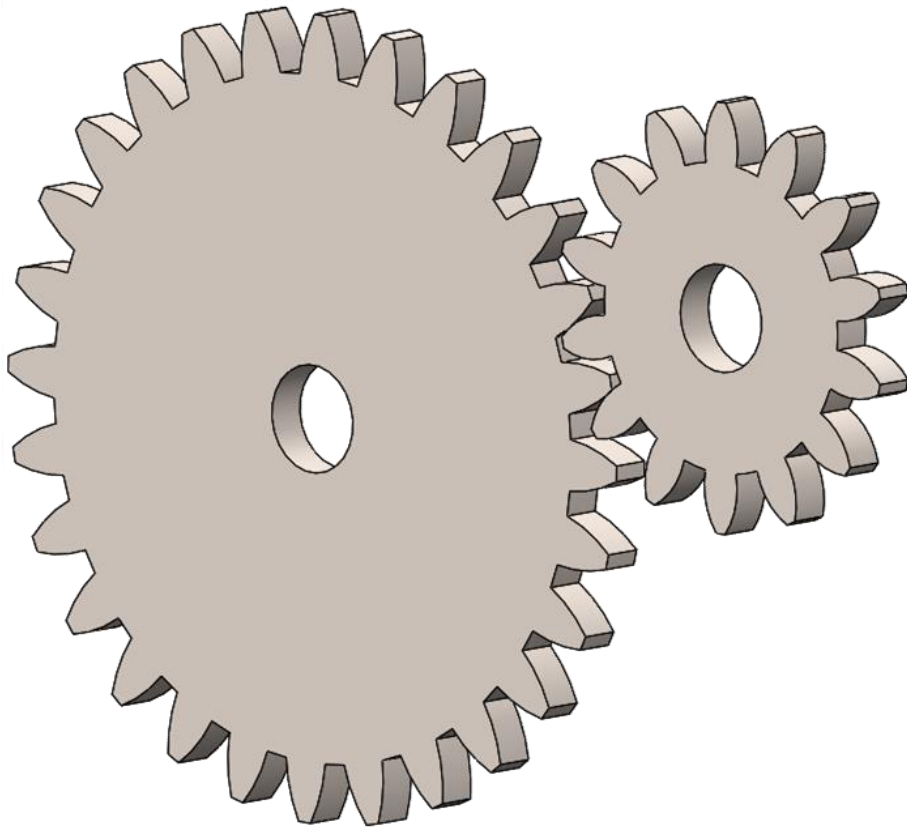

**Magnetic Gears Require Matching  
Field Spatial Harmonics**

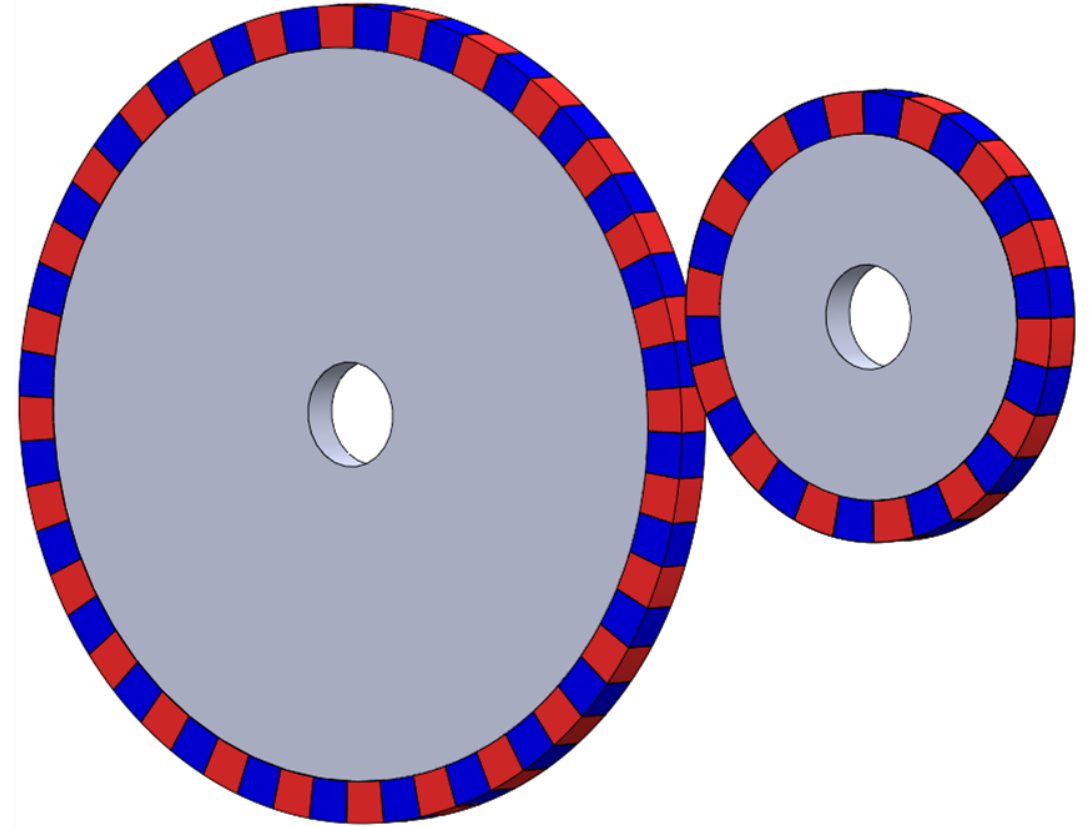

# Spatial Harmonic

- Magnetic Field Produced by a PM Rotor:
  - $B_r = A * \cos(P * \theta)$
  - $P$  = Number of Rotor Pole Pairs
  - $P$  = Spatial Harmonic Order of Flux
- In a CMG
  - PM rotor's have different  $P$
  - Modulator “modulates” flux produce by the two rotors so that the flux has matching spatial harmonic order in both airgaps

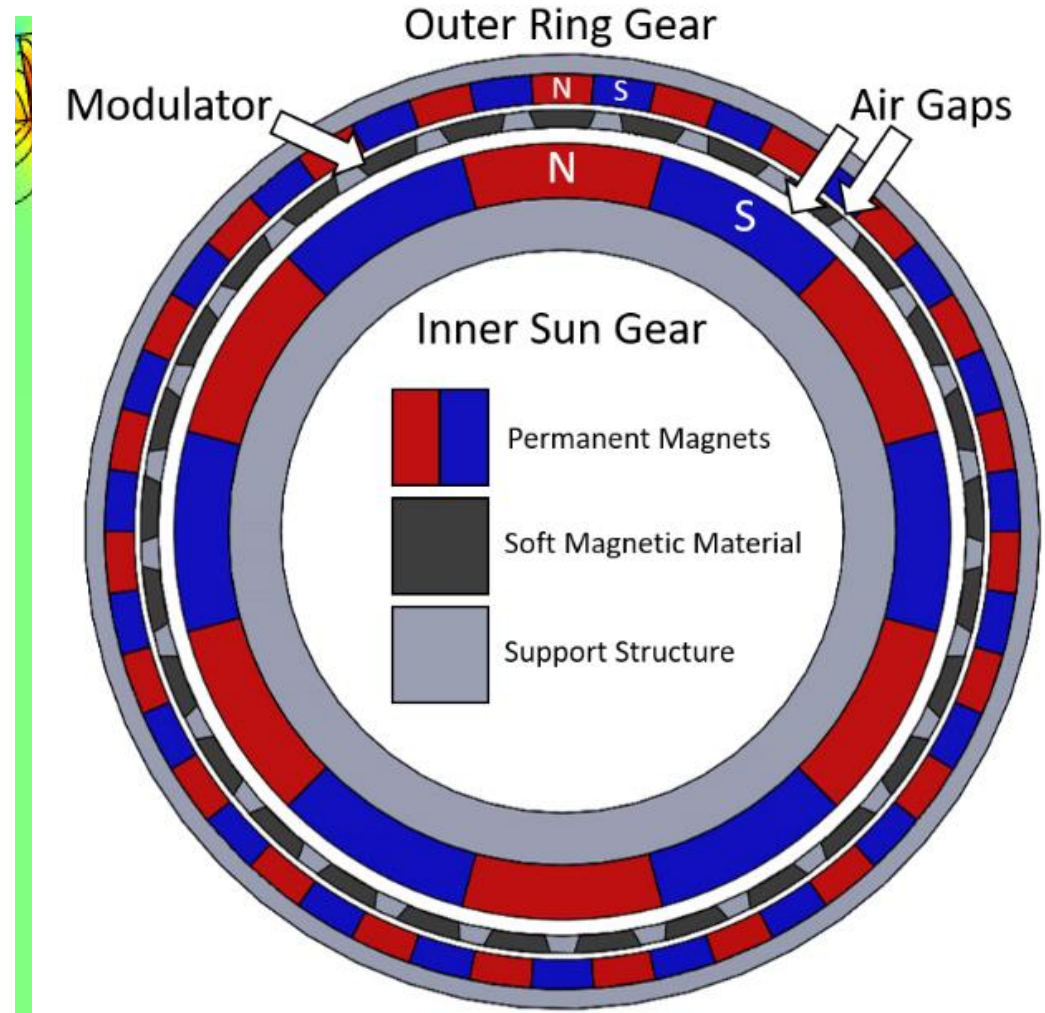

# Flux Modulation

$$\cos(\theta) * \cos(\alpha) = \frac{1}{2} (\cos(\theta + \alpha) + \cos(\theta - \alpha))$$

$$B_{rs} = F * \cos(PR * (\theta + \delta))$$

└─ Number of Ring Gear Pole Pairs

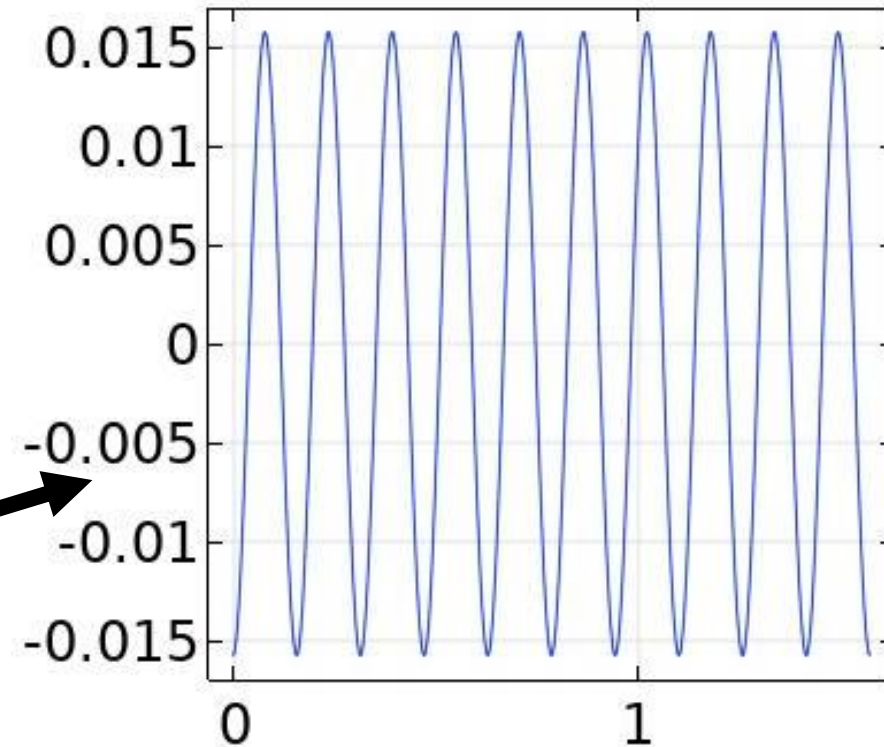
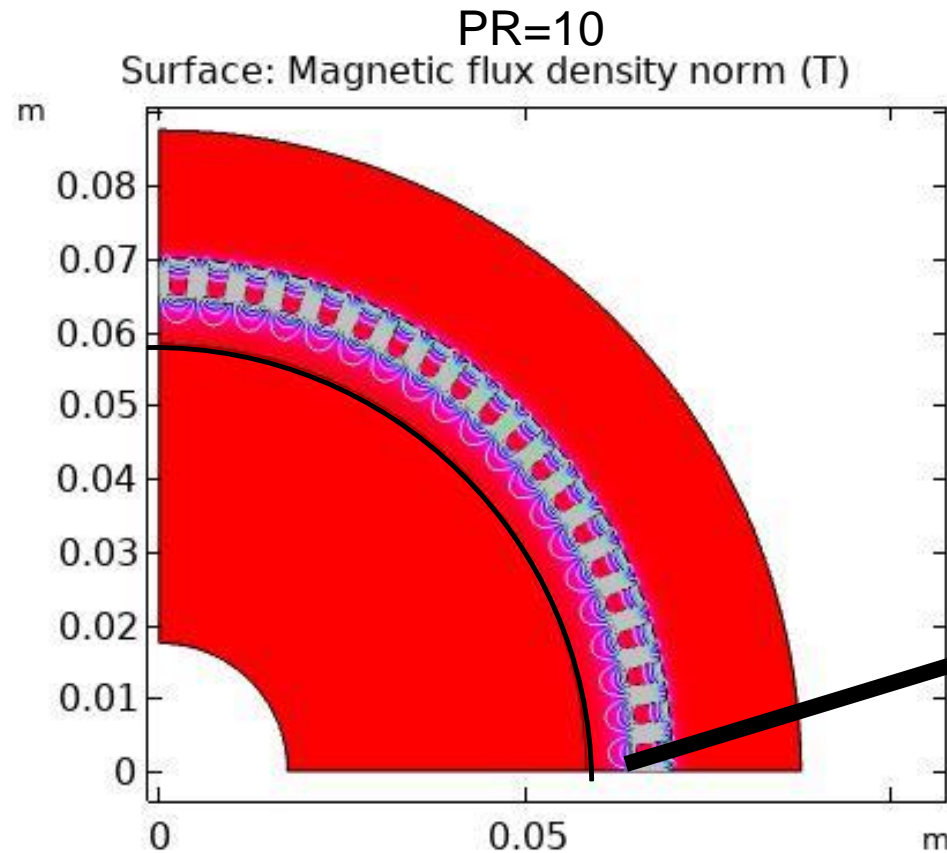

# Flux Modulation

$$\cos(\theta) * \cos(\alpha) = \frac{1}{2} (\cos(\theta + \alpha) + \cos(\theta - \alpha))$$

$$B_{rs} = F * \cos(PR * (\theta + \delta))$$

$$u = u_{avg} + u_m * \cos(Q * (\theta + \varphi))$$

Number of Pole Pieces

Q=11

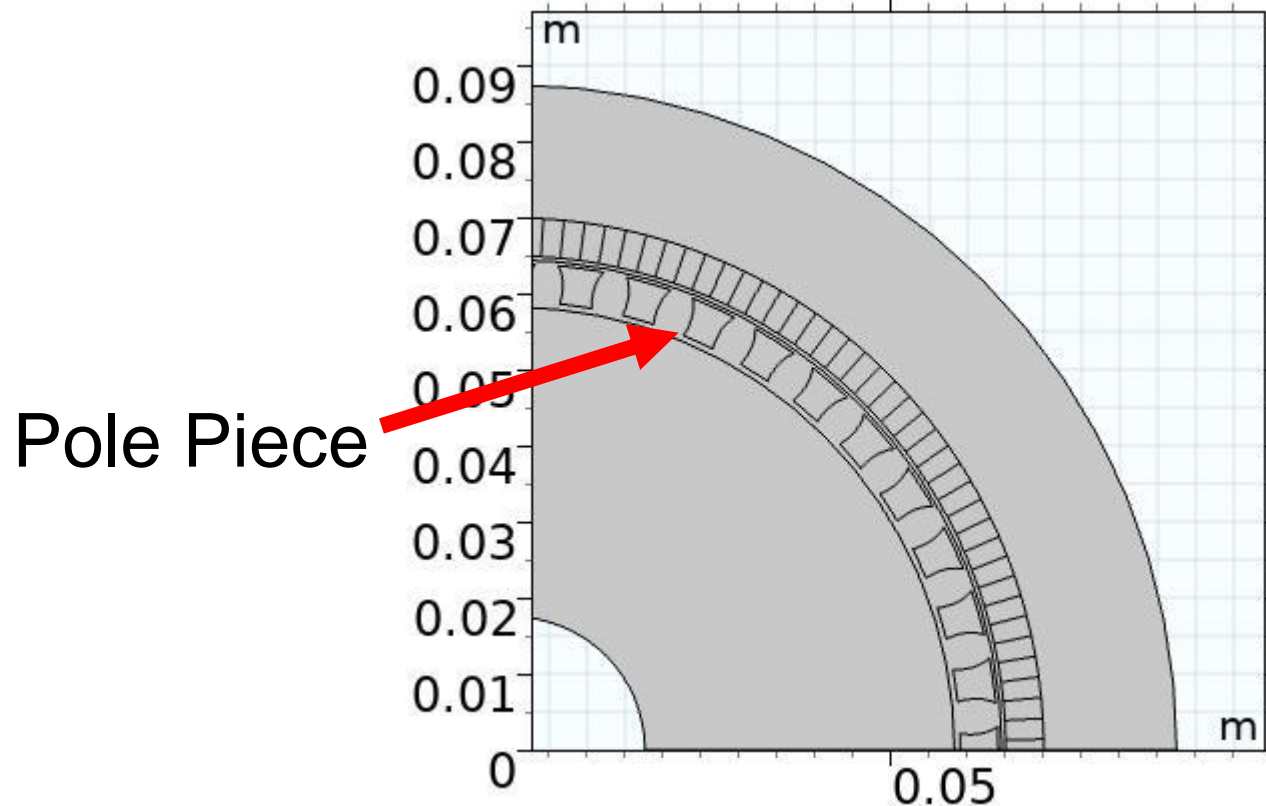

# Flux Modulation

$$\cos(\beta) * \cos(\alpha) = \frac{1}{2} (\cos(\beta + \alpha) + \cos(\beta - \alpha))$$

$$Q - PR = 11 - 10 = 1 = PS \longrightarrow \text{Sun Gear Pole Pairs}$$

## Fundamental CMG Equation

$$Q = PR \pm PS$$

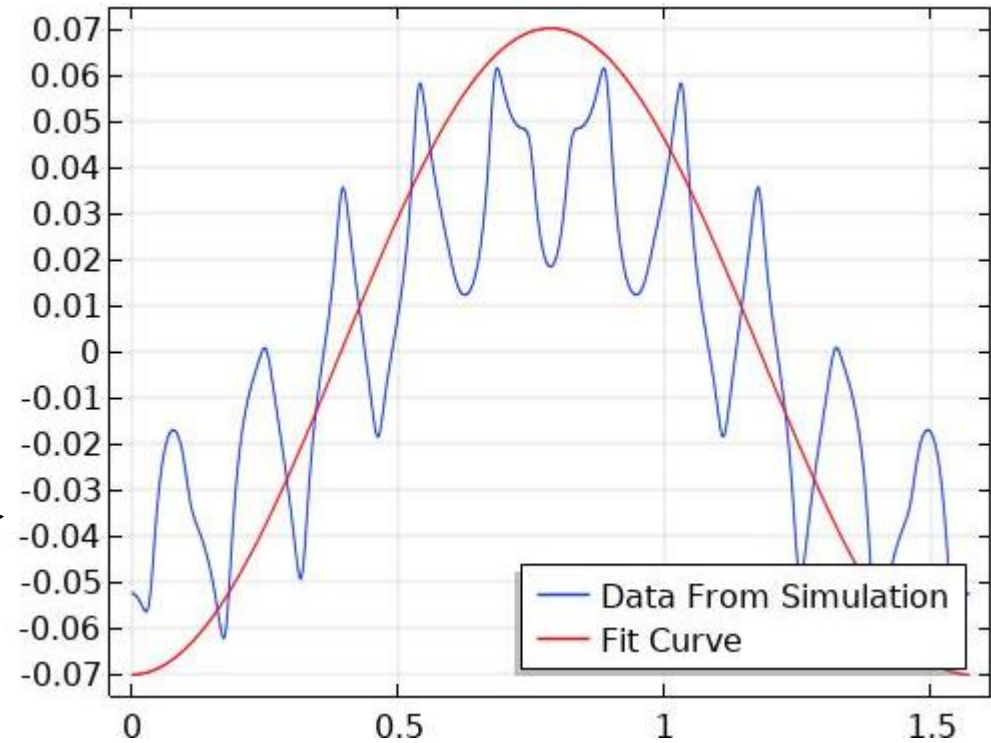
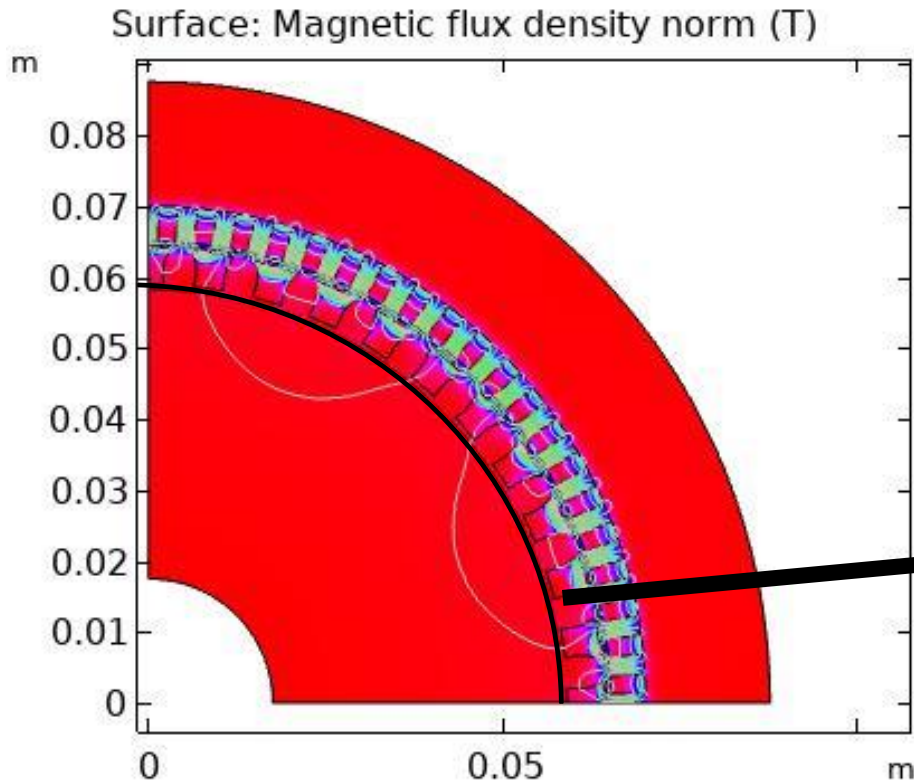

# Gear Ratio

**Mechanical planetary gear**



**Analogous concentric magnetic gear**

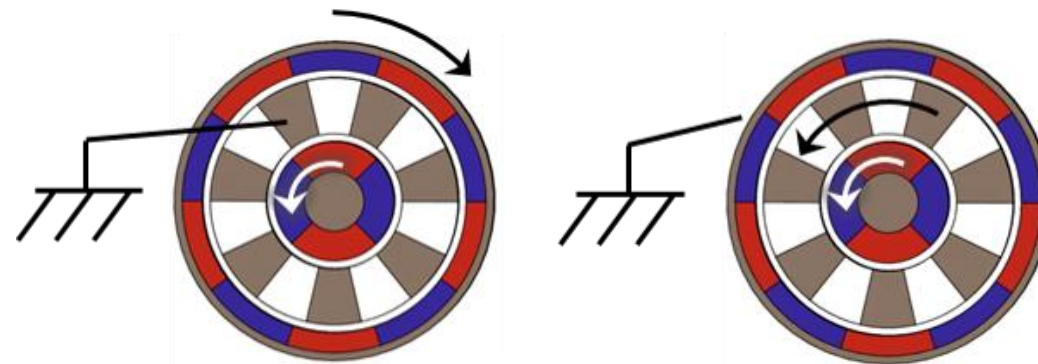
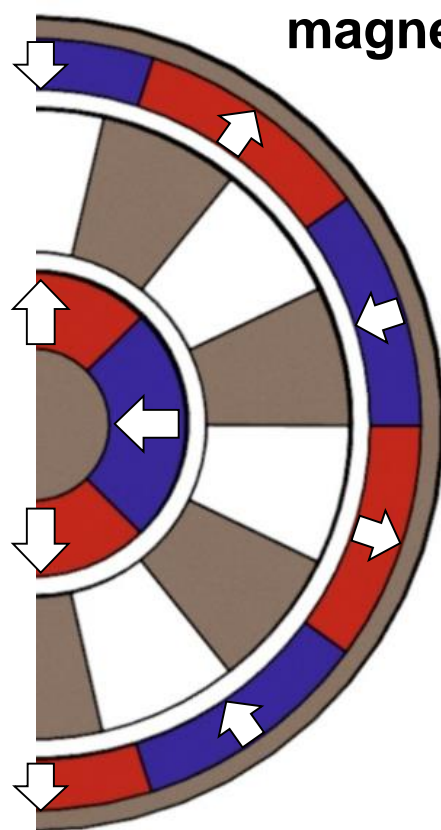

Output	Q Selection	Gear Ratio
Ring Gear	PR-PS	$\frac{PR}{PS}$
	PR+PS	
Modulator	PR-PS	$\frac{Q}{PS} = \frac{PR}{PS} - 1$
	PR+PS	$\frac{Q}{PS} = \frac{PR}{PS} + 1$

# Outline

---

- Background and Motivation
  - Concentric Magnetic Gears
- Results
  - Efficiency
  - Thermal
  - Mass
- Future Work
  - Magnetically Geared Motors
- Conclusions

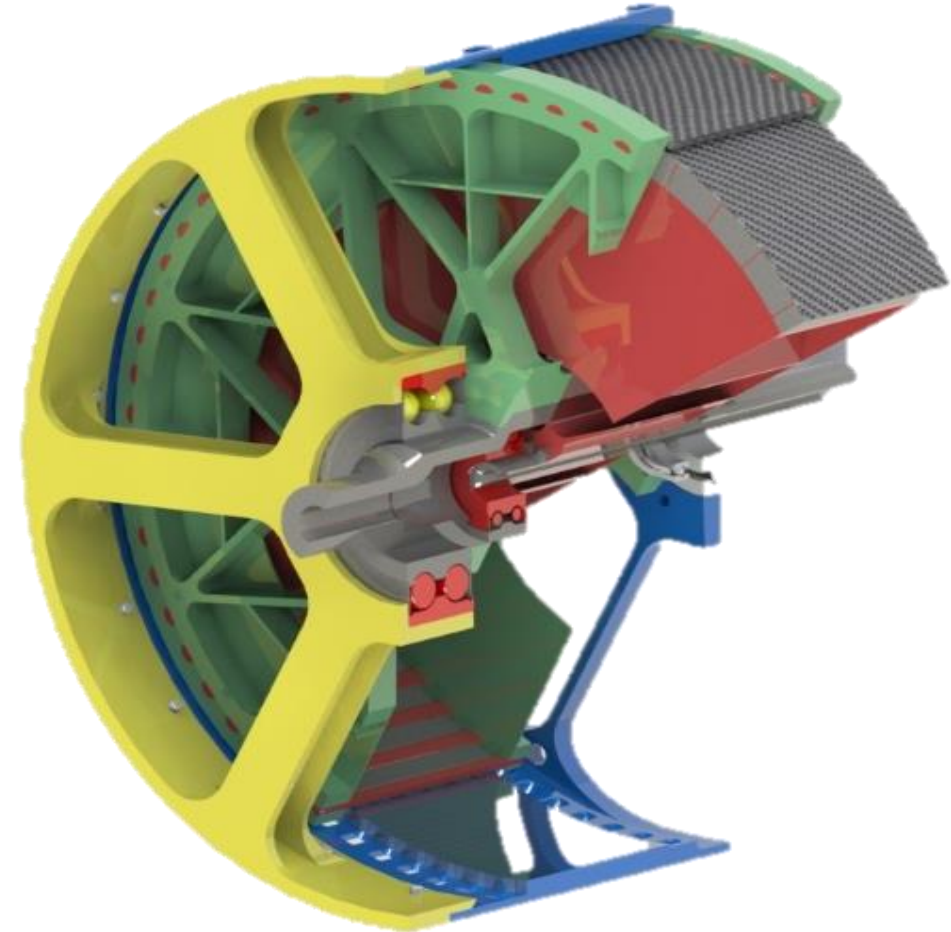

# Efficient Magnetic Gears

---

- Main loss source = eddy currents
- Time varying magnetic fields produce electrical fields:

$$\nabla \times E = -\frac{\partial B}{\partial t}$$

- Electrical fields drive currents:

$$I = \frac{V}{R}$$

- Currents produce heat:

$$Q = RI^2 = \frac{V^2}{R}$$

# Minimizing Eddy Currents

## 1. Use non-conductive (non-metallic) Structures

- Plastics
- Composites
- Ceramics (\$\$)

## 2. Laminate Electrical Components

- Laminated Electrical Steel
- Laminated Magnets
- Increases effective (Bulk) resistivity

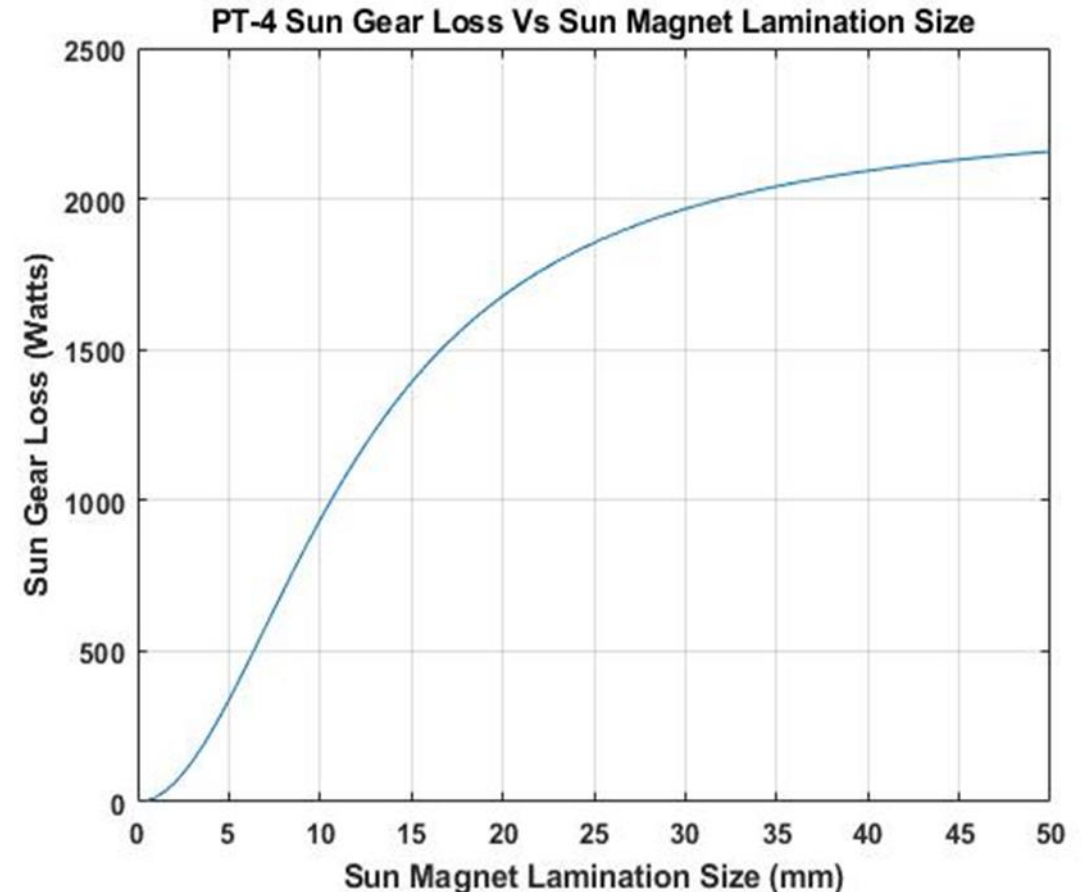

# Tested Efficiency

- NASA's PT-3
  - FeCo Pole Pieces
    - 0.1 mm laminations
  - 1 mm Magnet Lamination
    - 80 % Magnet Fill
  - Achieves >97% Efficiency
- Results discussed in Dr. Scheidler's Presentation

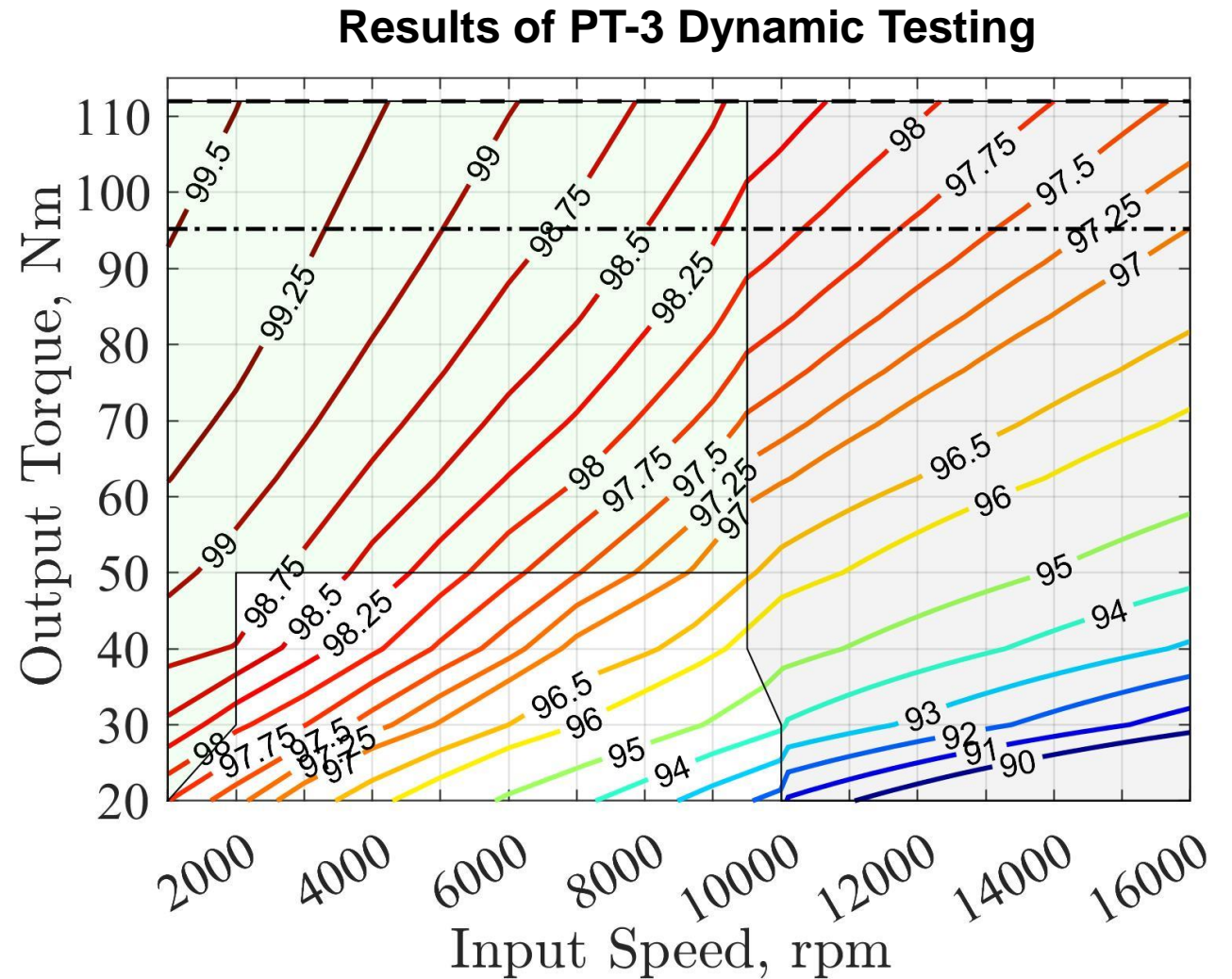

# Achievable Efficiency

## Achievable Efficiency without Magnet Laminations

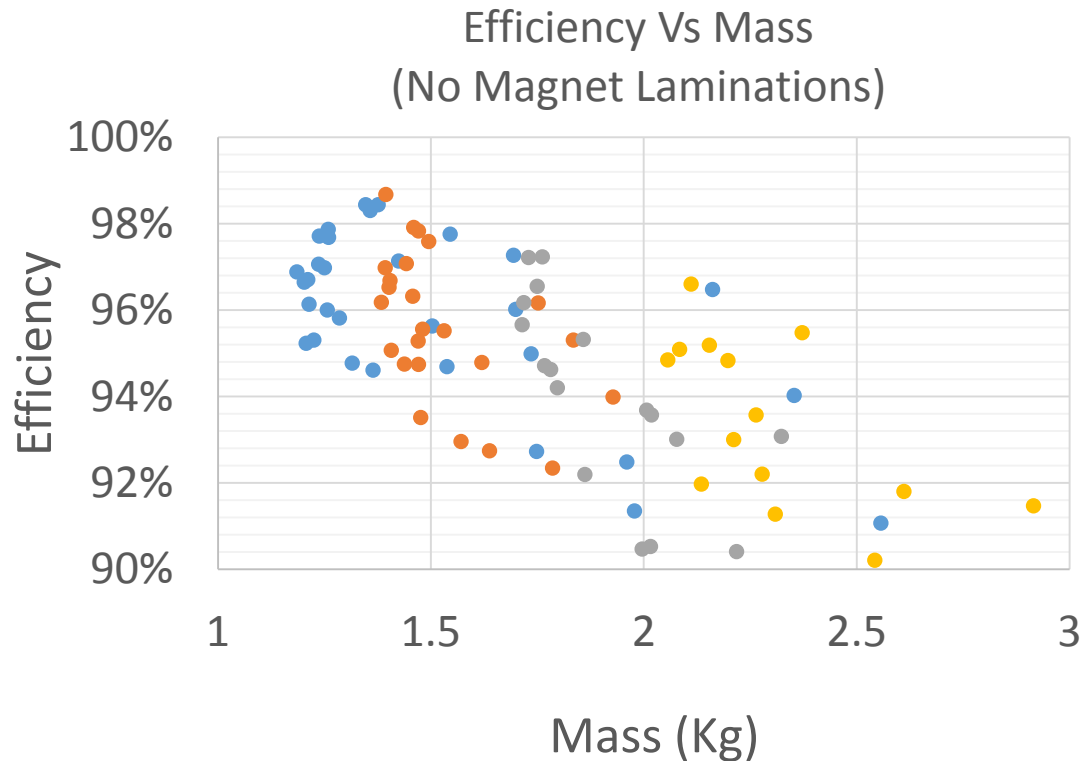

## Achievable Efficiency with Magnet Laminations (Iron Loss Dominates)

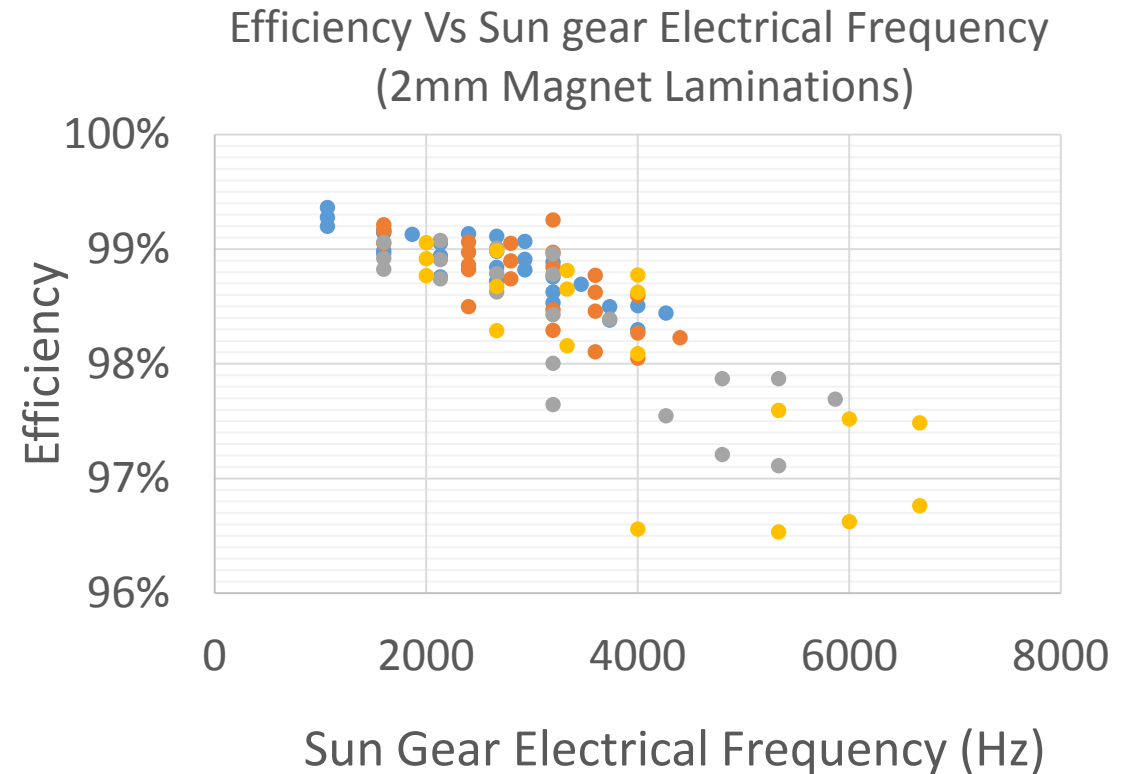

# Magnetic Gear Thermal Consideration

- As Magnet Temperature Increases
  - Remnant Flux Density Decreases
  - Torque Decreases
  - Efficiency Increases
    - At a given operating point
  - At some point magnets demagnetize
    - Ring magnets highly susceptible
    - Lower temp than catalog value

Temperature (°C)	PT-4 2D FEA Torque (Nm)	PT-4 Total Efficiency
20	370	98.50%
80	303	99%

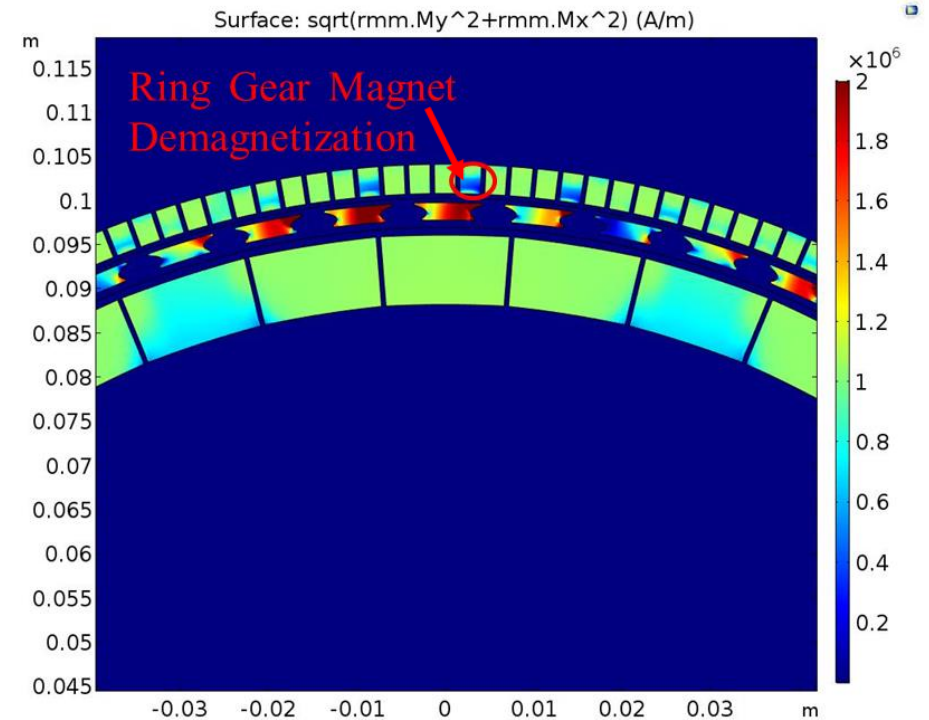

# Magnetic Gear Thermal Performance

- Efficiency Similar to Mechanical Gears
- Losses are distributed over gear volume (not line contact)
- Lubrication/Liquid cooling not needed
- PT-4
  - Self cooled centripetally pumped flow
  - 80 C magnet temperature predicted

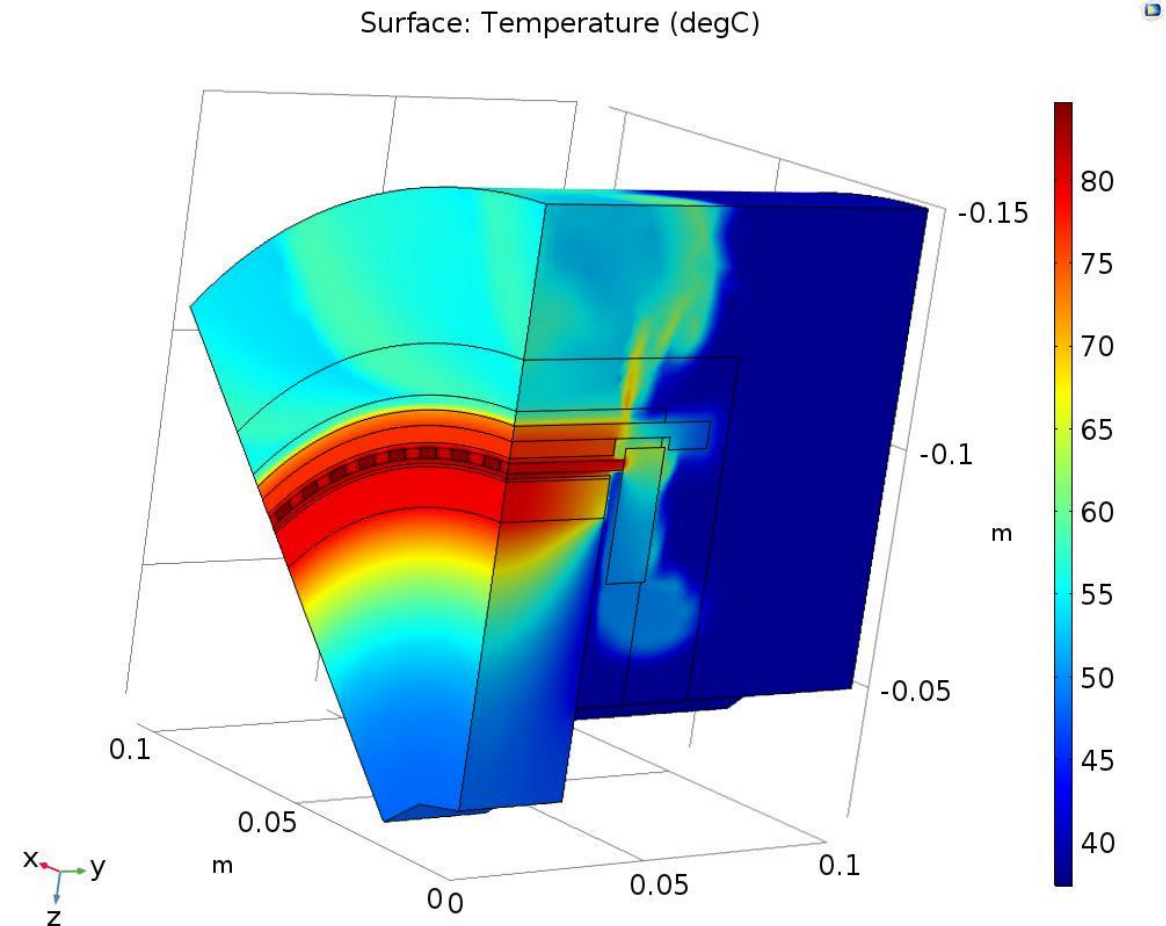

# Magnetic Gear Mass

- NASA has improved SOA of magnetic gear specific torque

Prototype	Specific Torque
Previous SOA	~20 Nm/kg
PT-1	20 Nm/kg
PT-2	46 Nm/kg
PT-3	42 Nm/kg
PT-4	49 Nm/kg

- Magnetic gears are light compared to electric motor
  - Mag Gear ~ 35 kw/kg
  - Motor ~ 10 kw/kg

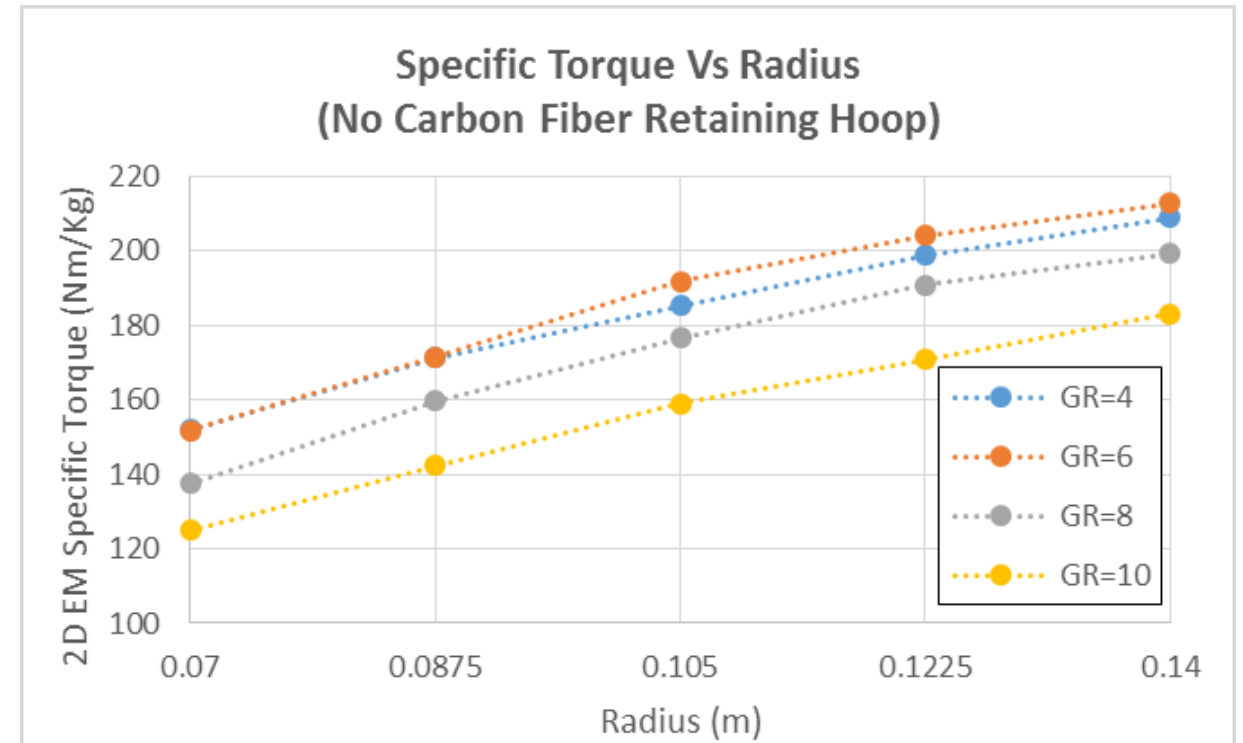

Magnetic Specific Torque Scales Linearly with Radius

# Magnetic Gear Mass

- Heavy Compared to Mechanical Gearboxes

- Active mass 2-3 x heavier with current capabilities for OH-58
- Improve by
  - Reducing Modulator Thickness
  - Reducing Airgap
  - Better Magnet Materials

OH-58 Final Planetary Stage “Active Mass”	
Sun Gear	1.02 kg
Planet Gear + Roller Bearing	1.56 kg
Ring Gear	2.26 kg
<b>Total Active Mass</b>	<b>7.96 kg</b>

OH-58 Magnetic Gear Electromagnetic Sizing Results			
Level of Tech	Mechanical Airgap	Modulator Thickness	EM Mass
NASA Current Prototype	1.00 mm	2.0 mm	21.96 kg
Improved Modulator Design	1.00 mm	1.3 mm	20.34 kg
Improved Manufacturing	0.50 mm	2.0 mm	16.43 kg
Improved Manufacturing & Design	0.50 mm	1.3 mm	12.00 kg
Highly Improved Manufacturing	0.25 mm	1.3 mm	8.67 kg

# Outline

---

- Background and Motivation
  - Concentric Magnetic Gears
- Results
  - Efficiency
  - Thermal
  - Mass
- **Future Work**
  - **Magnetically Geared Motors**
- Conclusions

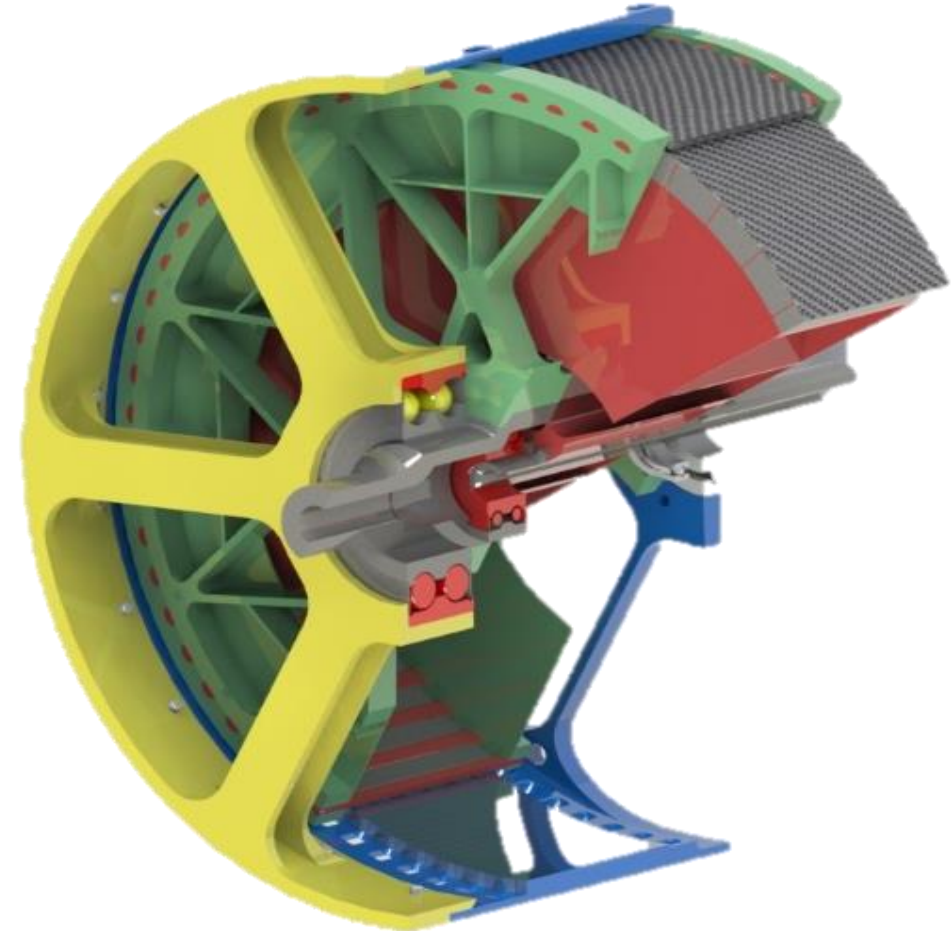

# Magnetically Geared Motors

- Share components between motor and magnetic gear
- Potential for significant mass savings
- Topologies
  1. Outer Stator
  2. Inner Stator Coupled
  3. Inner Stator Uncoupled
  4. Topologies without HS Rotor

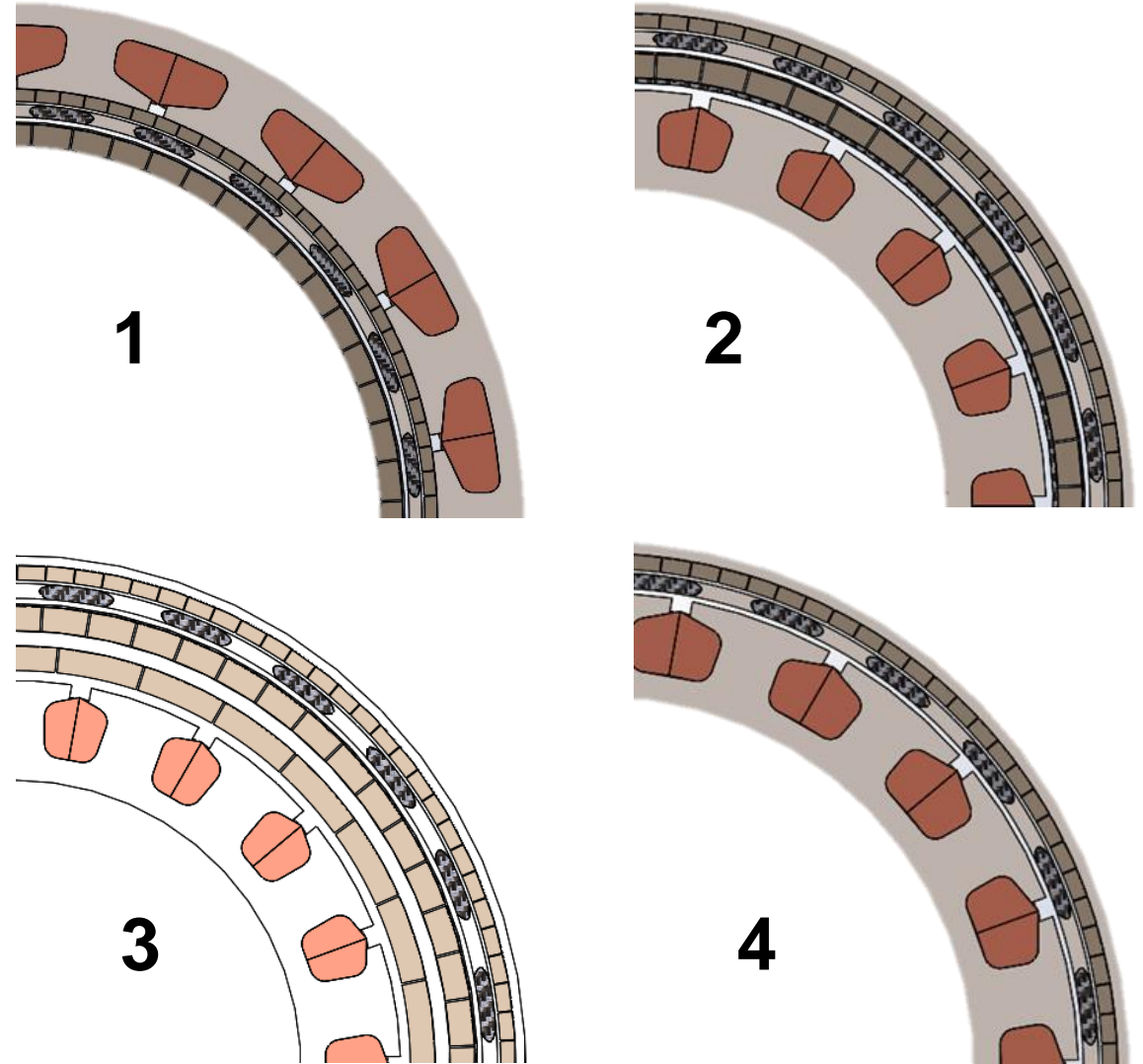

# External Stator PDD

---

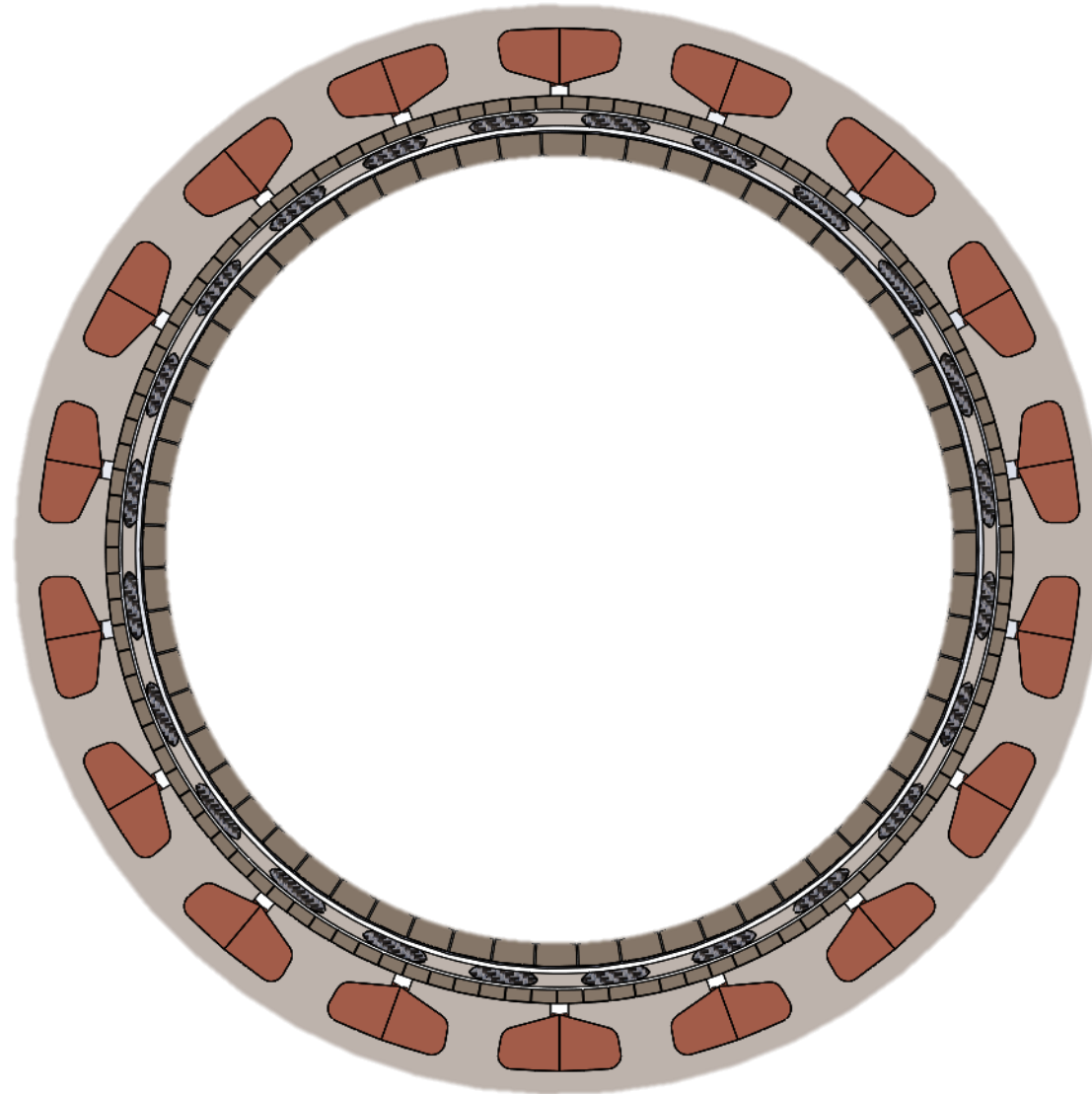

# Coupled Inner Stator PDD

---

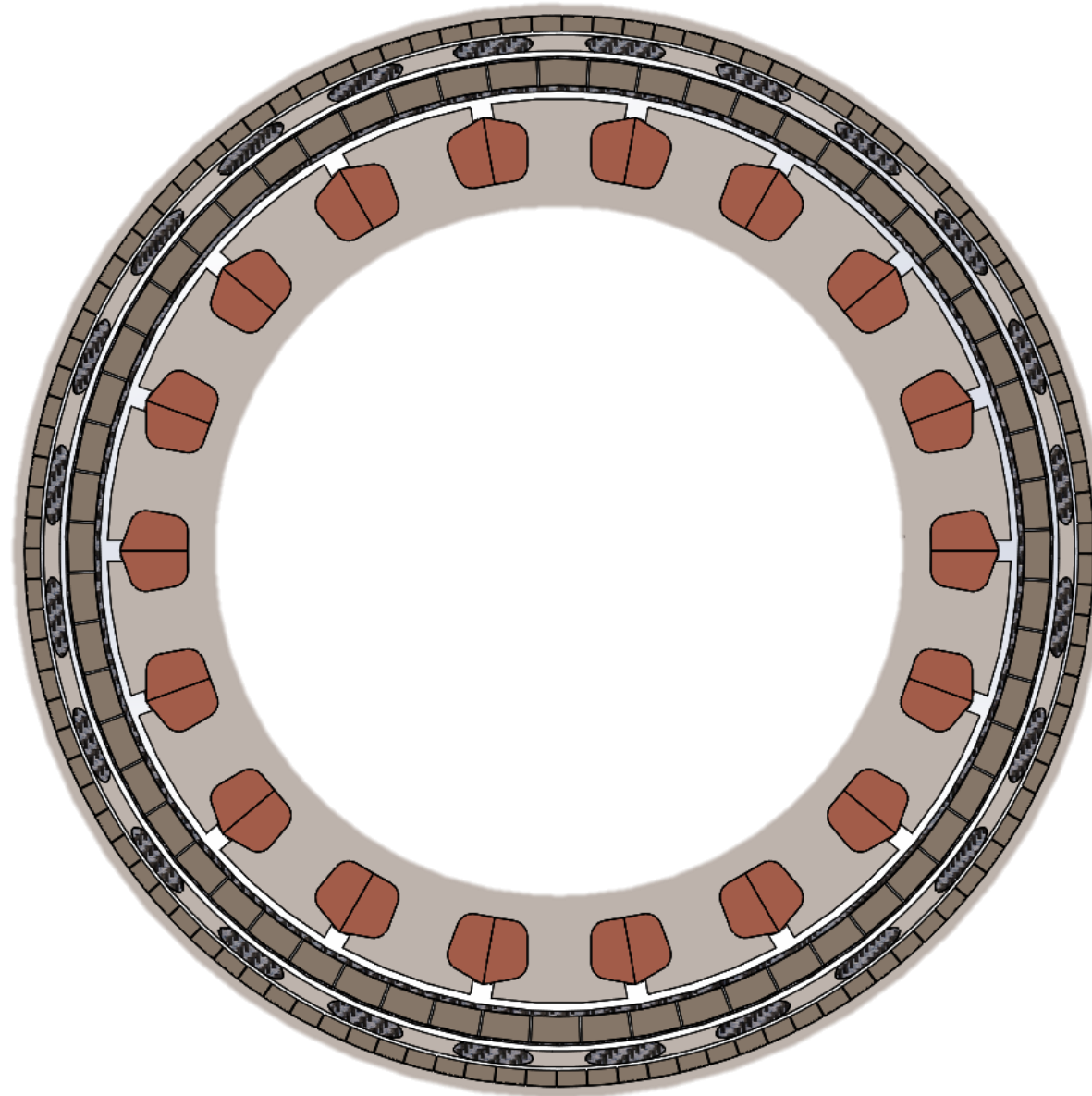

# Uncoupled Inner Stator PDD

---

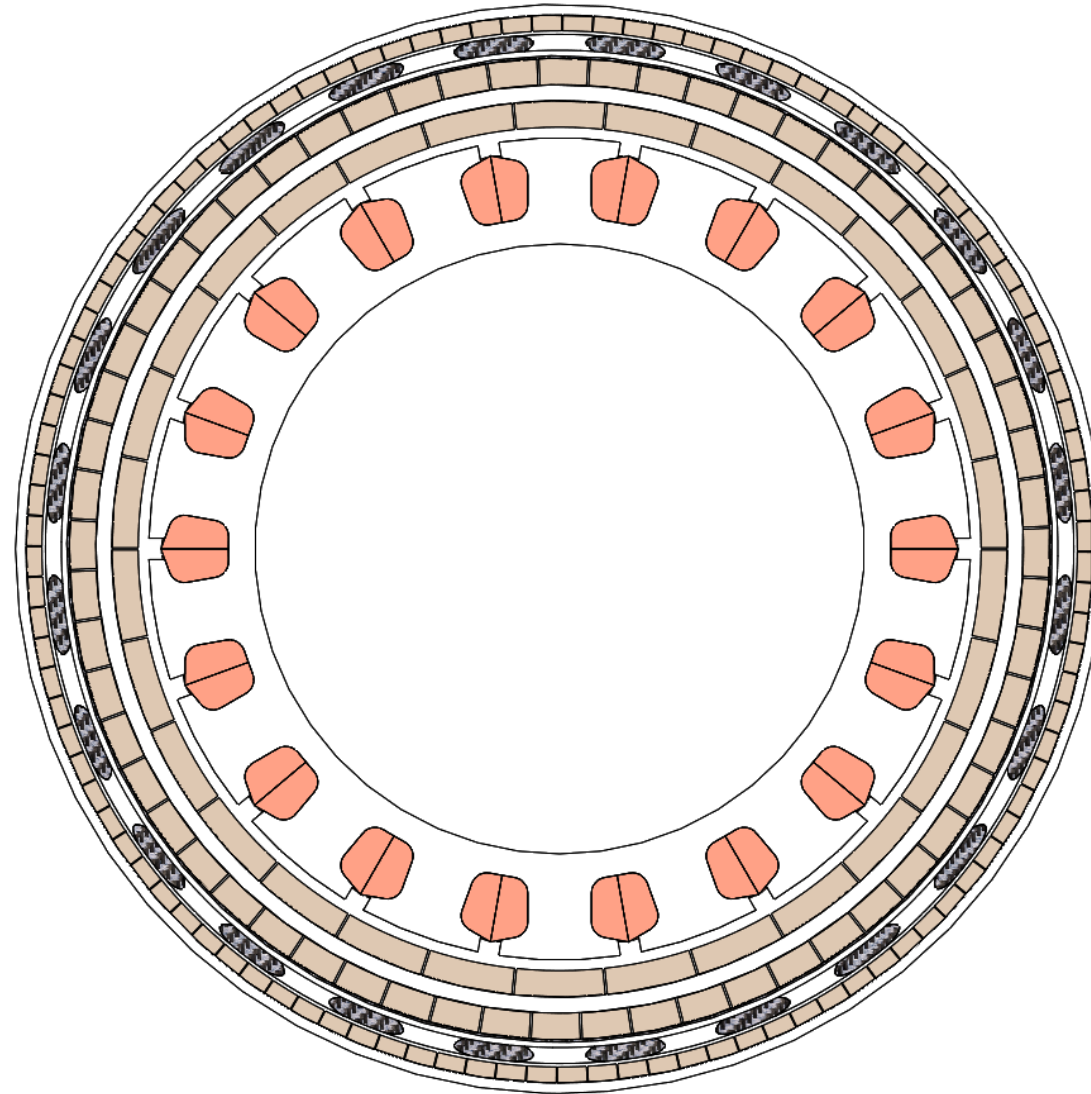

# No High Speed Rotor PDD

---

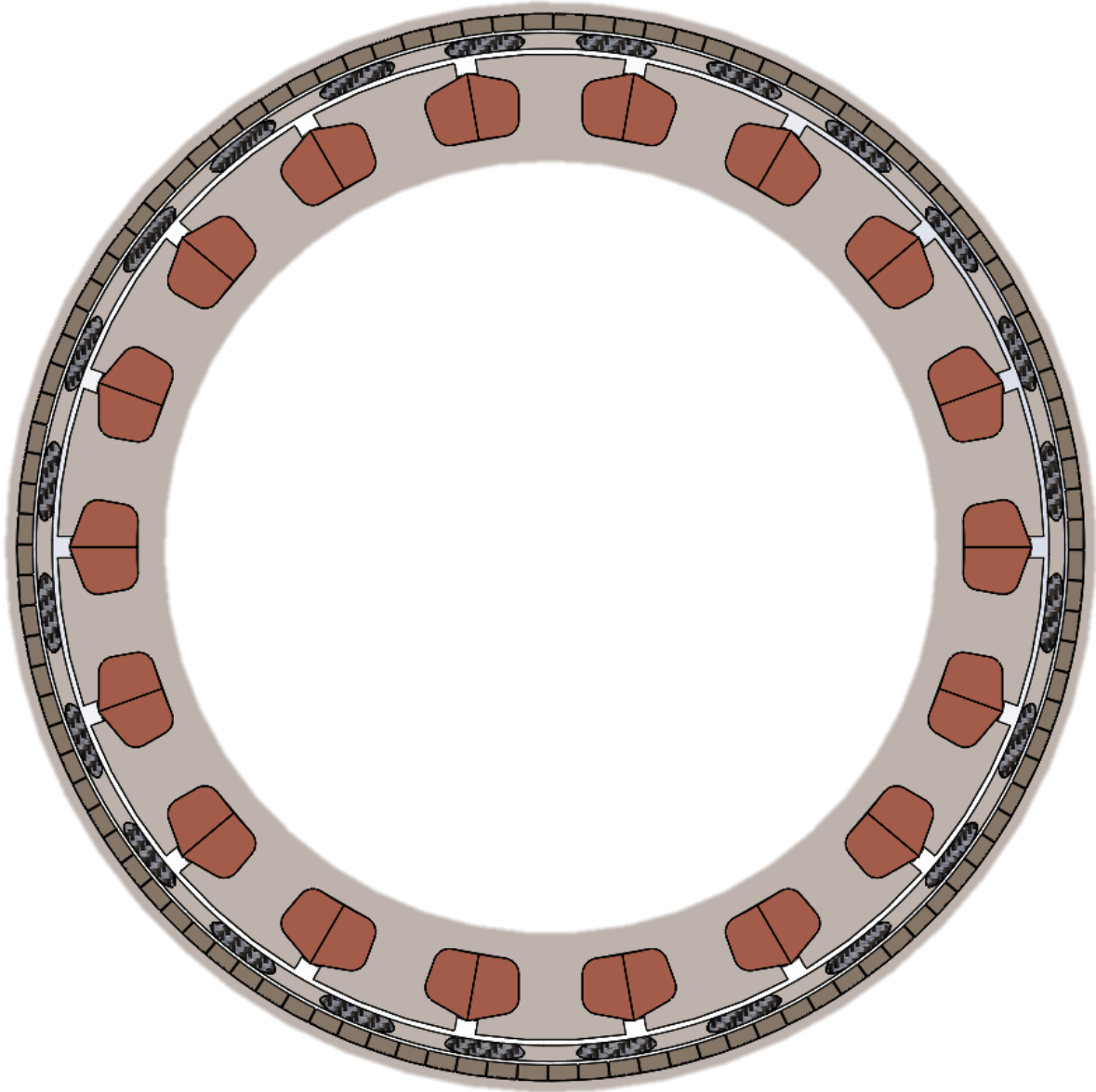

# Conclusions

---

- Magnetic gears can achieve
  1. Similar efficiency to mechanical gears
  2. Can be closed thermally with out liquid cooling
  3. Have higher mass than mechanical gear
    - » Modulator & Airgap improvements could improve mass
    - » Potential to combine with motor
  4. Potentially higher reliability than mechanical gears
    - » Needs to be demonstrated

# Acknowledgements

---

- NASA Revolutionary Vertical Lift Technology (RVLT) Project
- NASA Internal Research & Development (IRAD) Project

# QUESTIONS ?

