



## Biological CubeSats: what have we learned so far and what is next?

*Sergio R. Santa Maria, Luis Zea (CU Boulder) & Tony Ricco*





**Microgravity & space radiation**



## Microgravity effects

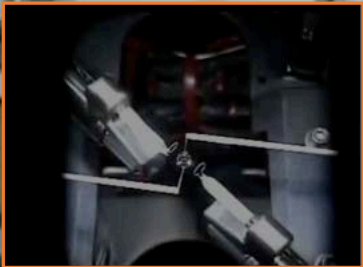

# Interplanetary space radiation

*What are we going to encounter beyond LEO?*

Solar Particle  
Events (SPEs)

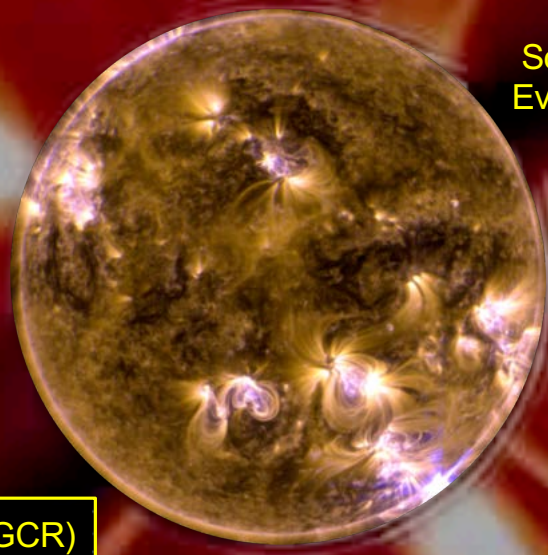

Galactic Cosmic Rays (GCR)



Solar Protons  
&  
Heavier Ions

Trapped Particles

Limits of life in space, as studied to date:

- 12.5 days on a lunar round trip &
- 1.5 years in LEO (ISS)



## Space radiation effects

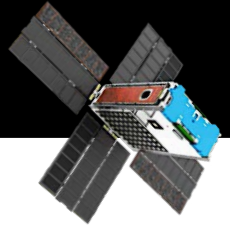

Radiation & spaceflight damages chromosomes as measured in astronauts' white blood cells (lymphocytes) – expect effect to be greater in deep space than on ISS

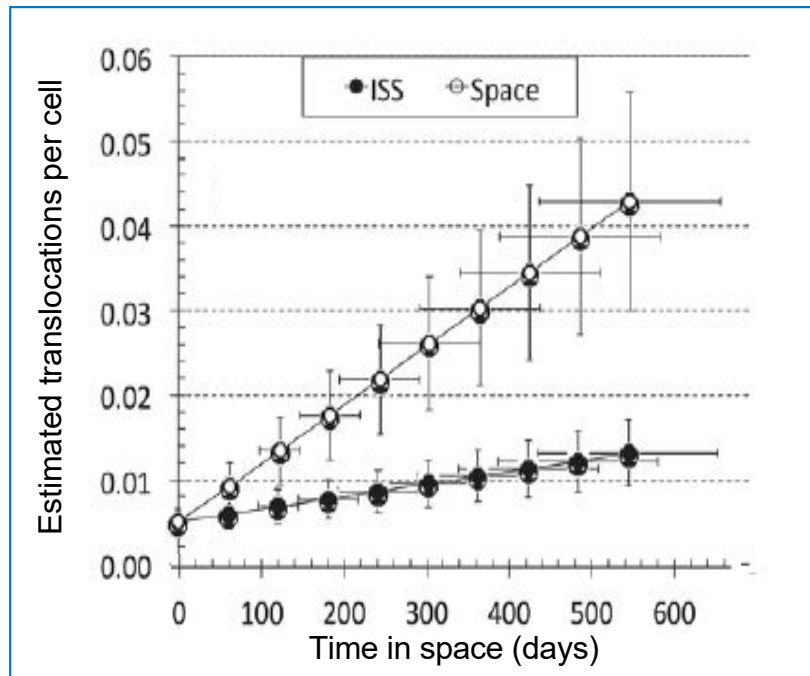

Straume et al. 2017

- Astronauts have **↑** in # chromosomal abnormalities, even at low Earth orbits, during ISS, Mir & STS (Hubble shuttle) missions
- The relative increase in frequency of these chromosomal abnormalities ranges from 1.5 to 1.8 times more than pre-flight levels (95% CL)
  - GCR will be much more abundant as astronauts go to higher orbits beyond Earth's protective magnetosphere

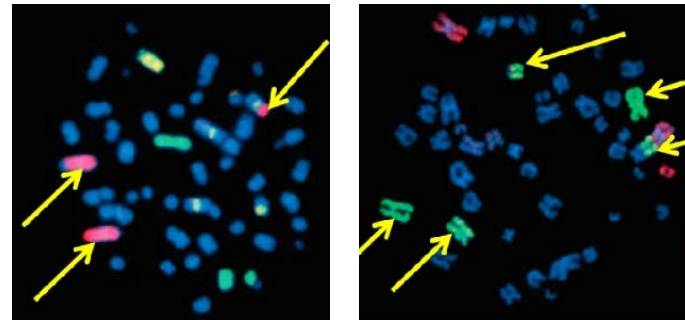

Chromosomes 1, 2, 4 in red, green, and yellow (ISS)

Cucinotta et al. 2008



**What's next for NASA?**



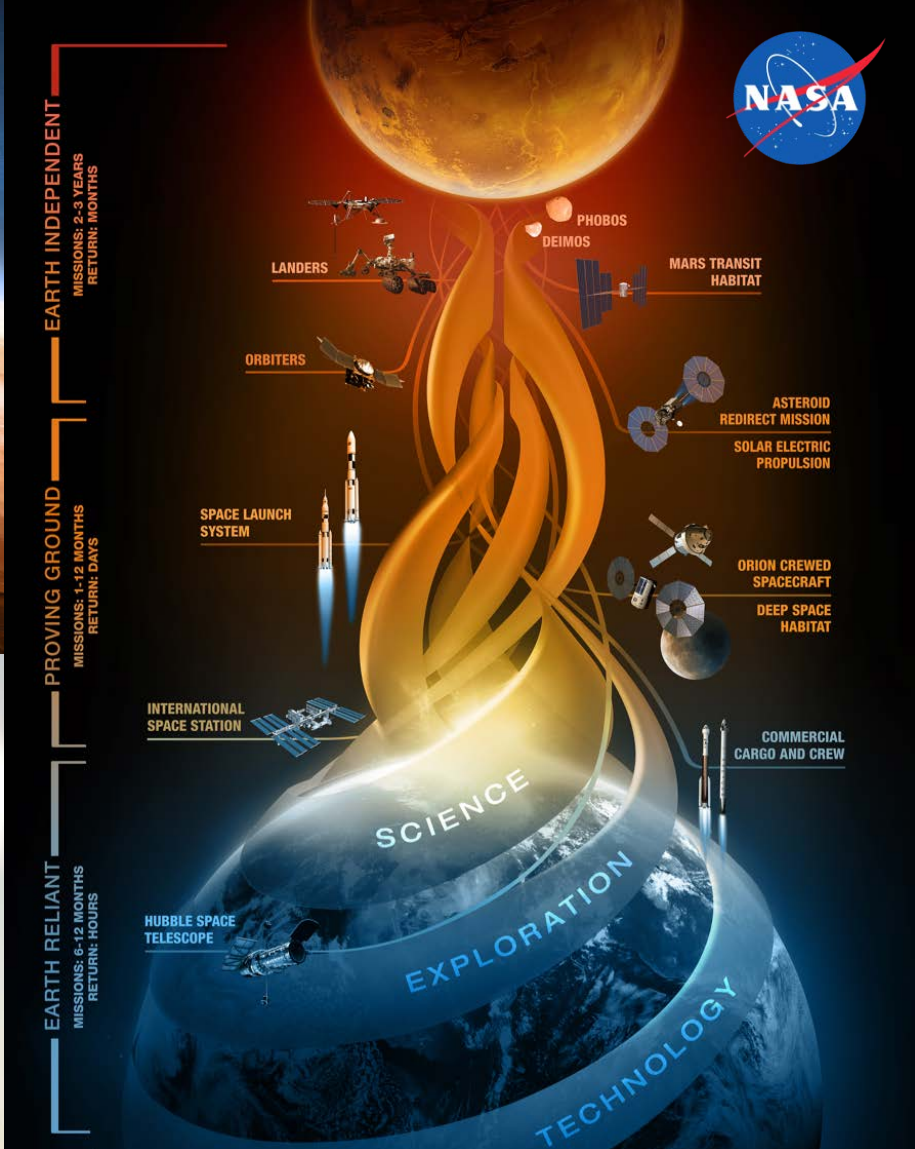



The limits of life in space – as we know it – is 12.5 days on a lunar round trip or 1.5 years in LEO. As we send people further into space, we can use model organisms to understand the biological risks and how they can be addressed.

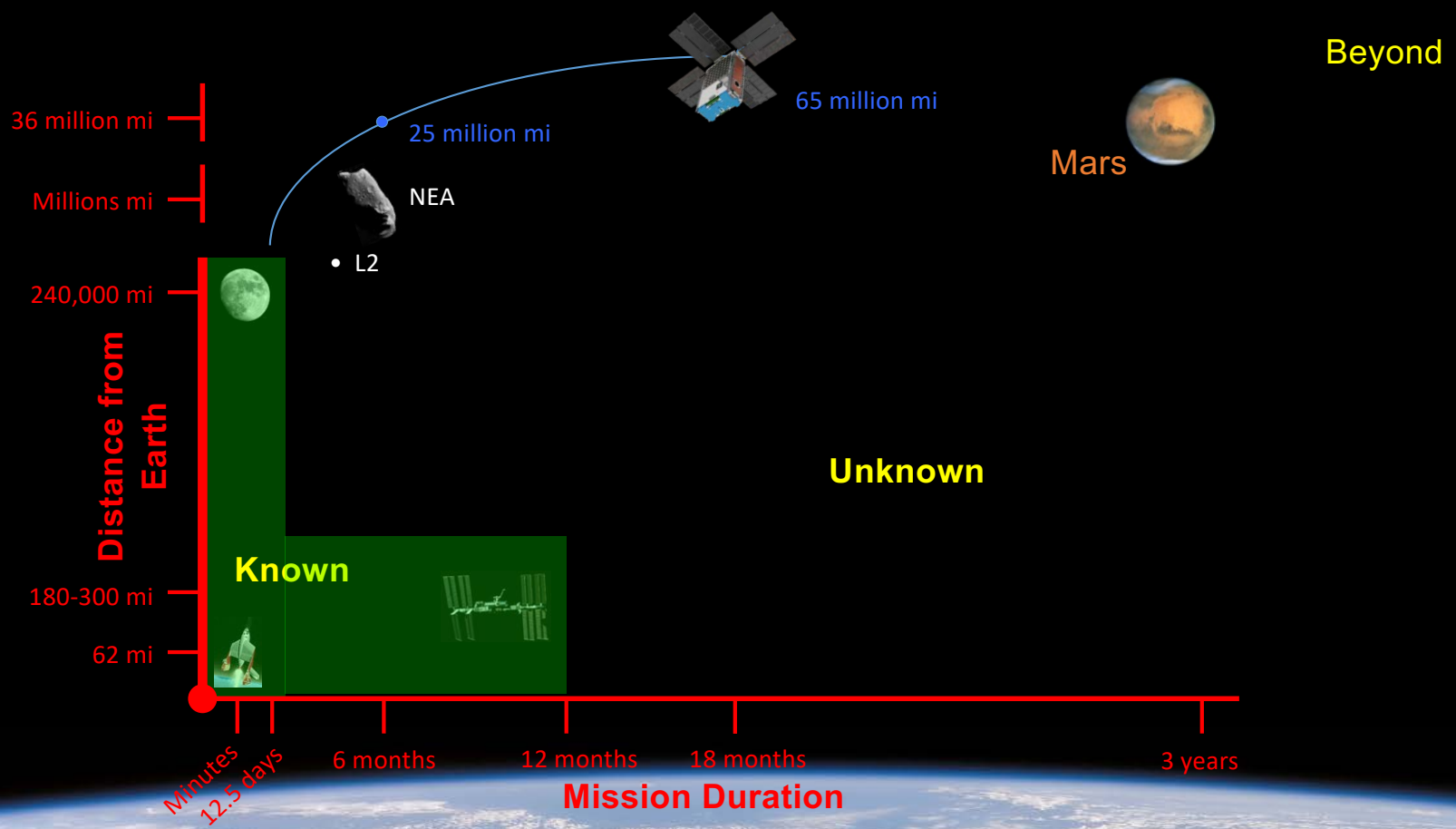



# CubeSats



# CubeSat technologies

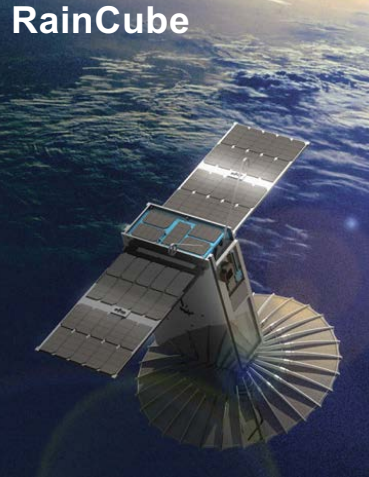
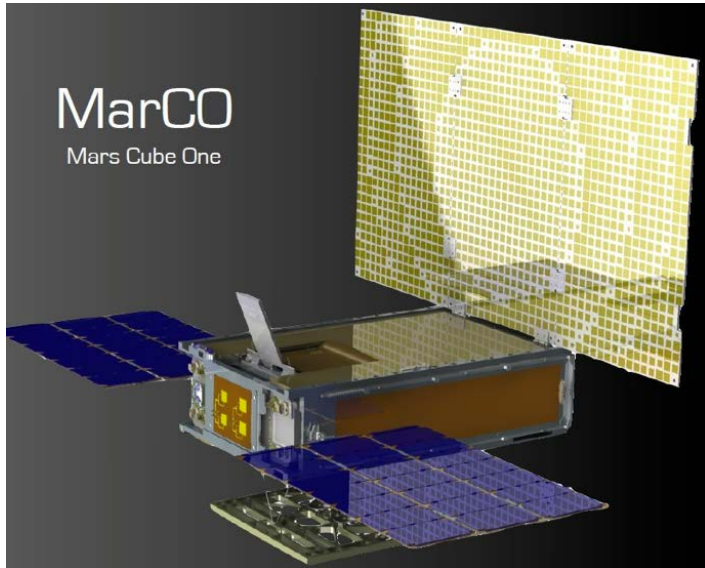

ISARA (Integrated Solar Array and Reflectarray Antenna)

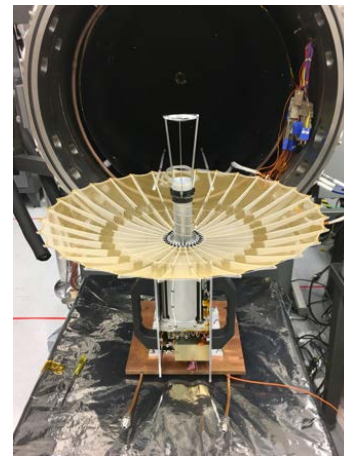
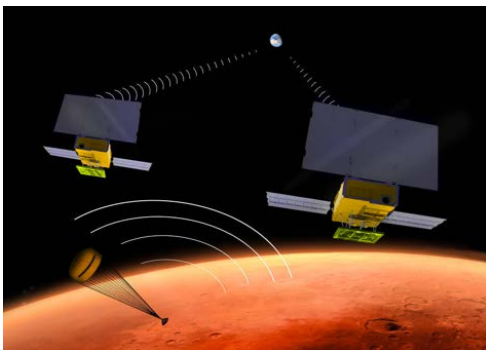
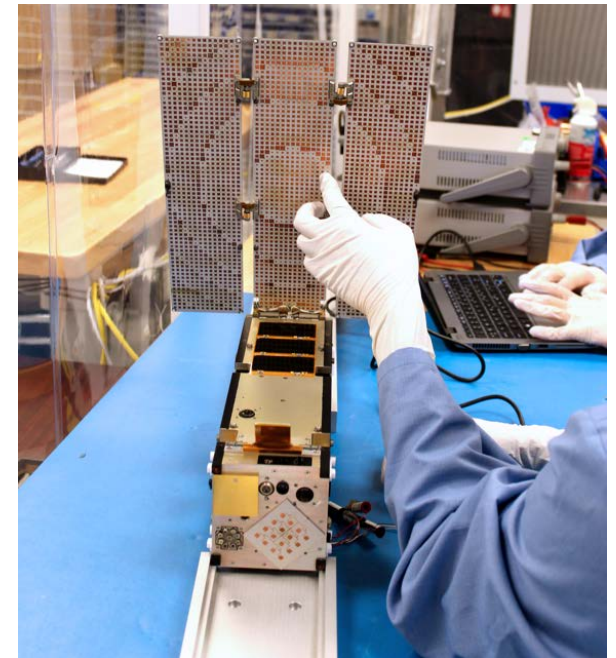



# CubeSat technologies

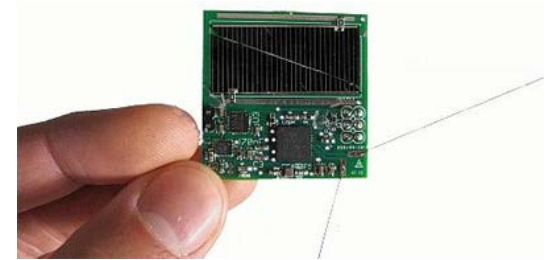



# CubeSat technologies

## EDSN (Edison Demonstration of Smallsat Networks)

### Mission Goal

To demonstrate that a swarm of satellites is capable of collecting multi-point science data and transferring the data to the ground

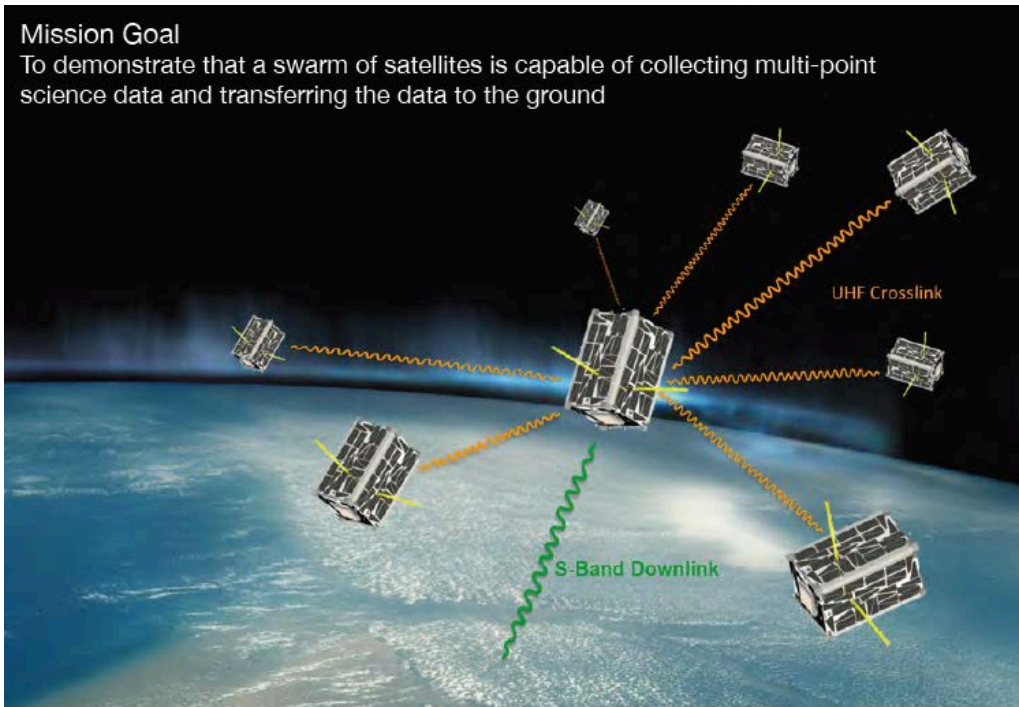

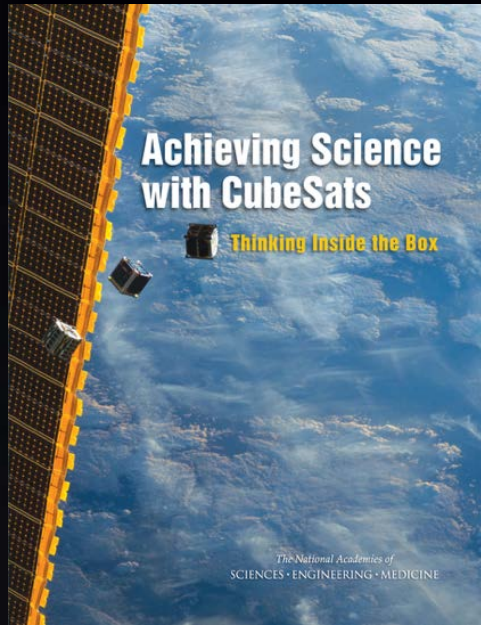

## Why Cubesats?

- Small Sats are ever more capable: technology miniaturization
- Access to space: multiple low-cost launches possible (test, learn, iterate)
- Excellent education vehicle (worldwide)
- Autonomous operations
- Technology migration: ISS; landers/orbiters for moon, Mars, other planets

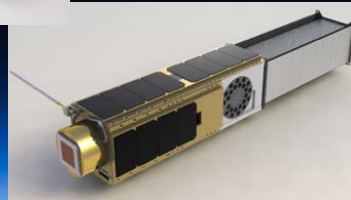
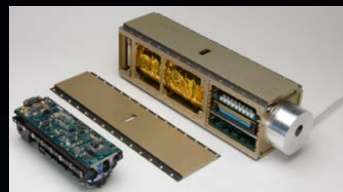

**Biological missions using CubeSats**  
(NASA Ames Research Center, 2006 – 2018)

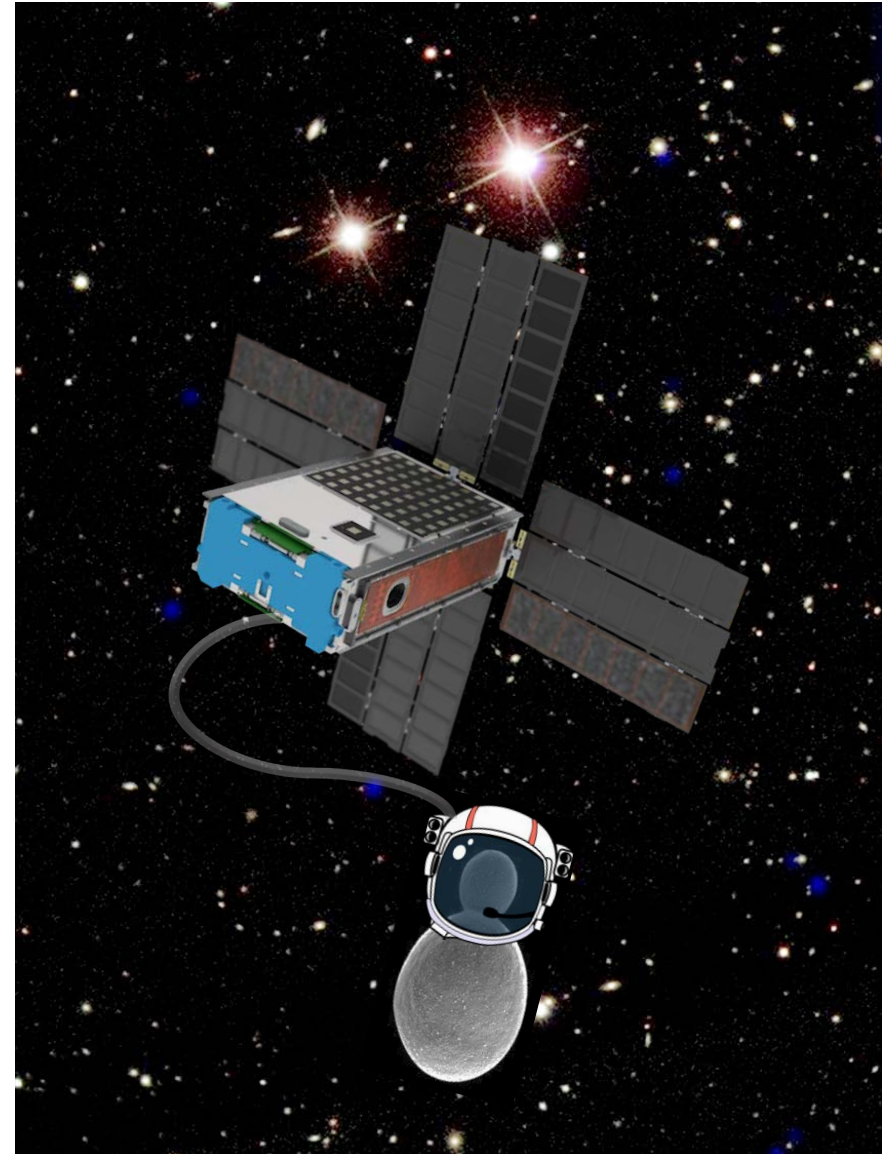



# NASA Ames pioneering biological space missions



***E. coli*** GeneSat-1 (2006 / 3U): **gene expression**  
EcAMSat (2017 / 6U): **antibiotic resistance**

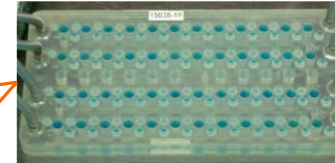

***S. cerevisiae*** PharmaSat (2009 / 3U): **drug dose response**  
BioSentinel (2019 / 6U): **DNA damage repair**

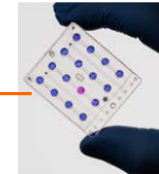

***B. subtilis*** O/OREOS\* (2010 / 3U): **survival, metabolism**  
ADRoIT-M\*\* (20xx / 6U): **mutations / lithopanspermia**

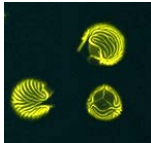
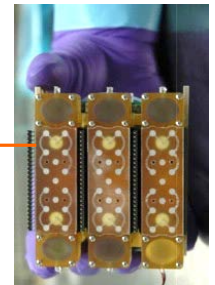

***C. richardii*** SporeSat-1 (2014 / 3U): **ion channel sensors,  $\mu$ -centrifuges**  
SporeSat-2 (2018 / 3U): **plant gravity sensing threshold**



***C. elegans*** FLAIR (20xx / 3U): **dual-wavelength fluorescence imager**

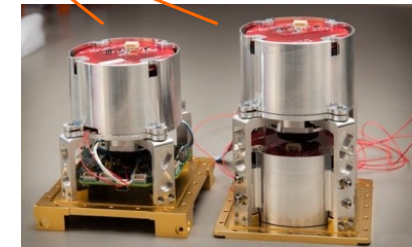
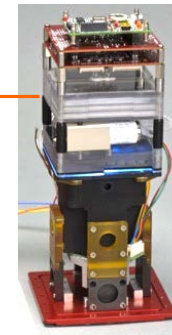

\*Organism/Organic Response to Orbital Stress

\*\*Active DNA Repair on Interplanetary Transport of Microbes





# GeneSat mission

1<sup>st</sup> biological nanosatellite in Earth's orbit, 1<sup>st</sup> real-time, *in-situ* gene expression measurement in space

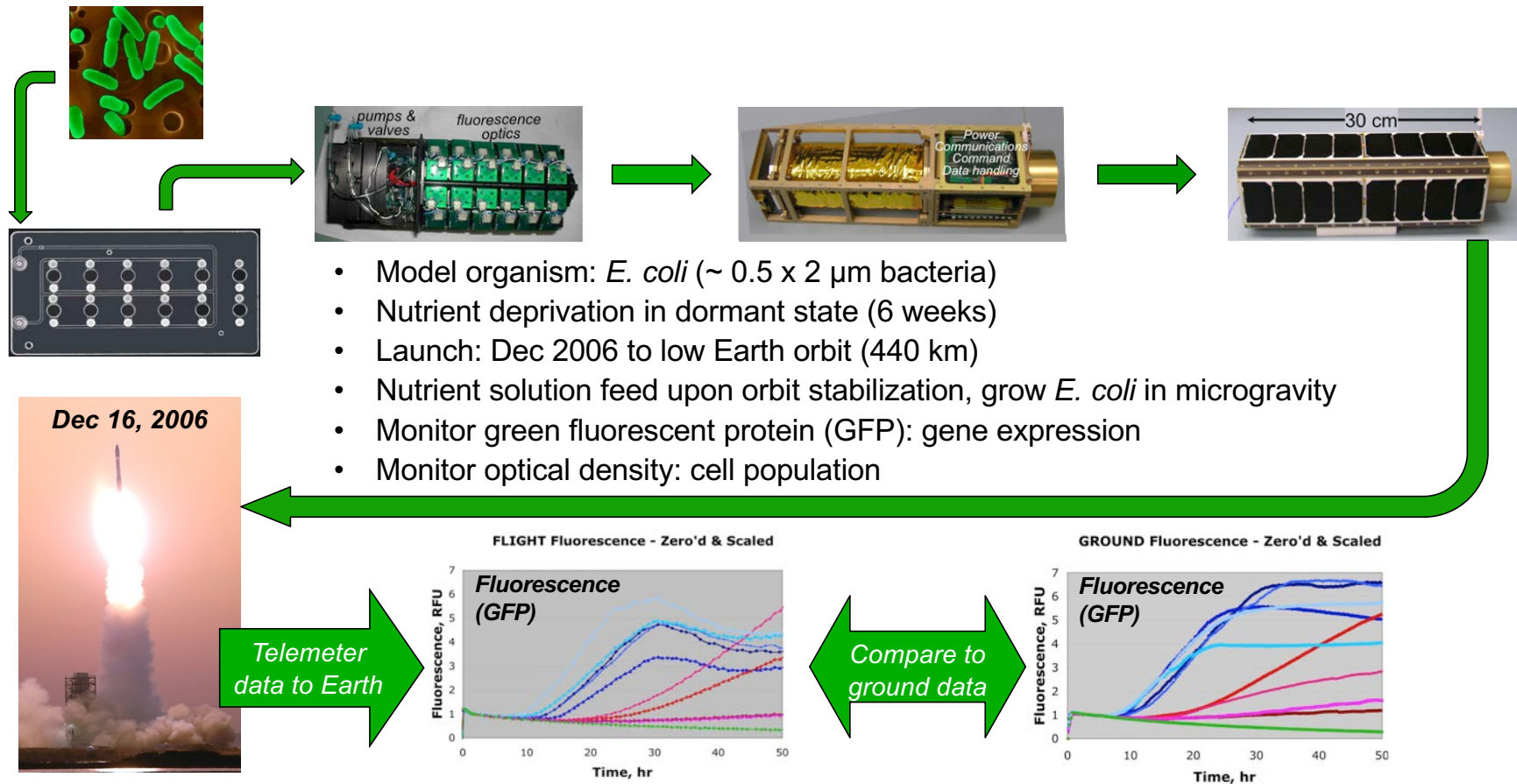



# PharmaSat mission

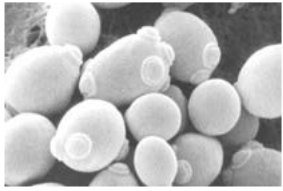

*S. cerevisiae*

## Effect of Microgravity on Yeast Susceptibility to Antifungal Drugs

- Grow yeast in multiwell fluidics card in microgravity
- Measure inhibition of growth by antifungal
- Optical absorbance (turbidity: cell density)
- Metabolism indicator dye: alamarBlue
- Control + 3 concentrations of antifungal

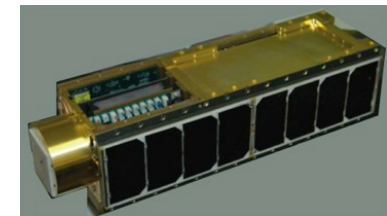
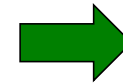
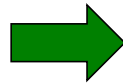
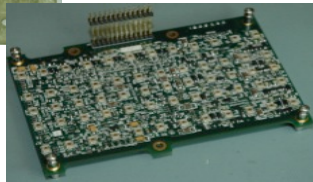

May 19, 2009



Ground

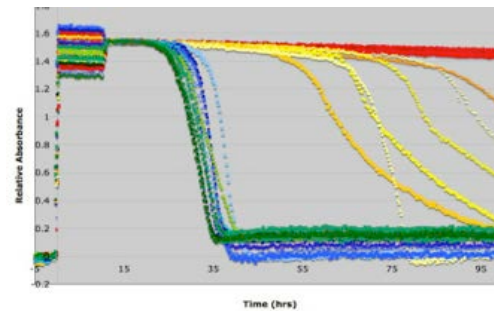

Spaceflight

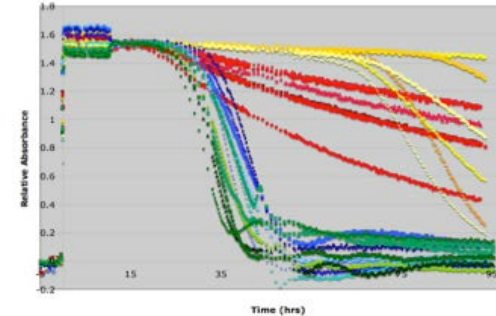



# O/OREOS mission

## Organism / Organic Response to Orbital Stress

- Effects of space exposure on biological organisms (6 mo) & organic molecules (18 mo)
- Monitor survival, growth, and metabolism of *B. subtilis* using *in-situ* optical density /colorimetry (SESLO: Space Environment Survival of Living Organisms)
- Track changes in organic molecules and biomarkers: UV / visible / NIR spectroscopy (SEVO: Space Environment Viability of Organics)

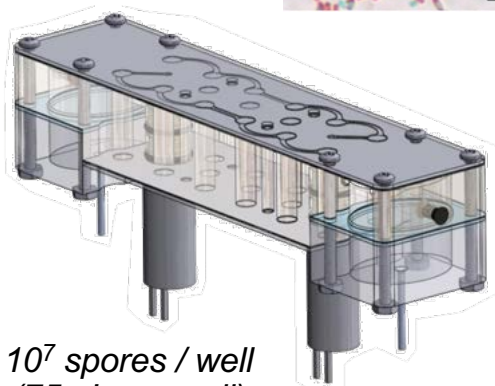

10<sup>7</sup> spores / well  
(75 µL per well)

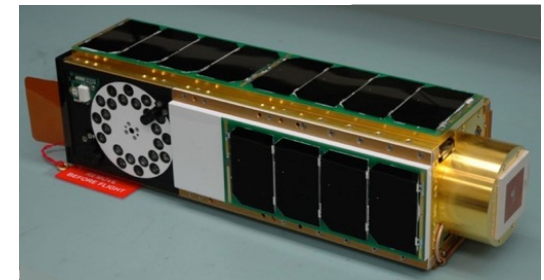
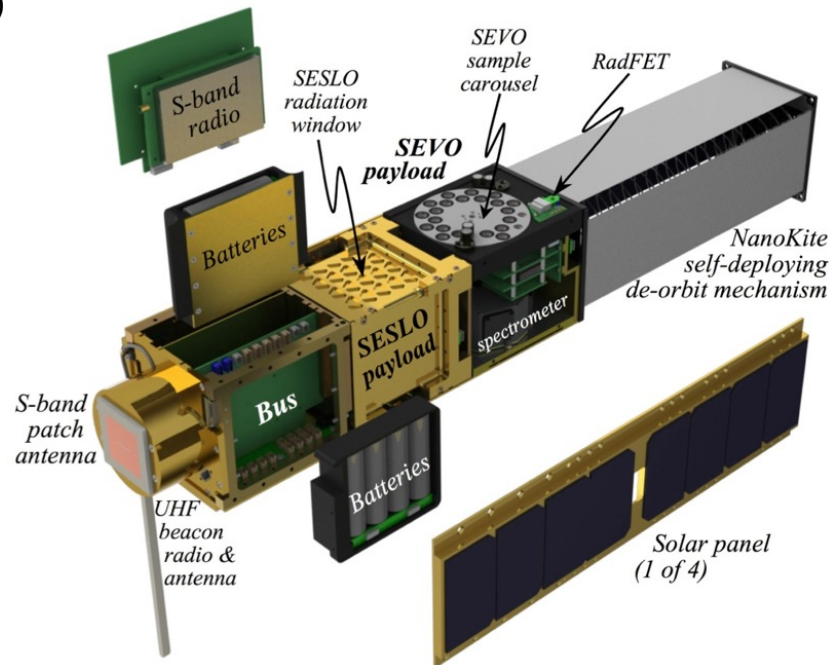



# EcAMSat mission



## *E. coli* AntiMicrobial Satellite mission

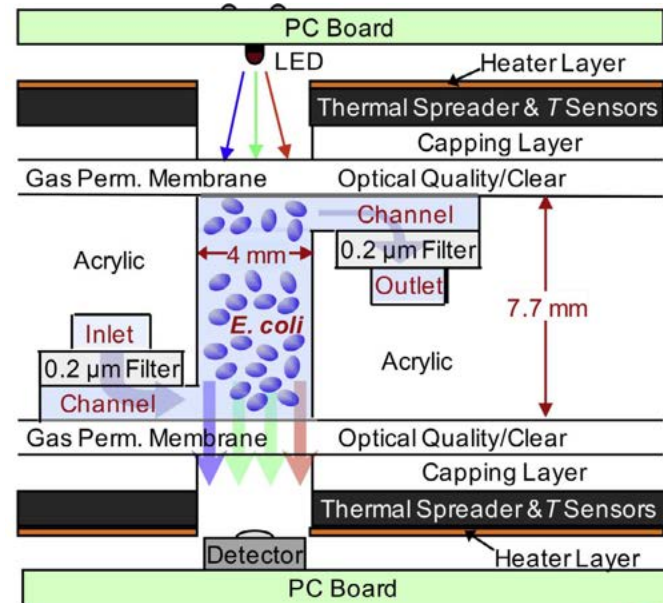
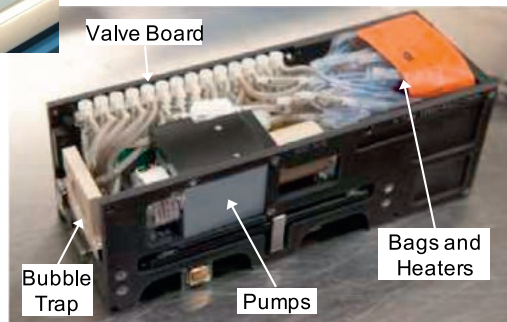
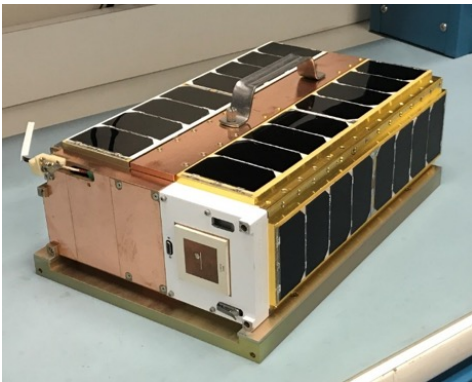



# Artemis-1 mission & BioSentinel

*(launch Nov 2020)*

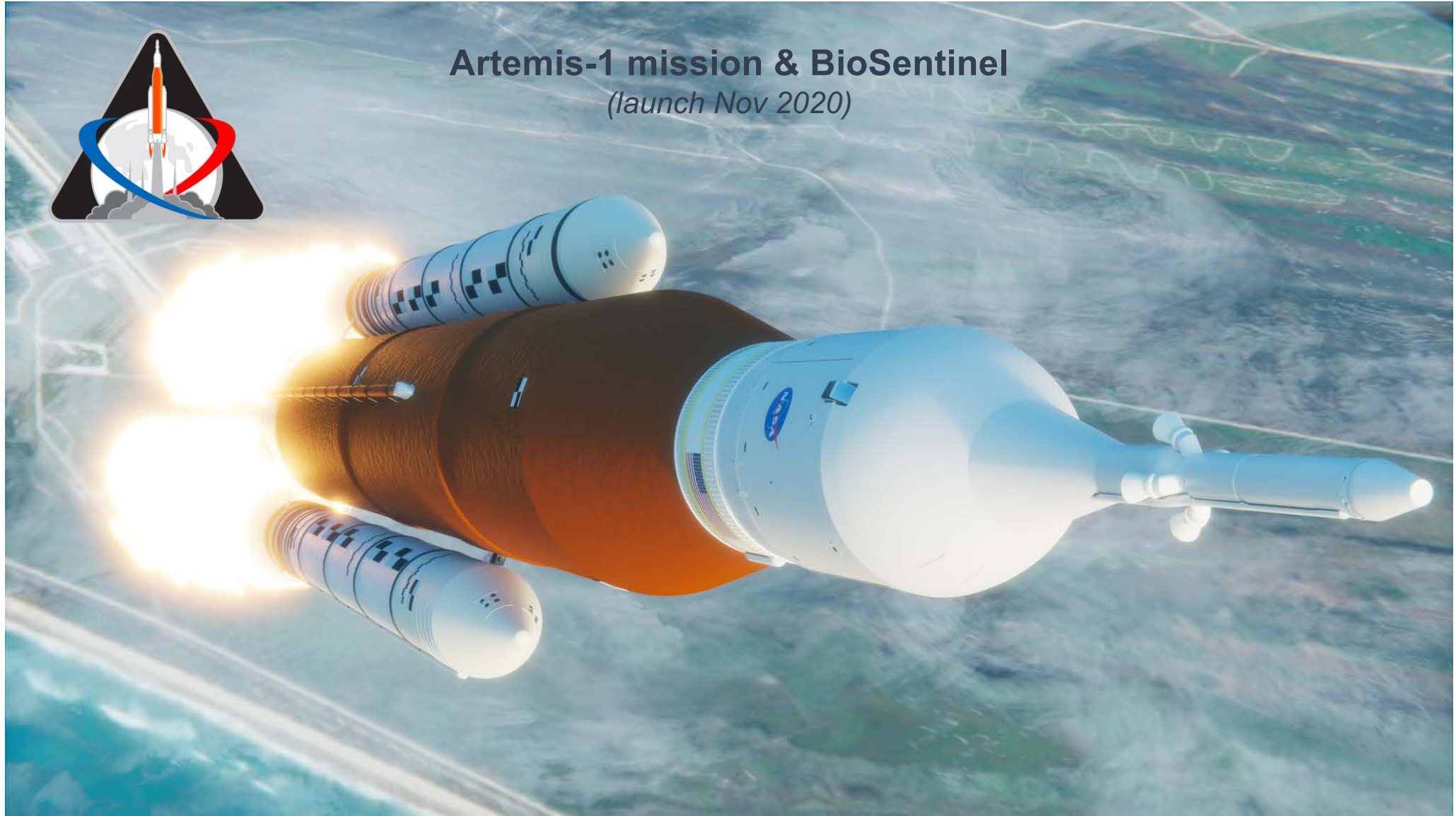



## BioSentinel mission

**Main objective:** develop a tool with autonomous life support technologies to study the biological effects of the space radiation environment at different orbits

- First biological study beyond low Earth orbit (LEO) in almost 50 years
  - First biological 6U CubeSat to fly beyond LEO
  - First CubeSat to combine biological studies with autonomous capability & physical dosimetry beyond LEO
  - Secondary payload in SLS ARTEMIS-1 (launch in Nov 2020) – currently 13 payloads
  - Far beyond the protection of Earth's magnetosphere (~0.3 AU from Earth at 6 months; ~40 million km)
  - BioSentinel will allow to compare different radiation and gravitational environments (free space, ISS...)

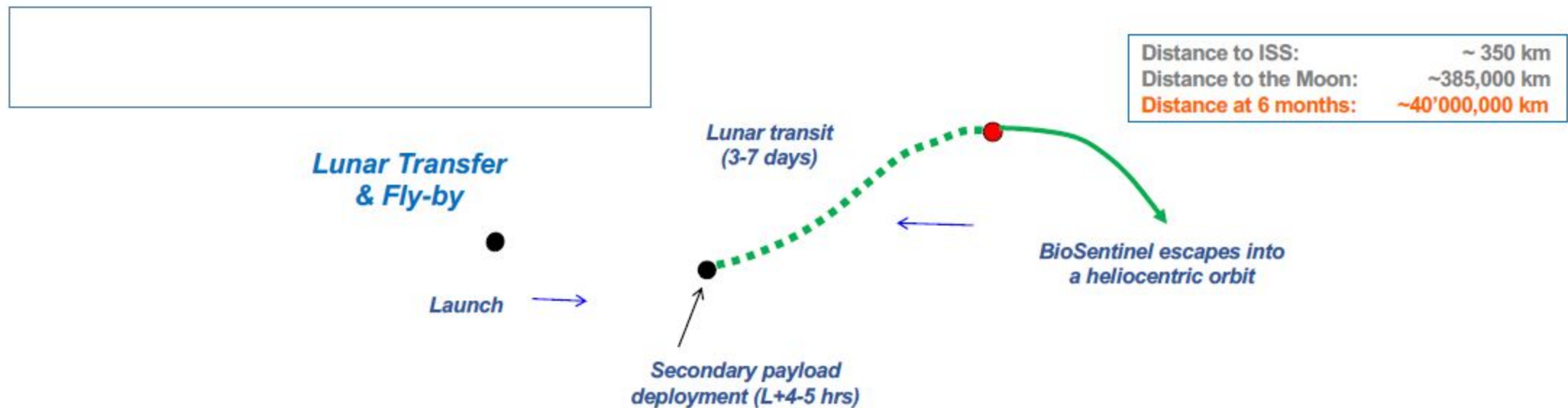



## BioSentinel: a 6U nanosatellite for deep space

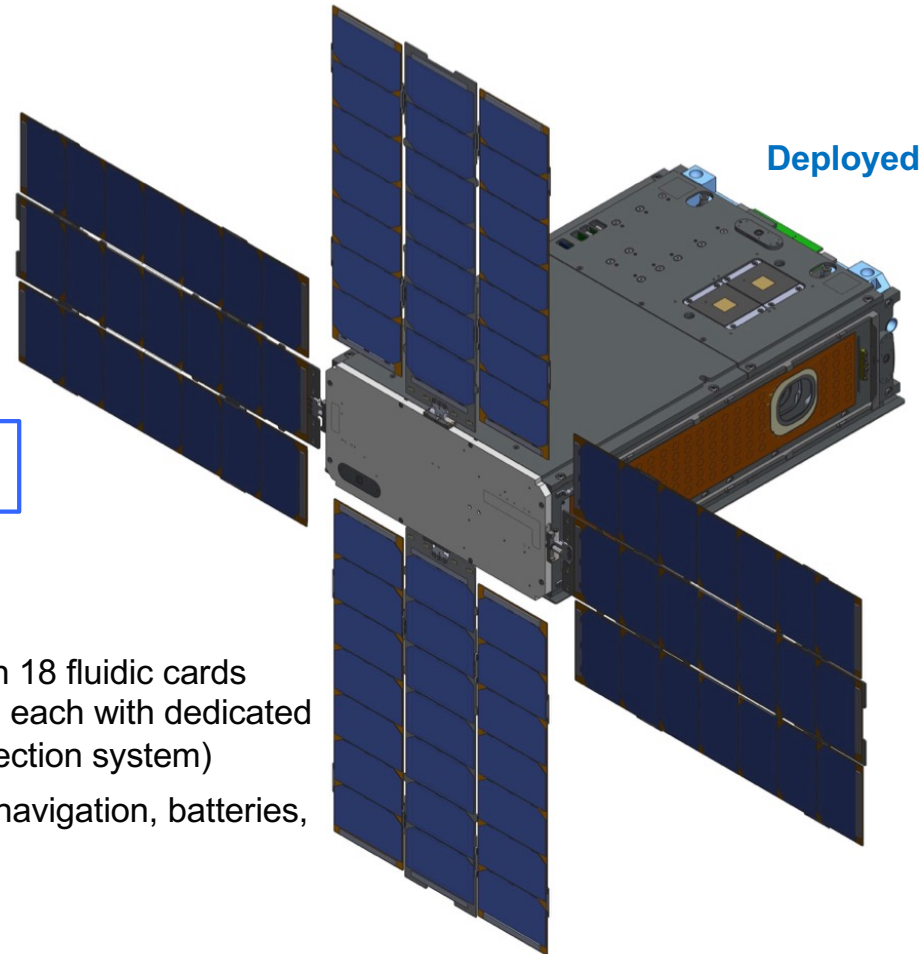

**6U CubeSat**  
37 x 24 x 12 cm ~ 10 L

### Spacecraft sections:

- BioSensor payload (~4U with 18 fluidic cards loaded with desiccated cells, each with dedicated thermal control & optical detection system)
- Spacecraft bus (propulsion, navigation, batteries, transponder, star tracker...)

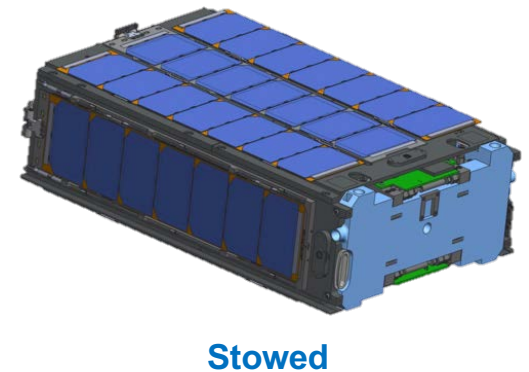



# BioSentinel: a 6U nanosatellite for deep space

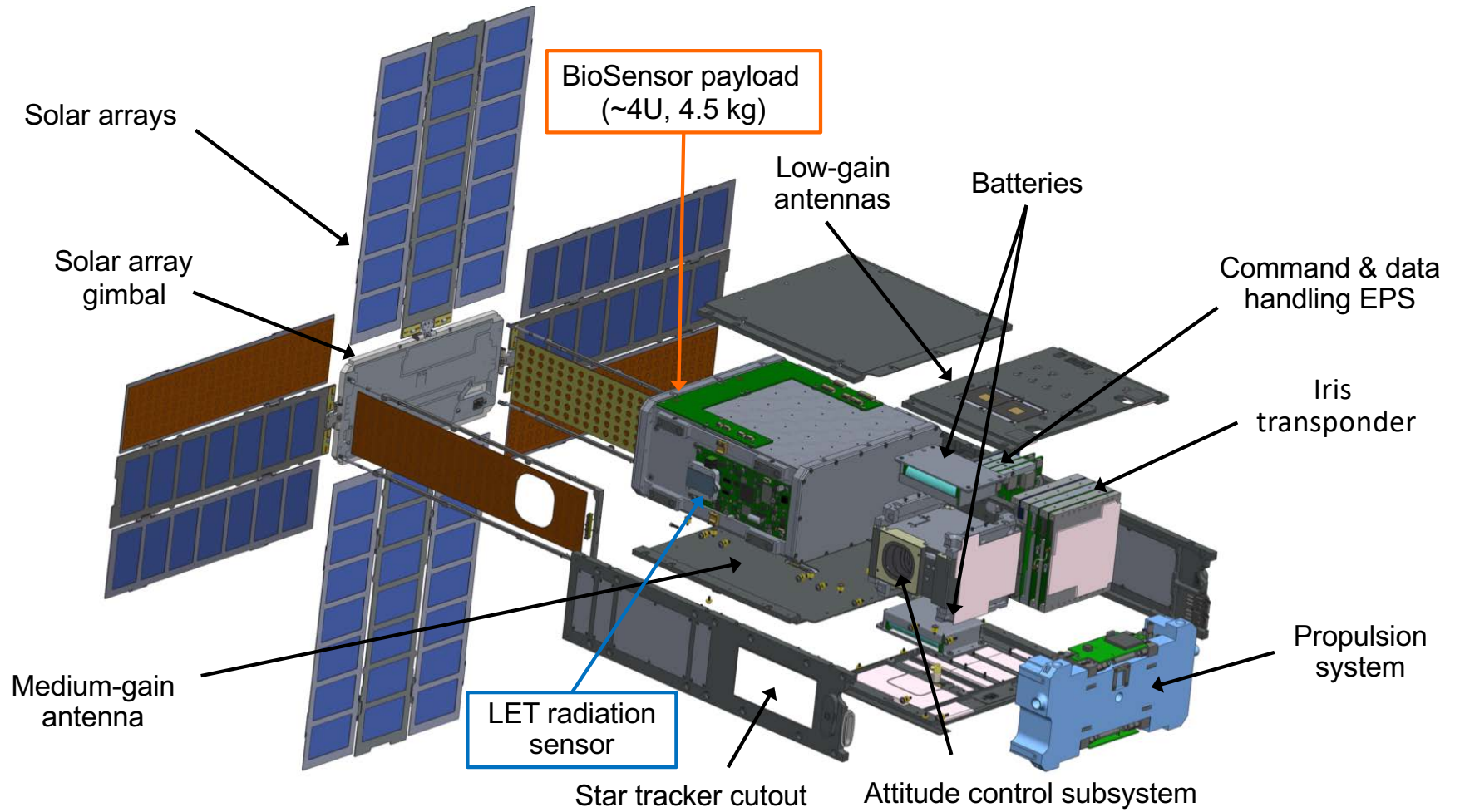





# BioSentinel: microfluidic system

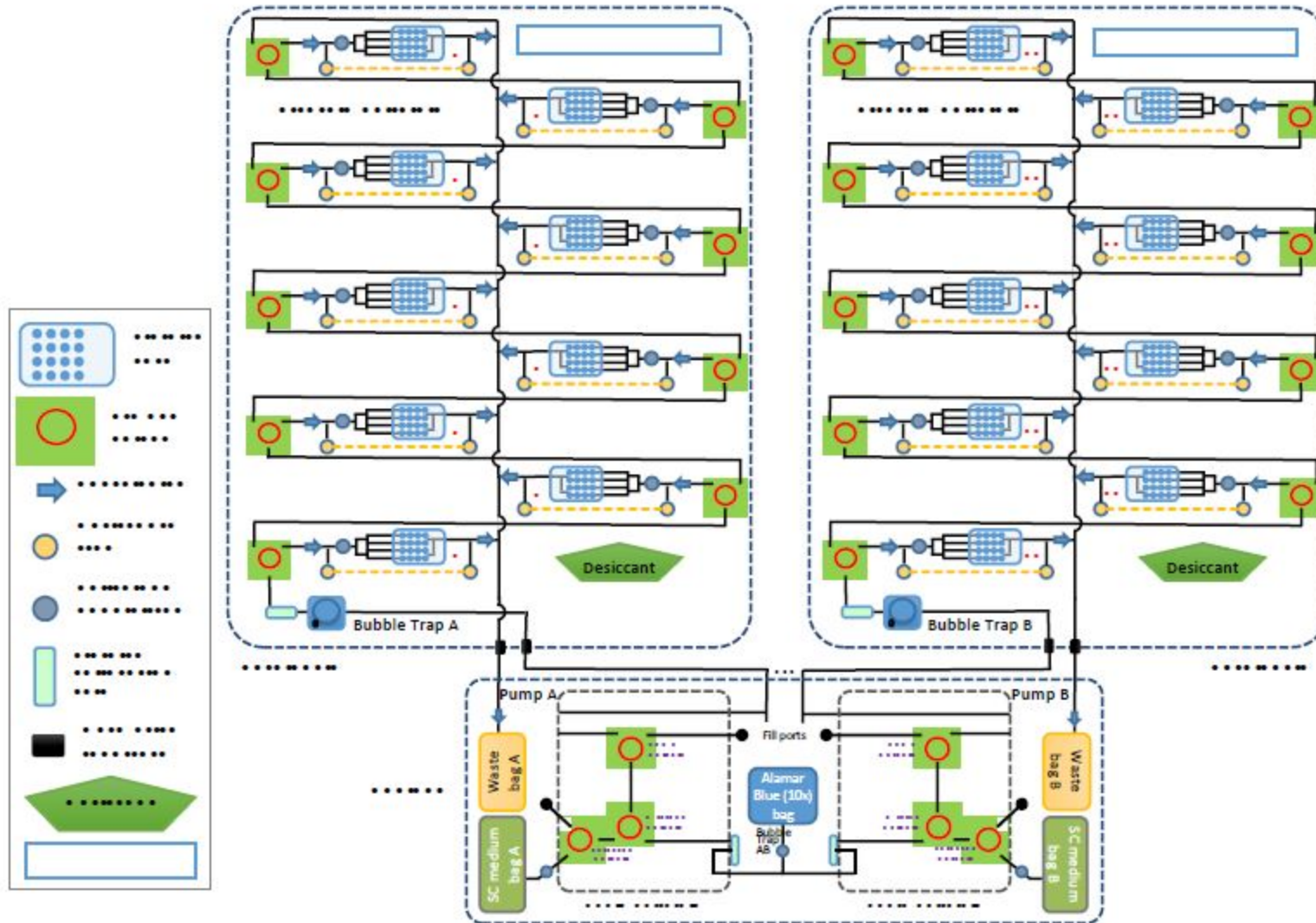

- Manifold-integrated components:*
- 2 pumps
  - 24 active & 38 check valves
  - 2 main bubble traps
  - 18 desiccant traps
  - 4 optical calibration cells
  - 18 fluidic cards with 18 small bubble traps
  - 288 microwells total



# BioSentinel: microfluidic card

Microfluidic card (x18)

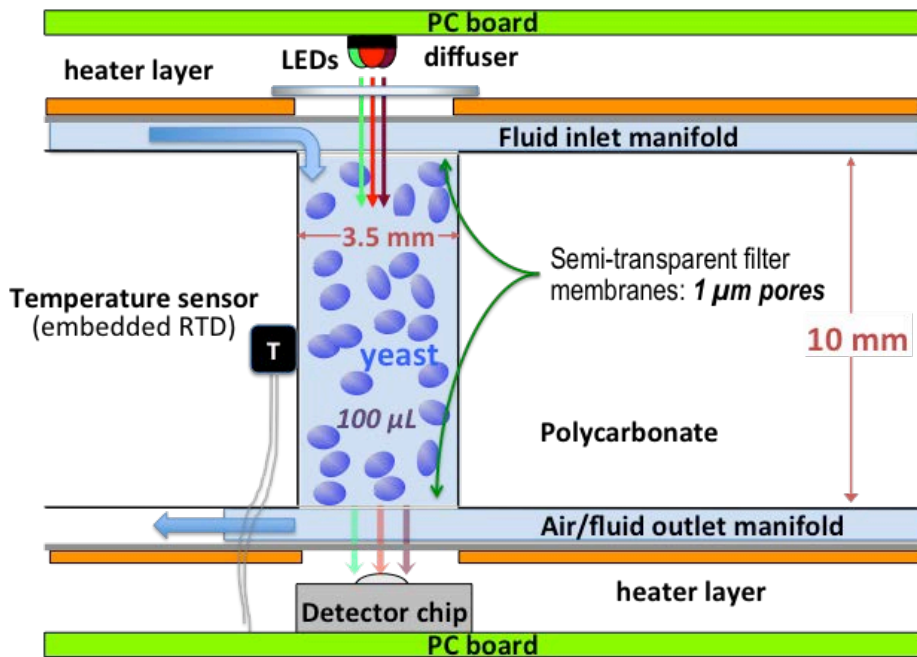
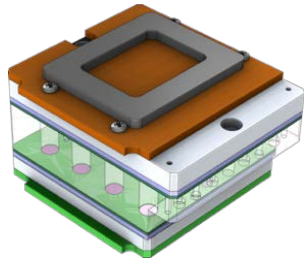

3-LED emitter

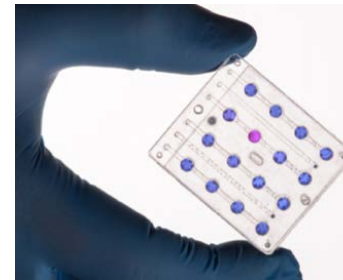
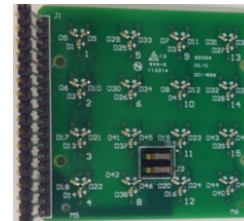

Photodiode detector array

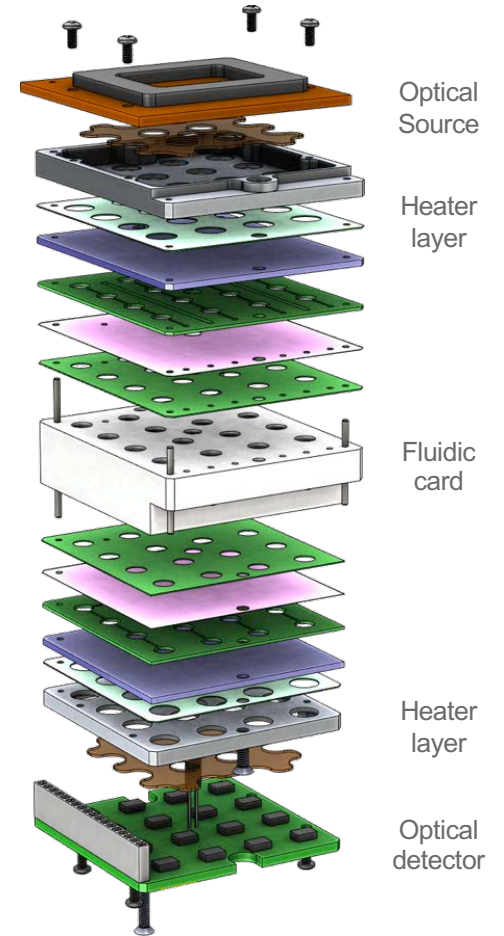
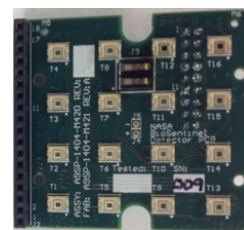



## Conclusions

- **Nanosatellites / CubeSats can do real science in LEO and in interplanetary space**
  - Tools / devices / methods of bio / micro / nano technologies are enablers
  - Real-time, *in-situ* experiments provide insights on dynamics not available from expose-and-return strategies
- **Heritage of astrobiology and fundamental space biology experiments in LEO is a major enabler for interplanetary biological missions**
  - Flying biology dry, filling fluidic microwells in microgravity
  - Long-term materials biocompatibility, stasis > 1 year, yeast in microgravity
  - Radiation-tolerant design (*e.g.*, O/OREOS functional after > 4 years)
  - High-heritage sensors, fluidic components & approach, optical measurement approach to growth & metabolism



## Future (and ongoing) objectives

A flexible design that can (and will be) used on different space platforms

