

2019 WSSCI Fall Technical Meeting
Organized by the Western States Section of the Combustion Institute
October 14–15, 2019
Albuquerque, New Mexico

Infrared Measurements of Forward Heat Conduction during Simulated Microgravity Flame Spread in the Narrow Channel Apparatus

Michael Berry¹, Dr. Fletcher Miller^{1}, Dr. Sandra Olson², Dr. Indrek Wichman³*

¹*Department of Mechanical Engineering, San Diego State University, San Diego, CA 92182-1323, USA.*

²*NASA Glenn Research Center at Lewis Field, Cleveland, OH 44135, USA.*

³*Department of Mechanical Engineering, Energy and Automotive Research Laboratories, Michigan State University, East Lansing, MI 48824-1226, USA.*

**Corresponding Author Email: fmiller@sdsu.edu*

Abstract: An infrared (IR) camera provides a way of examining temperature trends associated with simulated microgravity flame spread in the Narrow Channel Apparatus (NCA). The IR camera measures the surface temperature of solid poly methyl methacrylate (PMMA) fuel. These tests examine the forward conduction of heat ahead of the flame front in the non-thermally thin fuel.

The NCA is a combustion wind tunnel that simulates a microgravity flame spread environment by employing a narrow gap between the fuel and ceiling of the device, limiting the effects of buoyancy. Test conditions of a 5 mm gap, mean opposed flow velocity of 15 cm/s, and fuel thickness of 3 mm are used.

PMMA is selected as the fuel due to repeatability of test results, ease of computational modeling, and known combustion mechanics. Using specific lens and bandpass filter combinations the PMMA can be imaged as effectively opaque. The spectral emissivity for PMMA was calculated and incorporated into the calibration of the camera.

Surface temperatures from the IR camera are compared to results from thermocouples embedded in the surface of the fuel. The IR camera results show that nontrivial forward conduction occurs during tests, and therefore must be included in computational models of the process.

Keywords: *Simulated microgravity combustion, Infrared imaging, Narrow Channel Apparatus, PMMA Combustion, Solid Fuel Combustion*

1. Introduction

Study of flame spread in microgravity environments is a vital and challenging component of spacecraft fire safety planning. True, long-duration microgravity combustion testing environments are effectively limited to the International Space Station's Microgravity Sciences

Glovebox (MSG), or the Combustion Integrated Rack (CIR)¹. Both options have provided important data but are prohibitively expensive. Other test environments, such as drop towers or aircraft, are limited to thermally thin fuels due to the very short microgravity time available. Thus, an alternative ground-based approach to microgravity flame spread testing is needed. San Diego State’s Narrow Channel Apparatus (NCA) simulates a microgravity flame spread and spacecraft atmosphere environment. The NCA is a horizontal opposed flow combustion channel that can simulate a microgravity environment primarily through buoyancy suppression. This environment is achieved by limiting the gap between the fuel and window (see Figure 1), limiting flame elongation in the vertical direction. Buoyancy is one of the key differences between flame spread on Earth, with the full effects of gravity, and a microgravity environment.

The flame spread in the NCA has been simulated with computational modeling for both one-dimensional and two-dimensional solid-phase heat conduction cases of thermally thick polymethyl methacrylate (PMMA) [1]. The two-dimensional case has been modeled with Fire Dynamics Simulator coupled with Gpyro. The two-dimensional model shows similar flame spread behavior to actual testing in the NCA when compared to the one-dimensional case. It is, however, much more computationally expensive than the one-dimensional case. For this reason, measurements of forward conduction from testing in the NCA are needed to further justify the use of the two-dimensional model, as well as to verify that the computations are capturing the physics correctly.

A schematic of flame spread in the NCA is shown in Figure 1. Key physical features include: the gap height, set to minimize buoyancy contributions and heat losses to the ceiling, the horizontal opposed flow configuration, and the thick PMMA sample itself. Processes of note are a heat flux from the flame to the sample surface, conduction into the sample surface (shown as $q_{rad} + q_{cond}$ and modeled as one-dimensional solid phase conduction), and forward heat conduction ahead of the flame (shown as q_{cond} and the pre-heat zone). While forward heat conduction represents a small portion of this schematic, this paper will present results that indicate a substantial pre-heating region.

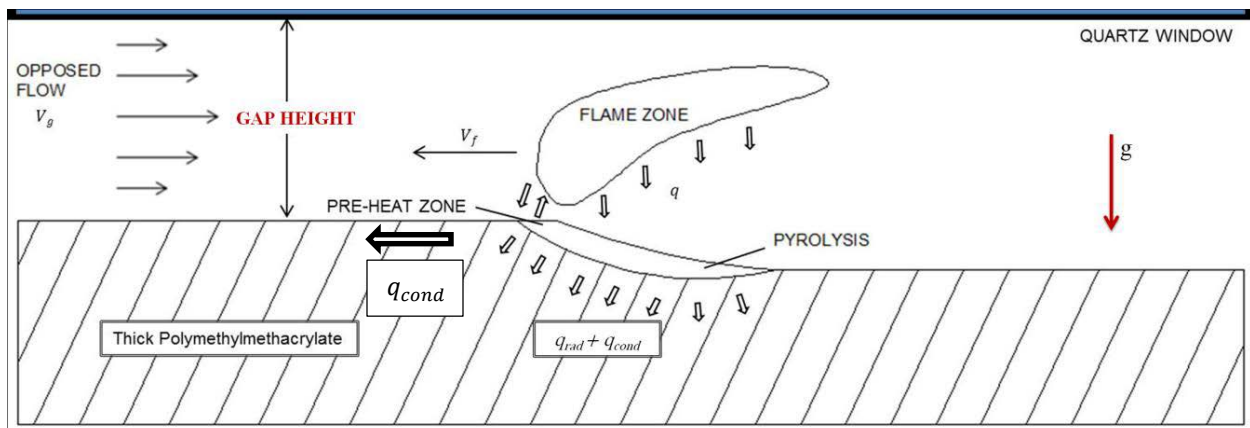

Figure 1: Schematic of thermally thick PMMA burning in the NCA [2]

¹ Previous tests were also conducted on the Space Shuttle, but that is no longer an option since the ending of that program.

This paper presents the results of forward heat conduction measurements from testing in the NCA using an Infrared (IR) camera. The camera was set up to measure the surface temperature of thermally thick PMMA considering the emissivity of the material and the transmission through the window of the NCA. Results from the IR camera were compared to a thermocouple embedded in the surface of the fuel.

2. Experimental Apparatus and Methods

The NCA consists of a horizontal 8.3 cm wide and 88 cm long channel. To limit the effects of buoyancy, the gap between the bottom of the channel and the quartz window in the lid of the channel is restricted to 5 mm. The channel is set up in an opposed flow configuration so that the direction of the flame propagation is opposite that of the flow. While the NCA can be run at varying oxygen concentrations and pressures, for these tests the conditions inside the channel matched atmospheric conditions with an oxygen concentration of 21% and a pressure of 101.3 kPa. The flow inside the channel is controlled by Alicat mass flow controllers and operated by a MATLAB GUI. In this test the opposed flow velocity was set to 15 cm/s. Ignition of the sample was done by passing 6 amps of current through 27 AWG Kanthal wire for approximately 30 seconds. The igniter wire was located near the downstream edge of the sample, approximately 1 mm above the surface, and spanned the full width of the sample.

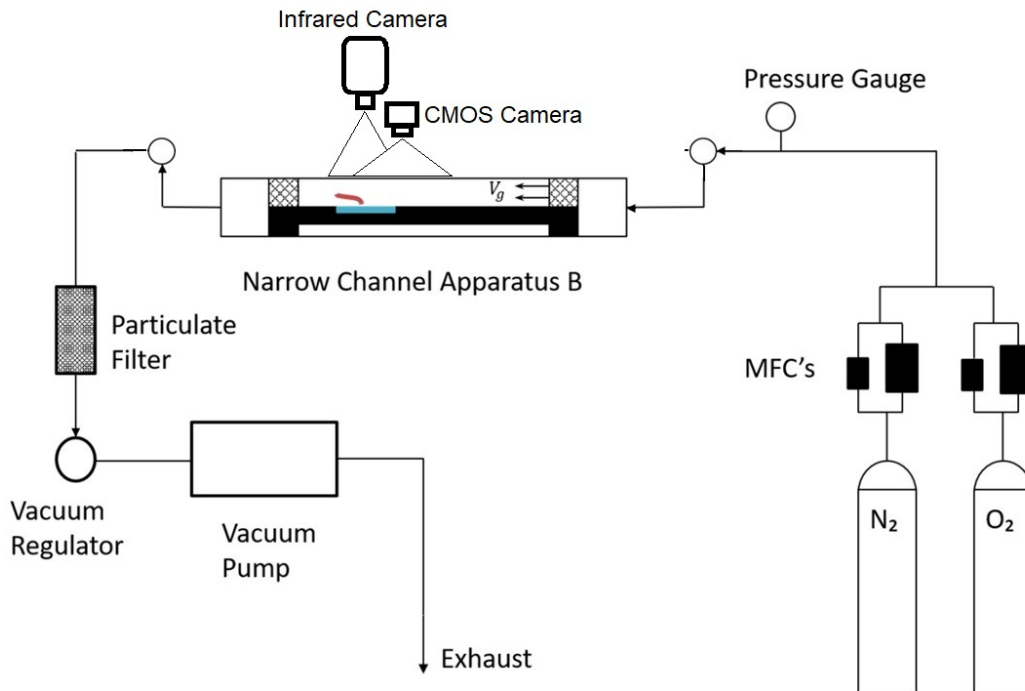

Figure 2: Schematic of the NCA experimental test setup [1]

The thickness of the PMMA used in testing was 3 mm. The samples are 5 cm wide and 12.5 cm long and top surface of the sample sits flush with the bottom of the channel during testing. Mica insulation is used on the sides and beneath the sample. The side mica insulation was 0.53 mm thick and bottom insulation 3.47 mm thick. A single type K thermocouple with a diameter of

Sub Topic: Fire

0.003” was embedded in the top surface of the sample with the wire spanning the fuel width and normal to the direction of flame spread. The thermocouple wire was embedded by passing an electric current through the thermocouple wire causing it to heat up and melt a tiny groove in the sample surface. During the test, thermocouple data were logged by a Daqpro 5300 at 1 Hz.

The IR camera used in this test was a FLIR SC6702. The camera’s spectral range is 1 to 5 microns. IR images were recorded using FLIR’s ResearchIR software. The camera was calibrated using a blackbody furnace (Oriol 67032) with the fused quartz window (10 mm thick) of the NCA placed in front to mimic emissions from the fuel through the window during an actual test. The quartz is low OH material (GE 124) that has a high transmission in the near IR region of the spectrum. Calibration measurements were taken in increments of 10 degrees Celsius, with ranges as shown in Table 1.

Initial tests used a 1 to 5 micron lens combined with a narrow bandpass filter centered at 3.4 microns (FWHM 130 nm). The wavelength of 3.4 microns represents a strong absorption/emission band for PMMA and relatively low emission band for other combustion byproducts [3]. This approach cut out temperatures lower than 150 C ahead of the flame due to insufficient signal. In order to capture the lower temperatures, the lens was switched to a 3 to 5 micron lens with no bandpass filter. Using this lens acts as a partial bandpass filter by cutting out emissions from 1 to 3 microns while letting in much more signal than the narrow bandpass filter.

For the 3 to 5 micron lens the camera was set up to use the Dynamic Range Extension (DRX) feature that allows the camera to capture a wide range of temperatures in a single image by combining multiple calibrations [4]. By using the DRX, the camera can pick up the forward conduction ahead of the flame as well as the peak temperatures at the flame front while not saturating the camera.

While effective at expanding the camera’s range, using the 3 to 5 micron lens with no bandpass filter had the side effect of having increasing signal contributions from the quartz window of the NCA, which heats up significantly during testing. To reduce this erroneous signal, an additional quartz disk (1/4” thick) was placed in front of the 3 to 5 micron lens during testing. This quartz disk was the same type of quartz used in the NCA and absorbed emissions from the hot window. Regardless of method applied, the lowest sample temperatures (between room temperature and ~ 50 C) are unable to be recorded due to signal loss from the window.

Table 1: Calibration temperature ranges used in the testing.

Test Method	Integration Time (ms)	Minimum Temperature (C)	Maximum Temperature (C)
Narrow Bandpass	2	150	430
DRX, no filter	2	40	150
DRX, no filter	0.5	100	250
DRX, no filter	0.04064	200	525
DRX with Quartz	2	60	150
DRX with Quartz	0.5	125	250
DRX with Quartz	0.04064	250	450

Sub Topic: Fire

An emissivity correction for temperatures recorded by the IR camera was implemented. By taking transmission data of PMMA of different thicknesses it is possible to numerically calculate the optical properties of PMMA, specifically n , the index of refraction, and k , the absorptive index [5,6]. These properties can be used to calculate a band emissivity for the spectral ranges of the lenses and bandpass filter. This band emissivity is applied to the camera calibrations to ensure accurate temperature readings.

These parameters were found using Eq. (1) through Eq. (4). Equation (1) represents transmission, T . By measuring T on a per wavelength basis for at least two sample thicknesses, d , the unknown parameters n and k can be solved for. Equation (2) for reflectivity, ρ , and Eq. (3) for internal transmissivity, τ , are plugged into Eq. (1). This yields two equations with three known values, the transmission T , sample thickness d , and wavelength λ , and two unknown values n , the index of refraction, and k , the absorptive index. Once n and k are solved for using Eq. (1) they be plugged back into Eq. (2) and Eq. (3) to find ρ and τ for any material thickness. Finally, with all optical parameters known, Eq. (4) for the emissivity, E , can then solved for and applied to a given waveband. For the 3 to 5 micron lens E was calculated to be 0.903.

$$T_{\lambda,d} = \frac{(1-\rho)^2\tau}{1-\rho^2\tau^2} \quad (1)$$

$$\rho = \frac{(n-1)^2+k^2}{(n+1)^2+k^2} \quad (2)$$

$$\tau = e^{-4\pi kd/\lambda} \quad (3)$$

$$E_{\lambda,d} = \frac{(1-\rho)(1-\tau)}{1-\rho\tau} \quad (4)$$

While the equations are extremely straightforward to solve with known n and k values, they are extremely difficult to solve if they are unknown. The equations cannot easily be solved analytically, and this necessitates a numerical solution. Finding detailed transmission data for PMMA in the IR spectrum was also difficult. It was necessary to take multiple sources of PMMA transmission data often recorded using different methods. This resulted in getting physically impossible values for n and k (negative values, imaginary numbers, etc.) before compatible data was found.

Finally, a CMOS digital camera (SV 5C10) was used to capture visible light images of the flame for flame spread tracking. Images were recorded using the Epix XCAP software and tracked using NASA's Spotlight image tracking software to obtain the flame spread rate [7].

3. Results and Discussion

IR temperature measurements are shown from three test methods in Figure 7, one with the 1 to 5 micron lens and narrow bandpass filter, one with the 3 to 5 micron lens and DRX enabled, and one with the 3 to 5 micron lens, DRX enabled, and quartz disk in front of the lens. The thermocouple data shown below is from the test with the narrow bandpass filter. Results from the IR images and thermocouple are plotted as temperature vs. distance to the flame front using

Sub Topic: Fire

flame spread rates obtained from tracking, as shown in Table 2. For the thermocouple this is a fixed location on the sample surface. The thermocouple junction was roughly in the center of the sample. For the IR this represents the temperature values of a single pixel during the test. For consistency across tests, the location of the pixel was chosen to match the approximate location of the thermocouple junction.

Table 2: Flame Spread Rates used to Calculate Distance to Flame Front

Test Method	Flame Spread Rate (microns/s)
Narrow Bandpass	65.9
3-5 micron lens with DRX, no filter	65.7
3-5 micron lens with DRX and Quartz	67.8

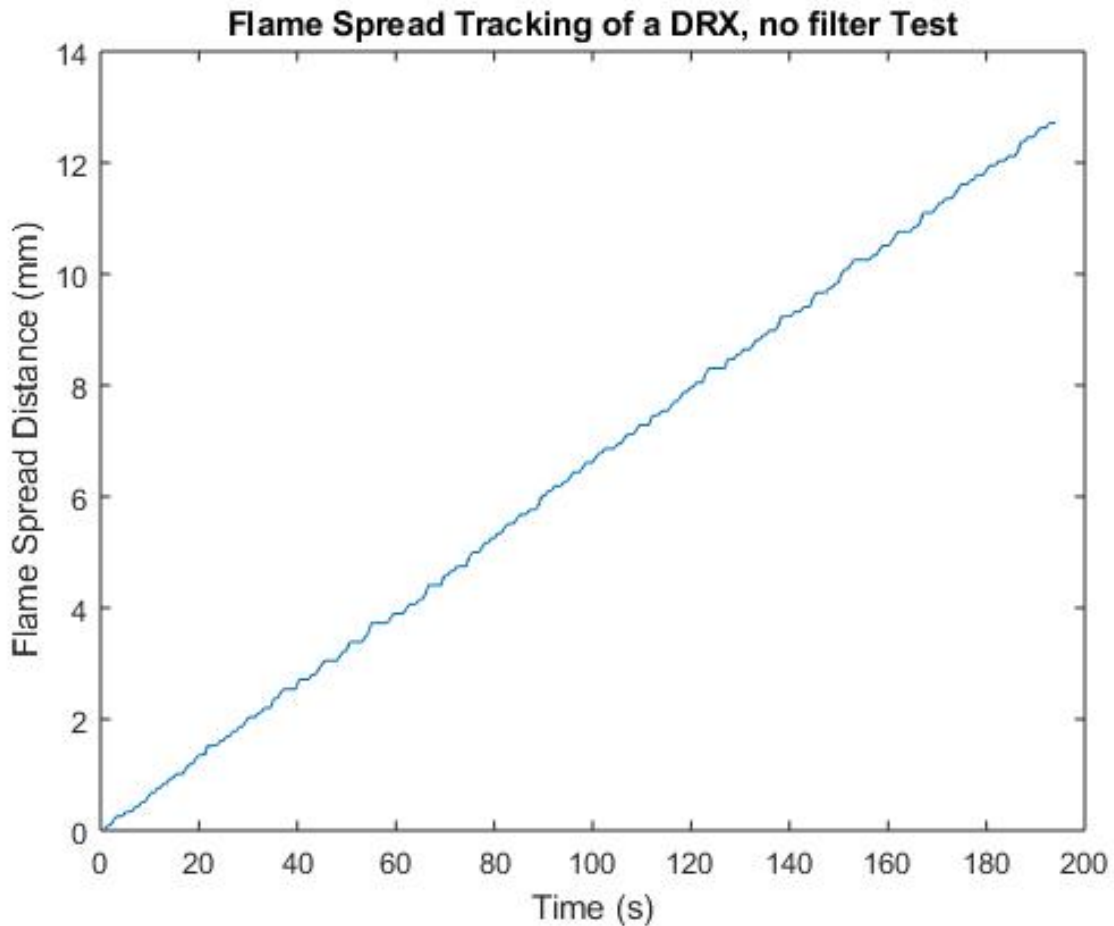

Figure 3: An example of flame position vs. time tracking from a test of 3-5 micron lens with the DRX, no filter

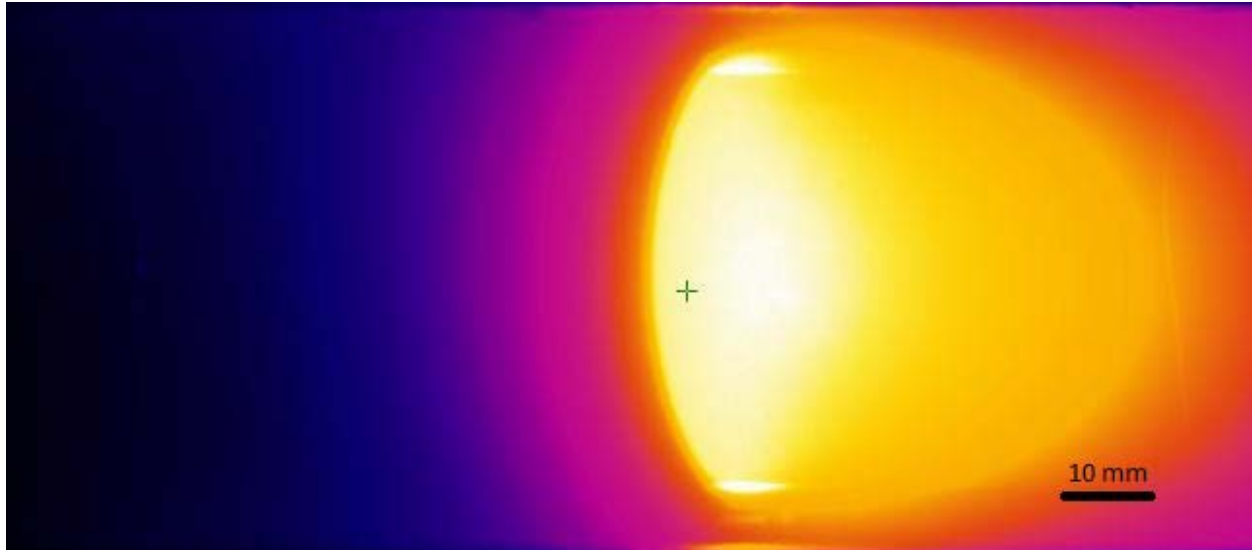

Figure 4: IR image of the PMMA sample during a test with the DRX enabled. The crosshair represents the location where temperature was determined

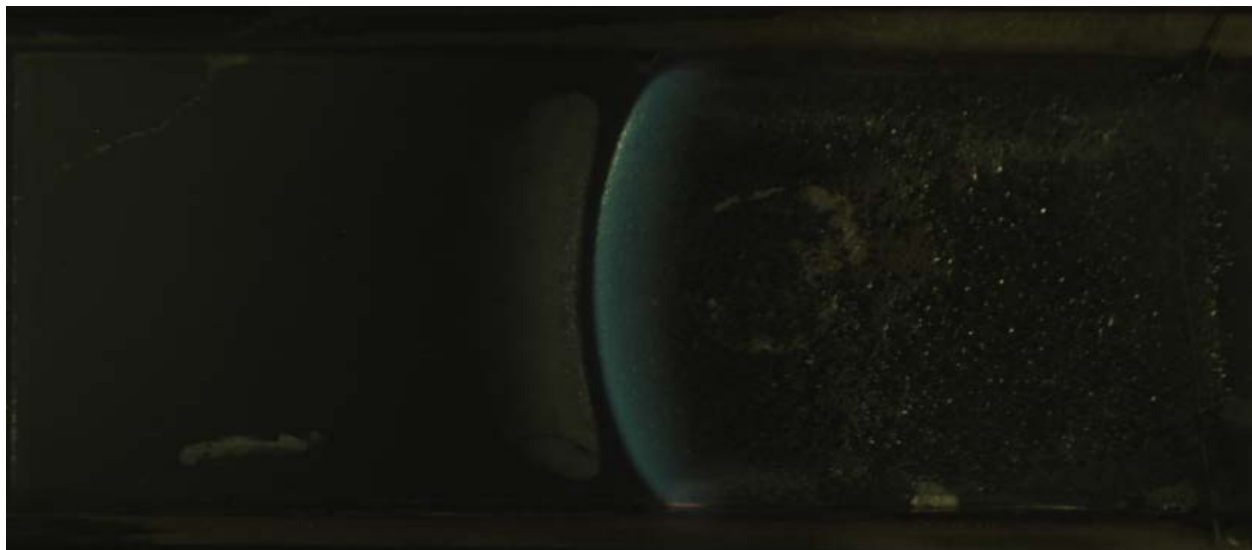

Figure 5: The equivalent visible light image of Figure 2

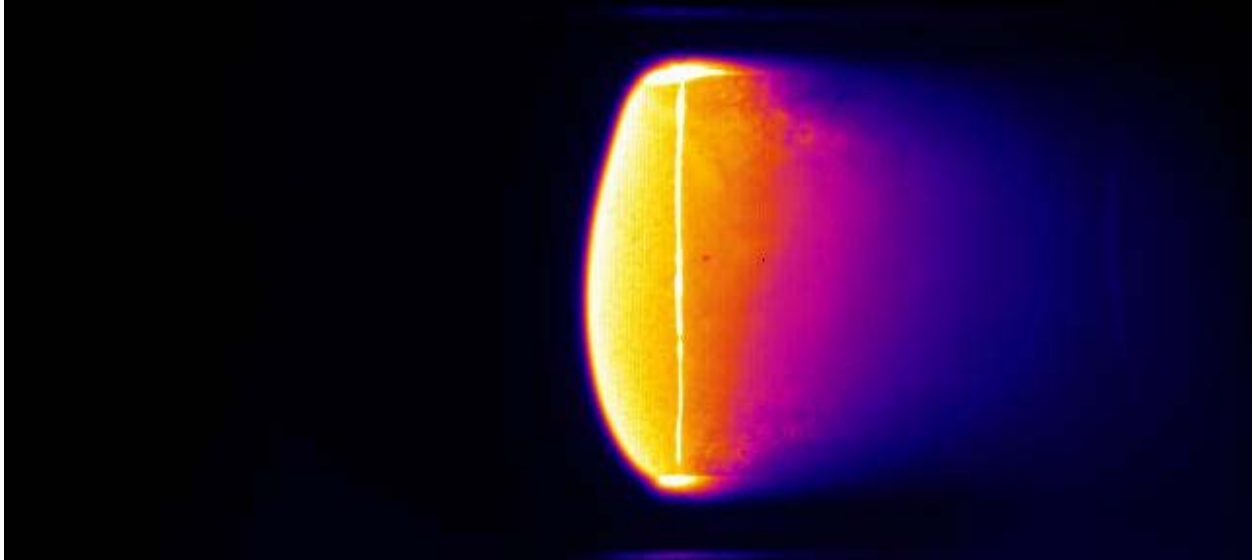

Figure 6: Location of the thermocouple embedded in the PMMA

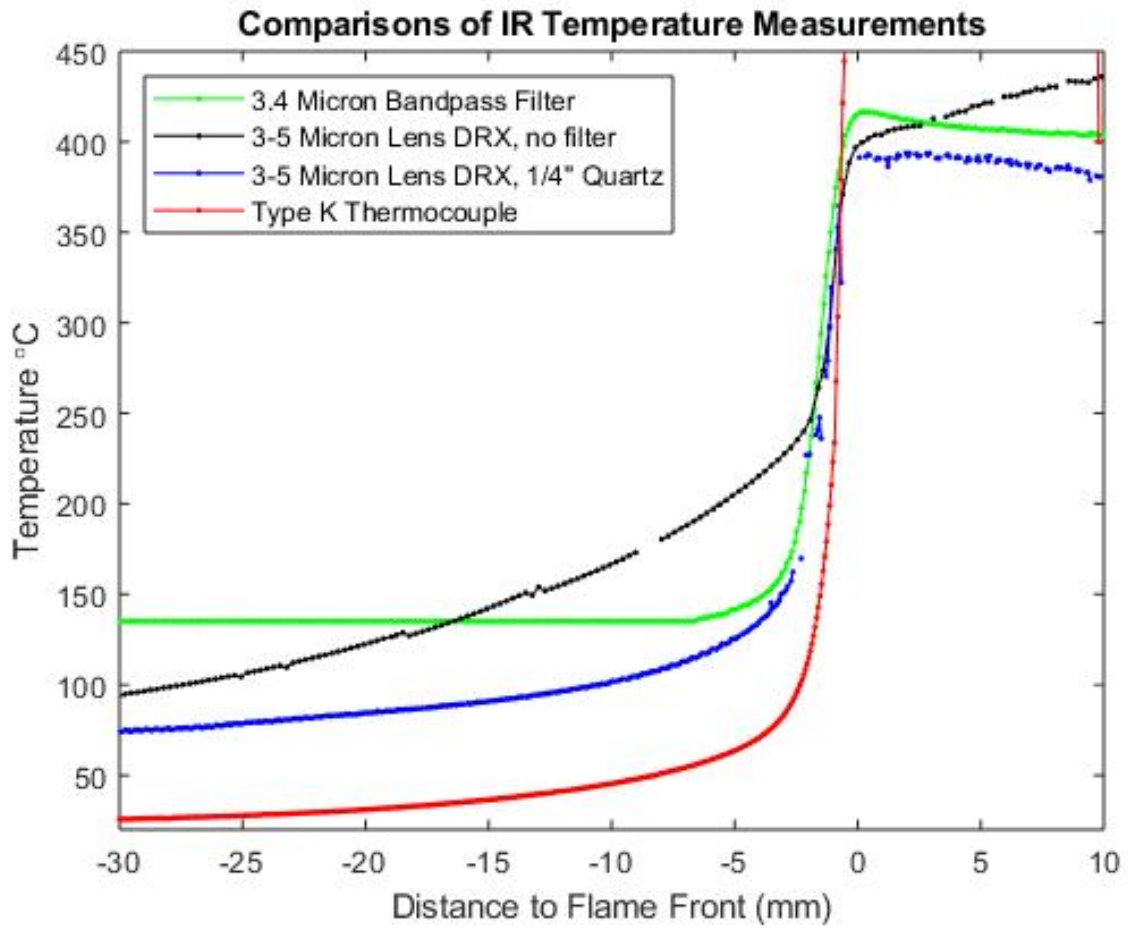

Figure 7: Comparisons of temperature measurement methods as the flame front approaches a specific location

Sub Topic: Fire

Results from all methods of IR calibration and the thermocouple show significant heating of the sample surface well ahead of the flame front. While results from the bandpass filter are limited by the minimum calibration temperature of 150 C, there is still a noticeable preheating region approximately 5 mm ahead of the flame front. Using the DRX with no filter captured lower temperatures than using the narrow bandpass filter. However, the preheating temperatures ahead of the flame front and peak temperatures behind the flame front differ significantly from the other test methods and thermocouple results. This suggests that emissions from the window tainted the temperature readings. Finally, using the DRX with the quartz disk allowed for the same lower temperatures as to be recorded. The preheating temperature trends are similar to the thermocouple, while the peak temperatures trends are similar to the results obtained with the narrow bandpass filter.

Results from the thermocouple likely represent the true sample surface temperature for much of the preheating region. However, the temperature recorded at the flame front by the thermocouple is 1095 C and is off scale in Figure 4. This is because as the flame front reaches the thermocouple, the sample material surrounding the thermocouple is removed. This leads to the thermocouple effectively reading a gas phase temperature.

Results from the narrow bandpass filter, DRX with quartz disk, and the thermocouple all show similar results in the region approximately 2 mm ahead of the flame front where the temperature gradient is steepest. Each method is bound by physical limitations of the test setup, emissions and signal loss from the quartz window of the NCA for the IR measurements, and reading of gas phase temperatures for the thermocouple. However, when taken together they give a much more complete picture of forward conduction in the sample.

4. Conclusions

Data collected from the IR camera and thermocouples shows that significant forward heat conduction ahead of the flame front occurs on the surface during the tests. This was estimated using Fourier's Law and a peak of 1.9 kW/m^2 was found in the region 1 mm ahead of the flame. Addition of the quartz disk to the 3-5 micron lens with the DRX enabled significantly improved results in the preheating region. In progress work of cooling the quartz window of the NCA to further reduce emissions may bring the IR camera and thermocouple results further inline. Differences between the IR camera and thermocouple in the flame region can be attributed to the thermocouple reading the gas phase temperature.

Ultimately, the measurements of forward heat conduction demonstrate the need to model all further tests of PMMA in the NCA as a two-dimensional problem. Conclusions cannot be drawn from the one-dimensional problem due to significant heating of the fuel ahead of the flame that is not considered when only the conduction normal to the surface is considered. Measurements of forward heat conduction can also be used as a benchmark to compare against and help refine the computational model.

5. Acknowledgements

This research and fabrication of the NCA was funded by NASA under the grant NNX10AD96A. Thanks are due to the following former Combustion and Solar Energy Laboratory members. Nick Lage, for his work on the NCA project in computational modeling of PMMA and development of embedded thermocouple testing procedures. Kelsey Winter, for her work on the NCA project and guidance throughout.

6. References

- [1] N. Lage, Two Dimensional Heat Transfer in Non-Thermally Thin Poly(Methyl Methacrylate) During Combustion in a Narrow Channel Apparatus, San Diego State University, 2018.
- [2] G. Randall Bornand, Polymethylmethacrylate combustion in a narrow channel apparatus simulating a microgravity environment, San Diego State University, 2014.
- [3] P. Beauchamp, Infrared Tables (short summary of common absorption frequencies) organic compounds, Spectrosc. Tables. 2620 (n.d.) 1–15.
http://www.cpp.edu/~psbeauchamp/pdf/spec_ir_nmr_spectra_tables.pdf.
- [4] FLIR, ResearchIR 4, 2016. file:///E:/ResearchIR Manual.pdf.
- [5] J.R. Hallman, Ignition characteristics of plastics and rubber, University of Oklahoma., 1971.
- [6] G. Beadie, M. Brindza, R.A. Flynn, A. Rosenberg, J.S. Shirk, Refractive index measurements of poly(methyl methacrylate) (PMMA) from 04–16 μm , Appl. Opt. 54 (2015) F139. doi:10.1364/ao.54.00f139.
- [7] R. Klimek, T. Wright, Spotlight – 8 Image Analysis Software, Glenn Research Center, NASA, 2006.